

HCPL-540X*, 5962-89570, HCPL-543X, HCPL-643X, 5962-89571

Hermetically Sealed, Very High Speed,
Logic Gate Optocouplers



Data Sheet

*See matrix for available extensions.

Description

These units are single and dual channel, hermetically sealed optocouplers. The products are capable of operation and storage over the full military temperature range and can be purchased as either standard product or with full MIL-PRF-38534 Class Level H or K testing or from the appropriate DLA Drawing. All devices are manufactured and tested on a MIL-PRF-38534 certified line and are included in the DLA Qualified Manufacturers List, QML-38534 for Hybrid Microcircuits.

Functional Diagram

Multiple channel devices available

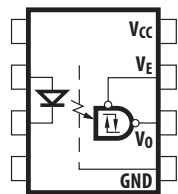

Truth Tables (Positive Logic)

Multichannel Devices

Input	Output
On (H)	L
Off (L)	H

Single Channel DIP

Input	Enable	Output
On (H)	L	L
Off (L)	L	H
On (H)	H	Z
Off (L)	H	Z

The connection of a 0.1 μ F bypass capacitor between V_{CC} and GND is recommended.

Features

- Dual marked with device part number and DLA standard microcircuit drawing
- Manufactured and tested on a MIL-PRF-38534 certified line
- QML-38534, Class H and K
- Three hermetically sealed package configurations
- Performance guaranteed over full military temperature range: -55°C to $+125^{\circ}\text{C}$
- High Speed: 40 M bit/s
- High common mode rejection 500 V/ μ s guaranteed
- 1500 Vdc withstand test voltage
- Active (totem pole) outputs
- Three stage output available
- High radiation immunity
- HCPL-2400/30 function compatibility
- Reliability data
- Compatible with TTL, STTL, LSTTL, and HCMOS logic families

Applications

- Military and space
- High reliability systems
- Transportation, medical, and life critical systems
- Isolation of high speed logic systems
- Computer-peripheral interfaces
- Switching power supplies
- Isolated bus driver (networking applications) – (5400/1/K only)
- Pulse transformer replacement
- Ground loop elimination
- Harsh industrial environments
- High speed disk drive I/O
- Digital isolation for A/D, D/A conversion

CAUTION: It is advised that normal static precautions be taken in handling and assembly of this component to prevent damage and/or degradation which may be induced by ESD.

Each channel contains an AlGaAs light emitting diode which is optically coupled to an integrated high gain photon detector. This combination results in very high data rate capability. The detector has a threshold with hysteresis, which typically provides 0.25 mA of differential mode noise immunity and minimizes the potential for output signal chatter. The detector in the single channel units has a three state output stage which eliminates the need for a pull-up resistor and allows for direct drive of a data bus.

All units are compatible with TTL, STTL, LSTTL, and HCMOS logic families. The 35 ns pulse width distortion specification guarantees a 10 MBd signaling rate at +125° C with 35% pulse width distortion. Figures 13 through 16 show recommended circuits for reducing pulse width distortion and optimizing the signal rate of the product. Package styles for these parts are 8 pin DIP through hole

(case outlines P), and leadless ceramic chip carrier (case outline 2). Devices may be purchased with a variety of lead bend and plating options. See Selection Guide Table for details. Standard Microcircuit Drawing (SMD) parts are available for each package and lead style.

Because the same electrical die (emitters and detectors) are used for each channel of each device listed in this data sheet, absolute maximum ratings, recommended operating conditions, electrical specifications, and performance characteristics shown in the figures are similar for all parts. Occasional exceptions exist due to package variations and limitations and are as noted. Additionally, the same package assembly processes and materials are used in all devices. These similarities give justification for the use of data obtained from one part to represent other part's performance for die related reliability and certain limited radiation test results.

Selection Guide—Package Styles and Lead Configuration Options

Package	8 Pin DIP	8 Pin DIP	20 Pad LCCC
Lead Style	Through Hole	Through Hole	Surface Mount
Channels	1	2	2
Common Channel Wiring	None	V _{CC} , GND	None
Avago Part # & Options			
Commercial	HCPL-5400	HCPL-5430	HCPL-6430
MIL-PRF-38534, Class H	HCPL-5401	HCPL-5431	HCPL-6431
MIL-PRF-38534, Class K	HCPL-540K	HCPL-543K	HCPL-643K
Standard Lead Finish	Gold Plate	Gold Plate	Solder Pads*
Solder Dipped*	Option 200	Option 200	
Butt Cut/Gold Plate	Option 100	Option 100	
Gull Wing/Soldered*	Option 300	Option 300	
Class H SMD Part #			
<i>Prescript for all below</i>	5962-	5962-	5962-
Gold Plate	8957001PC	8957101PC	
Solder Dipped*	8957001PA	8957101PA	89571022A
Butt Cut/Gold Plate	8957001YC	8957101YC	
Butt Cut/Soldered*	8957001YA	8957101YA	
Gull Wing/Soldered*	8957001XA	8957101XA	
Class K SMD Part #			
<i>Prescript for all below</i>	5962-	5962-	5962-
Gold Plate	8957002KPC	8957103KPC	
Solder Dipped*	8957002KPA	8957103KPA	8957104K2A
Butt Cut/Gold Plate	8957002KYC	8957103KYC	
Butt Cut/Soldered*	8957002KYA	8957103KYA	
Gull Wing/Soldered*	8957002KXA	8957103KXA	

*Solder contains lead.

Functional Diagrams

8 Pin DIP	8 Pin DIP	20 Pad LCCC
Through Hole	Through Hole	Surface Mount
1 Channel	2 Channels	2 Channels

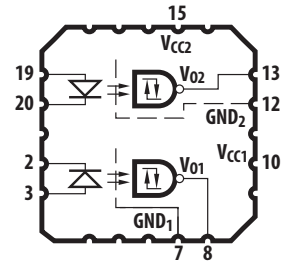
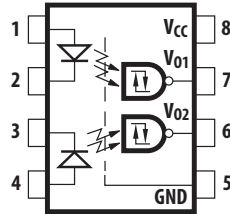
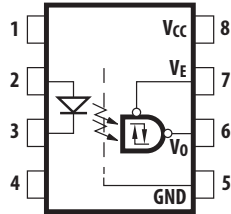

Note:

All DIP devices have common V_{CC} and ground. LCCC (leadless ceramic chip carrier) package has isolated channels with separate V_{CC} and ground connections.

Outline Drawings

20 Terminal LCCC Surface Mount, 2 Channels

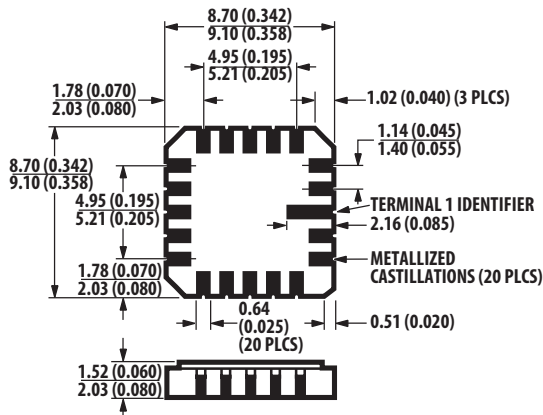

Note: Dimensions in millimeters (inches).
Solder thickness 0.127 (0.005) max.

8 Pin DIP Through Hole, 1 and 2 Channel

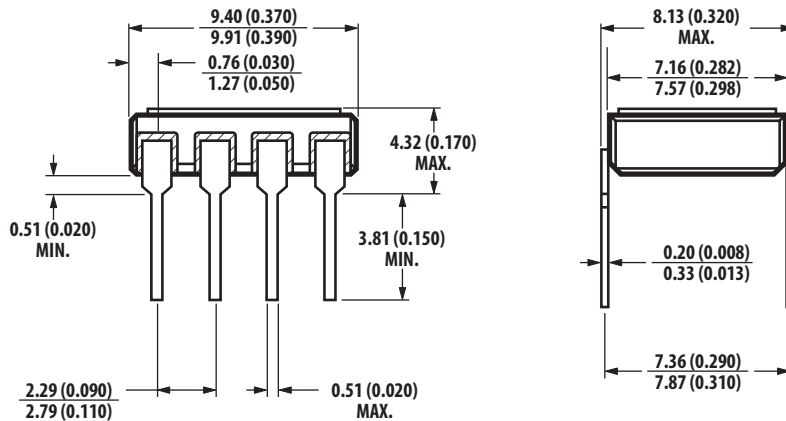

Note: Dimensions in millimeters (inches).

Leaded Device Marking

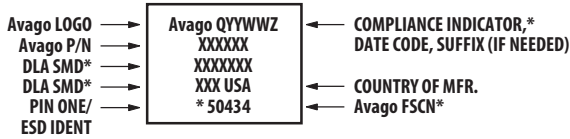

* QUALIFIED PARTS ONLY

Leadless Device Marking

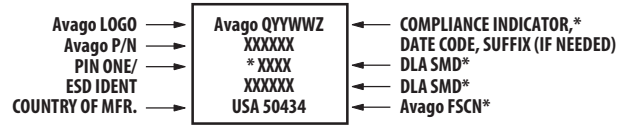

* QUALIFIED PARTS ONLY

Hermetic Optocoupler Options

Option	Description
100	Surface mountable hermetic optocoupler with leads trimmed for butt joint assembly. This option is available on commercial and hi-rel product in 8 pin DIP (see drawings below for details).
<p>Note: Dimensions in millimeters (inches).</p>	
200	Lead finish is solder dipped rather than gold plated. This option is available on commercial and hi-rel product in 8 pin DIP. DLA Drawing part numbers contain provisions for leadfinish. All leadless chip carrier devices are delivered with solder dipped terminals as a standard feature.
300	Surface mountable hermetic optocoupler with leads cut and bent for gull wing assembly. This option is available on commercial and hi-rel product in 8 pin DIP (see drawings below for details). This option has solder dipped leads.
<p>Note: Dimensions in millimeters (inches).</p>	

*Solder contains lead.

Absolute Maximum Ratings

No derating required up to +125° C.

Parameter	Symbol	Min.	Max.	Units	Note
Storage Temperature	T_S	-65	+150	°C	
Operating Temperature	T_A	-55	+125	°C	
Case Temperature	T_C		+170	°C	
Junction Temperature	T_J		+175	°C	
Lead Solder Temperature			260 for 10 sec	°C	
Average Forward Current (each channel)	$I_{F(AVG)}$		10	mA	
Peak Input Current (each channel)	$I_{F(PEAK)}$		20	mA	1
Reverse Input Voltage (each channel)	V_R		3	V	
Supply Voltage	V_{CC}	0.0	7.0	V	
Average Output Current (each channel)	$I_{O(AVG)}$	-25	25	mA	
Output Voltage (each channel)	V_O	-0.5	10	V	
Output Power Dissipation (each channel)	P_O		130	mW	
Package Power Dissipation (each channel)	P_D		200	mW	

Single Channel Product Only

Three State Enable Voltage	V_E	-0.5	10	V	
----------------------------	-------	------	----	---	--

8 Pin Ceramic DIP Single Channel Schematic

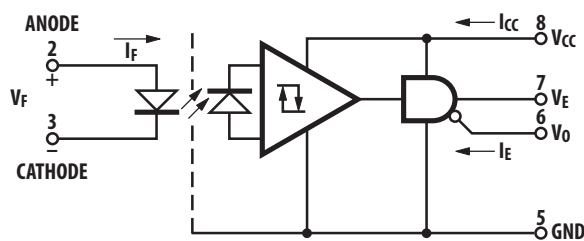

Note: Enable pin 7. An external 0.01 μ F to 0.1 μ F bypass capacitor must be connected between V_{CC} and ground for each package type.

ESD Classification

(MIL-STD-883, Method 3015)

HCPL-5400/01/0K	(\blacktriangle), Class 2
HCPL-5430/31/3K and HCPL-6430/31/3K	(Dot), Class 3

Recommended Operating Conditions

Parameter	Symbol	Min.	Max.	Units
Input Current (High)	$I_{F(ON)}$	6	10	mA
Supply Voltage, Output	V_{CC}	4.75	5.25	V
Input Voltage (Low)	$V_{F(OFF)}$	-	0.7	V
Fan Out (Each Channel)	N	-	5	TTL Loads

Single Channel Product Only

High Level Enable Voltage	V_{EH}	2.0	V_{CC}	V
Low Level Enable Voltage	V_{EL}	0	0.8	V

Electrical Characteristics

$T_A = -55^\circ\text{C}$ to $+125^\circ\text{C}$, $4.75\text{ V} \leq V_{CC} \leq 5.25\text{ V}$, $6\text{ mA} \leq I_{F(\text{ON})} \leq 10\text{ mA}$, $0\text{ V} \leq V_{F(\text{OFF})} \leq 0.7\text{ V}$, unless otherwise specified.

Parameter	Sym.	Test Conditions	Subgroups	Group A ¹⁰		Limits		Fig.	Notes
				Min.	Typ.*	Max.	Units		
Low Level Output Voltage	V_{OL}	$I_{OL} = 8.0\text{ mA}$ (5 TTL Loads)	1, 2, 3		0.3	0.5	V	1	9
High Level Output Voltage	V_{OH}	$I_{OH} = -4.0\text{ mA}$	1, 2, 3	2.4			V	2	9
Output Leakage Current	I_{OHH}	$V_O = 5.25\text{ V}$, $V_F = 0.7\text{ V}$	1, 2, 3			100	μA		9
Logic High Supply Current	Single Channel	$V_{CC} = 5.25\text{ V}$, $V_E = 0\text{ V}$	1, 2, 3		17	26	mA		
	Dual Channel				34	52			
Logic Low Supply Current	Single Channel	$V_{CC} = 5.25\text{ V}$, $V_E = 0\text{ V}$	1, 2, 3		19	26	mA		
	Dual Channel				38	52			
Input Forward Voltage	V_F	$I_F = 10\text{ mA}$	1, 2, 3	1.0	1.35	1.85	V	4	9
Input Reverse Breakdown Voltage	V_R	$I_R = 10\ \mu\text{A}$	1, 2, 3	3.0	4.8		V		9
Input-Output Insulation Leakage Current	I_{I-O}	$V_{I-O} = 1500\text{ Vdc}$, $RH \leq 65\%$, $t = 5\text{ s}$	1			1.0	μA		2, 3
Propagation Delay Time Logic Low Output	t_{PHL}		9, 10, 11		33	60	ns	5, 6, 7	4, 9
Propagation Delay Time Logic High Output	t_{PLH}		9, 10, 11		30	60	ns	5, 6, 7	4, 9
Pulse Width Distortion	PWD		9, 10, 11		3	35	ns	5, 6, 7	4, 9
Logic High Common Mode Transient Immunity	$ CM_H $	$V_{CM} = 50\text{ V}_{P-P}$, $I_F = 0\text{ mA}$	9, 10, 11	500	3000		$\text{V}/\mu\text{s}$	11	5, 9, 11
Logic Low Common Mode Transient Immunity	$ CM_L $	$V_{CM} = 50\text{ V}_{P-P}$, $I_F = 6\text{ mA}$	9, 10, 11	500	3000		$\text{V}/\mu\text{s}$	11	5, 9, 11

Single Channel Product Only

Parameter	Sym.	Test Conditions	Subgroups	Group A10		Limits		Fig.	Notes
				Min.	Typ.*	Max.	Units		
Logic High Enable Voltage	V_{EH}		1, 2, 3	2.0			V		
Logic Low Enable Voltage	V_{EL}		1, 2, 3			0.8	V		
Logic High Enable Current	I_{EH}	$V_E = 2.4\text{ V}$	1, 2, 3			20	μA		
		$V_E = 5.25\text{ V}$	1, 2, 3			100			
Logic Low Enable Current	I_{EL}	$V_E = 0.4\text{ V}$	1, 2, 3		-0.28	-0.4	mA		
High Impedance State Supply Current	I_{CCZ}	$V_{CC} = 5.25\text{ V}$, $V_E = 5.25\text{ V}$	1, 2, 3		22	28	mA		
High Impedance State Output Current	I_{OZH}	$V_O = 0.4\text{ V}, V_E = 2\text{ V}$	1, 2, 3			-20	μA		
		$V_O = 2.4\text{ V}, V_E = 2\text{ V}$			20				
		$V_O = 5.25\text{ V}, V_E = 2\text{ V}$			100				

*All typical values are at $V_{CC} = 5\text{ V}$, $T_A = 25^\circ\text{C}$, $I_F = 8\text{ mA}$ except where noted.

Typical Characteristics

All typical values are at $T_A = 25^\circ\text{C}$, $V_{CC} = 5\text{ V}$, $I_F = 8\text{ mA}$, unless otherwise specified.

Parameter	Symbol	Typ.	Units	Test Conditions	Fig.	Notes
Input Current Hysteresis	I_{HYS}	0.25	mA	$V_{CC} = 5\text{ V}$	3	
Input Diode Temperature Coefficient	$\frac{\Delta V_F}{\Delta T_A}$	-1.11	mV/ $^\circ\text{C}$	$I_F = 10\text{ mA}$	4	
Resistance (Input-Output)	R_{I-O}	10^{12}	Ω	$V_{I-O} = 500\text{ V}$		2
Capacitance (Input-Output)	C_{I-O}	0.6	pF	$f = 1\text{ MHz}$, $V_{I-O} = 0\text{ V}$		2
Logic Low Short Circuit Output Current	I_{OSL}	65	mA	$V_O = V_{CC} = 5.25\text{ V}$, $I_F = 10\text{ mA}$		6, 9
Logic High Short Circuit Output Current	I_{OSH}	-50	mA	$V_{CC} = 5.25\text{ V}$, $I_F = 0\text{ mA}$, $V_O = \text{GND}$		6, 9
Output Rise Time (10-90%)	t_r	15	ns		5	
Output Fall Time (90-10%)	t_f	10	ns		5	
Propagation Delay Skew	t_{PSK}	30	ns		10	12
Power Supply Noise Immunity	PSNI	0.5	V_{P-P}	$48\text{ Hz} \leq f_{ac} \leq 50\text{ MHz}$		7

Single Channel Product Only

Parameter	Symbol	Typ.	Units	Test Conditions	Fig.	Notes
Input Capacitance	C_{IN}	15	pF	$f = 1\text{ MHz}$, $V_F = 0\text{ V}$, Pins 2 and 3		
Output Enable Time to Logic High	t_{PZH}	15	ns		8, 9	
Output Enable Time to Logic Low	t_{PZL}	30	ns		8, 9	
Output Disable Time from Logic High	t_{PHZ}	20	ns		8, 9	
Output Disable Time from Logic Low	t_{PLZ}	15	ns		8, 9	

Dual and Quad Channel Product Only

Input Capacitance	C_{IN}	15	pF	$f = 1\text{ MHz}$, $V_O = 0\text{ V}$		
Input-Input Leakage Current	I_{I-I}	0.5	nA	$RH \leq 65\%$, $V_{I-I} = 500\text{ Vdc}$		8
Input-Input Resistance	R_{I-I}	10^{12}	Ω	$V_{I-I} = 500\text{ V}$		8
Input-Input Capacitance	C_{I-I}	1.3	pF	$f = 1\text{ MHz}$, $V_F = 0\text{ V}$		8

Notes:

- Not to exceed 5% duty factor, not to exceed 50 μsec pulse width.
- All devices are considered two-terminal devices: measured between all input leads or terminals shorted together and all output leads or terminals shorted together.
- This is a momentary withstand test, not an operating condition.
- t_{PHL} propagation delay is measured from the 50% point on the rising edge of the input current pulse to the 1.5 V point on the falling edge of the output pulse. The t_{PLH} propagation delay is measured from the 50% point on the falling edge of the input current pulse to the 1.5 V point on the rising edge of the output pulse. Pulse Width Distortion, $PWD = |t_{PHL} - t_{PLH}|$.
- CM_L is the maximum slew rate of the common mode voltage that can be sustained with the output voltage in the logic low state ($V_{O(MAX)} < 0.8\text{ V}$). CM_H is the maximum slew rate of the common mode voltage that can be sustained with the output voltage in the logic high state ($V_{O(MIN)} > 2.0\text{ V}$).
- Duration of output short circuit time not to exceed 10 ms.
- Power Supply Noise Immunity is the peak to peak amplitude of the ac ripple voltage on the V_{CC} line that the device will withstand and still remain in the desired logic state. For desired logic high state, $V_{OH(MIN)} > 2.0\text{ V}$, and for desired logic low state, $V_{OL(MAX)} < 0.8\text{ V}$.
- Measured between adjacent input pairs shorted together for each multichannel device.
- Each channel.
- Standard parts receive 100% testing at 25° C (Subgroups 1 and 9). SMD, Class H and Class K parts receive 100% testing at 25° C , 125° C , and -55° C (Subgroups 1 and 9, 2 and 10, 3 and 11, respectively).
- Parameters are tested as part of device initial characterization and after design and process changes. Parameters are guaranteed to limits specified for all lots not specifically tested.
- Propagation delay skew is defined as the difference between the minimum and maximum propagation delays for any given group of optocouplers with the same part number that are all switching at the same time under the same operating conditions.
- The HCPL-6430, HCPL-6431, and HCPL-643K dual channel parts function as two independent single channel units. Use the single channel parameter limits.

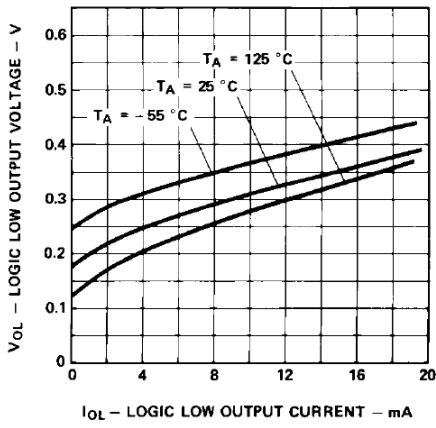

Figure 1. Typical logic low output voltage vs. logic low output current

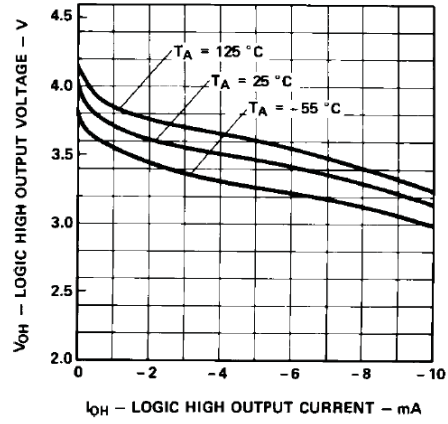

Figure 2. Typical logic high output voltage vs. logic high output current

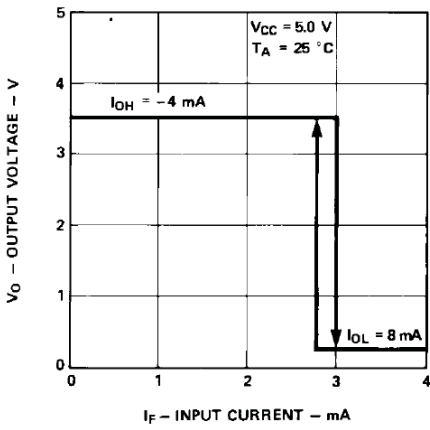

Figure 3. Typical output voltage vs. input forward current

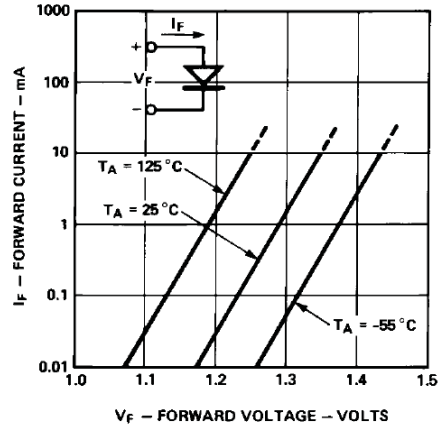

Figure 4. Typical diode input forward current characteristic

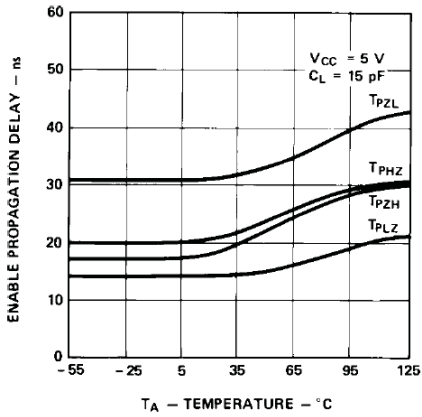

Figure 9. Typical enable propagation delay vs. ambient temperature. (single channel product only)

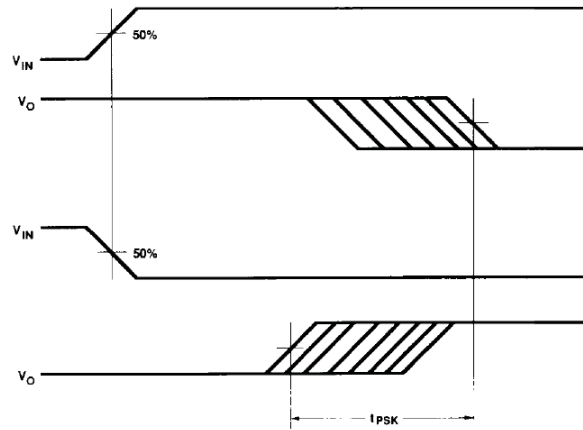
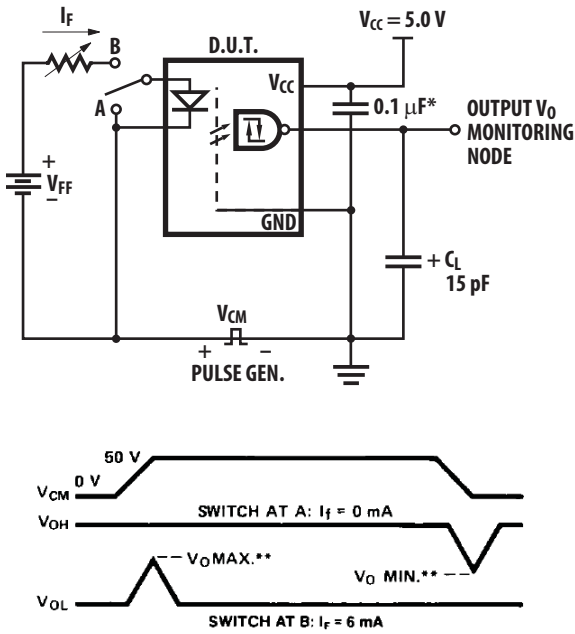
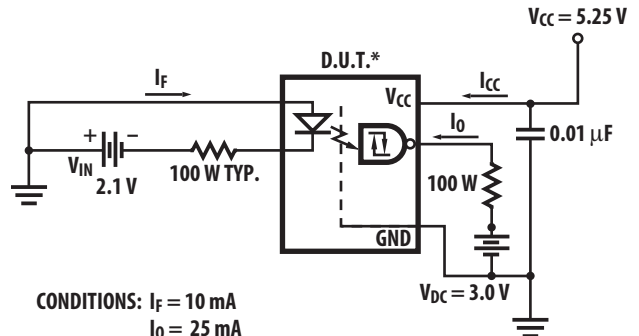

Figure 10. Propagation delay skew, t_{PSK} , waveform



*TOTAL LEAD LENGTH < 10 mm FROM DEVICE UNDER TEST.
 **SEE NOTE 5.
 † C_L IS APPROXIMATELY 15 pF, WHICH INCLUDES PROBE AND STRAY WIRING CAPACITANCE.

Figure 11. Test diagram for common mode transient immunity and typical waveforms



CONDITIONS: $I_f = 10 \text{ mA}$
 $I_o = 25 \text{ mA}$

$T_A = +125 \text{ }^\circ\text{C}$

* FOR SINGLE CHANNEL UNITS,
 GROUND ENABLE PIN.

Figure 12. Operating circuit for burn-in and steady state life tests

MIL-PRF-38534 Class H, Class K, and DLA SMD Test Program

Avago Technologies' Hi-Rel Optocouplers are in compliance with MIL-PRF-38534 Classes H and K. Class H and Class K devices are also in compliance with DLA drawings 5962-89570, and 5962-89571.

Testing consists of 100% screening and quality conformance inspection to MIL-PRF-38534.

Data Rate and Pulse-Width Distortion Definitions

Propagation delay is a figure of merit which describes the finite amount of time required for a system to translate information from input to output when shifting logic levels. Propagation delay from low to high (t_{PLH}) specifies the amount of time required for a system's output to change from a Logic 0 to a Logic 1, when given a stimulus at the input. Propagation delay from high to low (t_{PHL}) specifies

the amount of time required for a system's output to change from a Logic 1 to a Logic 0, when given a stimulus at the input (see Figure 5).

When t_{PLH} and t_{PHL} differ in value, pulse width distortion results. Pulse width distortion is defined as $|t_{PHL} - t_{PLH}|$ and determines the maximum data rate capability of a distortion-limited system. Maximum pulse width distortion on the order of 25-35% is typically used when specifying the maximum data rate capabilities of systems. The exact figure depends on the particular application (RS-232, PCM, T-1, etc.).

These high performance optocouplers offer the advantages of specified propagation delay (t_{PLH} , t_{PHL}), and pulse width distortion ($|t_{PLH} - t_{PHL}|$) over temperature and power supply voltage ranges.

Applications

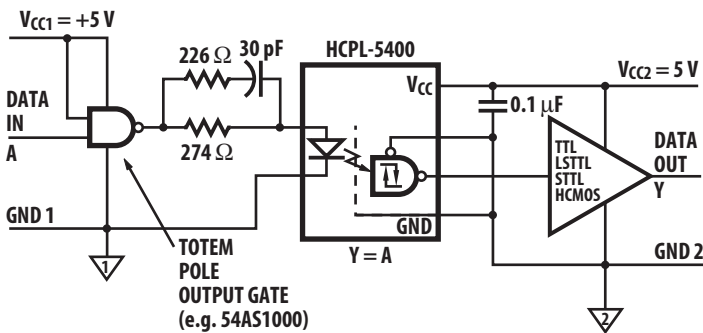

Figure 13. Recommended HCPL-5400 interface circuit

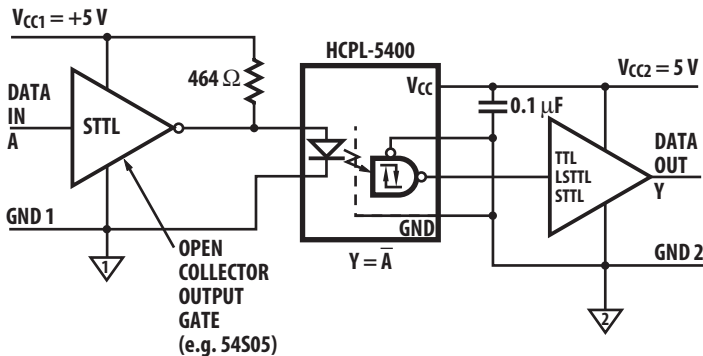

Figure 14. Alternative HCPL-5400 interface circuit

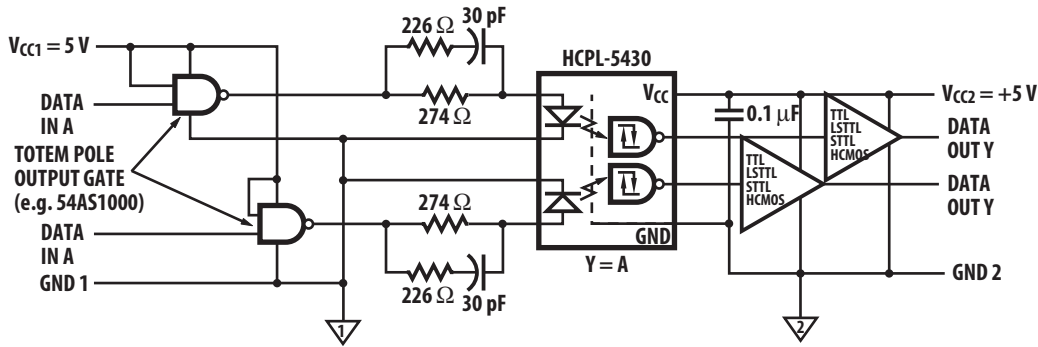

Figure 15. Recommended HCPL-5430 and HCPL-6430 interface circuit

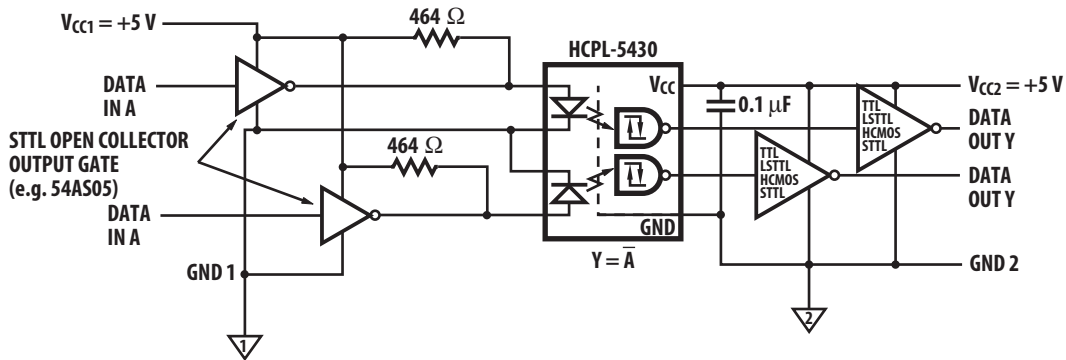

Figure 16. Alternative HCPL-5430 and HCPL-6430 interface circuit

For product information and a complete list of distributors, please go to our web site: www.avagotech.com

Avago, Avago Technologies, and the A logo are trademarks of Avago Technologies in the United States and other countries. Data subject to change. Copyright © 2005-2012 Avago Technologies. All rights reserved. Obsoletes 5968-9403E AV02-3838EN - October 2, 2012

