

HCPL-0720, HCPL-7720, HCPL-0721, and HCPL-7721

40-ns Propagation Delay, CMOS Optocoupler

Description

Available in either an 8-pin DIP or SO-8 package style respectively, the Broadcom[®] HCPL-772X or HCPL-072X optocouplers utilize the latest CMOS IC technology to achieve outstanding performance with very low power consumption. The HCPL-772X/072X require only two bypass capacitors for complete CMOS compatibility.

Basic building blocks of the HCPL-772X/072X are a CMOS LED driver IC, a high-speed LED, and a CMOS detector IC. A CMOS logic input signal controls the LED driver IC, which supplies current to the LED. The detector IC incorporates an integrated photodiode, a high-speed transimpedance amplifier, and a voltage comparator with an output driver.

CAUTION! It is advised that normal static precautions be taken in handling and assembly of this component to prevent damage and/or degradation which may be induced by ESD. The components featured in this data sheet are not to be used in military or aerospace applications or environments.

Features

- +5V CMOS compatibility
- 20-ns max propagation delay skew
- High speed: 25 MBd
- 40-ns max propagation delay
- 10-kV/ μ s minimum common mode rejection
- -40 to +85°C temperature range
- Safety and regulatory approvals:
 - UL recognized
 - 3750 V_{rms} for 1 min. per UL 1577
 - 5000 V_{rms} for 1 min. per UL 1577 (for HCPL-772X option 020)
 - CSA component acceptance notice #5
 - IEC/EN/DIN EN 60747-5-5
 - V_{IORM} = 630 V_{peak} for HCPL-772X option 060
 - V_{IORM} = 567 V_{peak} for HCPL-072X option 060

Applications

- Digital fieldbus isolation: CC-Link, DeviceNet, PROFIBUS, SDS
- AC plasma display panel level shifting
- Multiplexed data transmission
- Computer peripheral interface
- Microprocessor system interface

Functional Diagram

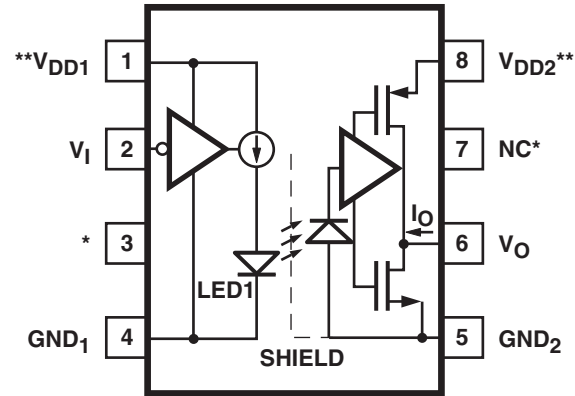

* Pin 3 is the anode of the internal LED and must be left unconnected for guaranteed data sheet performance. Pin 7 is not connected internally.

** A 0.01- μ F to 0.1- μ F bypass capacitor must be connected as close as possible between pins 1 and 4, and 5 and 8.

Truth Table

V _I Input	LED1	V _O Output
H	OFF	H
L	ON	L

Selection Guide

8-Pin DIP (300 Mil)	Small Outline SO-8	Data Rate	PWD
HCPL-7721	HCPL-0721	25 MB	6 ns
HCPL-7720	HCPL-0720	25 MB	8 ns

Ordering Information

HCPL-0720, HCPL-0721, HCPL-7720, and HCPL-7721 are UL Recognized with 3750 V_{rms} for 1 minute per UL1577.

Part Number	Option		Package	Surface Mount	Gull Wing	Tape & Reel	UL 5000 V _{rms} / 1 Minute rating	IEC/EN/DIN EN 60747-5-5	Quantity
	RoHS Compliant	Non RoHS Compliant							
HCPL-7720	-000E	no option	300 mil DIP-8						50 per tube
HCPL-7721	-300E	#300		X	X				50 per tube
	-500E	#500		X	X	X			1000 per reel
	-020E	-020					X		50 per tube
	-320E	-320		X	X		X		50 per tube
	-520E	-520		X	X	X	X		1000 per reel
	-060E	#060						X	50 per tube
	-360E	#360		X	X			X	50 per tube
	-560E	#560		X	X	X		X	1000 per reel
HCPL-0720	-000E	no option	SO-8	X	X				100 per tube
HCPL-0721	-500E	#500		X	X	X			1500 per reel
	-060E	#060		X	X			X	100 per tube
	-560E	#560		X	X	X		X	1500 per reel

To order, choose a part number from the part number column and combine with the desired option from the option column to form an order entry.

Example 1:

HCPL-7720-560E to order product of Gull Wing Surface Mount package in Tape and Reel packaging with IEC/EN/DIN EN 60747-5-5 Safety Approval and RoHS compliant.

Example 2:

HCPL-0721 to order product of Small Outline SO-8 package in Tube packaging and non RoHS compliant.

Option data sheets are available. Contact your Broadcom sales representative or authorized distributor for information.

NOTE: The notation #XXX is used for existing products, while (new) products launched since July 15, 2001 and RoHS compliant will use -XXXE.

Package Outline Drawing

HCPL-772X 8-Pin DIP Package

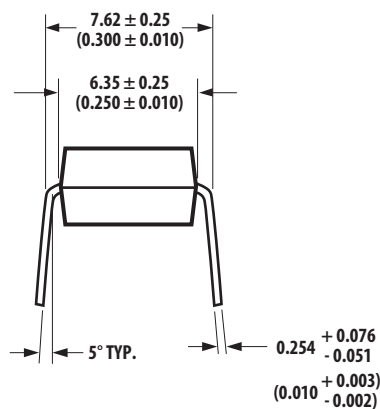
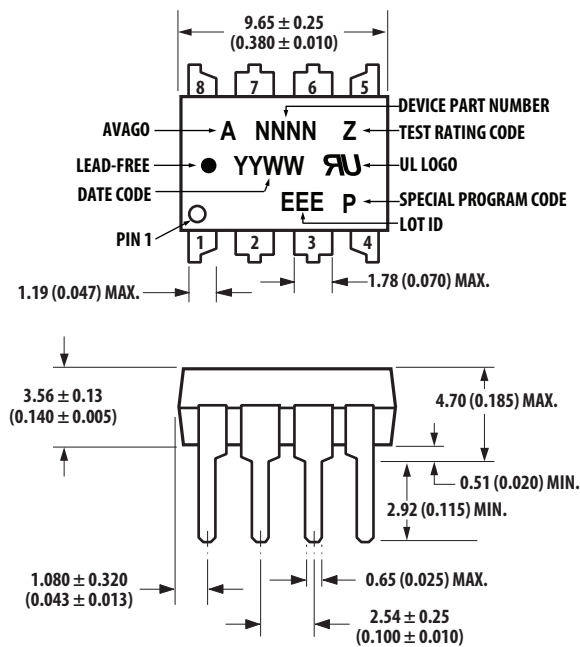

DIMENSIONS IN MILLIMETERS (INCHES).

*MARKING CODE LETTER FOR OPTION NUMBERS

"L" = OPTION 020

"V" = OPTION 060

OPTION NUMBERS 300 AND 500 NOT MARKED.

NOTE: FLOATING LEAD PROTRUSION IS 0.25 mm (10 mils) MAX.

HCPL-772X Package with Gull Wing Surface Mount Option 300

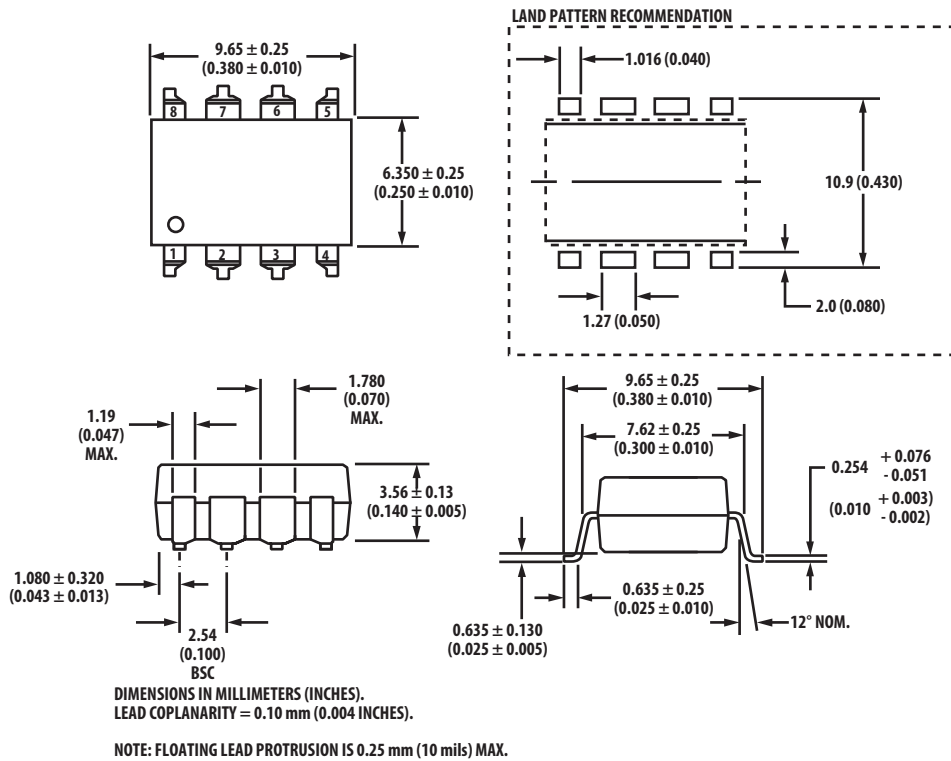

HCPL-072X Outline Drawing (Small Outline SO-8 Package)

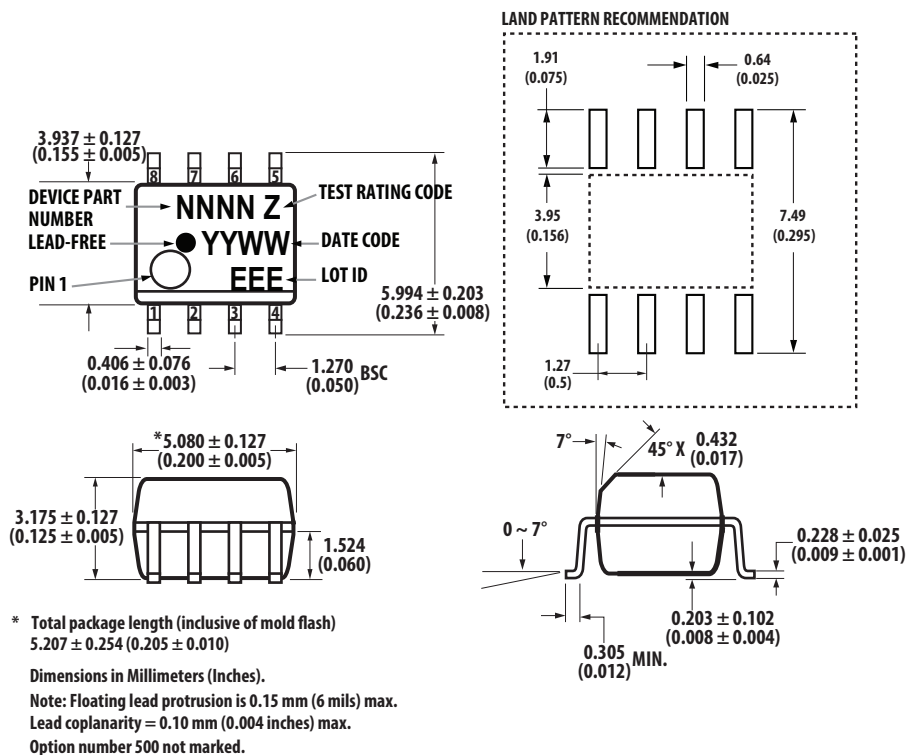

Reflow Soldering Profile

Recommended reflow condition as per JEDEC Standard, J-STD-020 (latest revision). Non-Halide Flux should be used.

Regulatory Information

The HCPL-772X/072X have been approved by the following organizations:

- **UL** — Recognized under UL1577, component recognition program, File E55361.
- **CSA** — Approval under CSA Component Acceptance Notice #5, File CA88324.
- **IEC/EN/DIN EN 60747-5-5**

Insulation and Safety Related Specifications

Parameter	Symbol	Value		Unit	Conditions
		772X	072X		
Minimum External Air Gap (Clearance)	L(I01)	7.1	4.9	mm	Measured from input terminals to output terminals, shortest distance through air.
Minimum External Tracking (Creepage)	L(I02)	7.4	4.8	mm	Measured from input terminals to output terminals, shortest distance path along body.
Minimum Internal Plastic Gap (Internal Clearance)		0.08	0.08	mm	Insulation thickness between emitter and detector; also known as distance through insulation.
Tracking Resistance (Comparative Tracking Index)	CTI	≥175	≥175	V	DIN IEC 112/VDE 0303 Part 1.
Isolation Group		IIIa	IIIa		Material Group (DIN VDE 0110, 1/89, Table 1).

All Broadcom data sheets report the creepage and clearance inherent to the optocoupler component itself. These dimensions are needed as a starting point for the equipment designer when determining the circuit insulation requirements. However, once mounted on a printed circuit board, minimum creepage and clearance requirements must be met as specified for individual equipment standards. For creepage, the shortest distance path along the surface of a printed circuit board between the solder fillets of the input and output leads must be considered. There are recommended techniques such as grooves and ribs, which may be used on a printed circuit board to achieve desired creepage and clearances. Creepage and clearance distances will also change depending on factors such as pollution degree and insulation level.

IEC/EN/DIN EN 60747-5-5 Insulation Characteristics (Option 060)

Description	Symbol	Characteristic		Unit
		HCPL-7720 HCPL-7721	HCPL-0720 HCPL-0721	
Installation Classification per DIN VDE 0110/39, Table 1 For Rated Mains Voltage $\leq 150V_{rms}$ For Rated Mains Voltage $\leq 300V_{rms}$ For Rated Mains Voltage $\leq 600V_{rms}$		I – IV I – IV I – IV	I – IV I – III I – III	
Climatic Classification		55/85/21	55/85/21	
Pollution Degree (DIN VDE 0110/39)		2	2	
Maximum Working Insulation Voltage	V_{IORM}	630	567	V_{peak}
Input-to-Output Test Voltage, Method b ^a $V_{IORM} \times 1.875 = V_{PR}$, 100% Production Test with $t_m = 1s$, Partial Discharge < 5 pC	V_{PR}	1181	1063	V_{peak}
Input-to-Output Test Voltage, Method a ^a $V_{IORM} \times 1.6 = V_{PR}$, Type and Sample Test, $t_m = 10s$, Partial Discharge < 5 pC	V_{PR}	1008	907	V_{peak}
Highest Allowable Overvoltage (Transient Overvoltage, $t_{ini} = 60s$)	V_{IOTM}	8000	6000	V_{peak}
Safety-Limiting Values – Maximum Values Allowed in the Event of a Failure Case Temperature Input Current Output Power	T_S $I_{S, INPUT}$ $P_{S, OUTPUT}$	175 230 600	150 150 600	$^{\circ}C$ mA mW
Insulation Resistance at T_S , $V_{IO} = 500V$	R_{IO}	$\geq 10^9$	$\geq 10^9$	Ω

a. Refer to the optocoupler section of the Isolation and Control Component Designer's Catalog, under Product Safety Regulations section IEC/EN/DIN EN 60747-5-5, for a detailed description of Method a and Method b partial discharge test profiles.

NOTE: These optocouplers are suitable for *safe electrical isolation* only within the safety limit data. Maintenance of the safety data shall be ensured by means of protective circuits.

Absolute Maximum Ratings

Parameter	Symbol	Min.	Max.	Unit
Storage Temperature	T_S	-55	125	$^{\circ}C$
Ambient Operating Temperature ^a	T_A	-40	85	$^{\circ}C$
Supply Voltages	V_{DD1}, V_{DD2}	0	6.0	V
Input Voltage	V_I	-0.5	$V_{DD1} + 0.5$	V
Output Voltage	V_O	-0.5	$V_{DD2} + 0.5$	V
Average Output Current	I_O	—	10	mA
Lead Solder Temperature	260 $^{\circ}C$ for 10 sec., 1.6 mm below seating plane.			
Solder Reflow Temperature Profile	See Reflow Soldering Profile section.			

a. Absolute maximum ambient operating temperature means the device will not be damaged if operated under these conditions. It does not guarantee functionality

Recommended Operating Conditions

Parameter	Symbol	Min.	Max.	Unit	Figure
Ambient Operating Temperature	T_A	-40	85	°C	
Supply Voltages	V_{DD1}, V_{DD2}	4.5	5.5	V	
Logic High Input Voltage	V_{IH}	2.0	V_{DD1}	V	1, 2
Logic Low Input Voltage	V_{IL}	0.0	0.8	V	
Input Signal Rise and Fall Times	t_{ir}, t_{if}	—	1.0	ms	

Electrical Specifications (DC)

Test conditions that are not specified can be anywhere within the recommended operating range.

All typical specifications are at $T_A = +25^\circ\text{C}$, $V_{DD1} = V_{DD2} = +5\text{V}$.

Parameter	Symbol	Min.	Typ.	Max.	Unit	Test Conditions	Fig	Note
Logic Low Input Supply Current	I_{DD1L}	—	6.0	10.0	mA	$V_I = 0\text{V}$		a
Logic High Input Supply Current	I_{DD1H}	—	1.5	3.0	mA	$V_I = V_{DD1}$		a
Output Supply Current	I_{DD2L}	—	7.7	9.0	mA			
	I_{DD2H}	—	5.8	9.0	mA			
Input Current	I_I	-10	—	10	μA			
Logic High Output Voltage	V_{OH}	4.4	5.0	—	V	$I_O = -20 \mu\text{A}, V_I = V_{IH}$	1, 2	
		4.0	4.8	—	V	$I_O = -4 \text{mA}, V_I = V_{IH}$		
Logic Low Output Voltage	V_{OL}	—	0	0.1	V	$I_O = 20 \mu\text{A}, V_I = V_{IL}$		
		—	—	0.1	V	$I_O = 400 \mu\text{A}, V_I = V_{IL}$		
		—	0.5	1.0	V	$I_O = 4 \text{mA}, V_I = V_{IL}$		

a. The LED is ON when V_I is low and OFF when V_I is high.

Switching Specifications (AC)

Parameter	Symbol	Min.	Typ.	Max.	Unit	Test Conditions	Fig.	Note
Propagation Delay Time to Logic Low Output	t_{PHL}	—	20	40	ns	$C_L = 15 \text{pF}$ CMOS Signal Levels	3, 6	a
Propagation Delay Time to Logic High Output	t_{PLH}	—	19	40	ns			
Pulse Width	PW	40	—	—	ns			
Data Rate		—	—	25	MBd			
Pulse Width Distortion $ t_{PHL} - t_{PLH} $	PWD	7721/0721	3	6	ns		7	b
		7720/0720	3	8	ns			
Propagation Delay Skew	t_{PSK}	—	—	20			c	
Output Rise Time (10% to 90%)	t_R	—	9	—	ns			
Output Fall Time (90% to 10%)	t_F	—	8	—	ns			

Parameter	Symbol	Min.	Typ.	Max.	Unit	Test Conditions	Fig.	Note
Common Mode	$ CM_H $	10	20	—	kV/ μ s	$V_I = V_{DD1}$, $V_O > 0.8 V_{DD1}$, $V_{CM} = 1000V$ $V_I = 0V$, $V_O > 0.8V$, $V_{CM} = 1000V$		d
Transient Immunity at Logic High Output		—	—	—				
Common Mode Transient Immunity at Logic Low Output	$ CM_L $	10	20	—				
Input Dynamic Power Dissipation Capacitance	C_{PD1}	—	60	—	pF			e
Output Dynamic Power Dissipation Capacitance	C_{PD2}	—	10	—				

- t_{PHL} propagation delay is measured from the 50% level on the falling edge of the V_I signal to the 50% level of the falling edge of the V_O signal. t_{PLH} propagation delay is measured from the 50% level on the rising edge of the V_I signal to the 50% level of the rising edge of the V_O signal.
- PWD is defined as $|t_{PHL} - t_{PLH}|$. %PWD (percent pulse width distortion) is equal to the PWD divided by pulse width.
- t_{PSK} is equal to the magnitude of the worst-case difference in t_{PHL} and/or t_{PLH} that will be seen between units at any given temperature within the recommended operating conditions.
- CM_H is the maximum common mode voltage slew rate that can be sustained while maintaining $V_O > 0.8V_{DD2}$. CM_L is the maximum common mode voltage slew rate that can be sustained while maintaining $V_O < 0.8V$. The common mode voltage slew rates apply to both rising and falling common mode voltage edges.
- Unloaded dynamic power dissipation is calculated as follows: $C_{PD} \times V_{DD2} \times f + I_{DD} \times V_{DD}$, where f is switching frequency in MHz.

Package Characteristics

Parameter	Symbol	Min.	Typ.	Max.	Unit	Test Conditions	Fig.	Note	
Input-Output Momentary Withstand Voltage	-072X	V_{ISO}	3750	—	—	V_{rms}	RH \leq 50%, $t = 1$ min, $T_A = 25^\circ C$		a, b, c
	-772X		3750	—	—				
	Option 020		5000	—	—				
Input-Output Resistance		R_{I-O}	—	10^{12}	—	Ω	$V_{I-O} = 500$ Vdc		a
Input-Output Capacitance		C_{I-O}	—	0.6	—	pF	$f = 1$ MHz		
Input Capacitance		C_I	—	3.0	—				d
Input IC Junction-to-Case Thermal Resistance	-772X	θ_{jci}	—	145	—	$^\circ C/W$	Thermocouple located at center underside of package		
	-072X		—	160	—				
Output IC Junction-to-Case Thermal Resistance	-772X	θ_{jco}	—	140	—	$^\circ C/W$			
	-072X		—	135	—				
Package Power Dissipation		P_{PD}	—	—	150	mW			

- Device considered a two-terminal device: pins 1, 2, 3, and 4 shorted together and pins 5, 6, 7, and 8 shorted together.
- In accordance with UL1577, each HCPL-072X is proof tested by applying an insulation test voltage $\geq 4500 V_{rms}$ for 1 second (leakage detection current limit, $I_{I-O} \leq 5 \mu A$). Each HCPL-772X is proof tested by applying an insulation test voltage $\geq 4500 V_{rms}$ for 1 second (leakage detection current limit, $I_{I-O} \leq 5 \mu A$).
- The Input-Output Momentary Withstand Voltage is a dielectric voltage rating that should not be interpreted as an input-output continuous voltage rating.
- C_I is the capacitance measured at pin 2 (V_I).

Figure 1: Typical Output Voltage vs. Input Voltage

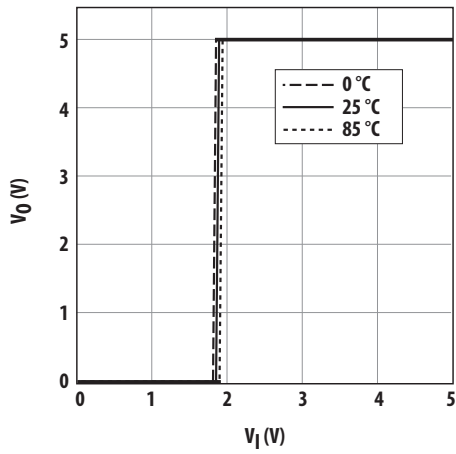

Figure 2: Typical Input Voltage Switching Threshold vs. Input Supply Voltage

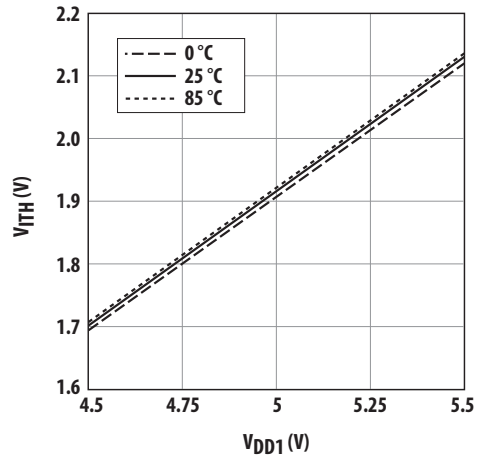

Figure 3: Typical Propagation Delays vs. Temperature

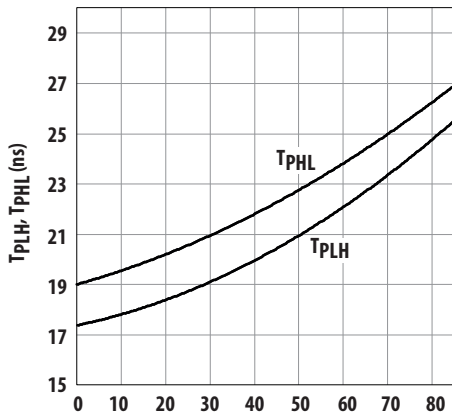

Figure 4: Typical Pulse Width Distortion vs. Temperature

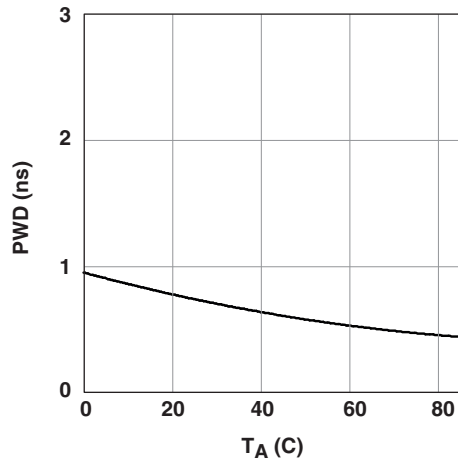

Figure 5: Typical Rise Time vs. Temperature

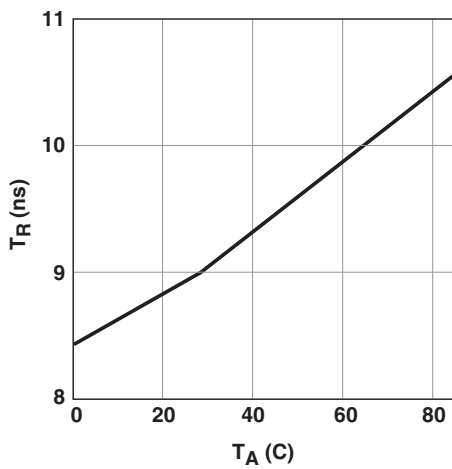

Figure 6: Typical Fall Time vs. Temperature

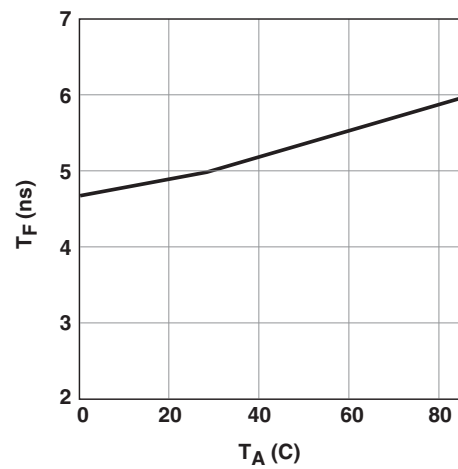

Figure 7: Typical Propagation Delays vs. Output Load Capacitance

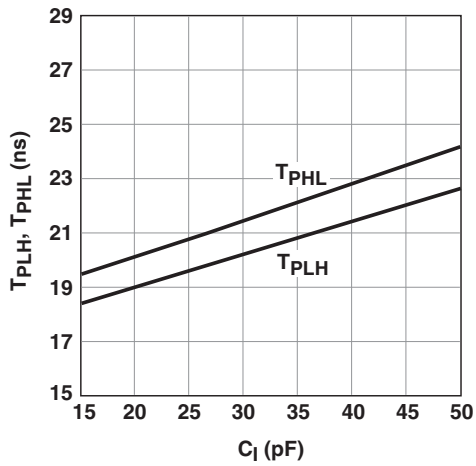

Figure 8: Typical Pulse Width Distortion vs. Output Load Capacitance

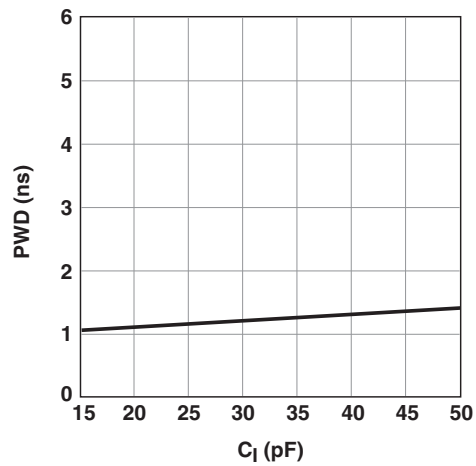
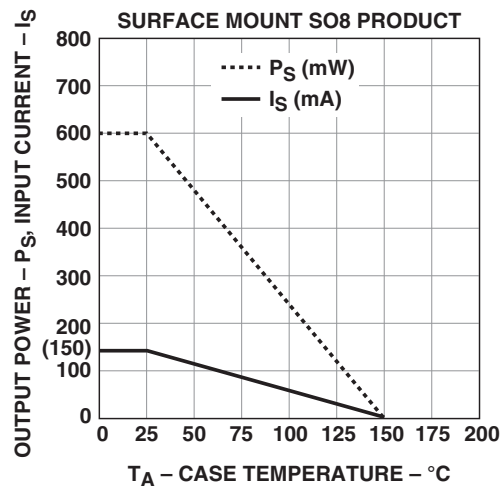
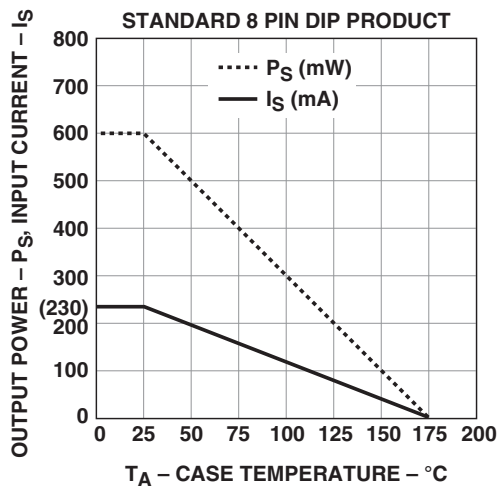

Figure 9: Thermal Derating Curve, Dependence of Safety Limiting Value with Case Temperature per IEC/EN/DIN EN 60747-5-5



Application Information

Bypassing and PC Board Layout

The HCPL-772X/072X optocouplers are extremely easy to use. No external interface circuitry is required because the HCPL-772X/072X use high-speed CMOS IC technology allowing CMOS logic to be connected directly to the inputs and outputs.

As shown in [Figure 10](#), the only external components required for proper operation are two bypass capacitors. Capacitor values should be between 0.01 μF and 0.1 μF . Each capacitor should be placed as close as possible to the input and output power-supply pins of the optocoupler.

Figure 10: Functional Diagram

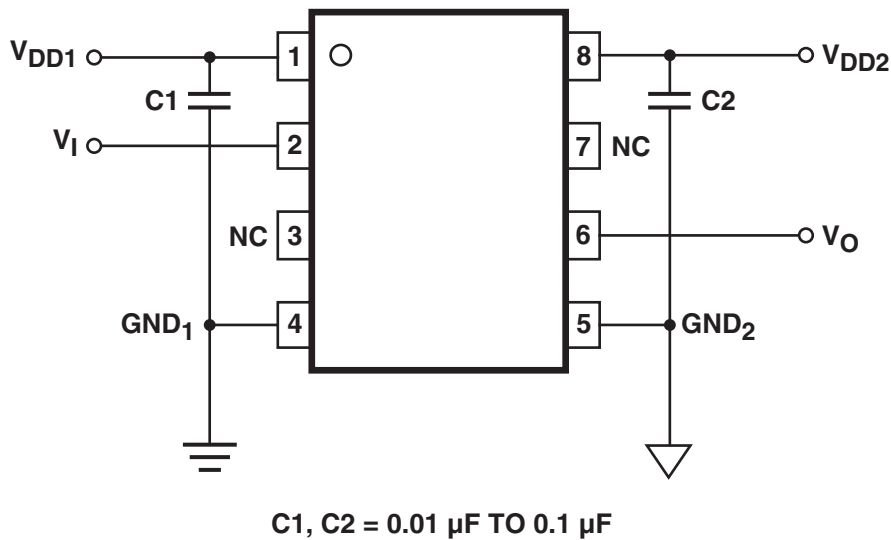

Digital Field Bus Communication Networks

To date, despite its many drawbacks, the 4 mA to 20 mA analog current loop has been the most widely accepted standard for implementing process control systems. In today's manufacturing environment, however, automated systems are expected to help manage the process, not merely monitor it. With the advent of digital field bus communication networks such as CC-Link, DeviceNet, PROFIBUS, and Smart Distributed Systems (SDS), gone are the days of constrained information. Controllers can now receive multiple readings from field devices (sensors, actuators, etc.) in addition to diagnostic information.

The physical model for each of these digital field bus communication networks is very similar as shown in [Figure 11](#). Each includes one or more buses, an interface unit, optical isolation, transceiver, and sensing and/or actuating devices.

Figure 11: Typical Field Bus Communication Physical Model

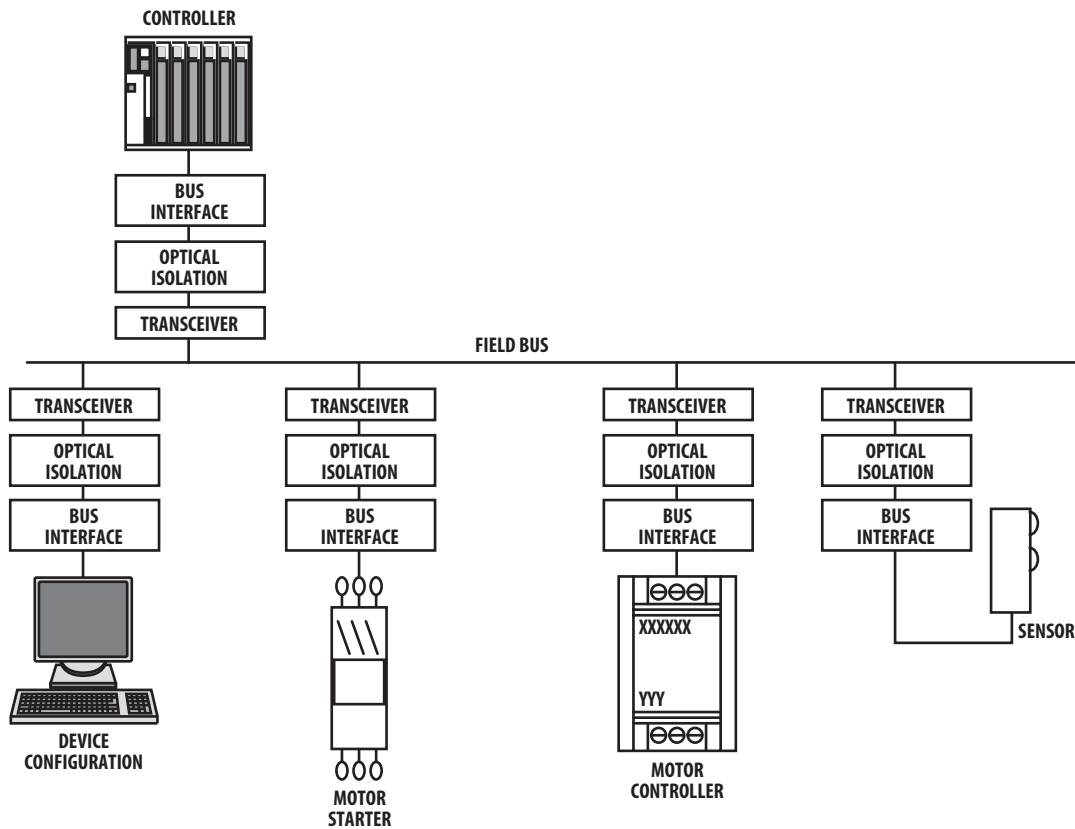

Optical Isolation for Field Bus Networks

To recognize the full benefits of these networks, Broadcom optocouplers are recommended to provide galvanic isolation. As network communication is bidirectional (involving receiving data from and transmitting data onto the network), two Broadcom optocouplers are needed. By providing galvanic isolation, data integrity is retained via noise reduction and the elimination of false signals. In addition, the network receives maximum protection from power system faults and ground loops.

Within an isolated node, such as the DeviceNet Node shown in [Figure 12](#), some of the node's components are referenced to a ground other than V₋ of the network.

These components could include such things as devices with serial ports, parallel ports, RS-232 and RS-485 type ports. As shown in [Figure 12](#), power from the network is used only for the transceiver and input (network) side of the optocouplers.

Isolation of nodes connected to any of the three types of digital field bus networks is best achieved by using the HCPL-772X/072X optocouplers. For each network, the HCPL-772X/072X satisfy the critical propagation delay and pulse width distortion requirements over the temperature range of 0°C to +85°C, and power supply voltage range of 4.5V to 5.5V.

Figure 12: Typical DeviceNet Node

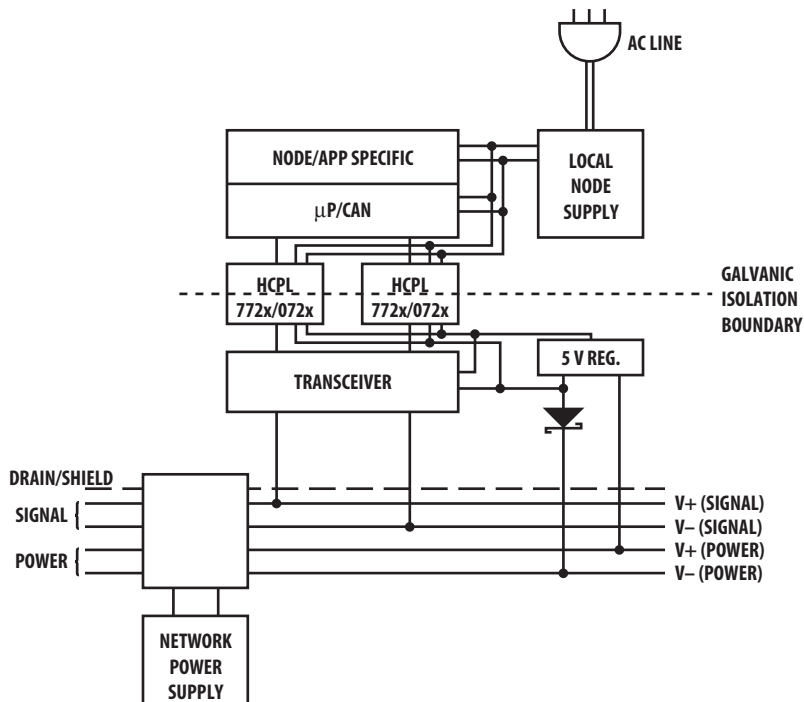

Implementing CC-Link with the HCPL-772X/072X

CC-Link (Control and Communication Link) is developed to merge control and information in the low-level network (field network) by PCs, thereby making the multivendor environment a reality. It has data control and message-exchange function, as well as bit control function, and operates at the speed up to 10 Mb/s.

The recommended CC-Link circuit is shown in Figure 13. Since the HCPL-772X/072X are fully compatible with CMOS logic level signals, the optocoupler is connected directly to the transceiver. Two bypass capacitors (with values between 0.01 μF and 0.1 μF) are required and should be located as close as possible to the input and output power supply pins of the HCPL-772X/072X. The bypass capacitors are required because of the high-speed digital nature of the signals inside the optocoupler.

Figure 13: Recommended CC-Link Application Circuit

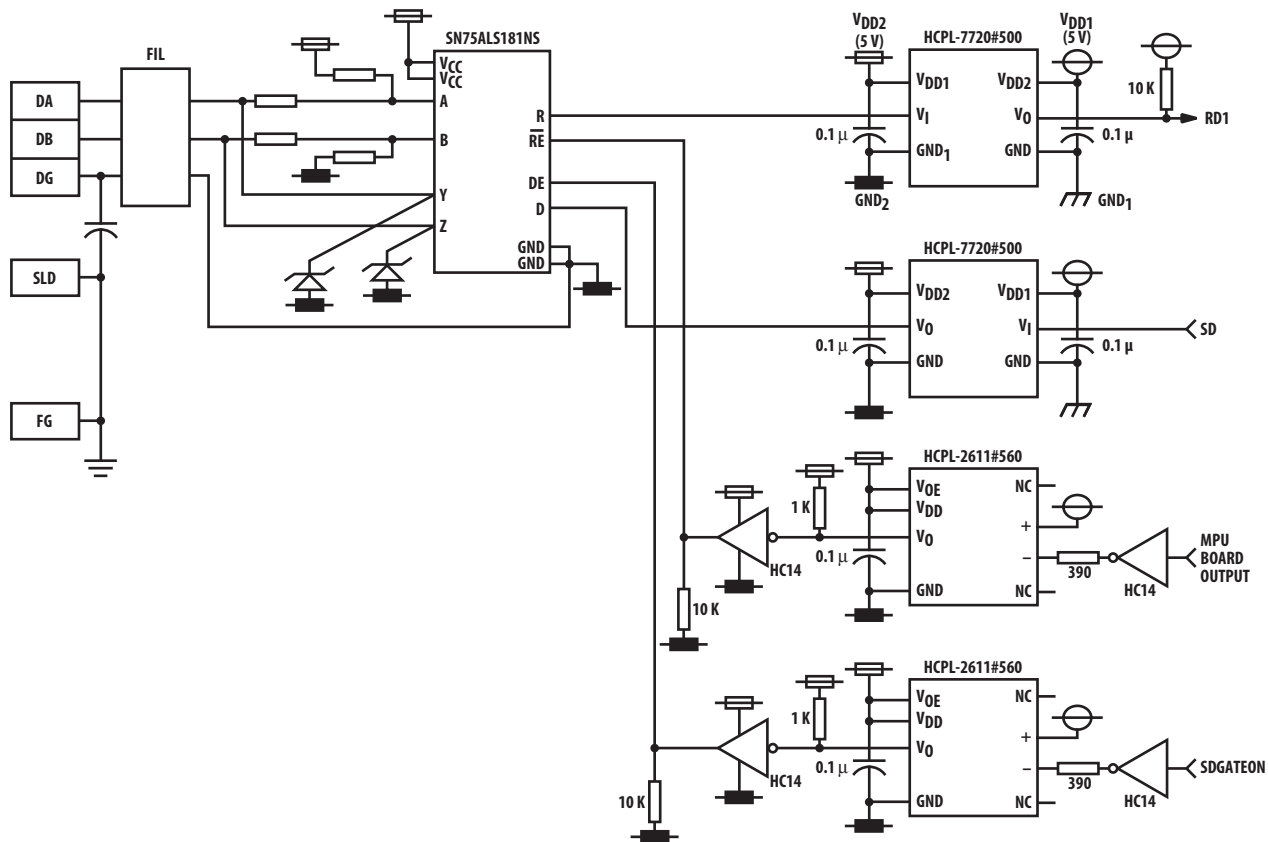

Implementing DeviceNet and SDS with the HCPL-772X/072X

With transmission rates up to 1 Mb/s, both DeviceNet and SDS are based upon the same broadcast-oriented, communications protocol: the Controller Area Network (CAN). Three types of isolated nodes are recommended for use on these networks: Isolated Node Powered by the Network (Figure 14), Isolated Node with Transceiver Powered by the Network (Figure 19), and Isolated Node Providing Power to the Network (Figure 16).

Isolated Node Powered by the Network

This type of node is very flexible and as can be seen in Figure 14, is regarded as *isolated* because not all of its components have the same ground reference. Yet, all components are still powered by the network. This node contains two regulators: one is isolated and powers the CAN controller, node-specific application and isolated (node) side of the two optocouplers while the other is non-isolated. The non-isolated regulator supplies the transceiver and the non-isolated (network) half of the two optocouplers.

Figure 14: Isolated Node Powered by the Network

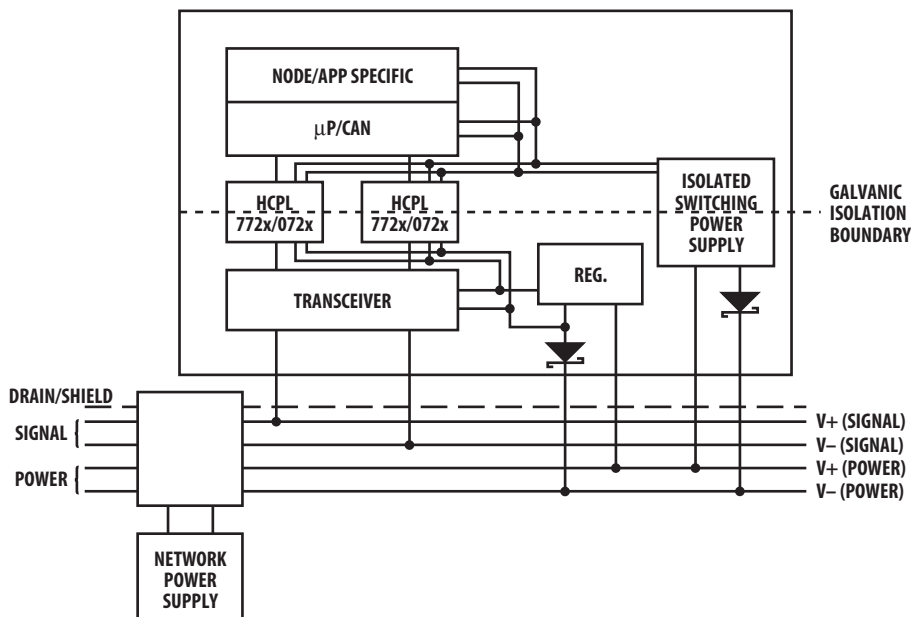

Isolated Node with Transceiver Powered by the Network

Figure 15 shows a node powered by both the network and another source. In this case, the transceiver and isolated (network) side of the two optocouplers are powered by the network. The rest of the node is powered by the AC line which is very beneficial when an application requires a significant amount of power. This method is also desirable as it does not heavily load the network.

More importantly, the unique *dual-inverting* design of the HCPL-772X/072X ensure the network will not *lock-up* if either AC line power to the node is lost or the node powered-off. Specifically, when input power (V_{DD1}) to the HCPL-772X/072X located in the transmit path is eliminated, a RECESSIVE bus state is ensured as the HCPL-772X/072X output voltage (V_O) go HIGH.

Bus V+ Sensing*

It is suggested that the Bus V+ sense block shown in Figure 15 be implemented. A locally powered node with an unpowered isolated Physical Layer will accumulate errors and become bus-off if it attempts to transmit. The Bus V+ sense signal would be used to change the BOI attribute of the DeviceNet Object to the *auto-reset* (01) value. Refer to Volume 1, Section 5.5.3. This would cause the node to continually reset until bus power was detected. Once power was detected, the BOI attribute would be returned to the *hold in bus-off* (00) value. The BOI attribute should not be left in the *auto-reset* (01) value since this defeats the jabber protection capability of the CAN error confinement. Any inexpensive low-frequency optical isolator can be used to implement this feature.

Figure 15: Isolated Node with Transceiver Powered by the Network

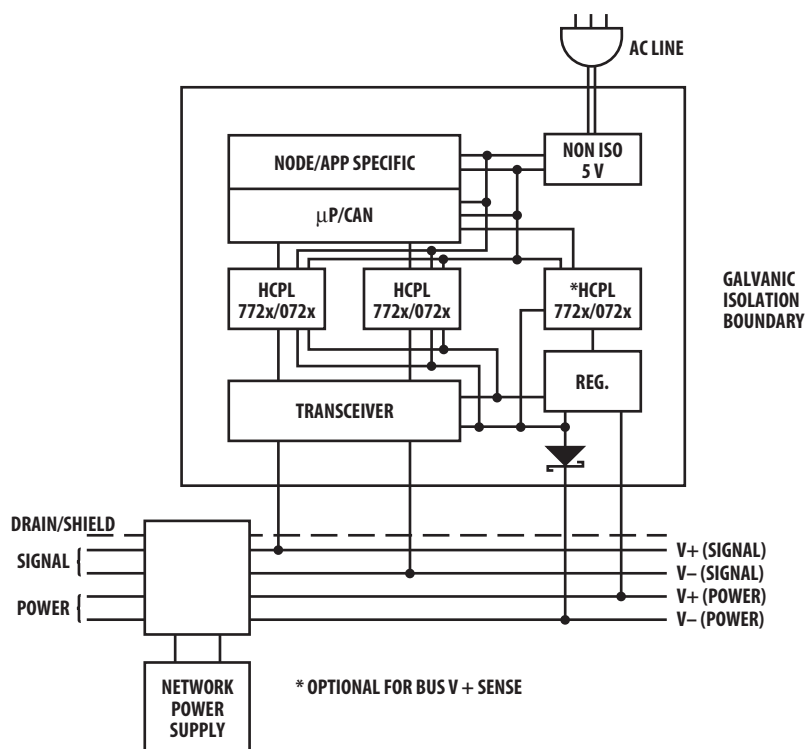

Isolated Node Providing Power to the Network

Figure 16 shows a node providing power to the network. The AC line powers a regulator which provides 5V locally. The AC line also powers a 24V isolated supply, which powers the network, and another 5V regulator, which, in turn, powers the transceiver and isolated (network) side of the two optocouplers. This method is recommended when there is a limited number of devices on the network, which do not require much power, thus eliminating the need for separate power supplies.

More importantly, the unique *dual-inverting* design of the HCPL-772X/072X ensure the network will not *lock-up* if either AC line power to the node is lost or the node powered-off. Specifically, when input power (V_{DD1}) to the HCPL-772X/072X located in the transmit path is eliminated, a RECESSIVE bus state is ensured as the HCPL-772X/072X output voltage (V_O) go HIGH.

Figure 16: Isolated Node Providing Power to the Network

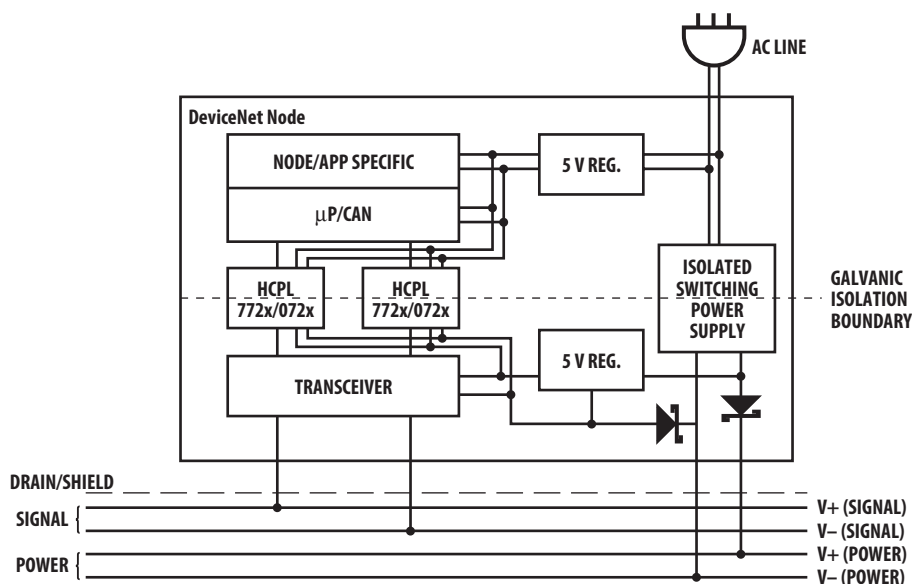

The recommended DeviceNet application circuit is shown in Figure 17. Since the HCPL-772X/072X are fully compatible with CMOS logic level signals, the optocoupler is connected directly to the CAN transceiver. Two bypass capacitors (with values between 0.01 μF and 0.1 μF) are required and should be located as close as possible to the input and output power-supply pins of the HCPL-772X/072X. The bypass capacitors are required because of the high-speed digital nature of the signals inside the optocoupler.

Figure 17: Recommended DeviceNet Application Circuit

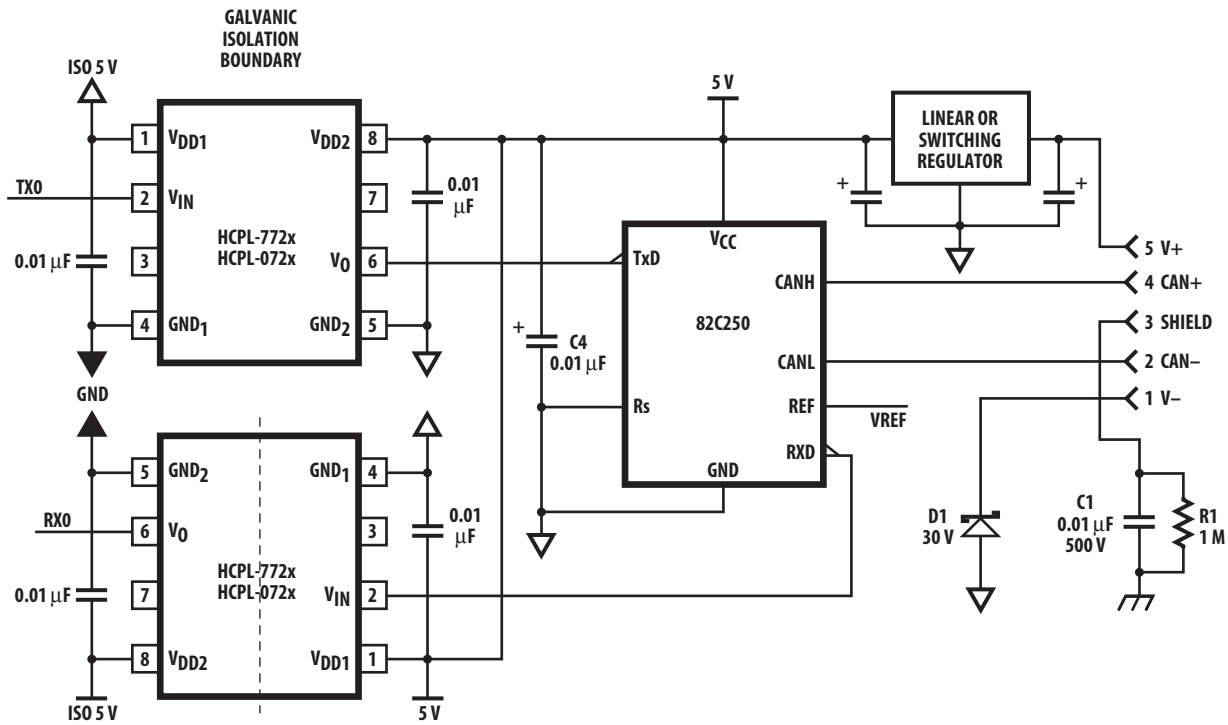

Implementing PROFIBUS with the HCPL-772X/072X

An acronym for Process Fieldbus, PROFIBUS is essentially a twisted-pair serial link very similar to RS-485 capable of achieving high-speed communication up to 12 MBd. As shown in [Figure 18](#), a PROFIBUS Controller (PBC) establishes the connection of a field automation unit (control or central processing station) or a field device to the transmission medium. The PBC consists of the line transceiver, optical isolation, frame character transmitter/receiver (UART), and the FDL/APP processor with the interface to the PROFIBUS user.

Figure 18: PROFIBUS Controller (PBC)

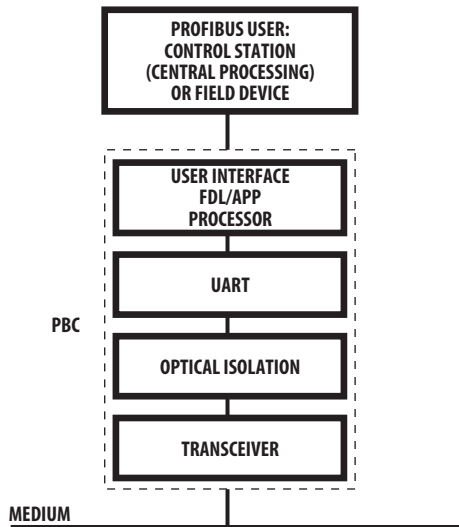

The recommended PROFIBUS application circuit is shown in [Figure 19](#). Since the HCPL-772X/072X are fully compatible with CMOS logic level signals, the optocoupler is connected directly to the transceiver. Two bypass capacitors (with values between 0.01 μF and 0.1 μF) are required and should be located as close as possible to the input and output power-supply pins of the HCPL-772X/072X. The bypass capacitors are required because of the high-speed digital nature of the signals inside the optocoupler.

Being very similar to multistation RS485 systems, the HCPL-061N optocoupler provides a transmit disable function which is necessary to make the bus free after each master/slave transmission cycle. Specifically, the HCPL-061N disables the transmitter of the line driver by putting it into a high state mode. In addition, the HCPL-061N switches the RX/TX driver IC into the listen mode. The HCPL-061N offers HCMOS compatibility and the high CMR performance (1 kV/ μs at $V_{\text{CM}} = 1000\text{V}$) essential in industrial communication interfaces.

Figure 19: Recommended PROFIBUS Application Circuit

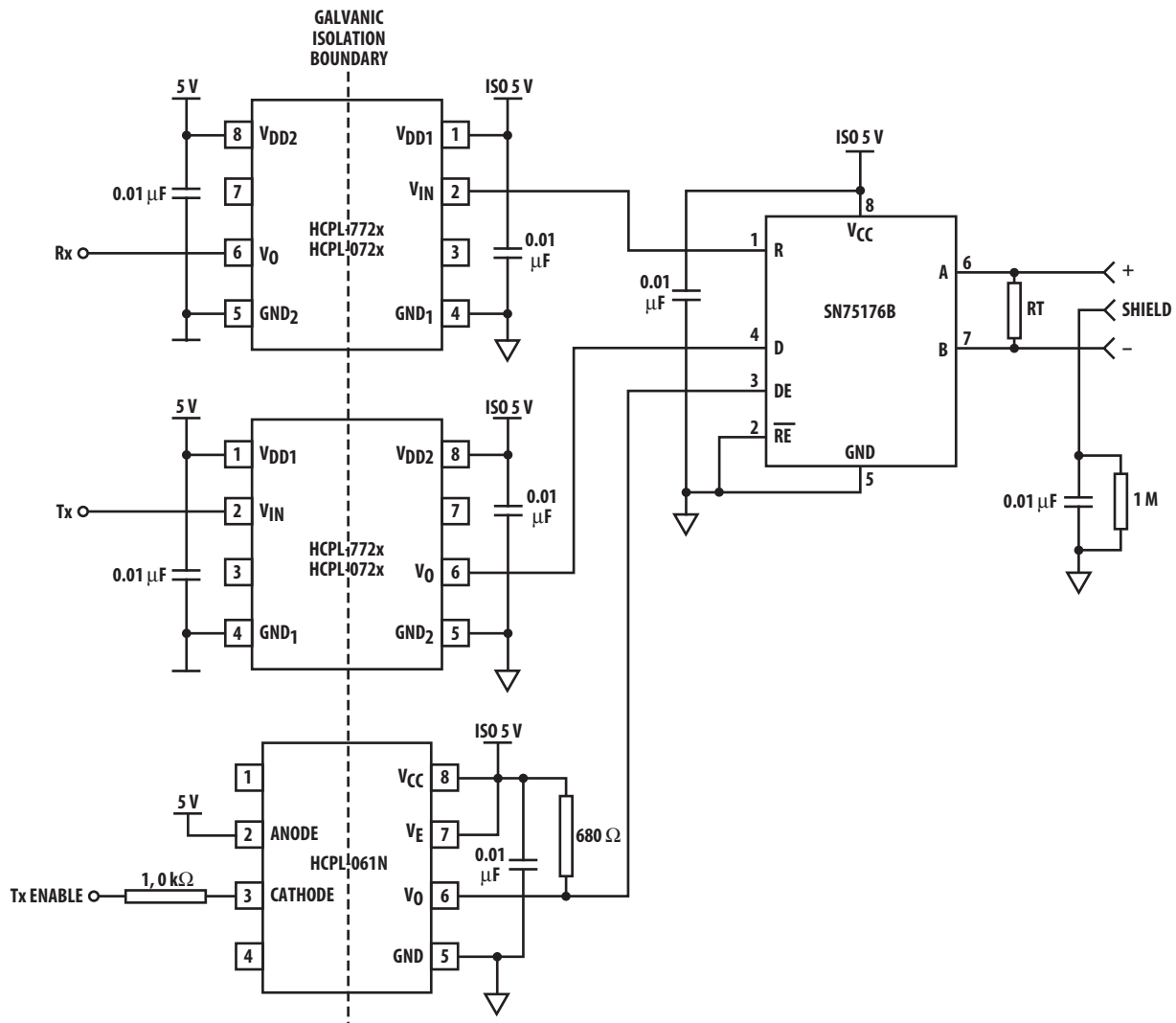

Broadcom, the pulse logo, Connecting everything, Avago Technologies, Avago, and the A logo are among the trademarks of Broadcom and/or its affiliates in the United States, certain other countries and/or the EU.

Copyright © 2017 by Broadcom. All Rights Reserved.

The term “Broadcom” refers to Broadcom Limited and/or its subsidiaries. For more information, please visit www.broadcom.com.

Broadcom reserves the right to make changes without further notice to any products or data herein to improve reliability, function, or design. Information furnished by Broadcom is believed to be accurate and reliable. However, Broadcom does not assume any liability arising out of the application or use of this information, nor the application or use of any product or circuit described herein, neither does it convey any license under its patent rights nor the rights of others.

