

IntelliMAX™ 28 V, Over-Voltage, Over-Current Protection Load Switch with Adjustable Current-Limit Control

FPF2495C

Description

The FPF2495C advanced load-management switch targets applications requiring a highly integrated solution. It disconnects loads powered from the DC power rail (<6 V) with stringent off-state current targets and high load capacitances (<100 μF). The FPF2495C consists of a slew-rate controlled low-impedance MOSFET switch (100 mΩ maximum) and integrated analog features. The slew-rate controlled turn-on characteristic prevents inrush current and the resulting excessive voltage droop on power rails. FPF2495C has over-voltage protection and over-temperature protection.

The FPF2495C has a True Reverse-Current Blocking (TRCB) function that obstructs unwanted reverse current from V_{OUT} to V_{IN} during ON and OFF states. The exceptionally low off-state current drain (<2 μA maximum) facilitates compliance with standby power requirements. The input voltage range operates from 2.5 V to 5.5 V_{DC} to support a wide range of applications in consumer, optical, medical, storage, portable, and industrial-device power management. Switch control is managed by a logic input (active HIGH) capable of interfacing directly with low-voltage control signal / General-Purpose Input / Output (GPIO) without an external pull-down resistor.

The device is packaged in advanced, fully “green” compliant, 1.21 mm x 1.21 mm, Wafer-Level Chip-Scale Package (WLCSP).

Features

- V_{IN} : 2.5 V~5.5 V
- 28 V Absolute Ratings at V_{OUT}
- Current Capability: 2 A
- Adjustable Current Limit: 0.05 A~2 A (Typ.)
 - ◆ 0.1 A~2 A with 10% Accuracy
 - ◆ < 0.1 A with 15% Accuracy
- R_{ON} : Maximum 100 mΩ at 5 V_{IN} and 1 A I_{OUT}
- Output OVP: Min. = 5.6 V, Typ. = 5.8 V, Max. = 6 V
- No Output Discharge During Off State
- Open-Drain OCP on FLAGB
- Thermal Shutdown
- Under-Voltage Lockout (UVLO)
- True Reverse-Current Blocking (TRCB)
- Logic CMOS IO Meets JESD76 Standard for GPIO Interface and Related Power Supply Requirements

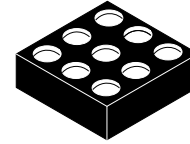

WLCSP9 1.21x1.21x0.586
 CASE 567RV

MARKING DIAGRAM

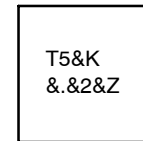

- T5 = Specific Device Code
- &K = Lot Run Traceability Code
- &. = Pin One Dot
- &2 = Date Code
- &Z = Assembly Plant Code

ORDERING INFORMATION

See detailed ordering and shipping information on page 2 of this data sheet.

- ESD Protected:
 - ◆ Human Body Model: >2 kV
 - ◆ Charged Device Model: >2.5 kV
 - ◆ IEC 61000-4-2 Air Discharge: >15 kV
 - ◆ IEC 61000-4-2 Contact Discharge: >8 kV
- UL Listed – File No. E467988 and IEC60950-1 (ed.2): am1
- This is a Pb-Free Device

Applications

- Smart Phones, Tablet PCs
- Storage, DSLR, and Portable Devices

FPF2495C

ORDERING INFORMATION

Part Number	Top Mark	Manufacturing	Operating Temperature Range	Package	Shipping†
FPF2495CUCX	T5	Multiple Assembly & Test Sites	-40 to 85°C	WLCSP9 1.21x1.21x0.586 (Pb-Free)	3000 / Tape & Reel

†For information on tape and reel specifications, including part orientation and tape sizes, please refer to our Tape and Reel Packaging Specifications Brochure, BRD8011/D.

APPLICATION DIAGRAM

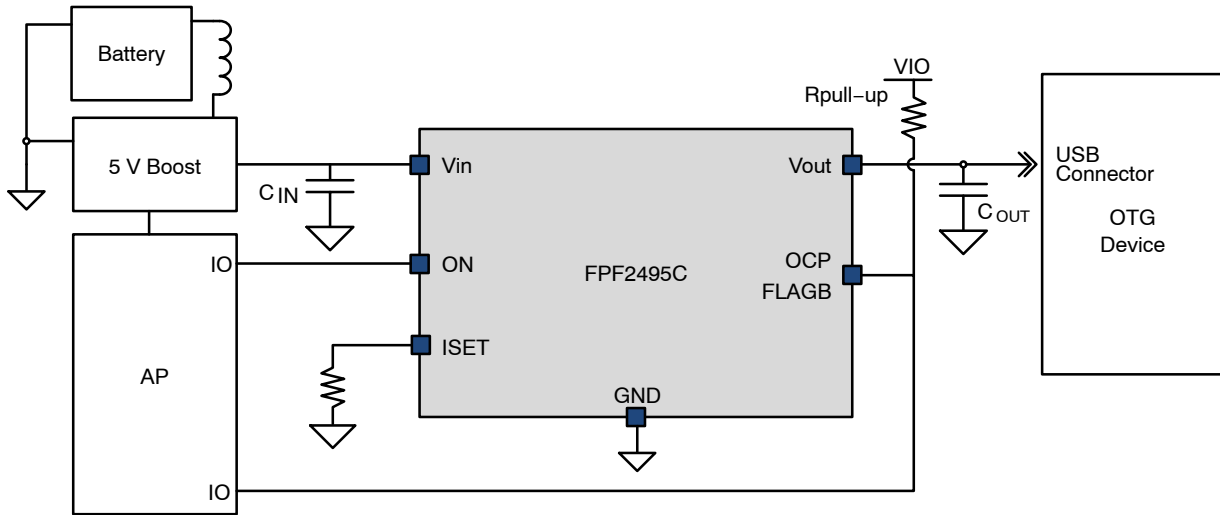

Figure 1. Typical Application

NOTE:

1. C_{IN} and C_{OUT} capacitors recommended for improvement of device stability.

FUNCTIONAL BLOCK DIAGRAM

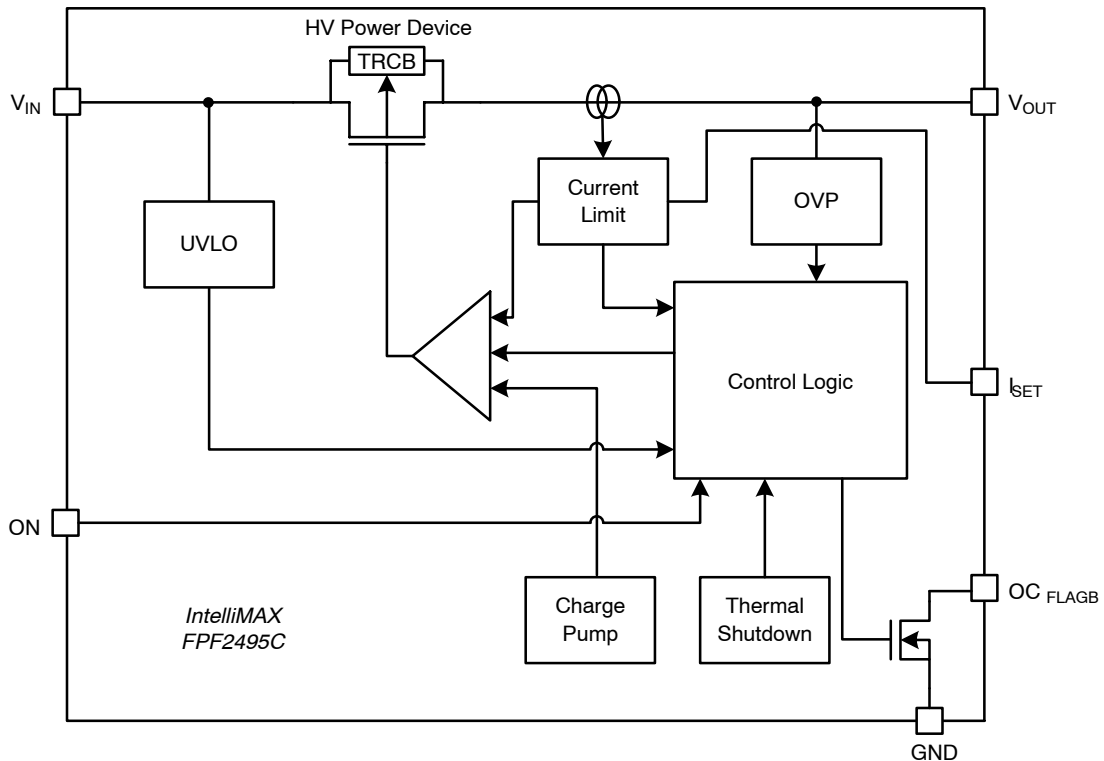

Figure 2. Functional Block Diagram

PIN CONFIGURATIONS

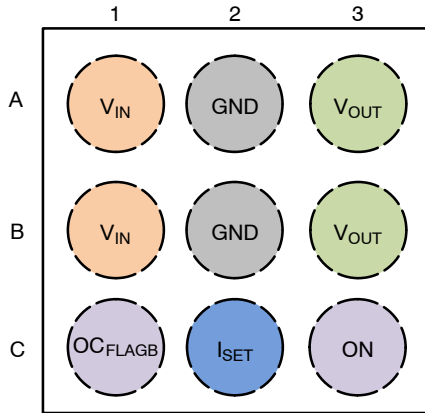

Figure 3. Pin Assignments (Top View)

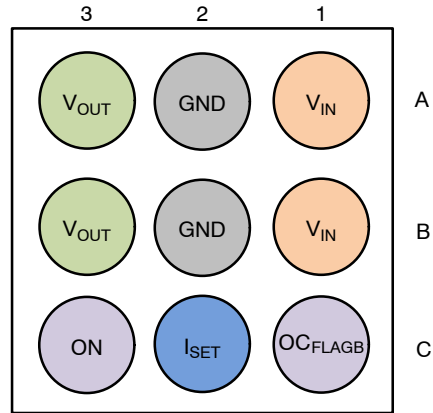

Figure 4. Pin Assignments (Bottom View)

PIN DESCRIPTION

Pin No.	Name	Description		
A3, B3	V _{OUT}	Switch Output		
A1, B1	V _{IN}	Supply Input: Input to the power switch		
A2	GND	Ground (true device ground)		
B2				
C3	ON	ON/OFF Control Input: Active HIGH – GPIO compatible	Logic HIGH	Switch Enable
			Logic LOW	Switch Disable
C1	OC _{FLAGB}	Fault Output: Active LOW, open–drain output that indicates an input over current. External pull–up resistor to V _{CC} is required.		
C2	I _{SET}	Current Limit Set Input: A resistor from ISET to ground sets the current limit for the switch.		

FPF2495C

ABSOLUTE MAXIMUM RATINGS

Symbol	Parameter	Parameter	Min	Max	Unit
V _{PIN}	V _{OUT} to GND, V _{OUT} to V _{IN}		-0.3	28.0	V
	ON, V _{IN} , FLAGB, I _{SET} to GND		-0.3	6.0	
I _{SW}	Maximum Continuous Switch Current (Note 4)		-	2.2	A
t _{PD}	Total Power Dissipation at T _A = 25°C		-	1.0	W
T _J	Operating Junction Temperature		-40	+150	°C
T _{STG}	Storage Junction Temperature		-65	+150	°C
Q _{JA}	Thermal Resistance, Junction-to-Ambient (1-inch Square Pad of 2 oz. Copper)		-	95 (Note 2)	°C/W
			-	110 (Note 3)	
ESD	Electrostatic Discharge Capability	Human Body Model, JESD22-A114	2.0	-	kV
		Charged Device Model, JESD22-C101	2.5	-	
	IEC61000-4-2 System Level	Air Discharge (V _{IN} , V _{ON} , V _{OUT} to GND)	15.0	-	
		Contact Discharge (V _{IN} , V _{ON} , V _{OUT} to GND)	8.0	-	

Stresses exceeding those listed in the Maximum Ratings table may damage the device. If any of these limits are exceeded, device functionality should not be assumed, damage may occur and reliability may be affected.

2. Measured using 2S2P JEDEC std. PCB.
3. Measured using 2S2P JEDEC PCB cold plate method.
4. Maximum Junction Temperature = 85°C.

RECOMMENDED OPERATING CONDITIONS *(Create - Table - RecOperating)*

Symbol	Parameter	Min	Max	Unit
V _{IN}	Supply Voltage	2.5	5.5	V
T _A	Ambient Operating Temperature	-40	85	°C

Functional operation above the stresses listed in the Recommended Operating Ranges is not implied. Extended exposure to stresses beyond the Recommended Operating Ranges limits may affect device reliability.

FPF2495C

ELECTRICAL CHARACTERISTICS

($V_{IN} = 2.5$ to 5.5 V, $T_A = -40$ to $+85^\circ\text{C}$; typical values are at $V_{IN} = 5$ V and $T_A = 25^\circ\text{C}$ unless otherwise noted)

Symbol	Parameter	Conditions	Min	Typ	Max	Unit
BASIC OPERATION						
V_{IN}	Input Voltage		2.5	–	5.5	V
$I_{Q(OFF)}$	Off Supply Current	$V_{ON} = \text{GND}$, $V_{OUT} = \text{Open}$	–	1	2	μA
$I_{SD(OFF)}$	Shutdown Current	$V_{IN} = 5.5$ V, $V_{OUT} = 0$ V, $V_{ON} = \text{GND}$	–	0.1	4.0	μA
I_Q	Quiescent Current	$I_{OUT} = 0$ mA	–	65	100	μA
R_{ON}	On Resistance	$V_{IN} = 5.0$ V, $I_{OUT} = 1$ A	–	70	100	m Ω
		$V_{IN} = 3.7$ V, $I_{OUT} = 1$ A	–	75	105	
R_{ON}	On Resistance (Note 6)	$V_{IN} = 5.0$ V, $I_{OUT} = 1.5$ A	–	70	–	m Ω
V_{IH}	ON Input Logic HIGH Voltage	$V_{IN} = 2.5$ V to 5.5 V	1.15	–	–	V
V_{IL}	ON Input Logic LOW Voltage	$V_{IN} = 2.5$ V to 5.5 V	–	–	0.65	V
V_{IL_FLAG}	FLAGB Output Logic LOW Voltage	$V_{IN} = 5$ V, $I_{SINK} = 10$ mA	–	0.1	0.2	V
		$V_{IN} = 2.5$ V, $I_{SINK} = 10$ mA	–	0.15	0.30	
I_{FLAGB_LK}	FLAGB Output HIGH Leakage Current	$V_{IN} = 5$ V, Switch On	–	–	1	μA
I_{ON}	On Input Leakage	$V_{ON} = 0$ V to V_{IN}	–	–	1.0	μA
R_{ON_PD}	Pull-Down Resistance at ON Pin	$V_{IN} = 2.5$ ~ 5.5 V, $V_{ON} = \text{HIGH}$, $T_A = -40$ to 85°C	–	14	–	M Ω

OVER-VOLTAGE PROTECTION

V_{OV_TRIP}	Output OVP Lockout	V_{OUT} Rising Threshold	5.50	5.80	6.00	V
		V_{OUT} Falling Threshold	–	5.50	–	
OUT_{HYS}	Output OVP Hysteresis	V_{OUT} Falling Threshold	–	0.3	–	V
t_{OVP}	OVP Response Time (Note 6)	$I_{OUT} = 0.5$ A, $C_L = 1$ μF , $T_A = 25^\circ\text{C}$, V_{OUT} from 5.5 V to 6.0 V	1	–	4 (Note 6)	μs

OVER-CURRENT PROTECTION

I_{LIM}	Current Limit	$V_{IN} = 5$ V, $R_{SET} = 9530$ Ω , $V_{OUT} = 1.68$ to 5 V with 25% Accuracy (Note 5)	80	107	134	mA
		$V_{IN} = 5$ V, $R_{SET} = 2100$ Ω , $V_{OUT} = 1.68$ to 5 V with 10% Accuracy (Note 5)	437	486	535	
		$V_{IN} = 5$ V, $R_{SET} = 1070$ Ω , $V_{OUT} = 1.68$ to 5 V with 10% Accuracy (Note 5)	858	953	1048	
V_{UVLO}	Under-Voltage Lockout	V_{IN} Increasing	–	2.4	–	V
		V_{IN} Decreasing	–	2.2	–	
V_{UVLO_HYS}	UVLO Hysteresis		–	200	–	mV
V_{T_RCB}	RCB Protection Trip Point	$V_{OUT} - V_{IN}$	–	50	–	mV
V_{R_RCB}	RCB Protection Release Trip Point	$V_{IN} - V_{OUT}$	–	50	–	mV
V_{RCB_HYS}	RCB Hysteresis		–	100	–	mV
t_{RCB}	Default RCB Response Time	$V_{IN} = 5$ V, $V_{ON} = \text{High / Low}$	–	2	–	μs
I_{RCB}	RCB Current	$V_{ON} = 0$ V, $V_{OUT} = 5.5$ V,	–	7	–	μA
t_{HOCP}	Hard Over-Current Response Time	Moderate Over-Current Condition, $I_{OUT} \geq I_{LIM}$, $V_{OUT} = 0$ V	–	6	–	μs
t_{OCP}	Over-Current Response Time	Moderate Over-Current Condition, $I_{OUT} \geq I_{LIM}$, $V_{OUT} \leq V_{IN}$	–	7	–	μs

FPF2495C

ELECTRICAL CHARACTERISTICS

($V_{IN} = 2.5$ to 5.5 V, $T_A = -40$ to $+85^\circ\text{C}$; typical values are at $V_{IN} = 5$ V and $T_A = 25^\circ\text{C}$ unless otherwise noted) (continued)

Symbol	Parameter	Conditions	Min	Typ	Max	Unit
t_{OC_FLAG}	Over-Current Flag Response Time	When Over-Current Occurs to Flag Pulling LOW	-	8	-	ms
TSD	Thermal Shutdown	Shutdown Threshold	-	150	-	$^\circ\text{C}$
		Return from Shutdown	-	130	-	
		Hysteresis	-	20	-	

DYNAMIC CHARACTERISTICS

t_{DON}	Turn-On Delay (Note 6, 7)	$V_{IN} = 5$ V, $R_L = 100 \Omega$, $C_L = 1 \mu\text{F}$, $T_A = 25^\circ\text{C}$, $R_{SET} = 2040 \Omega$	-	0.67	-	ms
t_R	V_{OUT} Rise Time (Note 6, 7)		-	0.69	-	ms
t_{ON}	Turn-On Time (Note 6, 8)		-	1.36	-	ms
t_{DOFF}	Turn-Off Delay (Note 6, 7)		-	0.01	-	ms
t_F	V_{OUT} Fall Time (Note 6, 7)		-	0.22	-	ms
t_{OFF}	Turn-Off Time (Note 6, 9)		-	0.23	-	ms
t_{DON}	Turn-On Delay (Note 7,10)	$V_{IN} = 5$ V, $R_L = 3.8 \Omega$, $C_L = 10 \mu\text{F}$, $T_A = -40$ to 85°C , $R_{SET} = 634 \Omega$	-	0.65	0.78	ms
t_R	V_{OUT} Rise Time (Note 7,10)		-	0.65	0.82	ms
t_{ON}	Turn-On Time (Note 8,10)		-	1.3	1.6	ms
t_{DOFF}	Turn-Off Delay (Note 7,10)		-	4	10	μs
t_F	V_{OUT} Fall Time (Note 7,10)		-	76	120	μs
t_{OFF}	Turn-Off Time (Note 9,10)		-	80	130	μs

Product parametric performance is indicated in the Electrical Characteristics for the listed test conditions, unless otherwise noted. Product performance may not be indicated by the Electrical Characteristics if operated under different conditions.

5. Characterization based on 1% tolerance resistor.
6. This parameter is guaranteed by design and characterization; not production tested.
7. $t_{DON} / t_{DOFF} / t_R / t_F$ are defined in Figure 5 below.
8. $t_{ON} = t_R + t_{DON}$.
9. $t_{OFF} = t_F + t_{DOFF}$.
10. This parameter is guaranteed by design.

TIMING DIAGRAM

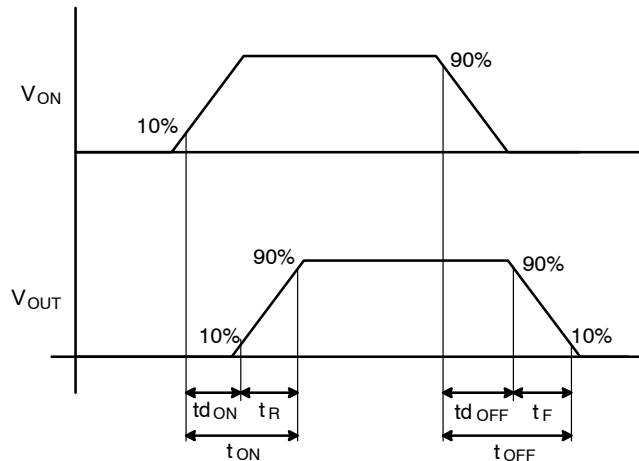

Where:

- t_{DON} = Delay On Time
- t_R = V_{OUT} Rise Time
- t_{ON} = Turn-On Time
- t_{DOFF} = Delay Off Time
- t_F = V_{OUT} Fall Time
- t_{OFF} = Turn Off Time

Figure 5. Timing Diagram

OPERATION AND APPLICATION DESCRIPTION

Input Capacitor

To limit the voltage drop on the input supply caused by transient inrush current when the switch turns on into discharge load capacitor; a capacitor must be placed in between the V_{IN} and GND pins. A high-value capacitor on C_{IN} can be used to reduce the voltage drop in high-current applications.

Output Capacitor

An output capacitor should be placed between the V_{OUT} and GND pins. This capacitor prevents parasitic board inductance from forcing V_{OUT} below GND when the switch is on. This capacitor also prevents reverse inrush current from creating a voltage spike that could damage the device in the case of a V_{OUT} short.

Fault Reporting

Upon the detection of an over-current, OC_FLAGB signal the fault by activating LOW.

Current Limiting

The current limit ensures that the current through the switch does not exceed the maximum set value, while not limiting the minimum value. The current at which the part's limit is adjustable through the selection of the external resistor connected to the ISET pin. Information for selecting the resistor is found in the section below. The device acts as a constant-current source when the load draws more than the maximum value set by the device until thermal shutdown occurs. The device recovers if the die temperature drops below the threshold temperature.

Under-Voltage Lockout (UVLO)

The under-voltage lockout turns the switch off if the input voltage drops below the lockout threshold. With the ON pin active, the input voltage rising above the UVLO threshold releases the lockout and enables the switch.

True Reverse-Current Blocking

The true reverse-current blocking feature protects the input source against current flow from output to input regardless of whether the load switch is on or off.

Thermal Shutdown

The thermal shutdown protects the die from internally or externally generated excessive temperature. During an over-temperature condition, the switch is turned off. The switch automatically turns on again if the temperature of the die drops below the threshold temperature.

Setting Current Limit

The current limit is set with an external resistor connected between the ISET and GND pins. The resistor is selected using the formula:

$$I_{LIM} \text{ (mA)} = ((0.4 / R_{SET} \Omega) \times 2550) \times 1000$$

Resistor tolerance of 1% or less is recommended.

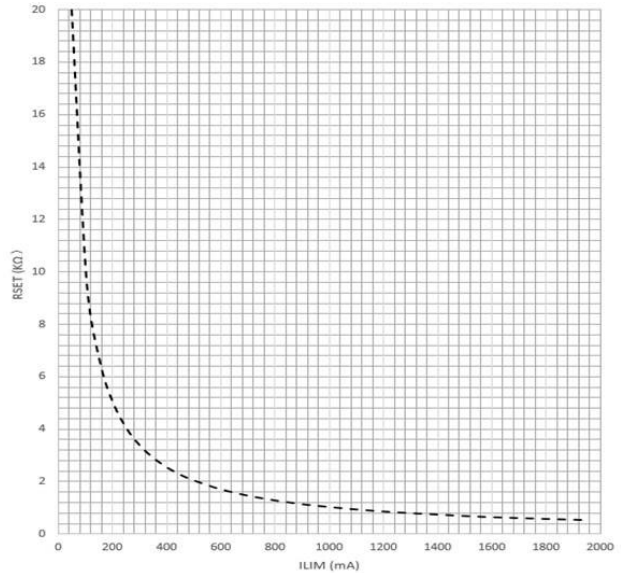

Figure 6. Current Limit Settings by R_{SET} (Note 11)

11. Values based on 1% tolerance resistor.

BOARD LAYOUT

For best performance, all traces should be as short as possible. To be most effective, the input and output capacitors should be placed close to the device to minimize the effect that parasitic trace inductance may have on normal and short-circuit operation. Using wide traces for V_{IN}, V_{OUT}, GND helps minimize parasitic electrical effects along with minimizing the case-to-ambient thermal impedance.

FPF2495C

TYPICAL PERFORMANCE CHARACTERISTICS ($T_A = 25^\circ\text{C}$)

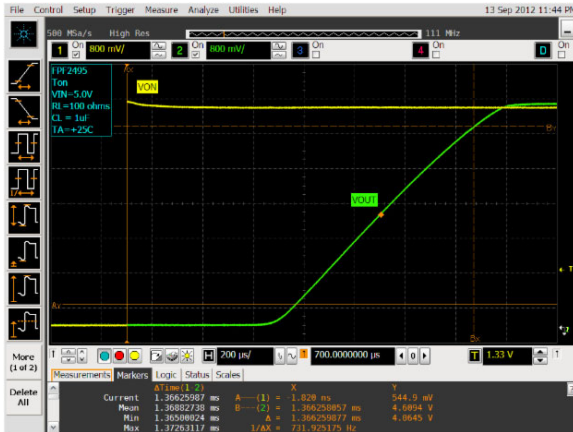

Figure 7. t_{ON} Response



Figure 8. OVP Response
(Increase V_{OUT} to OVP Trip Point)

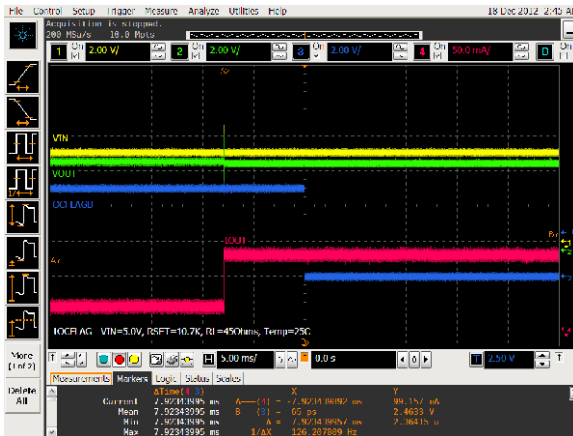

Figure 9. OC_FLAGB Response Time
(Toggle R_{LOAD} from High to Low Resistance)



Figure 10. t_{OFF} Response

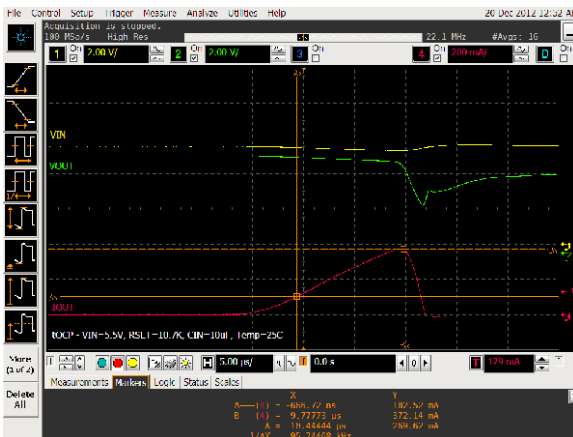
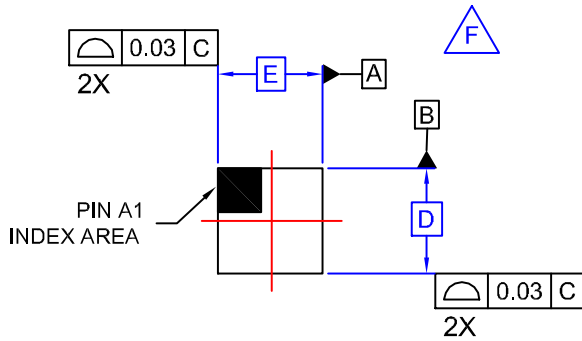

Figure 11. t_{OCP} Response Time

FPF2495C

PACKAGE DIMENSIONS

WLCSP9 1.21x1.21x0.586
CASE 567RV
ISSUE O



TOP VIEW

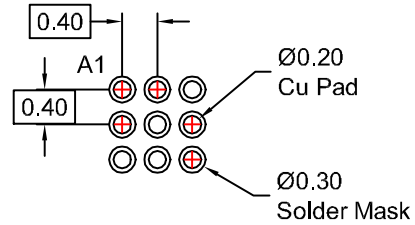

LAND PATTERN RECOMMENDATION
(NSMD PAD TYPE)

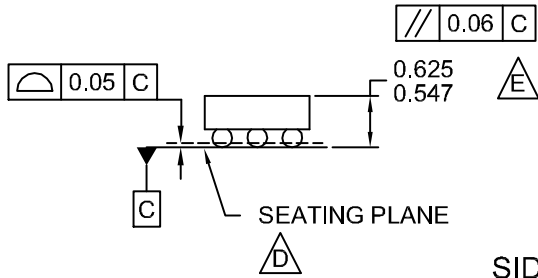

SIDE VIEWS

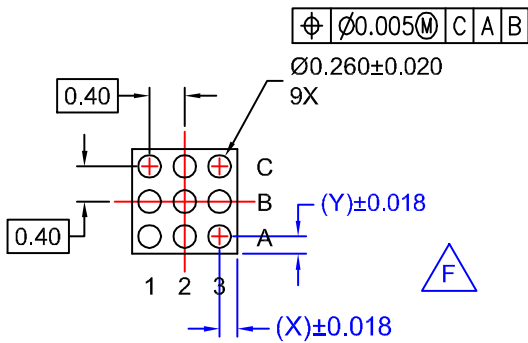
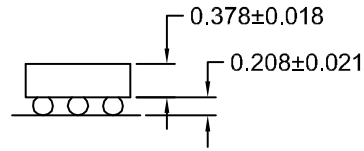

BOTTOM VIEW

NOTES:

- A. NO JEDEC REGISTRATION APPLIES.
- B. DIMENSIONS ARE IN MILLIMETERS.
- C. DIMENSIONS AND TOLERANCE PER ASMEY14.5M, 1994.
- D. DATUM C IS DEFINED BY THE SPHERICAL CROWNS OF THE BALLS.
- E. PACKAGE NOMINAL HEIGHT IS 586 MICRONS ±39 MICRONS (547-625 MICRONS).
- F. FOR DIMENSIONS D, E, X, AND Y SEE PRODUCT DATASHEET.

Table 1. PRODUCT-SPECIFIC DIMENSIONS

D	E	X	Y
1210 μm ±30 μm	1210 μm ±30 μm	205 μm	205 μm

IntelliMAX is trademark of Semiconductor Components Industries, LLC (SCILLC) or its subsidiaries in the United States and/or other countries.

onsemi, **Onsemi**, and other names, marks, and brands are registered and/or common law trademarks of Semiconductor Components Industries, LLC dba "**onsemi**" or its affiliates and/or subsidiaries in the United States and/or other countries. **onsemi** owns the rights to a number of patents, trademarks, copyrights, trade secrets, and other intellectual property. A listing of **onsemi**'s product/patent coverage may be accessed at www.onsemi.com/site/pdf/Patent-Marking.pdf. **onsemi** reserves the right to make changes at any time to any products or information herein, without notice. The information herein is provided "as-is" and **onsemi** makes no warranty, representation or guarantee regarding the accuracy of the information, product features, availability, functionality, or suitability of its products for any particular purpose, nor does **onsemi** assume any liability arising out of the application or use of any product or circuit, and specifically disclaims any and all liability, including without limitation special, consequential or incidental damages. Buyer is responsible for its products and applications using **onsemi** products, including compliance with all laws, regulations and safety requirements or standards, regardless of any support or applications information provided by **onsemi**. "Typical" parameters which may be provided in **onsemi** data sheets and/or specifications can and do vary in different applications and actual performance may vary over time. All operating parameters, including "Typicals" must be validated for each customer application by customer's technical experts. **onsemi** does not convey any license under any of its intellectual property rights nor the rights of others. **onsemi** products are not designed, intended, or authorized for use as a critical component in life support systems or any FDA Class 3 medical devices or medical devices with a same or similar classification in a foreign jurisdiction or any devices intended for implantation in the human body. Should Buyer purchase or use **onsemi** products for any such unintended or unauthorized application, Buyer shall indemnify and hold **onsemi** and its officers, employees, subsidiaries, affiliates, and distributors harmless against all claims, costs, damages, and expenses, and reasonable attorney fees arising out of, directly or indirectly, any claim of personal injury or death associated with such unintended or unauthorized use, even if such claim alleges that **onsemi** was negligent regarding the design or manufacture of the part. **onsemi** is an Equal Opportunity/Affirmative Action Employer. This literature is subject to all applicable copyright laws and is not for resale in any manner.

PUBLICATION ORDERING INFORMATION

LITERATURE FULFILLMENT:
Email Requests to: orderlit@onsemi.com

TECHNICAL SUPPORT
North American Technical Support:
Voice Mail: 1 800-282-9855 Toll Free USA/Canada
Phone: 011 421 33 790 2910

Europe, Middle East and Africa Technical Support:
Phone: 00421 33 790 2910
For additional information, please contact your local Sales Representative