

FOD410, FOD4108, FOD4116, FOD4118 6-Pin DIP Zero-Cross Triac Drivers

Features

- 300mA on-state current
- Zero-voltage crossing
- High blocking voltage
 - 800V (FOD4108, FOD4118)
 - 600V (FOD410, FOD4116)
- High trigger sensitivity
 - 1.3mA (FOD4116, FOD4118)
 - 2mA (FOD410, FOD4108)
- High static dv/dt (10,000V/μs)
- UL, VDE, CSA approved
- Lead free assembly

Applications

- Solid-state relays
- Industrial controls
- Lighting controls
- Static power switches
- AC motor starters

Description

The FOD410, FOD4108, FOD4116 and FOD4118 devices consist of an infrared emitting diode coupled to a hybrid triac formed with two inverse parallel SCRs which form the triac function capable of driving discrete triacs. The FOD4116 and FOD4118 utilize a high efficiency infrared emitting diode which offers an improved trigger sensitivity. These devices are housed in a standard 6-pin dual in-line (DIP) package.

Package

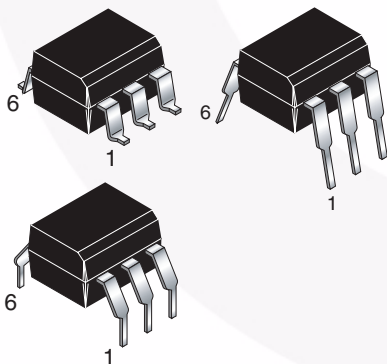

Schematic

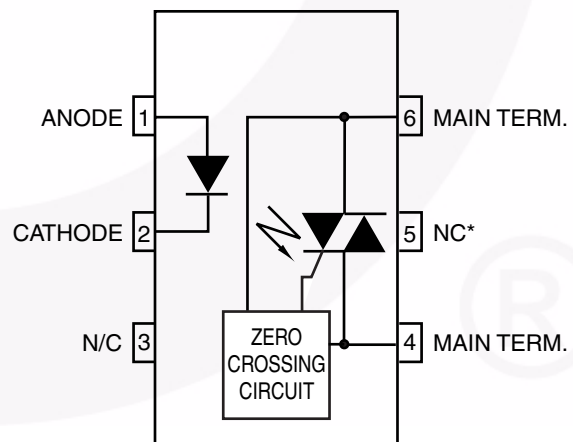

*DO NOT CONNECT
(TRIAC SUBSTRATE)

Absolute Maximum Ratings ($T_A = 25^\circ\text{C}$ unless otherwise noted)

Stresses exceeding the absolute maximum ratings may damage the device. The device may not function or be operable above the recommended operating conditions and stressing the parts to these levels is not recommended. In addition, extended exposure to stresses above the recommended operating conditions may affect device reliability. The absolute maximum ratings are stress ratings only.

Symbol	Parameters	Device	Value	Units
TOTAL DEVICE				
T_{STG}	Storage Temperature	All	-55 to +150	$^\circ\text{C}$
T_{OPR}	Operating Temperature	All	-55 to +100	$^\circ\text{C}$
T_{SOL}	Lead Solder Temperature (Wave)	All	260 for 10 sec	$^\circ\text{C}$
T_J	Junction Temperature Range	All	125	$^\circ\text{C}$
V_{ISO}	Isolation Test Voltage ⁽¹⁾ (rms AC voltage, 60Hz, 1 min. duration)	All	5000	Vac(rms)
P_D	Total Device Power Dissipation @ 25°C Derate above 25°C	All	500	mW
			8.3	mW/ $^\circ\text{C}$
EMITTER				
I_F	Continuous Forward Current	All	30	mA
V_R	Reverse Voltage	All	6	V
P_D	Total Power Dissipation 25°C Ambient Derate above 25°C	All	50	mW
			5.4	mW/ $^\circ\text{C}$
DETECTOR				
V_{DRM}	Off-State Output Terminal Voltage	FOD410, FOD4116	600	V
		FOD4108, FOD4118	800	
I_{TSM}	Peak Non-Repetitive Surge Current (single cycle 60Hz sine wave)	All	3	A
I_{TM}	Peak On-State Current	All	300	mA
P_D	Total Power Dissipation @ 25°C Ambient Derate above 25°C	All	450	mW
			6.25	mW/ $^\circ\text{C}$

Note:

1. Isolation voltage, V_{ISO} , is an internal device dielectric breakdown rating. For this test, Pins 1, 2 and 3 are common, and Pins 4, 5 and 6 are common.

Electrical Characteristics (T_A = 25°C Unless otherwise specified)

Individual Component Characteristics

Symbol	Parameters	Test Conditions	Device	Min.	Typ.*	Max	Units
EMITTER							
V _F	Input Forward Voltage	I _F = 20mA	All		1.25	1.5	V
I _R	Reverse Leakage Current	V _R = 6V	All		0.0001	10	μA
DETECTOR							
I _{D(RMS)}	Peak Blocking Current, Either Direction	I _F = 0, T _A = 100°C ⁽²⁾	V _D = 800V	FOD4108, FOD4118	3	100	μA
			V _D = 600V	FOD410, FOD4116			
I _{R(RMS)}	Reverse Current	T _A = 100°C	V _D = 800V	FOD4108, FOD4118	3	100	μA
			V _D = 600V	FOD410, FOD4116			
dv/dt	Critical Rate of Rise of Off-State Voltage	I _F = 0 ⁽⁴⁾ (Fig. 11)		10,000			V/μs

Transfer Characteristics

Symbol	DC Characteristics	Test Conditions	Device	Min.	Typ.*	Max.	Units
I _{FT}	LED Trigger Current	Main Terminal Voltage = 5V ⁽³⁾	FOD410, FOD4108		0.65	2.0	mA
			FOD4116, FOD4118		0.65	1.3	
V _{TM}	Peak On-State Voltage, Either Direction	I _{TM} = 300 mA peak, I _F = rated I _{FT}	All		2.2	3	V
I _H	Holding Current, Either Direction	V _T = 3V	All		200	500	μA
I _L	Latching Current	V _T = 2.2V	All		5		mA
t _{ON}	Turn-On Time	PF = 1.0, I _T = 300mA	V _{RM} = V _{DM} = 565 VAC	FOD4108		60	μs
			V _{RM} = V _{DM} = 424 VAC	FOD410, FOD4116, FOD4118			
t _{OFF}	Turn-Off Time		V _{RM} = V _{DM} = 565 VAC	FOD4108		52	μs
			V _{RM} = V _{DM} = 424 VAC	FOD410, FOD4116, FOD4118			
dv/dt _{crq}	Critical Rate of Rise of Voltage at Current Commutation	V _D = 0.67 V _{DRM} , di/dt _{crq} ≤ 15 A/ms	T _j = 25°C	All	10,000		V/μs
			T _j = 80°C		5,000		
di/dt _{cr}	Critical Rate of Rise of On-State Current		All			8	A/μs
dV(IO)/dt	Critical Rate of Rise of Coupled Input/Output Voltage	I _T = 0A, V _{RM} = V _{DM} = 424VAC	All		10,000		V/μs

*Typical values at T_A = 25°C

Electrical Characteristics (T_A = 25°C Unless otherwise specified) (Continued)

Zero Crossing Characteristics

Symbol	DC Characteristics	Test Conditions	Min.	Typ.*	Max.	Units
V _{INH}	Inhibit Voltage (MT1-MT2 voltage above which device will not trigger)	I _F = Rated I _{FT}		8	25	V
I _{DRM2}	Leakage in Inhibited State	I _F = Rated I _{FT} , Rated V _{DRM} , off state		20	200	μA

Isolation Characteristics

Symbol	Characteristics	Test Conditions	Min.	Typ.*	Max.	Units
V _{ISO}	Input-Output Isolation Voltage	f = 60Hz, t = 1 min. ⁽⁵⁾	5000			Vac(rms)

*Typical values at T_A = 25°C

Notes:

- Test voltage must be applied within dv/dt rating.
- All devices are guaranteed to trigger at an I_F value less than or equal to max I_{FT}. Therefore, recommended operating I_F lies between max I_{FT} (2mA for FOD410 and FOD4108 and 1.3mA for FOD4116 and FOD4118 and the absolute max I_F (60mA).
- This is static dv/dt. See Figure 11 for test circuit. Commutating dv/dt is a function of the load-driving thyristor(s) only.
- Isolation voltage, V_{ISO}, is an internal device dielectric breakdown rating. For this test, Pins 1, 2 and 3 are common, and Pins 4, 5 and 6 are common.

Typical Application

Typical circuit for use when hot line switching is required. In this circuit the "hot" side of the line is switched and the load connected to the cold or neutral side. The load may be connected to either the neutral or hot line.

R_{in} is calculated so that I_F is equal to the rated I_{FT} of the part, 2mA for FOD410 and FOD4108, 1.3mA for FOD4116 and FOD4118. The 39Ω resistor and 0.01μF capacitor are for snubbing of the triac and may or may not be necessary depending upon the particular triac and load use.

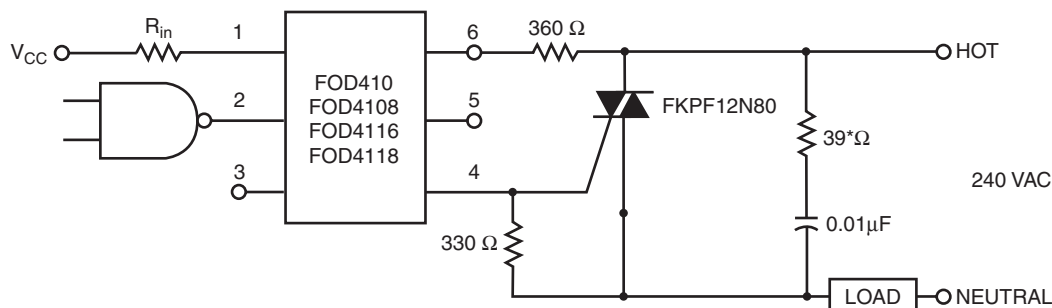

* For highly inductive loads (power factor < 0.5), change this value to 360 ohms.

Figure 1. Hot-Line Switching Application Circuit

Typical Performance Curves

Figure 2. Forward Voltage (V_F) vs. Forward Current (I_F)

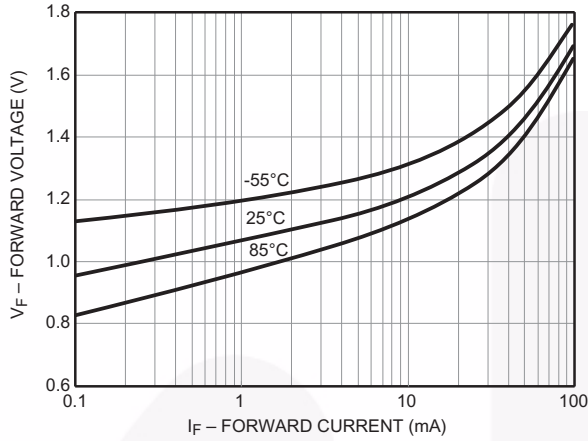

Figure 3. Normalized LED Trigger Current (I_{FT}) vs. Ambient Temperature (T_A)

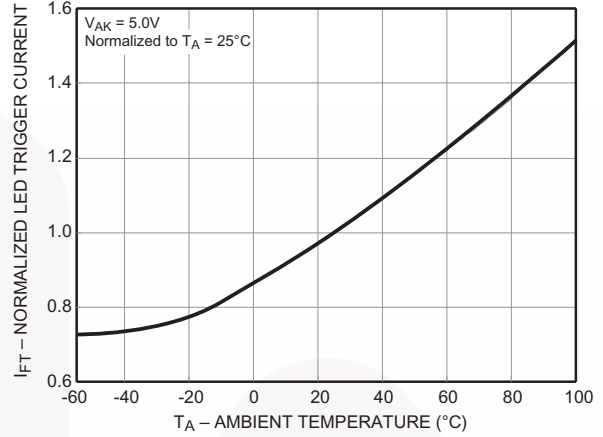

Figure 4. Peak LED Current vs. Duty Factor, Tau

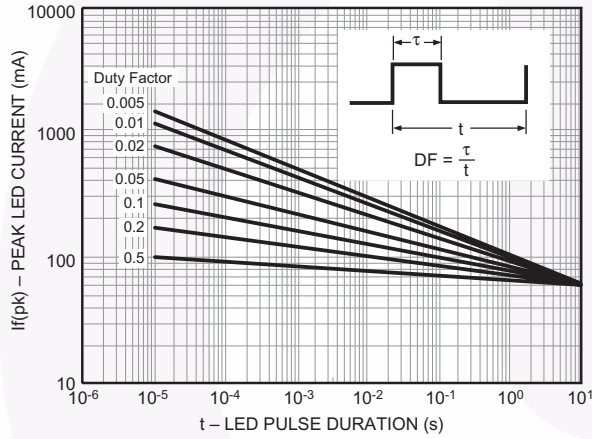

Figure 5. Trigger Delay Time

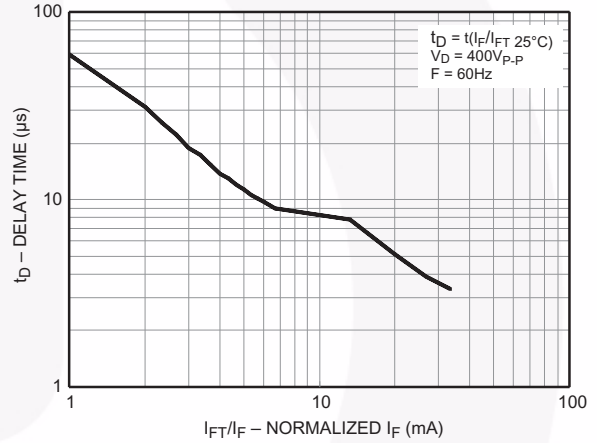

Figure 6. Pulse Trigger Current

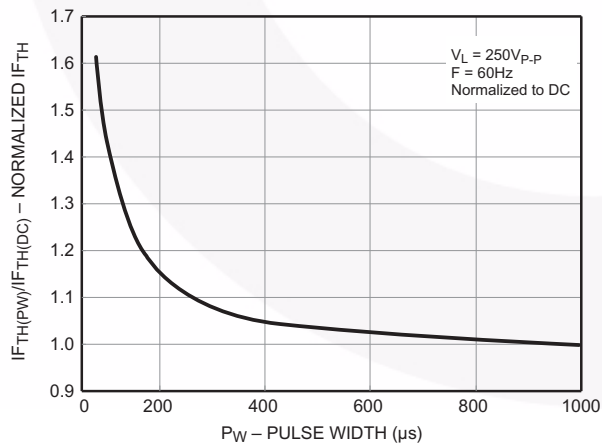
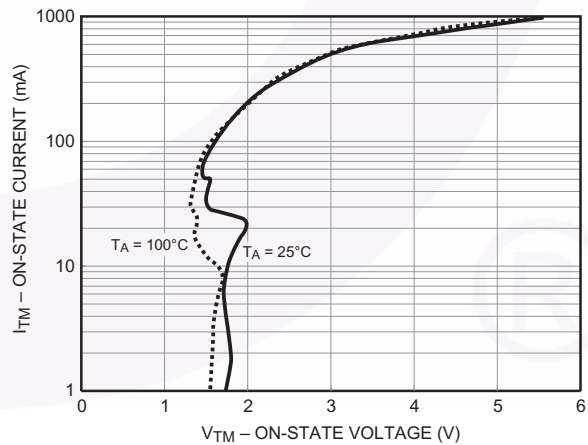

Figure 7. On-State Voltage (V_{TM}) vs. On-State Current (I_{TM})



Typical Performance Curves (Continued)

Figure 8. Normalized Holding Current (I_H) vs. Ambient Temperature (T_A)

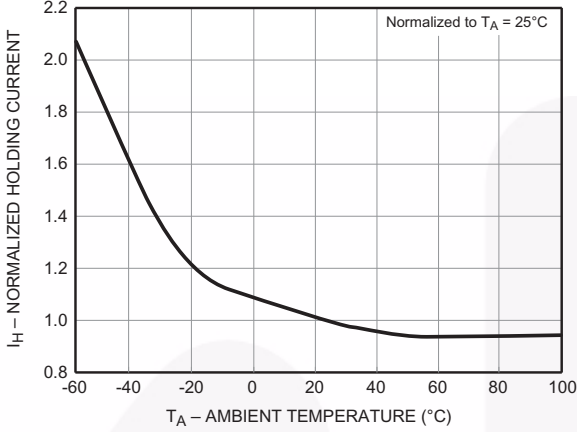

Figure 9. Off-State Current (I_{BD}) vs. Ambient Temperature (T_A)

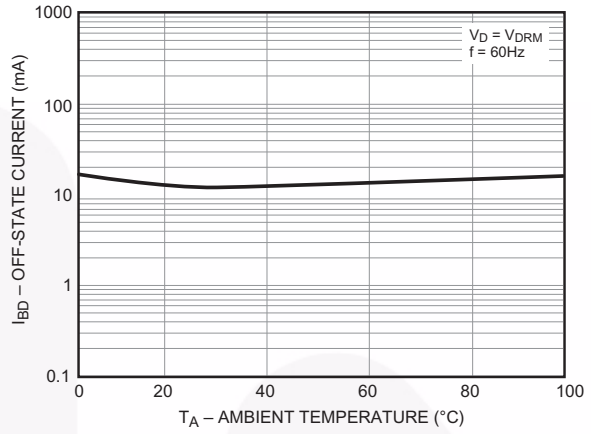

Figure 10. Normalized Inhibit Voltage (V_{INH}) vs. Ambient Temperature (T_A)

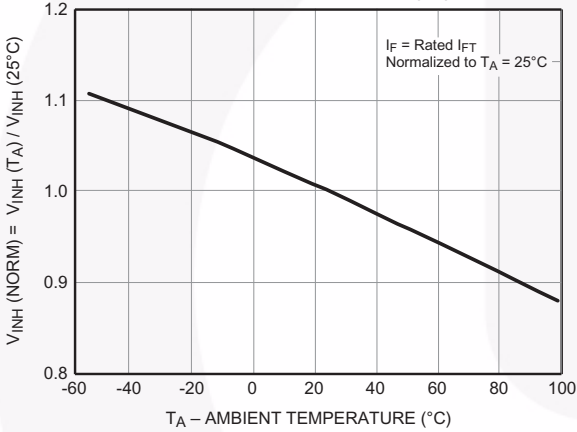

Figure 11. Normalized Leakage in Inhibit State (I_{DRM}) vs. Ambient Temperature (T_A)

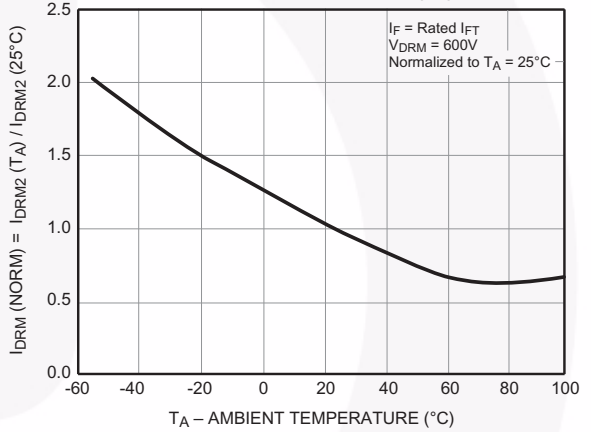
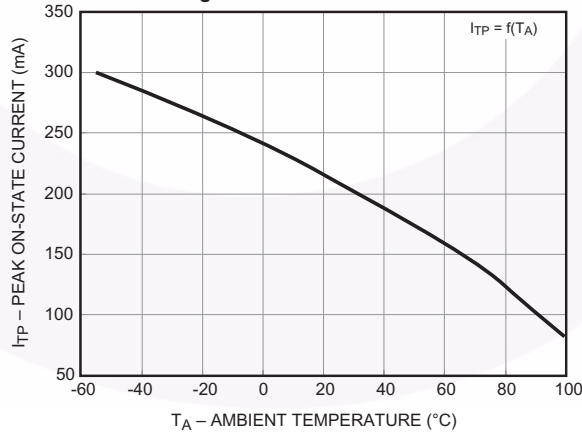
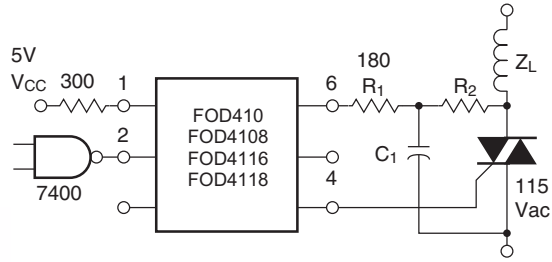

Figure 12. Current Reduction





NOTE: Circuit supplies 25mA drive to gate of triac at $V_{in} = 25V$ and $T_A < 70^\circ C$

TRIAC		
I_{GT}	R_2	C
15 mA	2400	0.1
30 mA	1200	0.2
50 mA	800	0.3

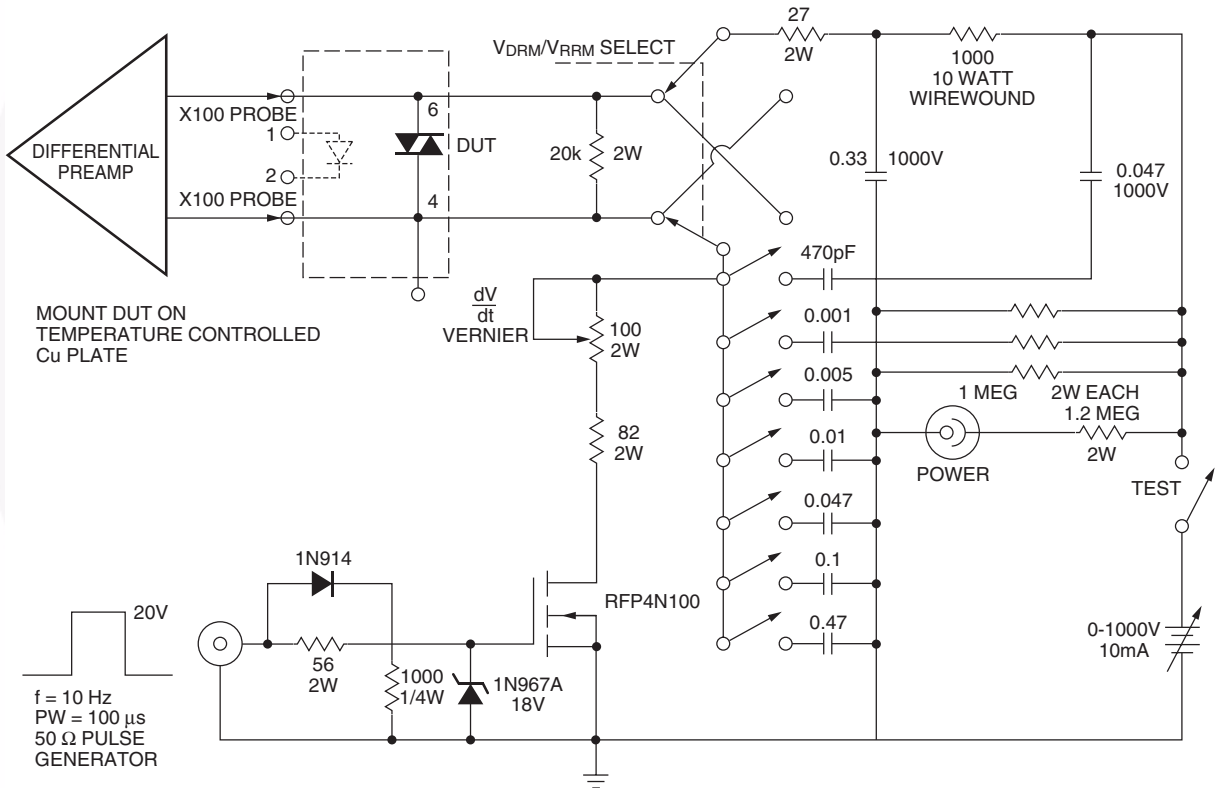

ALL COMPONENTS ARE NON-INDUCTIVE UNLESS SHOWN

Figure 11. Circuit for Static $\frac{dv}{dt}$ Measurement of Power Thyristors

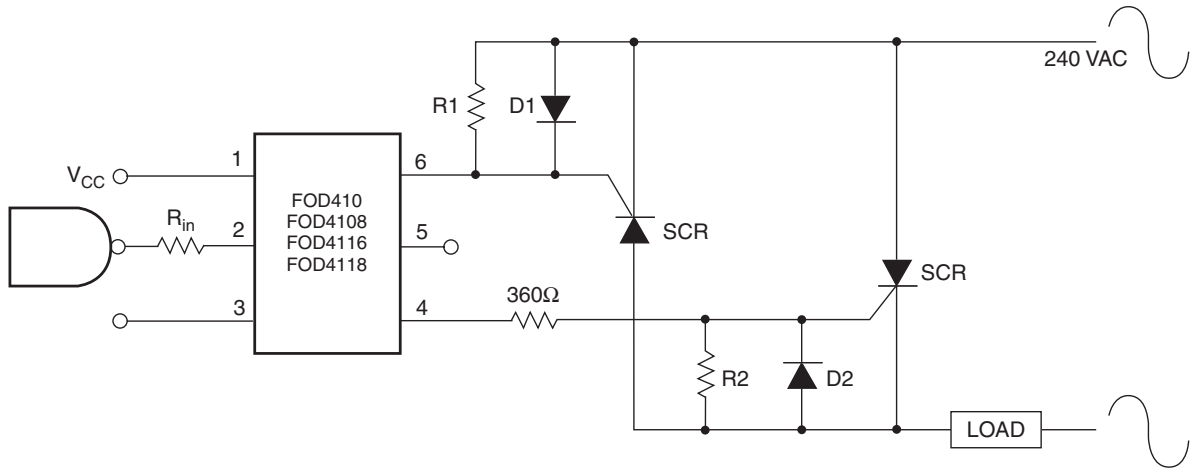

Figure 12. Inverse-Parallel SCR Driver Circuit

Suggested method of firing two, back-to-back SCR's with a Fairchild triac driver. Diodes can be 1N4001; resistors, R1 and R2, are optional 330Ω.

Note: This optoisolator should not be used to drive a load directly. It is intended to be a discrete triac driver device only.

Package Dimensions

Through Hole

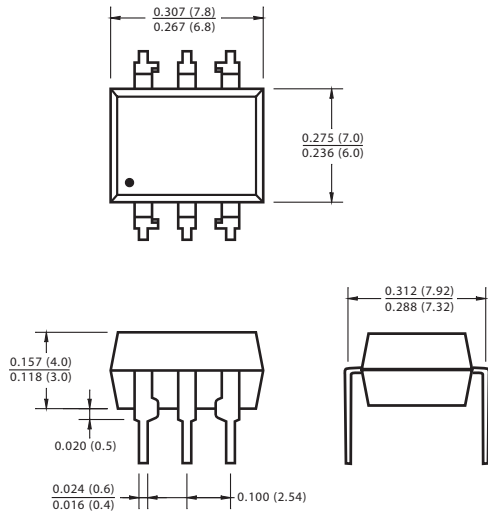

Surface Mount

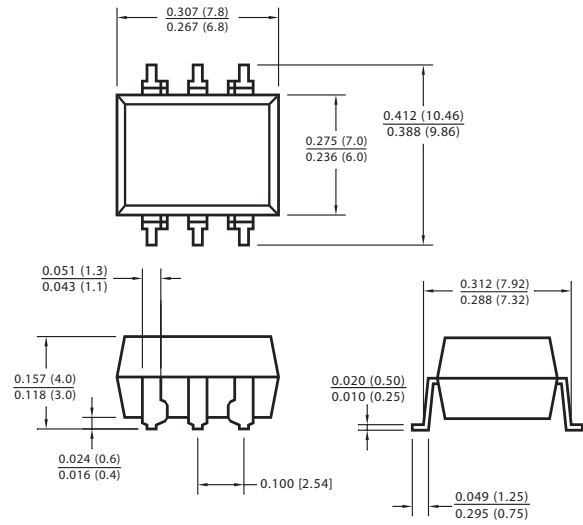

0.4" Lead Spacing

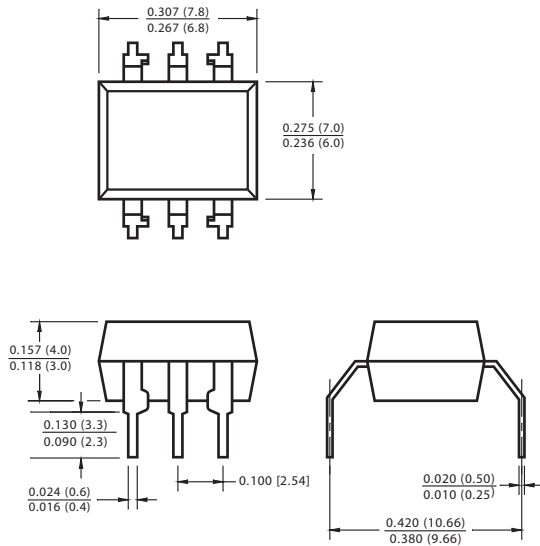

Recommended Pad Layout for Surface Mount Leadforms

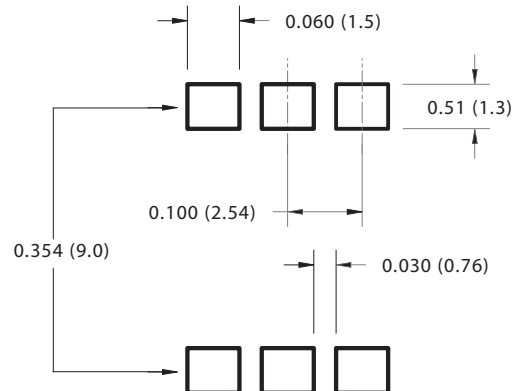

Note:

All dimensions are in inches (millimeters)



Ordering Information

Option	Order Entry Identifier (example)	Description
None	FOD410	Standard Through Hole Device
S	FOD410S	Surface Mount Lead Bend
SD	FOD410SD	Surface Mount; Tape and reel
T	FOD410T	0.4" Lead Spacing
V	FOD410V	IEC60747-5-2 certification
TV	FOD410TV	IEC60747-5-2 certification, 0.4" Lead Spacing
SV	FOD410SV	IEC60747-5-2 certification, Surface Mount
SDV	FOD410SDV	IEC60747-5-2 certification, Surface Mount, Tape & Reel

Marking Information

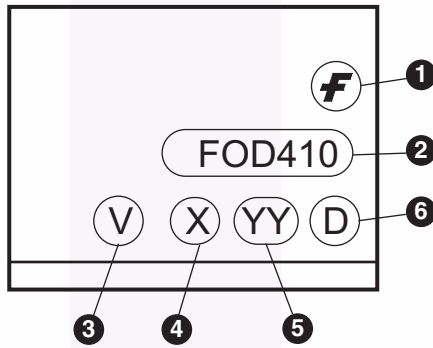

Definitions	
1	Fairchild logo
2	Device number
3	VDE mark indicates IEC60747-5-2 certified (Note: Only appears on parts ordered with VDE option – See order entry table)
4	One digit year code, e.g., '7'
5	Two digit work week ranging from '01' to '53'
6	Assembly package code

Carrier Tape Specifications

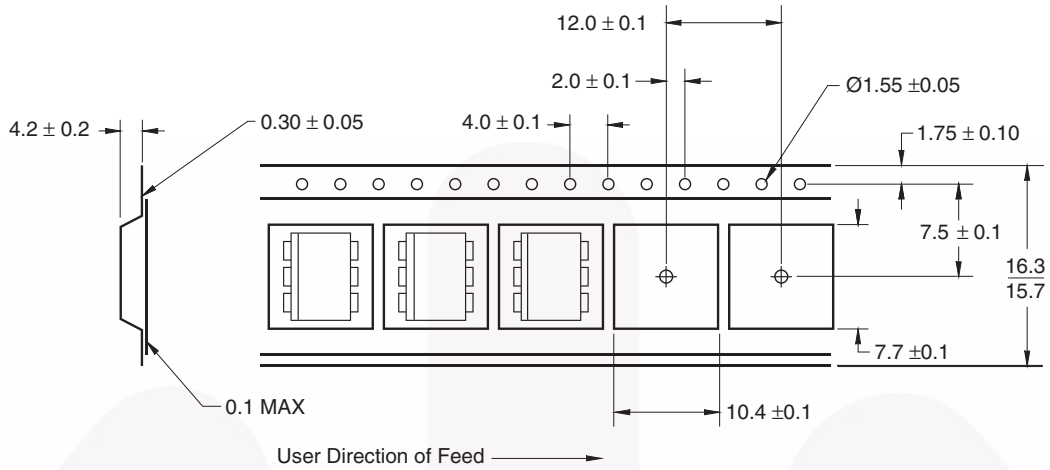

Note:
All dimensions are in inches (millimeters).

Reflow Profile

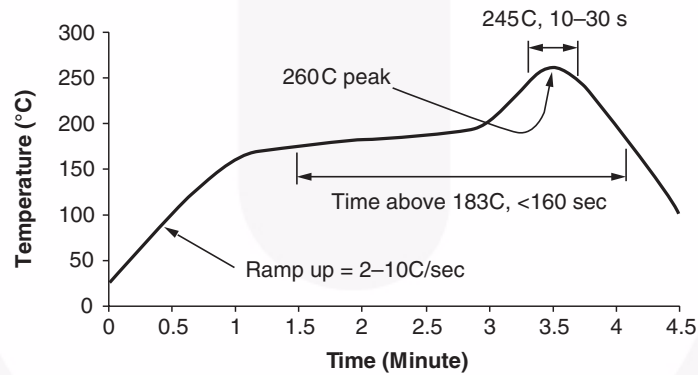



- Peak reflow temperature: 260C (package surface temperature)
- Time of temperature higher than 183C for 160 seconds or less
- One time soldering reflow is recommended



TRADEMARKS

The following includes registered and unregistered trademarks and service marks, owned by Fairchild Semiconductor and/or its global subsidiaries, and is not intended to be an exhaustive list of all such trademarks.

ACEx [®]	FPS [™]	PDP-SPM [™]	SupreMOS [™]
Build it Now [™]	FRFET [®]	Power220 [®]	SyncFET [™]
CorePLUS [™]	Global Power Resource SM	POWEREDGE [®]	SYSTEM [®]
CROSSVOLT [™]	Green FPS [™]	Power-SPM [™]	GENERAL [®]
CTL [™]	Green FPS [™] e-Series [™]	PowerTrench [®]	The Power Franchise [®]
Current Transfer Logic [™]	GTO [™]	Programmable Active Droop [™]	power [®]
EcoSPARK [®]	i-Lo [™]	QFET [®]	the franchise
EZSWITCH [™] *	IntelliMAX [™]	QS [™]	TinyBoost [™]
 ™	ISOPLANAR [™]	QT Optoelectronics [™]	TinyBuck [™]
 ™	MegaBuck [™]	Quiet Series [™]	TinyLogic [®]
Fairchild [®]	MICROCOUPLER [™]	RapidConfigure [™]	TINYOPTO [™]
Fairchild Semiconductor [®]	MicroFET [™]	SMART START [™]	TinyPower [™]
FACT Quiet Series [™]	MicroPak [™]	SPM [®]	TinyPWM [™]
FACT [®]	MillerDrive [™]	STEALTH [™]	TinyWire [™]
FAST [®]	Motion-SPM [™]	SuperFET [™]	μSerDes [™]
FastvCore [™]	OPTOLOGIC [®]	SuperSOT [™] 3	UHC [®]
FlashWriter [®] *	OPTOPLANAR [®]	SuperSOT [™] 6	Ultra FRFET [™]
		SuperSOT [™] 8	UniFET [™]
			VCS [™]

* EZSWITCH[™] and FlashWriter[®] are trademarks of System General Corporation, used under license by Fairchild Semiconductor.

DISCLAIMER

FAIRCHILD SEMICONDUCTOR RESERVES THE RIGHT TO MAKE CHANGES WITHOUT FURTHER NOTICE TO ANY PRODUCTS HEREIN TO IMPROVE RELIABILITY, FUNCTION, OR DESIGN. FAIRCHILD DOES NOT ASSUME ANY LIABILITY ARISING OUT OF THE APPLICATION OR USE OF ANY PRODUCT OR CIRCUIT DESCRIBED HEREIN; NEITHER DOES IT CONVEY ANY LICENSE UNDER ITS PATENT RIGHTS, NOR THE RIGHTS OF OTHERS. THESE SPECIFICATIONS DO NOT EXPAND THE TERMS OF FAIRCHILD'S WORLDWIDE TERMS AND CONDITIONS, SPECIFICALLY THE WARRANTY THEREIN, WHICH COVERS THESE PRODUCTS.

LIFE SUPPORT POLICY

FAIRCHILD'S PRODUCTS ARE NOT AUTHORIZED FOR USE AS CRITICAL COMPONENTS IN LIFE SUPPORT DEVICES OR SYSTEMS WITHOUT THE EXPRESS WRITTEN APPROVAL OF FAIRCHILD SEMICONDUCTOR CORPORATION.

As used herein:

- Life support devices or systems are devices or systems which, (a) are intended for surgical implant into the body or (b) support or sustain life, and (c) whose failure to perform when properly used in accordance with instructions for use provided in the labeling, can be reasonably expected to result in a significant injury of the user.
- A critical component in any component of a life support, device, or system whose failure to perform can be reasonably expected to cause the failure of the life support device or system, or to affect its safety or effectiveness.

PRODUCT STATUS DEFINITIONS

Definition of Terms

Datasheet Identification	Product Status	Definition
Advance Information	Formative or In Design	This datasheet contains the design specifications for product development. Specifications may change in any manner without notice.
Preliminary	First Production	This datasheet contains preliminary data; supplementary data will be published at a later date. Fairchild Semiconductor reserves the right to make changes at any time without notice to improve design.
No Identification Needed	Full Production	This datasheet contains final specifications. Fairchild Semiconductor reserves the right to make changes at any time without notice to improve the design.
Obsolete	Not In Production	This datasheet contains specifications on a product that has been discontinued by Fairchild Semiconductor. The datasheet is printed for reference information only.

Rev. I33