

100 V field-effect rectifier diode

Datasheet - production data

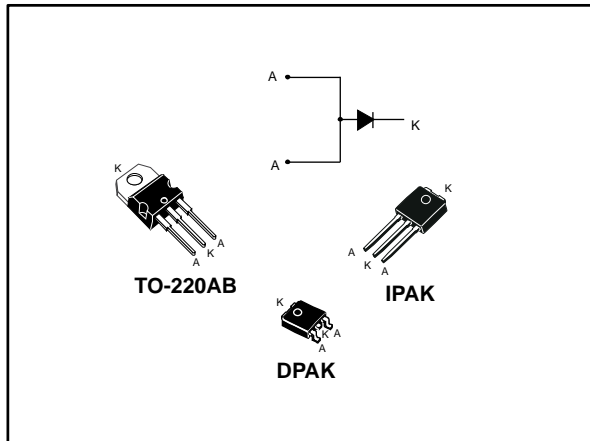

Description

The device is based on a proprietary technology that achieves the best in class V_F/I_R trade-off for a given silicon surface. This 100 V rectifier has been optimized for use in confined applications where both efficiency and thermal performance are key. With a lower dependency of leakage current (I_R) and forward voltage (V_F) in function of temperature, the thermal runaway risk is reduced. It is highly recommended to be used in adapters and chargers.

Table 1: Device summary

Symbol	Value
$I_{F(AV)}$	30 A
V_{RRM}	100 V
V_F (max.)	0.405 V
I_R (max.)	130 μ A
T_j (max.)	175 °C

Features

- ST advanced rectifier process
- Stable leakage current over reverse voltage
- Reduced leakage current
- Low forward voltage drop
- High frequency operation

1 Characteristics

Table 2: Absolute ratings (limiting values at 25 °C, unless otherwise specified, with anode terminals short circuited)

Symbol	Parameter		Value	Unit
V _{RRM}	Repetitive peak reverse voltage		100	V
I _{F(RMS)}	Forward rms current		45	A
I _{F(AV)}	Average forward current $\delta = 0.5$, square wave	T _C = 145 °C	30	A
I _{FSM}	Surge non repetitive forward current	t _p = 10 ms sinusoidal, DPAK/IPAK	150	A
		t _p = 10 ms sinusoidal, TO-220AB	250	
T _{stg}	Storage temperature range		-65 to +175	°C
T _j	Maximum operating junction temperature ⁽¹⁾		+175	°C

Notes:

⁽¹⁾(dP_{tot}/dT_j) < (1/R_{th(j-a)}) condition to avoid thermal runaway for a diode on its own heatsink.

Table 3: Thermal resistance parameters

Symbol	Parameter	Value	Unit
R _{th(j-c)}	Junction to case	0.9	°C/W

Table 4: Static electrical characteristics with anode terminals short circuited

Symbol	Parameter	Test conditions		Min.	Typ.	Max.	Unit
		T _j	V _R				
I _R ⁽¹⁾	Reverse leakage current	T _j = 25 °C	V _R = V _{RRM}	-		130	μA
		T _j = 125 °C		-	8	16	mA
		T _j = 125 °C	V _R = 70 V	-	4	7	
V _F ⁽²⁾	Forward voltage drop	T _j = 25 °C	I _F = 3 A	-	0.390	0.440	V
		T _j = 125 °C		-	0.350	0.405	
		T _j = 25 °C	I _F = 5 A	-	0.440	0.495	
		T _j = 125 °C		-	0.415	0.470	
		T _j = 25 °C	I _F = 10 A	-	0.550	0.620	
		T _j = 125 °C		-	0.530	0.585	
		T _j = 125 °C		I _F = 30 A	-	0.680	

Notes:

⁽¹⁾Pulse test: t_p = 5 ms, $\delta < 2\%$

⁽²⁾Pulse test: t_p = 380 μs, $\delta < 2\%$

To evaluate the conduction losses use the following equation:

$$P = 0.424 \times I_{F(AV)} + 0.0133 I_{F(RMS)}^2$$

1.1 Characteristics (curves)

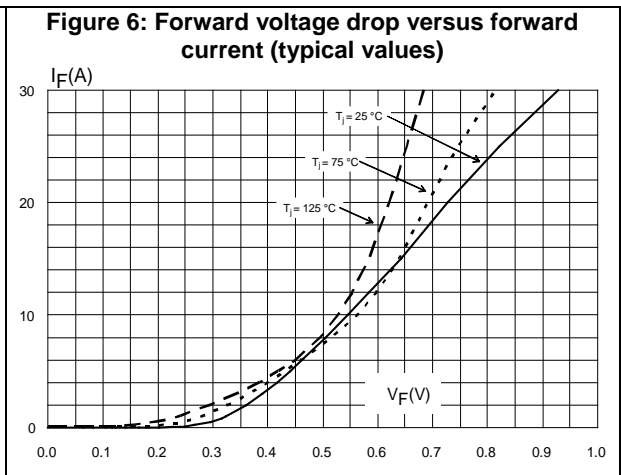
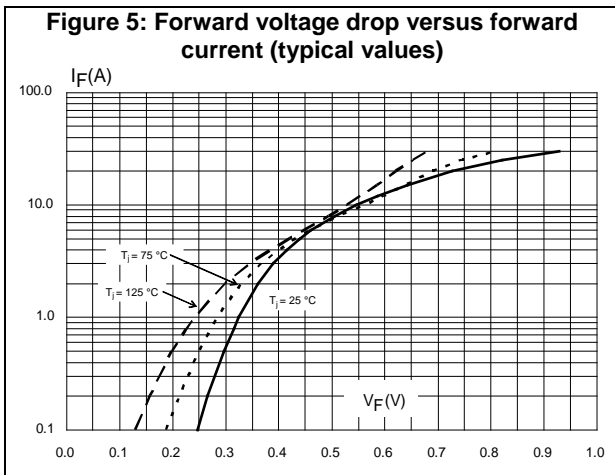
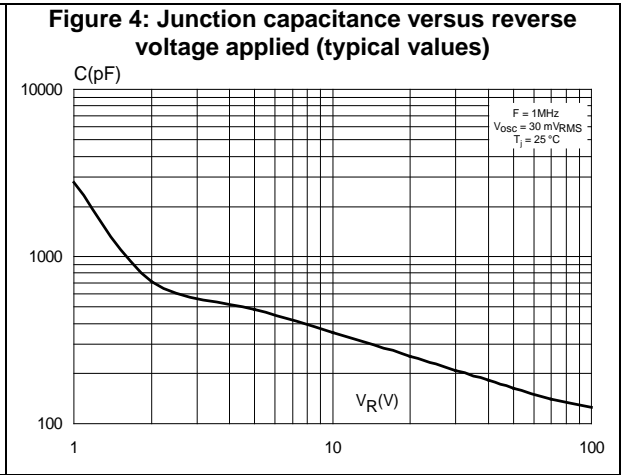
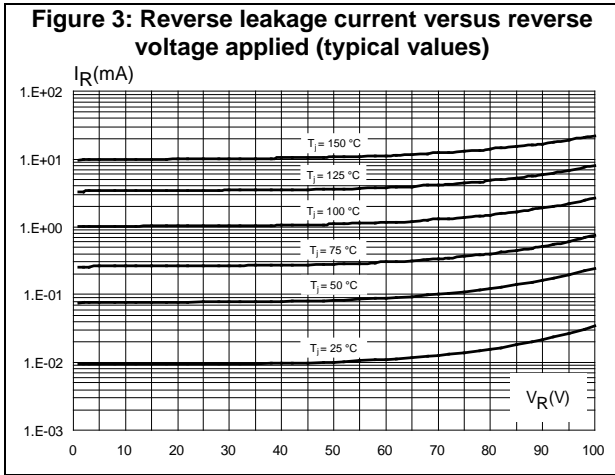
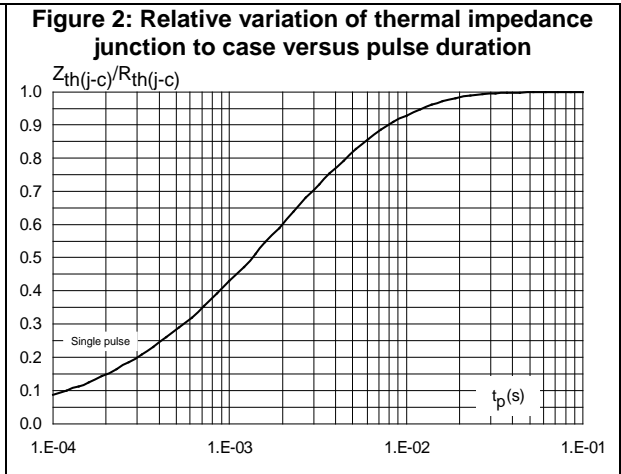
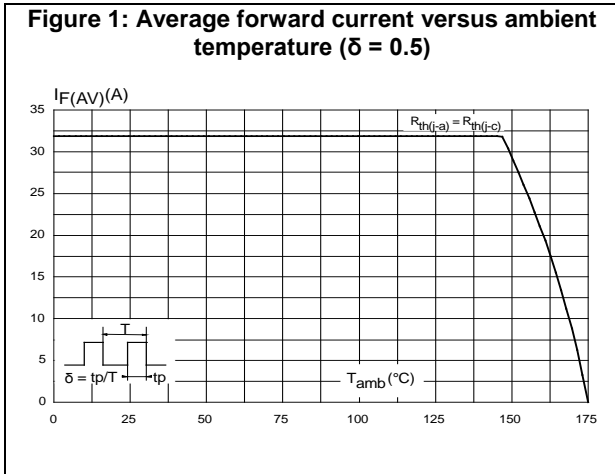
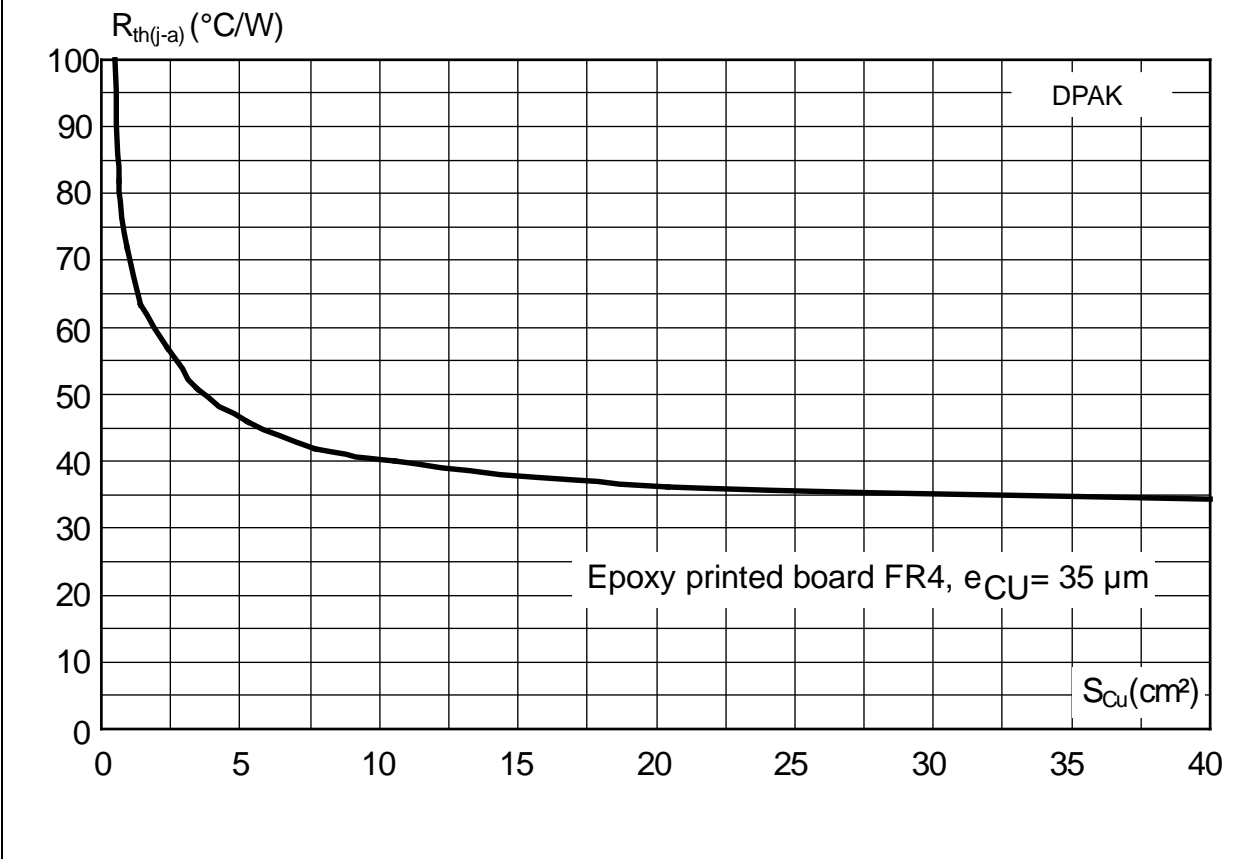

Figure 7: Thermal resistance junction to ambient versus copper surface under tab for DPAK (typical values)



2 Package information

In order to meet environmental requirements, ST offers these devices in different grades of ECOPACK® packages, depending on their level of environmental compliance. ECOPACK® specifications, grade definitions and product status are available at: www.st.com. ECOPACK® is an ST trademark.

- Cooling method: by conduction (C)
- Epoxy meets UL 94, V0
- Recommended torque value: 0.55 N·m (for TO-220AB)
- Maximum torque value: 0.6 N·m (for TO-220AB)

2.1 TO-220AB package information

Figure 8: TO-220AB package outline

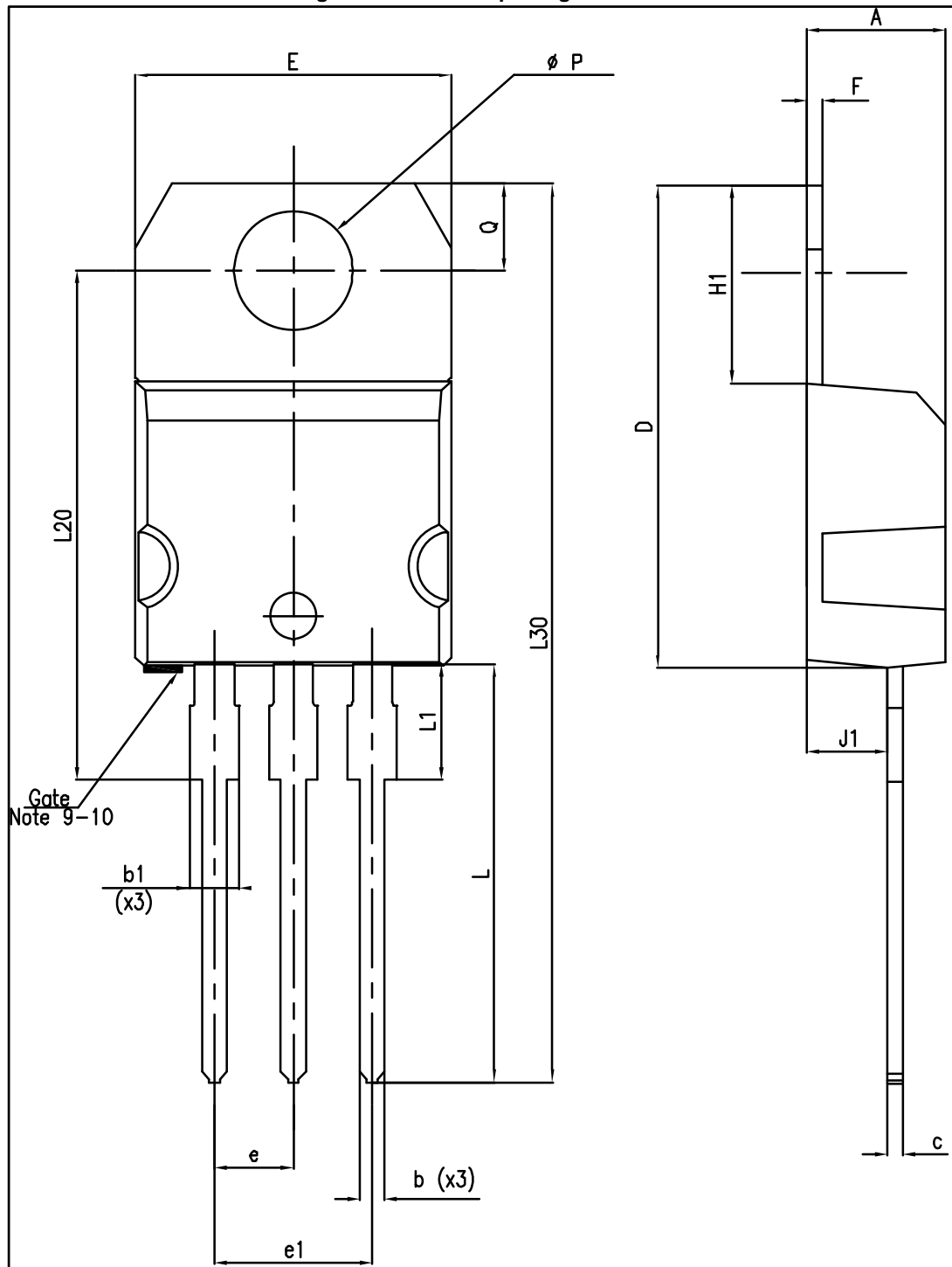
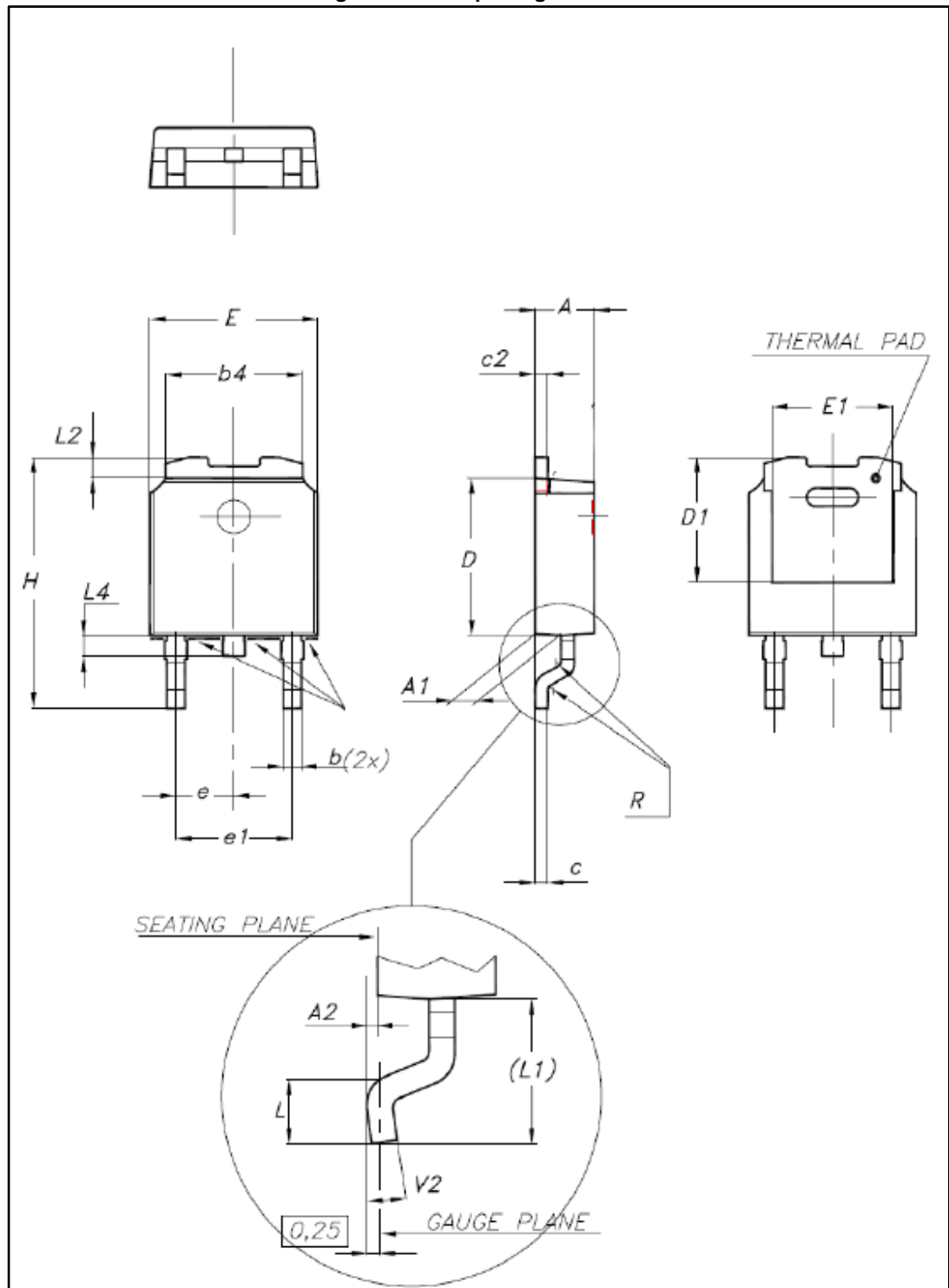

Table 5: TO-220AB package mechanical data

Ref.	Dimensions			
	Millimeters		Inches	
	Min.	Max.	Min.	Max.
A	4.40	4.60	0.173	0.181
b	0.61	0.88	0.024	0.035
b1	1.14	1.70	0.045	0.067
c	0.48	0.70	0.019	0.028
D	15.25	15.75	0.600	0.620
E	10.00	10.40	0.394	0.409
e	2.40	2.70	0.094	0.106
e1	4.95	5.15	0.195	0.203
F	0.51	0.60	0.020	0.024
J1	2.40	2.72	0.094	0.107
H1	6.20	6.60	0.244	0.256
L	13.00	14.00	0.512	0.551
L1	3.50	3.93	0.138	0.155
L20	16.40 typ.		0.646 typ.	
L30	28.90 typ.		1.138	
Ø P	3.75	3.85	0.148	0.156
Q	2.65	2.95	0.104	0.116

2.2 DPAK package information

Figure 9: DPAK package outline





This package drawing may slightly differ from the physical package. However, all the specified dimensions are guaranteed.

Table 6: DPAK package mechanical data

Ref.	Dimensions			
	Millimeters		Inches	
	Min.	Max.	Min.	Max.
A	2.18	2.40	0.085	0.094
A1	0.90	1.10	0.035	0.043
A2	0.03	0.23	0.001	0.009
b	0.64	0.90	0.025	0.035
b4	4.95	5.46	0.194	0.215
c	0.46	0.61	0.018	0.024
c2	0.46	0.60	0.018	0.023
D	5.97	6.22	0.235	0.244
D1	4.95	5.60	0.194	0.220
E	6.35	6.73	0.250	0.265
E1	4.32	5.50	0.170	0.216
e	2.286 typ.		0.090 typ.	
e1	4.40	4.70	0.173	0.185
H	9.35	10.40	0.368	0.409
L	1.0	1.78	0.039	0.070
L2		1.27		0.050
L4	0.60	1.02	0.023	0.040
V2	-8°	+8°	-8°	+8°

Figure 10: DPAK recommended footprint (dimensions in mm)

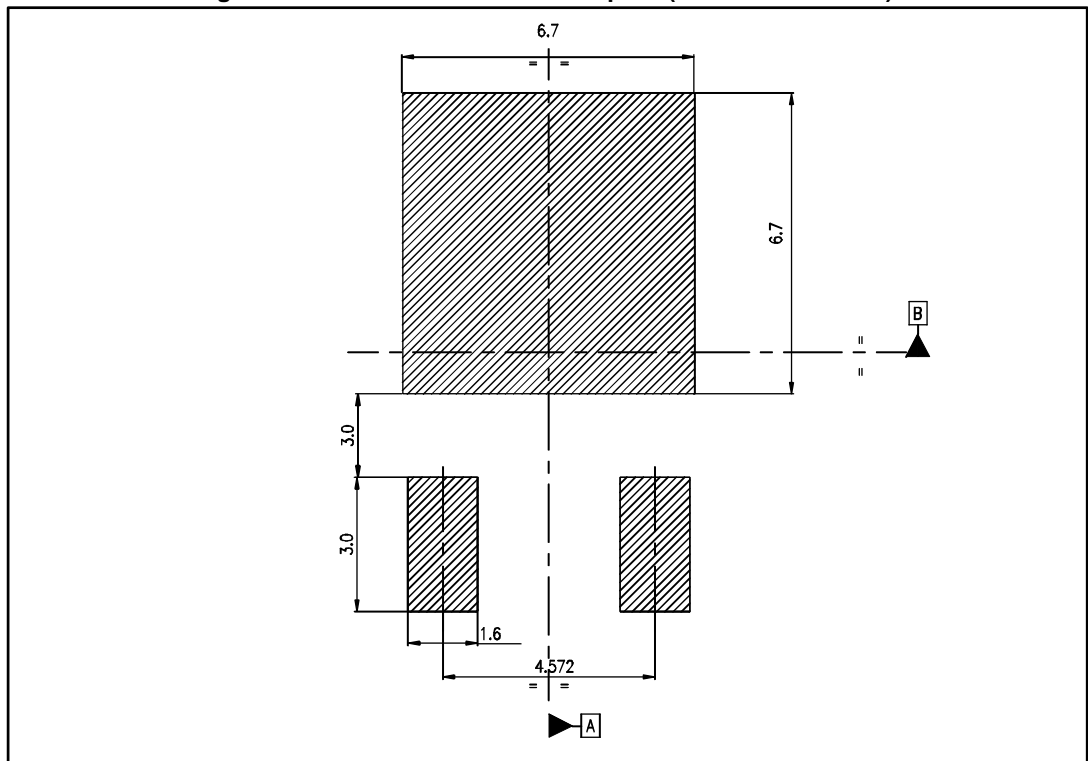

2.3 IPAK package information

Figure 11: IPAK package outline

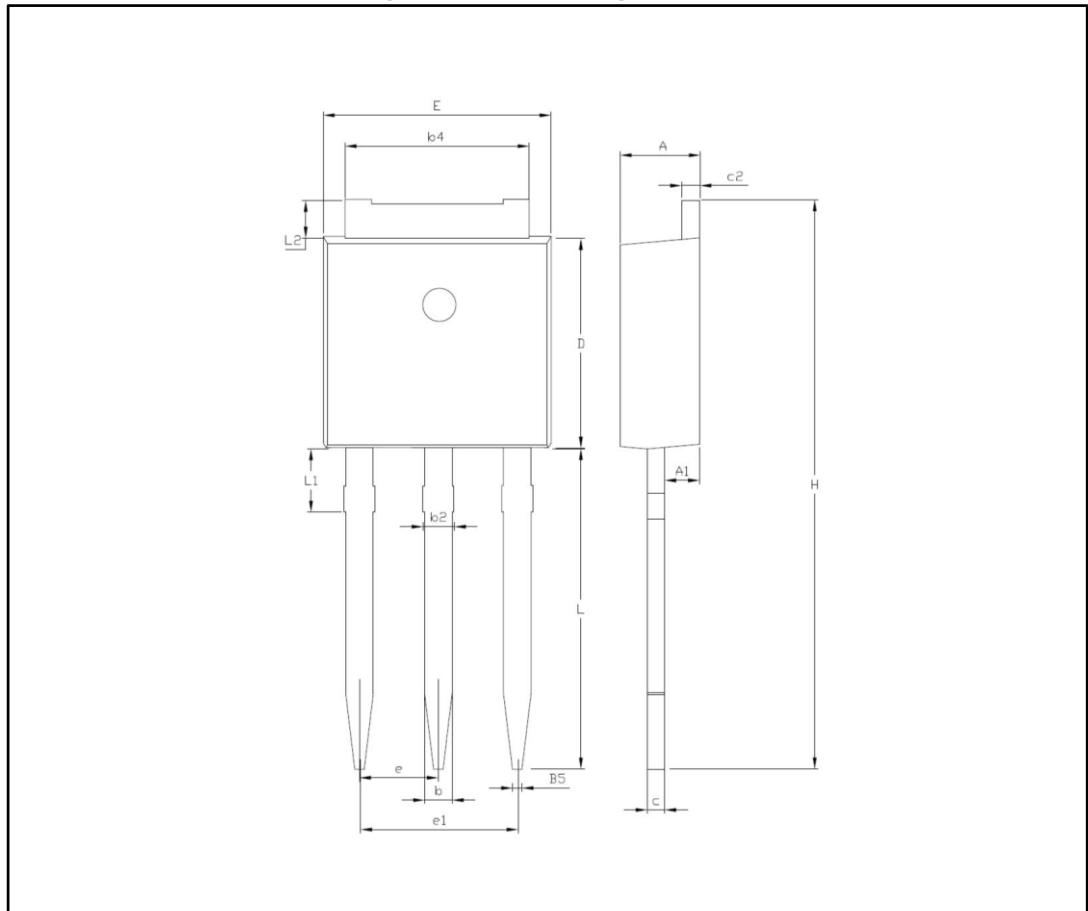

Table 7: IPAK package mechanical data

Ref.	Dimensions			
	Millimeters		Inches	
	Min.	Max.	Min.	Max.
A	2.20	2.40	0.087	0.094
A1	0.90	1.10	0.035	0.043
b	0.64	0.90	0.025	0.035
b2		0.95		0.037
b4	5.20	5.43	0.205	0.214
B5	0.30 typ.		0.012 typ.	
c	0.45	0.60	0.018	0.024
c2	0.46	0.60	0.018	0.024
D	6.00	6.20	0.236	0.244
E	6.40	6.65	0.252	0.261
e	2.28 typ.		typ.0.090	
e1	4.40	4.60	0.173	0.181
H	16.10 typ.		0.634 typ.	
L	9.0	9.60	0.354	0.378
L1	0.80	1.20	0.031	0.047
L2	0.80 typ.	1.25	0.031 typ.	0.049
V1	+10°		+10	

3 Ordering information

Table 8: Ordering information

Order code	Marking	Package	Weight	Base qty.	Delivery mode
FERD30H100STS	FD30H100STS	TO-220AB	1.38 g	50	Tube
FERD30H100SH	FD30 H100S	IPAK	0.32 g	75	Tube
FERD30H100SB-TR	FD30 H100S	DPAK	0.35 g	2500	Tape and reel

4 Revision history

Table 9: Document revision history

Date	Revision	Changes
07-Apr-2016	1	Initial release.

IMPORTANT NOTICE – PLEASE READ CAREFULLY

STMicroelectronics NV and its subsidiaries ("ST") reserve the right to make changes, corrections, enhancements, modifications, and improvements to ST products and/or to this document at any time without notice. Purchasers should obtain the latest relevant information on ST products before placing orders. ST products are sold pursuant to ST's terms and conditions of sale in place at the time of order acknowledgement.

Purchasers are solely responsible for the choice, selection, and use of ST products and ST assumes no liability for application assistance or the design of Purchasers' products.

No license, express or implied, to any intellectual property right is granted by ST herein.

Resale of ST products with provisions different from the information set forth herein shall void any warranty granted by ST for such product.

ST and the ST logo are trademarks of ST. All other product or service names are the property of their respective owners.

Information in this document supersedes and replaces information previously supplied in any prior versions of this document.

© 2016 STMicroelectronics – All rights reserved