

isc N-Channel MOSFET Transistor

FCH041N60F

• FEATURES

- With TO-247 packaging
- With low gate drive requirements
- Easy to drive
- 100% avalanche tested
- Minimum Lot-to-Lot variations for robust device performance and reliable operation

• APPLICATIONS

- Switching applications

• ABSOLUTE MAXIMUM RATINGS(T<sub>a</sub>=25°C)

SYMBOL	PARAMETER	VALUE	UNIT
V <sub>DSS</sub>	Drain-Source Voltage	600	V
V <sub>GSS</sub>	Gate-Source Voltage	±20	V
I <sub>D</sub>	Drain Current-Continuous@T <sub>c</sub> =25°C T <sub>c</sub> =100°C	76 48.1	A
I <sub>DM</sub>	Drain Current-Single Pulsed	228	A
P <sub>D</sub>	Total Dissipation	595	W
T <sub>j</sub>	Operating Junction Temperature	-55~150	°C
T <sub>stg</sub>	Storage Temperature	-55~150	°C

• THERMAL CHARACTERISTICS

SYMBOL	PARAMETER	MAX	UNIT
R <sub>th(ch-c)</sub>	Channel-to-case thermal resistance	0.21	°C/W

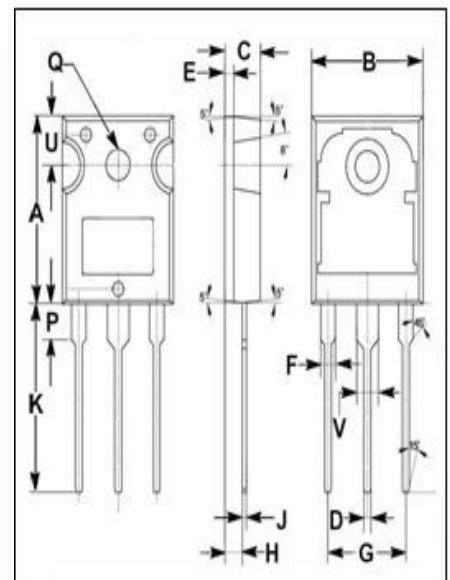
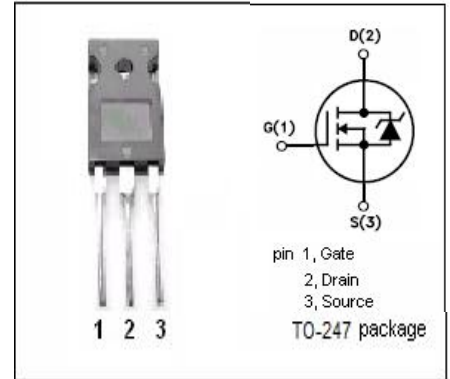

DIM	mm	
	MIN	MAX
A	19.80	20.20
B	15.40	15.80
C	4.90	5.10
D	0.90	1.10
E	1.40	1.60
F	1.90	2.10
G	10.80	11.00
H	2.40	2.60
J	0.50	0.70
K	19.50	20.50
P	3.90	4.10
Q	3.30	3.50
U	5.20	5.40
V	2.90	3.10

**isc N-Channel MOSFET Transistor**

**FCH041N60F**

**ELECTRICAL CHARACTERISTICS**

T<sub>c</sub>=25°C unless otherwise specified

SYMBOL	PARAMETER	CONDITIONS	MIN	TYP	MAX	UNIT
BV <sub>DSS</sub>	Drain-Source Breakdown Voltage	V <sub>GS</sub> =0V; I <sub>D</sub> = 10mA	600			V
V <sub>GS(th)</sub>	Gate Threshold Voltage	V <sub>DS</sub> =V <sub>GS</sub> ; I <sub>D</sub> =0.25mA	3.0		5.0	V
R <sub>DS(on)</sub>	Drain-Source On-Resistance	V <sub>GS</sub> = 10V; I <sub>D</sub> =38A		36	41	mΩ
I <sub>GSS</sub>	Gate-Source Leakage Current	V <sub>GS</sub> = ±20V; V <sub>DS</sub> = 0V			±0.1	μA
I <sub>DSS</sub>	Drain-Source Leakage Current	V <sub>DS</sub> = 480V; V <sub>GS</sub> = 0V; @T <sub>c</sub> =25°C V <sub>DS</sub> = 480V; V <sub>GS</sub> = 0V; T <sub>c</sub> =125°C			1 10	μA
V <sub>SDF</sub>	Diode forward voltage	I <sub>SD</sub> =38A, V <sub>GS</sub> = 0 V			1.2	V