

# ESD8501V5

## Transient Voltage Suppressors

### Features

- Protection for the following IEC Standards:  
IEC61000-4-2 Level 4:  $\pm 30$  kV Contact Discharge  
IEC61000-4-5 (Lightning) 70 A (8/20  $\mu$ s)
- These Devices are Pb-Free, Halogen Free/BFR Free and are RoHS Compliant

### MAXIMUM RATINGS

| Rating   | Symbol         | Value                | Unit         |
|--|----------------|----------------------|--------------|
| IEC 61000-4-2 (ESD) Contact Air                                |                | $\pm 30$<br>$\pm 30$ | kV           |
| Operating Junction and Storage Temperature Range               | $T_J, T_{stg}$ | -65 to +150          | $^{\circ}$ C |
| Maximum Peak Pulse Current 8/20 $\mu$ s @ $T_A = 25^{\circ}$ C | $I_{PP}$       | 70                   | A            |

Stresses exceeding those listed in the Maximum Ratings table may damage the device. If any of these limits are exceeded, device functionality should not be assumed, damage may occur and reliability may be affected.



**ON Semiconductor**<sup>®</sup>

<http://onsemi.com>

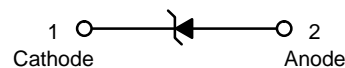

**UDFN2  
CASE 517CZ**

### MARKING DIAGRAM



A = Specific Device Code  
M = Date Code

### ORDERING INFORMATION

| Device         | Package            | Shipping <sup>†</sup> |
|----------------|--------------------|-----------------------|
| ESD8501V5MUT5G | UDFN2<br>(Pb-Free) | 8000 / Tape &<br>Reel |

<sup>†</sup>For information on tape and reel specifications, including part orientation and tape sizes, please refer to our Tape and Reel Packaging Specifications Brochure, BRD8011/D.

# ESD8501V5

## ELECTRICAL CHARACTERISTICS

( $T_A = 25^\circ\text{C}$  unless otherwise noted)

| Symbol    | Parameter                                   |
|-----------|---|
| $I_{PP}$  | Maximum Reverse Peak Pulse Current          |
| $V_C$     | Clamping Voltage @ $I_{PP}$                 |
| $V_{RWM}$ | Working Peak Reverse Voltage                |
| $I_R$     | Maximum Reverse Leakage Current @ $V_{RWM}$ |
| $V_{BR}$  | Breakdown Voltage @ $I_T$                   |
| $I_T$     | Test Current                                |

\*See Application Note AND8308/D for detailed explanations of datasheet parameters.

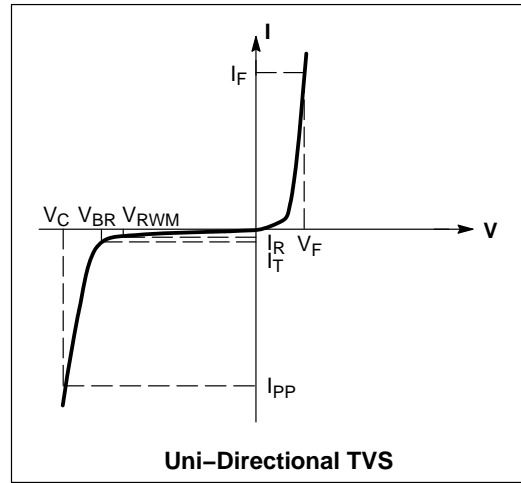

Uni-Directional TVS

## ELECTRICAL CHARACTERISTICS ( $T_A = 25^\circ\text{C}$ unless otherwise specified)

| Parameter                  | Symbol    | Conditions  | Min | Typ  | Max  | Unit          |
|----------------------------|-----------|---|-----|------|------|---------------|
| Reverse Working Voltage    | $V_{RWM}$ |   |     |      | 5.0  | V             |
| Breakdown Voltage (Note 1) | $V_{BR}$  | $I_T = 1 \text{ mA}$                                      | 6.0 | 7.0  | 9.0  | V             |
| Reverse Leakage Current    | $I_R$     | $V_{RWM} = 5 \text{ V}$                                   |     |      | 0.1  | $\mu\text{A}$ |
| Clamping Voltage (Note 2)  | $V_C$     | $I_{PP} = 1 \text{ A}$ , $t_p = 8 \times 20 \mu\text{s}$  |     |      | 7.5  | V             |
| Clamping Voltage (Note 2)  | $V_C$     | $I_{PP} = 35 \text{ A}$ , $t_p = 8 \times 20 \mu\text{s}$ |     |      | 9.5  | V             |
| Clamping Voltage (Note 2)  | $V_C$     | $I_{PP} = 70 \text{ A}$ , $t_p = 8 \times 20 \mu\text{s}$ |     |      | 11.5 | V             |
| Junction Capacitance       | $C_J$     | $V_R = 0 \text{ V}$ , $f = 1 \text{ MHz}$                 |     |      | 16   | pF            |
| Dynamic Resistance         | $R_{DYN}$ | TLP Pulse   |     | 0.04 |      | $\Omega$      |

Product parametric performance is indicated in the Electrical Characteristics for the listed test conditions, unless otherwise noted. Product performance may not be indicated by the Electrical Characteristics if operated under different conditions.

- Breakdown voltage is tested from pin 1 to 2 and pin 2 to 1.
- Non-repetitive current pulse at  $T_A = 25^\circ\text{C}$ , per IEC61000-4-5 waveform.

# ESD8501V5

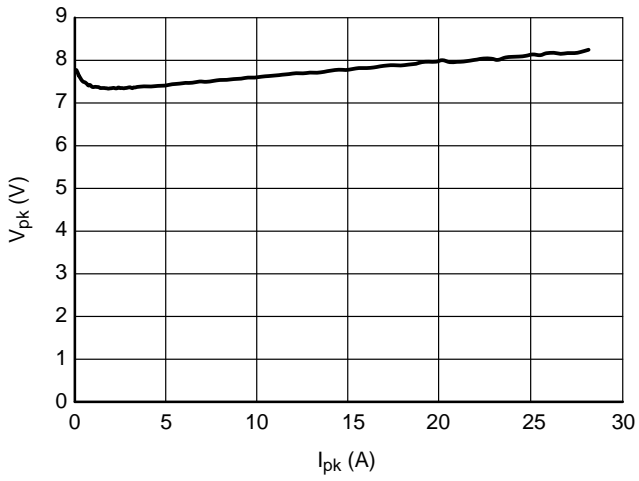

Figure 1. Positive TLP I-V Curve

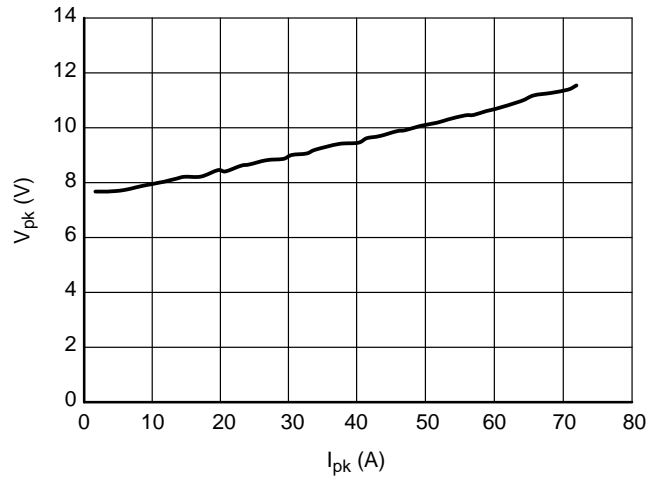

Figure 2. Clamping Voltage vs. Peak Pulse Current ( $t_p = 8/20 \mu s$ )

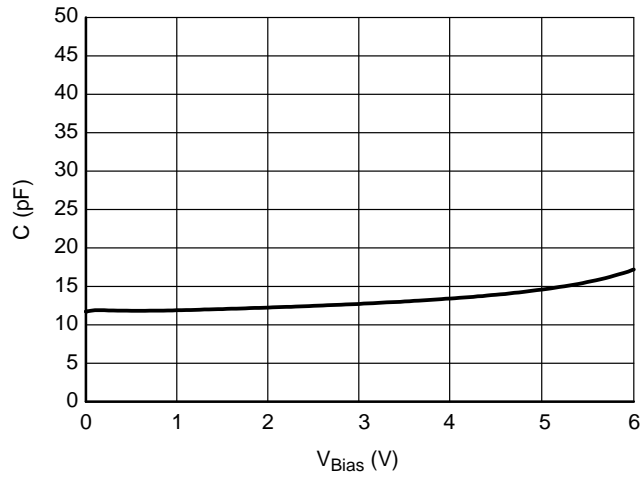
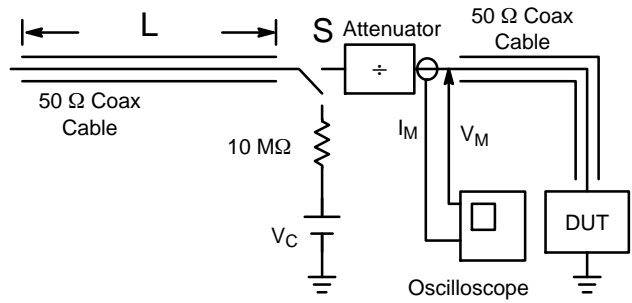

Figure 3. CV Characteristics

**Transmission Line Pulse (TLP) Measurement**

Transmission Line Pulse (TLP) provides current versus voltage (I–V) curves in which each data point is obtained from a 100 ns long rectangular pulse from a charged transmission line. A simplified schematic of a typical TLP system is shown in Figure 4. TLP I–V curves of ESD protection devices accurately demonstrate the product’s ESD capability because the 10s of amps current levels and under 100 ns time scale match those of an ESD event. This is illustrated in Figure 5 where an 8 kV IEC 61000–4–2 current waveform is compared with TLP current pulses at 8 A and 16 A. A TLP I–V curve shows the voltage at which the device turns on as well as how well the device clamps voltage over a range of current levels. For more information on TLP measurements and how to interpret them please refer to AND9007/D.



**Figure 4. Simplified Schematic of a Typical TLP System**

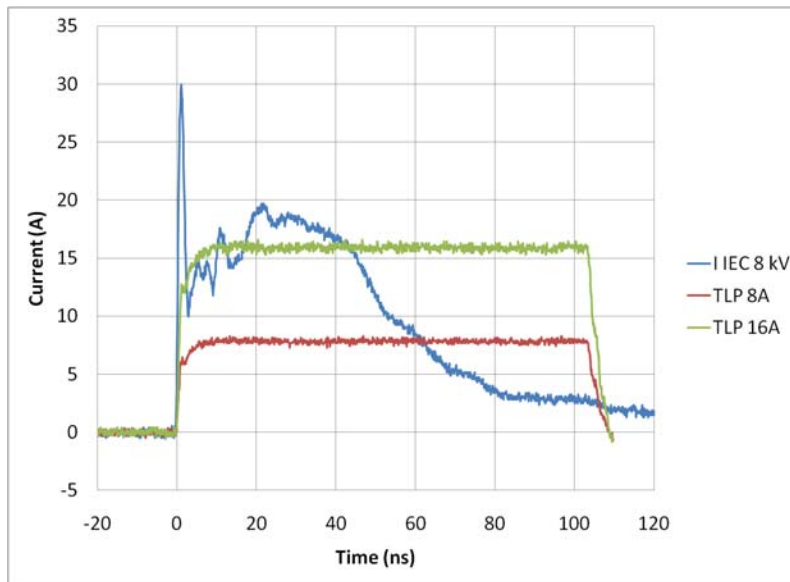

**Figure 5. Comparison Between 8 kV IEC 61000–4–2 and 8 A and 16 A TLP Waveforms**

# ESD8501V5

## IEC 61000-4-2 Spec.

| Level | Test Voltage (kV) | First Peak Current (A) | Current at 30 ns (A) | Current at 60 ns (A) |
|-------|-------------------|------------------------|----------------------|----------------------|
| 1     | 2                 | 7.5                    | 4                    | 2                    |
| 2     | 4                 | 15                     | 8                    | 4                    |
| 3     | 6                 | 22.5                   | 12                   | 6                    |
| 4     | 8                 | 30                     | 16                   | 8                    |



Figure 6. IEC61000-4-2 Spec

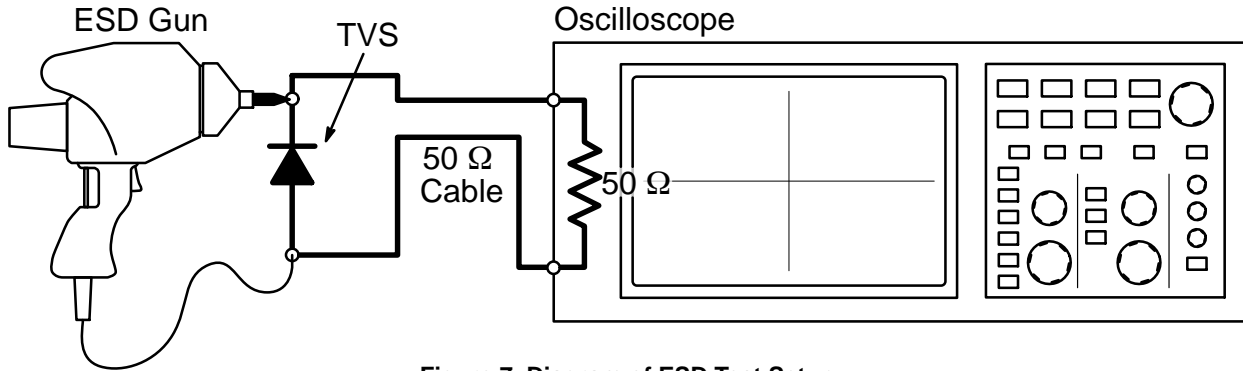

Figure 7. Diagram of ESD Test Setup

### ESD Voltage Clamping

For sensitive circuit elements it is important to limit the voltage that an IC will be exposed to during an ESD event to as low a voltage as possible. The ESD clamping voltage is the voltage drop across the ESD protection diode during an ESD event per the IEC61000-4-2 waveform. Since the IEC61000-4-2 was written as a pass/fail spec for larger systems such as cell phones or laptop computers it is not clearly defined in the spec how to specify a clamping voltage

at the device level. ON Semiconductor has developed a way to examine the entire voltage waveform across the ESD protection diode over the time domain of an ESD pulse in the form of an oscilloscope screenshot, which can be found on the datasheets for all ESD protection diodes. For more information on how ON Semiconductor creates these screenshots and how to interpret them please refer to AND8307/D.

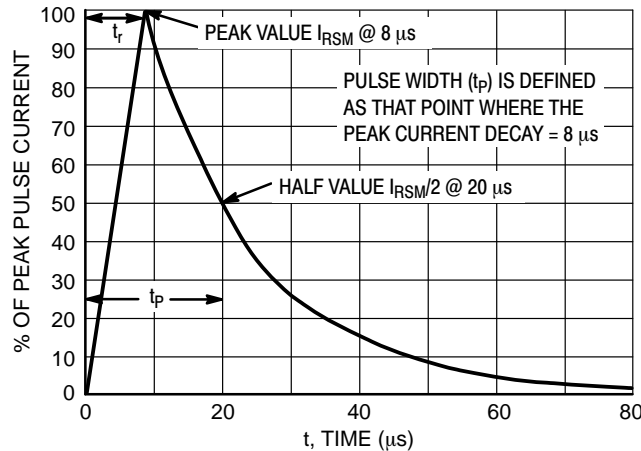
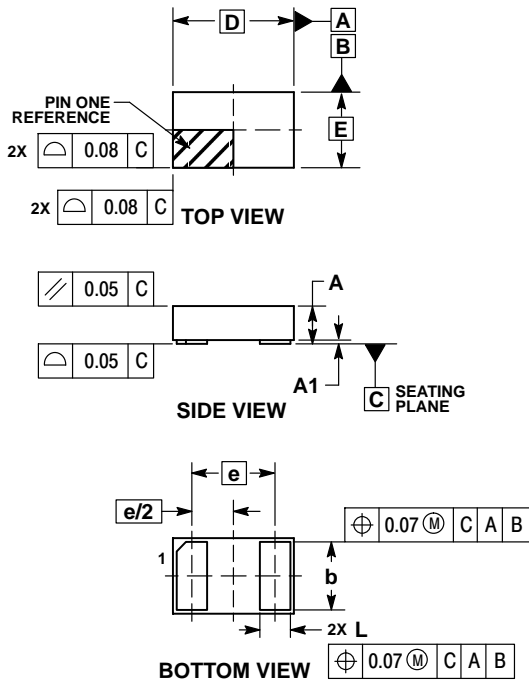

Figure 8. 8 X 20 μs Pulse Waveform

# ESD8501V5

## PACKAGE DIMENSIONS

### UDFN2 1.6x1.0, 1.1P CASE 517CZ ISSUE A



**NOTES:**

1. DIMENSIONING AND TOLERANCING PER ASME Y14.5M, 1994.
2. CONTROLLING DIMENSION: MILLIMETERS.

| DIM | MILLIMETERS |      |
|-----|-------------|------|
|     | MIN         | MAX  |
| A   | 0.45        | 0.55 |
| A1  | ---         | 0.05 |
| b   | 0.85        | 0.95 |
| D   | 1.60        | BSC  |
| E   | 1.00        | BSC  |
| e   | 1.10        | BSC  |
| L   | 0.35        | 0.45 |

### RECOMMENDED SOLDERING FOOTPRINT\*

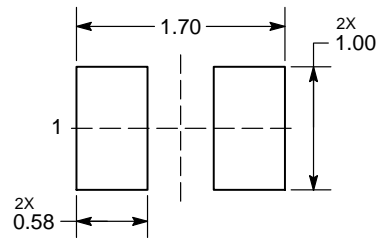

DIMENSIONS: MILLIMETERS

\*For additional information on our Pb-Free strategy and soldering details, please download the ON Semiconductor Soldering and Mounting Techniques Reference Manual, SOLDERRM/D.

ON Semiconductor and are registered trademarks of Semiconductor Components Industries, LLC (SCILLC). SCILLC owns the rights to a number of patents, trademarks, copyrights, trade secrets, and other intellectual property. A listing of SCILLC's product/patent coverage may be accessed at [www.onsemi.com/site/pdf/Patent-Marking.pdf](http://www.onsemi.com/site/pdf/Patent-Marking.pdf). SCILLC reserves the right to make changes without further notice to any products herein. SCILLC makes no warranty, representation or guarantee regarding the suitability of its products for any particular purpose, nor does SCILLC assume any liability arising out of the application or use of any product or circuit, and specifically disclaims any and all liability, including without limitation special, consequential or incidental damages. "Typical" parameters which may be provided in SCILLC data sheets and/or specifications can and do vary in different applications and actual performance may vary over time. All operating parameters, including "Typicals" must be validated for each customer application by customer's technical experts. SCILLC does not convey any license under its patent rights nor the rights of others. SCILLC products are not designed, intended, or authorized for use as components in systems intended for surgical implant into the body, or other applications intended to support or sustain life, or for any other application in which the failure of the SCILLC product could create a situation where personal injury or death may occur. Should Buyer purchase or use SCILLC products for any such unintended or unauthorized application, Buyer shall indemnify and hold SCILLC and its officers, employees, subsidiaries, affiliates, and distributors harmless against all claims, costs, damages, and expenses, and reasonable attorney fees arising out of, directly or indirectly, any claim of personal injury or death associated with such unintended or unauthorized use, even if such claim alleges that SCILLC was negligent regarding the design or manufacture of the part. SCILLC is an Equal Opportunity/Affirmative Action Employer. This literature is subject to all applicable copyright laws and is not for resale in any manner.

### PUBLICATION ORDERING INFORMATION

**LITERATURE FULFILLMENT:**

Literature Distribution Center for ON Semiconductor  
P.O. Box 5163, Denver, Colorado 80217 USA  
Phone: 303-675-2175 or 800-344-3860 Toll Free USA/Canada  
Fax: 303-675-2176 or 800-344-3867 Toll Free USA/Canada  
Email: [orderlit@onsemi.com](mailto:orderlit@onsemi.com)

**N. American Technical Support:** 800-282-9855 Toll Free  
USA/Canada  
**Europe, Middle East and Africa Technical Support:**  
Phone: 421 33 790 2910  
**Japan Customer Focus Center**  
Phone: 81-3-5817-1050

**ON Semiconductor Website:** [www.onsemi.com](http://www.onsemi.com)

**Order Literature:** <http://www.onsemi.com/orderlit>

For additional information, please contact your local Sales Representative