

DS90UB913A-Q1 25-MHz to 100-MHz 10/12-Bit FPD-Link III Serializer

1 Features

- Qualified for Automotive Applications AEC-Q100
 - Device Temperature Grade 2: -40°C to +105°C Ambient Operating Temperature Range
 - Device HBM ESD Classification Level ±8kV
 - Device CDM ESD Classification Level C6
- 25-MHz to 100-MHz Input Pixel Clock Support
- Programmable Data Payload:
 - 10-bit Payload up to 100 MHz
 - 12-bit Payload up to 75 MHz
- Continuous Low Latency Bidirectional Control Interface Channel with I2C Support @400 kHz
- Embedded Clock with DC-Balanced Coding to Support AC-Coupled Interconnects
- Capable of Driving up to 15m Coaxial or 20m Shielded Twisted-pair Cables
- Robust Power-Over-Coaxial (PoC) Operation
- 4 Dedicated General Purpose Input/Output
- 1.8-V, 2.8-V or 3.3-V-Compatible Parallel Inputs on Serializer
- Single Power Supply at 1.8 V
- ISO 10605 and IEC 61000-4-2 ESD Compliant
- Small Serializer Footprint (5 mm x 5 mm)

2 Applications

- Automotive
 - Surround View Systems (SVS)
 - Rear and Front View Cameras
 - Driver Monitor Cameras (DMS)
 - Remote Satellite RADAR Sensors
- Security and Surveillance
- Industrial Machine Vision

3 Description

The DS90UB913A-Q1 device offers an FPD-Link III interface with a high-speed forward channel and a bidirectional control channel for data transmission over a single coaxial cable or differential pair. The DS90UB913A-Q1 device incorporates differential signaling on both the high-speed forward channel and bidirectional control channel data paths. The serializer/deserializer pair is targeted for connections between imagers and video processors in an ECU (Electronic Control Unit). This device is ideally suited for driving video data requiring up to 12-bit pixel depth plus two synchronization signals along with bidirectional control channel bus.

Using TI's embedded clock technology allows transparent full-duplex communication over a single differential pair, carrying asymmetrical-bidirectional control channel information. This single serial stream simplifies transferring a wide data bus over PCB traces and cable by eliminating the skew problems between parallel data and clock paths. This significantly saves system cost by narrowing data paths that in turn reduce PCB layers, cable width, and connector size and pins. Internal DC-balanced encoding/decoding is used to support AC-coupled interconnects.

Device Information⁽¹⁾

PART NUMBER	PACKAGE	BODY SIZE (NOM)
DS90UB913A-Q1	WQFN (32)	5.00 mm x 5.00 mm

(1) For all available packages, see the orderable addendum at the end of the datasheet.

Simplified Schematic

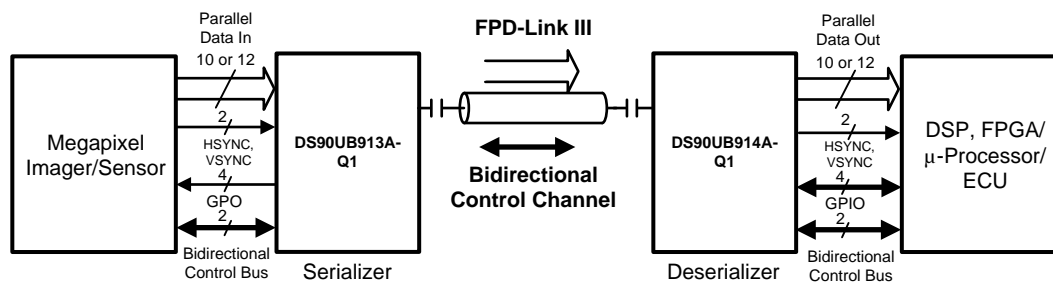

Table of Contents

1 Features	1	8.2 Functional Block Diagram	16
2 Applications	1	8.3 Feature Description	17
3 Description	1	8.4 Device Functional Modes	20
4 Revision History	2	8.5 Programming	25
5 Device Comparison Table	4	8.6 Register Maps	29
6 Pin Configuration and Functions	4	9 Application and Implementation	35
7 Specifications	6	9.1 Application Information	35
7.1 Absolute Maximum Ratings	6	9.2 Typical Applications	37
7.2 ESD Ratings	6	10 Power Supply Recommendations	41
7.3 Recommended Operating Conditions	6	11 Layout	42
7.4 Thermal Information	7	11.1 Layout Guidelines	42
7.5 Electrical Characteristics	7	11.2 Layout Example	43
7.6 Recommended Serializer Timing For PCLK	10	12 Device and Documentation Support	45
7.7 AC Timing Specifications (SCL, SDA) - I2C- Compatible	11	12.1 Documentation Support	45
7.8 Bidirectional Control Bus DC Timing Specifications (SCL, SDA) - I2C-Compatible	11	12.2 Community Resources	45
7.9 Serializer Switching Characteristics	14	12.3 Trademarks	45
7.10 Typical Characteristics	15	12.4 Electrostatic Discharge Caution	45
8 Detailed Description	16	12.5 Glossary	45
8.1 Overview	16	13 Mechanical, Packaging, and Orderable Information	45

4 Revision History

Changes from Revision B (December 2014) to Revision C

Page

• Split document into two separate documents for parts DS90UB913A-Q1 and DS90UB914A-Q1.	1
• Modified Automotive Features	1
• Updated pin description for DIN to include active/inactive outputs corresponding to MODE setting	4
• Added pin description to GPO pins to leave open if unused.	5
• Changed Air Discharge ESD Rating (IEC61000-4-2: RD = 330 Ω, CS = 150 pF) to minimum ±25000 V.	6
• Added RTV text to Thermal Information table	7
• Added GPO[3:0] typical pin capacitances.	7
• Changed Differential Output Voltage minimum specification.	8
• Changed Single-Ended Output Voltage minimum specification.	8
• Added Back Channel Differential Input Voltage minimum specification	8
• Added Back Channel Single-Ended Input Voltage minimum specification.	8
• Updated IDDT for $V_{DD_n}=1.89V$, $V_{DDIO}=3.6V$, $RL=100\Omega$, Random Pattern with $f=100$ MHz, 10-bit mode to typical value of 65 mA; value is currently 54 mA.	9
• Updated IDDT for $V_{DD_n}=1.89V$, $V_{DDIO}=3.6V$, $RL=100\Omega$, Random Pattern with $f=75$ MHz, 12-bit high freq mode to typical value of 64 mA; value is currently 54 mA.	9
• Updated IDDT for $V_{DD_n}=1.89V$, $V_{DDIO}=3.6V$, $RL=100\Omega$, Random Pattern with $f=50$ MHz, 12-bit low freq mode to typical value of 63 mA; value is currently 54 mA.	9
• Updated frequency ranges for MODE settings and also revised with correct maximum clock periods. Added footnote and nominal clock period to be in terms of 'T'. ⁽⁵⁾	10
• Deleted Revised jitter freq. test conditions to be $> f/20$ and also updated typical values for t_{jit0} and t_{jit2}	10
• Updated V_{OL} Output Low Level row with revised I_{OL} currents and max V_{OL} voltages, dependent upon V_{DDIO} voltage.	11
• Updated Figure 2 title to state "Worst-Case" Test Pattern for Power Consumption'.	12
• Added footnote that states the following: "UI – Unit Interval is equivalent to one serialized data bit width. The UI scales with PCLK frequency." Add below calculations to footnote. 12-bit LF mode $1\text{ UI} = 1 / (\text{PCLK_Freq.} \times 28)$ 12-bit HF mode $1\text{ UI} = 1 / (\text{PCLK_Freq.} \times 2/3 \times 28)$ 10-bit mode $1\text{ UI} = 1 / (\text{PCLK_Freq.} / 2 \times 28)$	14

Revision History (continued)

• Updated frequency requirements for 10-bit and 12-bit HF modes. 10-bit mode – 50 MHz to 100 MHz; 12-bit HF mode – 37.5 MHz to 75 MHz; 12-bit LF mode (no change) – 25 MHz to 50 MHz.	16
• Updated register 0x01[1] default value to be “0”.....	29
• Changed GPO0 Enable for 0x0D[4] to GPO1 Enable.....	31
• Added Inject Forward Channel Error Register 0x2D.....	34
• Updated power up sequencing information and timing diagram.	35
• Added description specifying that the voltage applied on V_{DDIO} (1.8V, 3.3V) or V_{DD_n} (1.8V) should be at the input pin – any board level DC drop should be compensated.	41
• Added 913A EVM layout example image.	44

Changes from Revision A (June 2013) to Revision B

Page

• Added datasheet flow and layout to conform with new TI standards. Added the following sections: Device Comparison Table; Handling Ratings; Application and Implementation; Power Supply Recommendations; Layout; Device and Documentation Support; Mechanical, Packaging, and Ordering Information	1
• Added additional thermal characteristics.....	7
• Changed typo in Vout test condition from $R_L=500\Omega$ to $R_L=50\Omega$	8
• Changed Figure 6 to use V_{ODp-p} and to clarify difference between STP and Coax.....	12
• Added Internal Oscillator section to Device Functional Modes.....	22
• Added reference to Power over Coax Application report.....	35
• Added power up sequencing information and timing diagram.	35

5 Device Comparison Table

PART NUMBER	FPD-III FUNCTION	PACKAGE	TRANSMISSION MEDIA	PCLK FREQUENCY
DS90UB913Q-Q1	Serializer	WQFN RTV (32)	STP	10 to 100 MHz
DS90UB913A-Q1	Serializer	WQFN RTV (32)	Coax or STP	25 to 100 MHz

6 Pin Configuration and Functions

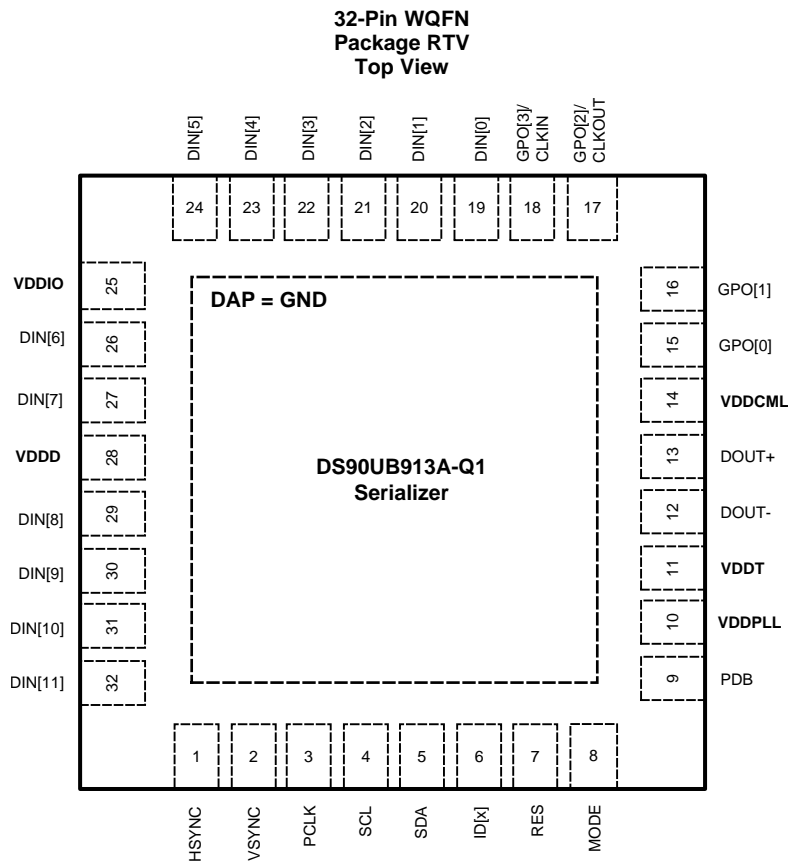

Pin Functions: DS90UB913A-Q1 Serializer

PIN		I/O	DESCRIPTION
NAME	NO.		
LVC MOS PARALLEL INTERFACE			
DIN[0:11]	19,20,21,22,23,24,26,27,29,30,31,32	Inputs, LVC MOS w/ pulldown	Parallel Data Inputs. For 10-bit MODE, parallel inputs DIN[0:9] are active. DIN[10:11] are inactive and should not be used. Any unused inputs (including DIN[10:11]) should be No Connect. For 12-bit MODE (HF or LF), parallel inputs DIN[0:11] are active. Any unused inputs should be No Connect.
HSYNC	1	Input, LVC MOS w/ pulldown	Horizontal SYNC Input. Note: HS transition restrictions: 1. 12-bit Low-Frequency mode: No HS restrictions (raw) 2. 12-bit High-Frequency mode: No HS restrictions (raw) 3. 10-bit mode: HS restricted to no more than one transition per 10 PCLK cycles. Leave open if unused.
VSYNC	2	Input, LVC MOS w/ pulldown	Vertical SYNC Input. Note: VS transition restrictions: 1. 12-bit Low-Frequency mode: No VS restrictions (raw) 2. 12-bit High-Frequency mode: No VS restrictions (raw) 3. 10-bit High-Frequency mode: VS restricted to no more than one transition per 10 PCLK cycles. Leave open if unused.
PCLK	3	Input, LVC MOS w/ pulldown	Pixel Clock Input Pin. Strobe edge set by TRFB control register.

Pin Functions: DS90UB913A-Q1 Serializer (continued)

PIN		I/O	DESCRIPTION
NAME	NO.		
GENERAL PURPOSE OUTPUT (GPO)			
GPO[1:0]	16,15	Output, LVCMOS	General-purpose output pins can be configured as outputs; used to control and respond to various commands. GPO[1:0] can be configured to be the outputs for input signals coming from GPIO[1:0] pins on the Deserializer or can be configured to be outputs of the local register on the Serializer. Leave open if unused.
GPO[2]/CLKOUT	17	Output, LVCMOS	GPO[2] pin can be configured to be the output for input signal coming from the GPIO[2] pin on the Deserializer or can be configured to be the output of the local register on the Serializer. It can also be configured to be the output clock pin when the DS90UB913A-Q1 device is used in the External Oscillator mode. See Device Functional Modes section for a detailed description of External Oscillator Mode. Leave open if unused.
GPO[3]/CLKIN	18	Input/Output, LVCMOS	GPO[3] can be configured to be the output for input signals coming from the GPIO[3] pin on the Deserializer or can be configured to be the output of the local register setting on the Serializer. It can also be configured to be the input clock pin when the DS90UB913A-Q1 Serializer is working with an external oscillator. See Device Functional Modes section for a detailed description of External Oscillator Mode. Leave open if unused.
BIDIRECTIONAL CONTROL BUS - I2C-COMPATIBLE			
SCL	4	Input/Output, Open Drain	Clock line for the bidirectional control bus communication. SCL requires an external pullup resistor to V_{DDIO} .
SDA	5	Input/Output, Open Drain	Data line for the bidirectional control bus communication. SDA requires an external pullup resistor to V_{DDIO} .
MODE	8	Input, LVCMOS w/ pulldown	Device mode select. Resistor (Rmode) to Ground and 10-k Ω pullup to 1.8-V rail. MODE pin on the Serializer can be used to select whether the system is running off the PCLK from the imager or an external oscillator. See details in Table 1 .
ID[x]	6	Input, analog	Device ID Address Select. The ID[x] pin on the Serializer is used to assign the I2C device address. Resistor (RID) to Ground and 10-k Ω pullup to 1.8-V rail. See Table 5 .
CONTROL AND CONFIGURATION			
PDB	9	Input, LVCMOS w/ pulldown	Power down Mode Input Pin. PDB = H, Serializer is enabled and is ON. PDB = L, Serializer is in Power Down mode. When the Serializer is in Power Down, the PLL is shutdown, and IDD is minimized. Programmed control register data is NOT retained and reset to default values.
RES	7	Input, LVCMOS w/ pulldown	Reserved. This pin MUST be tied LOW.
FPD-Link III INTERFACE			
DOUT+	13	Input/Output, CML	Non-inverting differential output, bidirectional control channel input. The interconnect must be AC Coupled with a 0.1- μ F capacitor.
DOUT-	12	Input/Output, CML	Inverting differential output, bidirectional control channel input. The interconnect must be AC Coupled with a 0.1- μ F capacitor. For applications using single-ended coaxial interconnect, a 0.047- μ F AC coupling capacitor should be placed in series with a 50 Ω resistor before terminating to GND.
POWER AND GROUND⁽¹⁾			
VDDPLL	10	Power, Analog	PLL Power, 1.8 V \pm 5%.
VDDT	11	Power, Analog	Tx Analog Power, 1.8V \pm 5%.
VDDCML	14	Power, Analog	CML & Bidirectional Channel Driver Power, 1.8 V \pm 5%.
VDDD	28	Power, Digital	Digital Power, 1.8 V \pm 5%.
VDDIO	25	Power, Digital	Power for I/O stage. The single-ended inputs and SDA, SCL are powered from V_{DDIO} . V_{DDIO} can be connected to a 1.8V \pm 5% or 2.8V \pm 10% or 3.3V \pm 10%.
VSS	DAP	Ground, DAP	DAP must be grounded. DAP is the large metal contact at the bottom side, located at the center of the WQFN package. Connected to the ground plane (GND) with at least 9 vias.

(1) See [Power-Up Requirements and PDB Pin](#).

7 Specifications

7.1 Absolute Maximum Ratings

 over operating free-air temperature range (unless otherwise noted)⁽¹⁾

	MIN	MAX	UNIT
Supply Voltage – V_{DD_n} (1.8 V)	-0.3	2.5	V
Supply Voltage – V_{DDIO}	-0.3	4.0	V
LVC MOS Input Voltage	-0.3	$V_{DDIO} + 0.3$	V
CML Driver I/O Voltage (V_{DD})	-0.3	$V_{DD} + 0.3$	V
Junction Temperature		150	°C
Storage temperature range, T_{stg}	-65	150	°C

(1) Stresses beyond those listed under *Absolute Maximum Ratings* may cause permanent damage to the device. These are stress ratings only, which do not imply functional operation of the device at these or any other conditions beyond those indicated under *Recommended Operating Conditions*. Exposure to absolute-maximum-rated conditions for extended periods may affect device reliability.

7.2 ESD Ratings

			VALUE	UNIT	
$V_{(ESD)}$	Electrostatic discharge	Human body model (HBM), per AEC Q100-002 ⁽¹⁾	±8000	V	
		Charged device model (CDM), per AEC Q100-011	Corner pins (1, 8, 9, 16, 17, 24, 25, 32)		±1000
			Other pins		
ESD Rating (IEC 61000-4-2) $R_D = 330 \Omega$, $C_s = 150\text{pF}$	Air Discharge (DOUT+, DOUT-, RIN+, RIN-)	±25000	V		
	Contact Discharge (DOUT+, DOUT-, RIN+, RIN-)	±7000			
ESD Rating (ISO10605) $R_D = 330 \Omega$, $C_s = 150/330 \text{pF}$ $R_D = 2 \text{K}\Omega$, $C_s = 150/330 \text{pF}$	Air Discharge (DOUT+, DOUT-, RIN+, RIN-)	±15000			
	Contact Discharge (DOUT+, DOUT-, RIN+, RIN-)	±8000			

(1) AEC Q100-002 indicates HBM stressing is done in accordance with the ANSI/ESDA/JEDEC JS-001 specification.

7.3 Recommended Operating Conditions

over operating free-air temperature range (unless otherwise noted)

			MIN	NOM	MAX	UNIT
Supply Voltage (V_{DD_n})			1.71	1.8	1.89	V
LVC MOS Supply Voltage ($V_{DDIO} = 1.8\text{V}$) OR			1.71	1.8	1.89	V
LVC MOS Supply Voltage ($V_{DDIO} = 3.3\text{V}$) OR			3.0	3.3	3.6	
LVC MOS Supply Voltage ($V_{DDIO} = 2.8\text{V}$)			2.52	2.8	3.08	
Supply Noise ⁽¹⁾	V_{DD_n} (1.8 V)				25	mVp-p
	V_{DDIO} (1.8 V)				25	
	V_{DDIO} (3.3 V)				50	
Operating Free Air Temperature (T_A)			-40	25	105	°C
PCLK Clock Frequency			25		100	MHz

(1) Supply noise testing was done with minimum capacitors (as shown on [Figure 35](#), [Figure 31](#) on the PCB. A sinusoidal signal is AC coupled to the V_{DD_n} (1.8 V) supply with amplitude = 25 mVp-p measured at the device V_{DD_n} pins. Bit error rate testing of input to the Des and output of the Des with 10-meter cable shows no error when the noise frequency on the Ser is less than 1 MHz. The Des on the other hand shows no error when the noise frequency is less than 750 kHz.

7.4 Thermal Information

THERMAL METRIC ⁽¹⁾		DS90UB913A-Q1		UNIT
		RTV (WQFN)		
		32 PINS		
R _{θJA}	Junction-to-ambient thermal resistance	34.9		°C/W
R _{θJC(top)}	Junction-to-case (top) thermal resistance	8.8		
R _{θJB}	Junction-to-board thermal resistance	23.4		
ψ _{JT}	Junction-to-top characterization parameter	0.3		
ψ _{JB}	Junction-to-board characterization parameter	8.8		
R _{θJC(bot)}	Junction-to-case (bottom) thermal resistance	3.4		

(1) For more information about traditional and new thermal metrics, see the *IC Package Thermal Metrics* application report, [SPRA953](#).

7.5 Electrical Characteristics⁽¹⁾⁽²⁾⁽³⁾

Over recommended operating supply and temperature ranges unless otherwise specified.

PARAMETER	TEST CONDITIONS		MIN	TYP	MAX	UNIT
LVC MOS DC SPECIFICATIONS 3.3V I/O (SER INPUTS, GPIO, CONTROL INPUTS AND OUTPUTS)						
V _{IH}	High Level Input Voltage	V _{IN} = 3 V to 3.6 V	2		V _{IN}	V
V _{IL}	Low Level Input Voltage	V _{IN} = 3 V to 3.6 V	GND		0.8	V
I _{IN}	Input Current	V _{IN} = 0 V or 3.6 V, V _{IN} = 3 V to 3.6 V	-20	±1	20	μA
V _{OH}	High Level Output Voltage	V _{DDIO} = 3 V to 3.6 V, I _{OH} = -4 mA	2.4		V _{DDIO}	V
V _{OL}	Low Level Output Voltage	V _{DDIO} = 3 V to 3.6 V, I _{OL} = 4 mA	GND		0.4	V
I _{OS}	Output Short Circuit Current	V _{OUT} = 0 V		-15		mA
I _{OZ}	TRI-STATE Output Current	PDB = 0 V, V _{OUT} = 0 V or V _{DD}	-20		20	μA
C _{GPO}	Pin Capacitance	GPO [3:0]		1.5		pF
LVC MOS DC SPECIFICATIONS 1.8V I/O (SER INPUTS, GPIO, CONTROL INPUTS AND OUTPUTS)						
V _{IH}	High Level Input Voltage	V _{IN} = 1.71 V to 1.89 V	0.65 V _{IN}		V _{IN}	V
V _{IL}	Low Level Input Voltage	V _{IN} = 1.71 V to 1.89 V	GND		0.35 V _{IN}	V
I _{IN}	Input Current	V _{IN} = 0 V or 1.89 V, V _{IN} = 1.71 V to 1.89 V	-20	±1	20	μA
V _{OH}	High Level Output Voltage	V _{DDIO} = 1.71 V to 1.89 V, I _{OH} = -4 mA	V _{DDIO} - 0.45		V _{DDIO}	V
V _{OL}	Low Level Output Voltage	V _{DDIO} = 1.71 V to 1.89 V, I _{OL} = 4 mA	GND		0.45	V
I _{OS}	Output Short Circuit Current	V _{OUT} = 0 V		-11		mA
I _{OZ}	TRI-STATE Output Current	PDB = 0 V, V _{OUT} = 0 V or V _{DD}	-20		20	μA
C _{GPO}	Pin Capacitance	GPO [3:0]		1.5		pF

- (1) The Electrical Characteristics tables list verified specifications under the listed Recommended Operating Conditions except as otherwise modified or specified by the Electrical Characteristics Conditions and/or Notes. Typical specifications are estimations only and are not verified.
- (2) Current into device pins is defined as positive. Current out of a device pin is defined as negative. Voltages are referenced to ground except V_{OD} and ΔV_{OD} which are differential voltages.
- (3) Typical values represent most likely parametric norms at 1.8 V or 3.3 V, T_A = 25°C, and at the Recommended Operation Conditions at the time of product characterization and are not verified.

Electrical Characteristics⁽¹⁾⁽²⁾⁽³⁾ (continued)

Over recommended operating supply and temperature ranges unless otherwise specified.

PARAMETER		TEST CONDITIONS	MIN	TYP	MAX	UNIT
LVCMOS DC SPECIFICATIONS 2.8V I/O (SER INPUTS, GPIO, CONTROL INPUTS AND OUTPUTS)						
V _{IH}	High Level Input Voltage	V _{IN} = 2.52 V to 3.08 V	0.7 V _{IN}		V _{IN}	V
V _{IL}	Low Level Input Voltage	V _{IN} = 2.52 V to 3.08 V	GND		0.3 V _{IN}	
I _{IN}	Input Current	V _{IN} = 0 V or 3.08 V, V _{IN} = 2.52 V to 3.08 V	-20	±1	20	μA
V _{OH}	High Level Output Voltage	V _{DDIO} = 2.52 V to 3.08 V, I _{OH} = -4 mA	V _{DDIO} - 0.4		V _{DDIO}	V
V _{OL}	Low Level Output Voltage	V _{DDIO} = 2.52 V to 3.08 V, I _{OL} = 4 mA	GND		0.4	V
I _{OS}	Output Short Circuit Current	V _{OUT} = 0 V		-11		mA
I _{OZ}	TRI-STATE Output Current	PDB = 0 V, V _{OUT} = 0 V or V _{DD}	-20		20	μA
C _{GPO}	Pin Capacitance	GPO [3:0]		1.5		pF
CML DRIVER DC SPECIFICATIONS (DOUT+, DOUT-)						
V _{OD}	Differential Output Voltage	R _L = 100 Ω (Figure 6), Back Channel Disabled	640		824	mV
V _{OUT}	Single-Ended Output Voltage	R _L = 50 Ω (Figure 6), Back Channel Disabled	320		412	
ΔV _{OD}	Differential Output Voltage Unbalance	R _L = 100 Ω		1	50	mV
V _{OS}	Output Offset Voltage	R _L = 100 Ω (Figure 6)		V _{DD} - V _{OD} /2		V
ΔV _{OS}	Offset Voltage Unbalance	R _L = 100 Ω		1	50	mV
I _{OS}	Output Short Circuit Current	DOUT+ = 0 V or DOUT- = 0 V		-26		mA
R _T	Differential Internal Termination Resistance	Differential across DOUT+ and DOUT-	80	100	120	Ω
	Single-ended Termination Resistance	DOUT+ or DOUT-	40	50	60	
V _{ID-BC}	Back Channel Differential Input Voltage		260			mV
V _{IN-BC}	Back Channel Single-Ended Input Voltage		130			mV

Electrical Characteristics⁽¹⁾⁽²⁾⁽³⁾ (continued)

Over recommended operating supply and temperature ranges unless otherwise specified.

PARAMETER	TEST CONDITIONS	MIN	TYP	MAX	UNIT	
SERIALIZER SUPPLY CURRENT						
I_{DDT}	Serializer (Tx) $V_{DD,n}$ Supply Current (includes load current)	$R_L = 100\ \Omega$ WORST CASE pattern (Figure 2)	$V_{DD,n} = 1.89\ V$ $V_{DDIO} = 3.6\ V$ $f = 100\ \text{MHz}$, 10-bit mode Default Registers	61	80	mA
			$V_{DD,n} = 1.89\ V$ $V_{DDIO} = 3.6\ V$ $f = 75\ \text{MHz}$, 12-bit high frequency mode Default Registers	61	80	
			$V_{DD,n} = 1.89\ V$ $V_{DDIO} = 3.6\ V$ $f = 50\ \text{MHz}$, 12-bit low frequency mode Default Registers	61	80	
I_{DDT}	Serializer (Tx) $V_{DD,n}$ Supply Current (includes load current)	$R_L = 100\ \Omega$ RANDOM PRBS-7 pattern	$V_{DD,n} = 1.89\ V$ $V_{DDIO} = 3.6\ V$ $f = 100\ \text{MHz}$, 10-bit mode Default Registers	65		mA
			$V_{DD,n} = 1.89\ V$ $V_{DDIO} = 3.6\ V$ $f = 75\ \text{MHz}$, 12-bit high frequency mode Default Registers	64		
			$V_{DD,n} = 1.89\ V$ $V_{DDIO} = 3.6\ V$ $f = 50\ \text{MHz}$, 12-bit low frequency mode Default Registers	63		
I_{DDIOT}	Serializer (Tx) V_{DDIO} Supply Current (includes load current)	$R_L = 100\ \Omega$ WORST CASE pattern (Figure 2)	$V_{DDIO} = 1.89\ V$ $f = 75\ \text{MHz}$, 12-bit high frequency mode Default Registers	1.5	3	mA
			$V_{DDIO} = 3.6\ V$ $f = 75\ \text{MHz}$, 12-bit high frequency mode Default Registers	5	8	
I_{DDTZ}	Serializer (Tx) Supply Current Power Down	PDB = 0V; All other LVCMOS Inputs = 0 V	$V_{DDIO} = 1.89\ V$ Default Registers	300	1000	μA
			$V_{DDIO} = 3.6\ V$ Default Registers	300	1000	μA
I_{DDIOTZ}	Serializer (Tx) V_{DDIO} Supply Current Power Down	PDB = 0V; All other LVCMOS Inputs = 0 V	$V_{DDIO} = 1.89\ V$ Default Registers	15	100	μA
			$V_{DDIO} = 3.6\ V$ Default Registers	15	100	μA

7.6 Recommended Serializer Timing For PCLK⁽¹⁾ (2)

Over recommended operating supply and temperature ranges unless otherwise specified.

PARAMETER	TEST CONDITIONS	PIN / FREQ	MIN	NOM	MAX	UNIT
t _{TCP} Transmit Clock Period	10-bit mode 50 MHz – 100 MHz		10	T	20	ns
	12-bit high frequency mode 37.5 MHz - 75MHz		13.33	T	26.67	ns
	12-bit low frequency mode 25 MHz - 50MHz		20	T	40	ns
t _{TCIH} Transmit Clock Input High Time			0.4T	0.5T	0.6T	ns
t _{TCIL} Transmit Clock Input Low Time			0.4T	0.5T	0.6T	ns
t _{CLKT} PCLK Input Transition Time (Figure 7)	10-bit mode 50 MHz – 100 MHz		0.05T	0.25T	0.3T	ns
	12-bit high frequency mode 37.5 MHz - 75MHz		0.05T	0.25T	0.3T	ns
	12-bit low frequency mode 25 MHz - 50MHz		0.05T	0.25T	0.3T	ns
t _{JIT0} PCLK Input Jitter (PCLK from imager mode)	Refer to Jitter freq > f/20	f = 25 – 100 MHz		0.01T		ns
t _{JIT1} PCLK Input Jitter (External Oscillator mode)	Refer to Jitter freq > f/20	f = 25 – 100 MHz		1T		ns
t _{JIT2} External Oscillator Jitter	Refer to Jitter freq > f/20			0.01T		ns

(1) Recommended Input Timing Requirements are input specifications and not tested in production.

(2) T is the period of the PCLK.

7.7 AC Timing Specifications (SCL, SDA) - I2C-Compatible

Over recommended supply and temperature ranges unless otherwise specified. (Figure 1)

PARAMETER	TEST CONDITIONS	MIN	NOM	MAX	UNIT
RECOMMENDED INPUT TIMING REQUIREMENTS					
f _{SCL}	SCL Clock Frequency	Standard Mode		100	kHz
		Fast Mode		400	kHz
t _{LOW}	SCL Low Period	Standard Mode	4.7		μs
		Fast Mode	1.3		μs
t _{HIGH}	SCL High Period	Standard Mode	4.0		μs
		Fast Mode	0.6		μs
t _{HD:STA}	Hold time for a start or a repeated start condition	Standard Mode	4.0		μs
		Fast Mode	0.6		μs
t _{SU:STA}	Set Up time for a start or a repeated start condition	Standard Mode	4.7		μs
		Fast Mode	0.6		μs
t _{HD:DAT}	Data Hold Time	Standard Mode	0	3.45	μs
		Fast Mode	0	900	ns
t _{SU:DAT}	Data Set Up Time	Standard Mode	250		ns
		Fast Mode	100		ns
t _{SU:STO}	Set Up Time for STOP Condition	Standard Mode	4.0		μs
		Fast Mode	0.6		μs
t _{BUF}	Bus Free time between Stop and Start	Standard Mode	4.7		μs
		Fast Mode	1.3		μs
t _r	SCL & SDA Rise Time	Standard Mode		1000	ns
		Fast Mode		300	ns
t _f	SCL & SDA Fall Time	Standard Mode		300	ns
		Fast Mode		300	ns

7.8 Bidirectional Control Bus DC Timing Specifications (SCL, SDA) - I2C-Compatible⁽¹⁾

Over recommended supply and temperature ranges unless otherwise specified

PARAMETER	TEST CONDITIONS	MIN	NOM	MAX	UNIT
RECOMMENDED INPUT TIMING REQUIREMENTS					
V _{IH}	Input High Level	SDA and SCL	0.7*V _{DDIO}	V _{DDIO}	V
V _{IL}	Input Low Level	SDA and SCL	GND	0.3*V _{DDIO}	V
V _{HY}	Input Hysteresis		>50		mV
V _{OL}	Output Low Level ⁽²⁾	SDA, V _{DDIO} = 1.8V, I _{OL} = 0.9 mA	0	0.36	V
		SDA, V _{DDIO} = 3.3V, I _{OL} = 1.6 mA	0	0.4	
I _{IN}	Input Current	SDA or SCL, V _{IN} = V _{DDIO} OR GND	-10	10	μA
t _R	SDA Rise Time-READ	SDA, RPU = 10 kΩ, C _b ≤ 400 pF (Figure 1)		430	ns
t _F	SDA Fall Time-READ			20	ns
t _{SU:DAT}		(See Figure 1)		560	ns
t _{HD:DAT}		(See Figure 1)		615	ns
C _{IN}		SDA or SCL		<5	pF

(1) Specification is verified by design.

(2) FPD-Link device was designed primarily for point-to-point operation and a small number of attached slave devices. As such the Minimum I_{OL} pullup current is targeted to lower value than the minimum I_{OL} in the I2C specification.

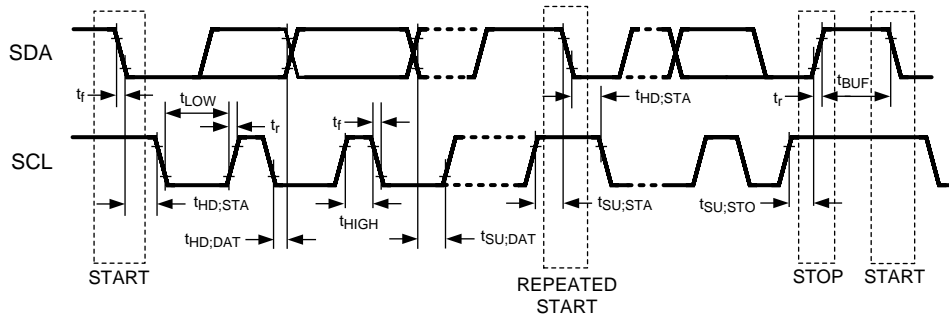

Figure 1. Bi-directional Control Bus Timing

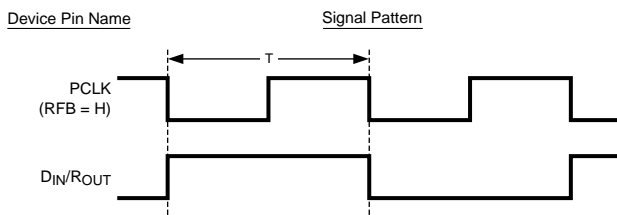

Figure 2. "Worst Case" Test Pattern for Power Consumption

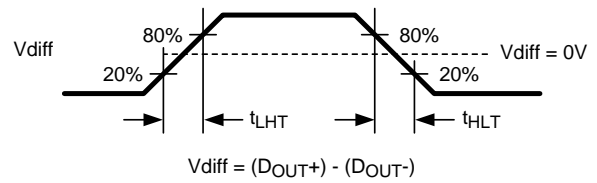

Figure 3. Serializer CML Output Load and Transition Times

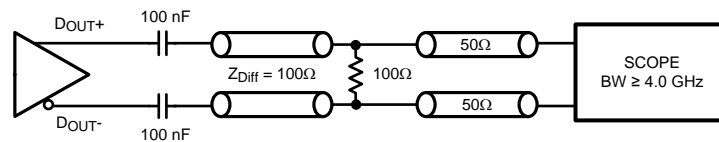

Figure 4. Serializer CML Output Load and Transition Times

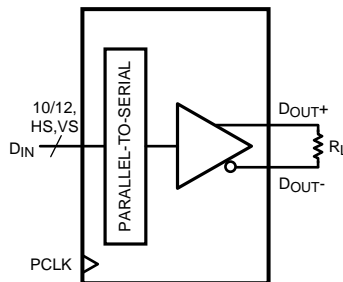

Figure 5. Serializer VOD Setup

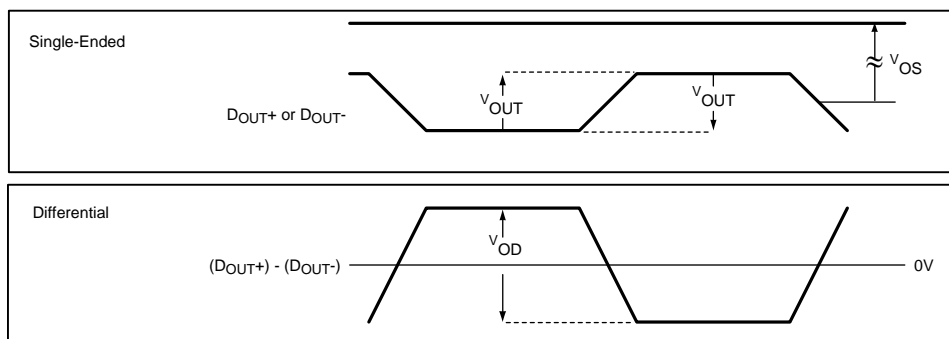

Figure 6. Serializer VOD Diagram

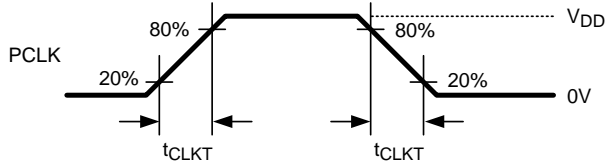

Figure 7. Serializer Input Clock Transition Times

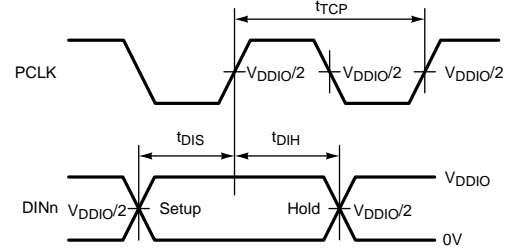

Figure 8. Serializer Setup/Hold Times

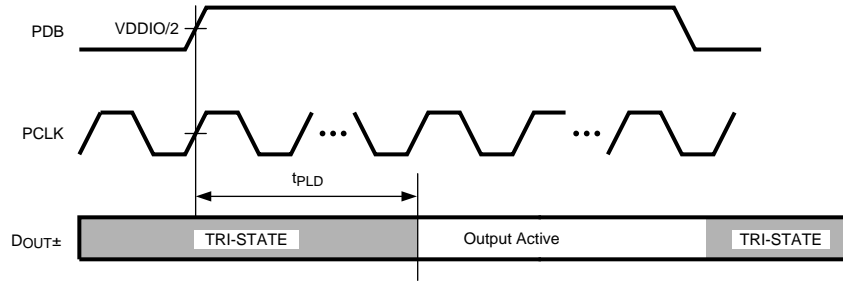

Figure 9. Serializer PLL Lock Time

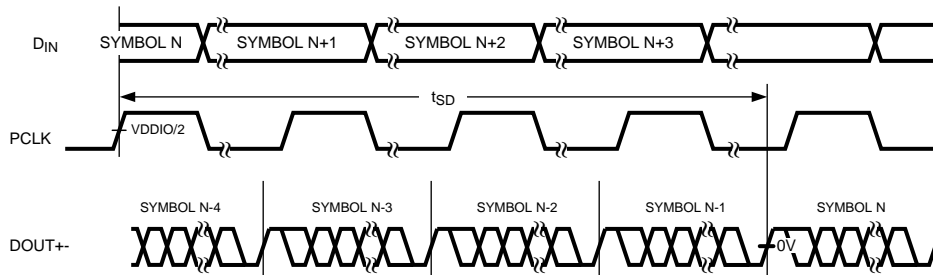

Figure 10. Serializer Delay

7.9 Serializer Switching Characteristics

Over recommended operating supply and temperature ranges unless otherwise specified.

PARAMETER	TEST CONDITIONS	MIN	NOM	MAX	UNIT
t_{LHT}	CML Low-to-High Transition Time $R_L = 100 \Omega$ (Figure 3)		150	330	ps
t_{HLT}	CML High-to-Low Transition Time $R_L = 100 \Omega$ (Figure 3)		150	330	ps
t_{DIS}	Data Input Setup to PCLK	2			ns
t_{DIH}	Data Input Hold from PCLK	2			ns
t_{PLD}	Serializer PLL Lock Time ⁽¹⁾⁽²⁾ $R_L = 100 \Omega$ (Figure 9)		1	2	ms
t_{SD}	Serializer Delay ⁽²⁾ $R_T = 100 \Omega$, 10-bit mode Register 0x03h b[0] (TRFB = 1) (Figure 10)	32.5T	38T	44T	ns
	$R_T = 100 \Omega$, 12-bit mode Register 0x03h b[0] (TRFB = 1) (Figure 10)	11.75T	13T	15T	ns
t_{JIND}	Serializer Output Deterministic Jitter ⁽³⁾⁽⁴⁾⁽⁵⁾ Serializer output intrinsic deterministic jitter. Measured (cycle-cycle) with PRBS-7 test pattern		0.13		UI
t_{JINR}	Serializer Output Random Jitter ⁽³⁾⁽⁴⁾⁽⁵⁾ Serializer output intrinsic random jitter (cycle-cycle). Alternating-1,0 pattern.		0.04		UI
t_{JINT}	Peak-to-peak Serializer Output Jitter ⁽³⁾⁽⁴⁾⁽⁵⁾ Serializer output peak-to-peak jitter includes deterministic jitter, random jitter, and jitter transfer from serializer input. Measured (cycle-cycle) with PRBS-7 test pattern.		0.396		UI
λ_{STXBW}	Serializer Jitter Transfer Function -3 dB Bandwidth 10-bit mode PCLK = 100 MHz. Default Registers		2.20		MHz
	12-bit high frequency mode PCLK = 75 MHz. Default Registers		2.20		
	12-bit low frequency mode PCLK = 50 MHz. Default Registers		2.20		
δ_{STX}	Serializer Jitter Transfer Function (Peaking) 10-bit mode PCLK = 100 MHz. Default Registers		1.06		dB
	12-bit high frequency mode PCLK = 75 MHz. Default Registers		1.09		
	12-bit low frequency mode PCLK = 50 MHz. Default Registers		1.16		
δ_{STXf}	Serializer Jitter Transfer Function (Peaking Frequency) 10-bit mode PCLK = 100 MHz. Default Registers		400		kHz
	12-bit high frequency mode PCLK = 75 MHz. Default Registers		500		
	12-bit low frequency mode PCLK = 50 MHz. Default Registers		600		

- (1) t_{PLD} and t_{DDL} are the times required by the serializer and deserializer to obtain lock when exiting power-down state with an active PCLK
- (2) Specification is verified by design.
- (3) Typical values represent most likely parametric norms at 1.8 V or 3.3 V, $T_A = 25^\circ\text{C}$, and at the Recommended Operation Conditions at the time of product characterization and are not verified.
- (4) Specification is verified by characterization and is not tested in production.
- (5) UI – Unit Interval is equivalent to one ideal serialized data bit width. The UI scales with PCLK frequency.
 10-bit mode: $1 \text{ UI} = 1 / (\text{PCLK_Freq.} / 2 \times 28)$
 12-bit HF mode: $1 \text{ UI} = 1 / (\text{PCLK_Freq.} \times 2/3 \times 28)$
 12-bit LF mode: $1 \text{ UI} = 1 / (\text{PCLK_Freq.} \times 28)$

7.10 Typical Characteristics

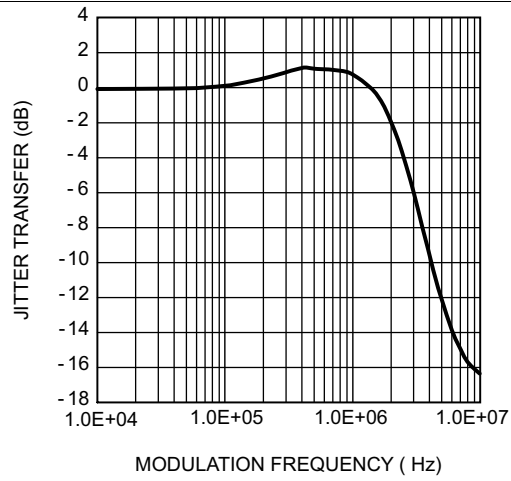

Figure 11. Typical Serializer Jitter Transfer Function

8 Detailed Description

8.1 Overview

The DS90UB913A-Q1 is optimized to interface with the DS90UB914A-Q1 using a 50-Ω coax interface. The DS90UB913A-Q1 will also work with the DS90UB914A-Q1 using an STP interface.

The DS90UB913A/914A FPD- Link III chipsets are intended to link mega-pixel camera imagers and video processors in ECUs. The Serializer/Deserializer chipset can operate from 25 MHz to 100 MHz pixel clock frequency. The DS90UB913A-Q1 device transforms a 10/12-bit wide parallel LVC MOS data bus along with a bidirectional control channel control bus into a single high-speed differential pair. The high speed serial bit stream contains an embedded clock and DC-balanced information which enhances signal quality to support AC coupling. The DS90UB914A-Q1 device receives the single serial data stream and converts it back into a 10/12-bit wide parallel data bus together with the control channel data bus. The DS90UB913A/914A chipsets can accept up to:

- 12-bits of DATA + 2 bits SYNC for an input PCLK range of 25 MHz to 50 MHz in the 12-bit low frequency mode. Note: No HS/VS restrictions (raw).
- 12-bits of DATA + 2 SYNC bits for an input PCLK range of 37.5 MHz to 75 MHz in the 12-bit high frequency mode. Note: No HS/VS restrictions (raw).
- 10-bits of DATA + 2 SYNC bits for an input PCLK range of 50 MHz to 100 MHz in the 10-bit mode. Note: HS/VS restricted to no more than one transition per 10 PCLK cycles.

The DS90UB913A/914A chipset offer customers the choice to work with different clocking schemes. The DS90UB913A/914A chipsets can use an external oscillator as the reference clock source for the PLL (see section [DS90UB913A/914A Operation with External Oscillator as Reference Clock](#)) or PCLK from the imager as primary reference clock to the PLL (see section [DS90UB913A/914A Operation with Pixel Clock from Imager as Reference Clock](#)).

8.2 Functional Block Diagram

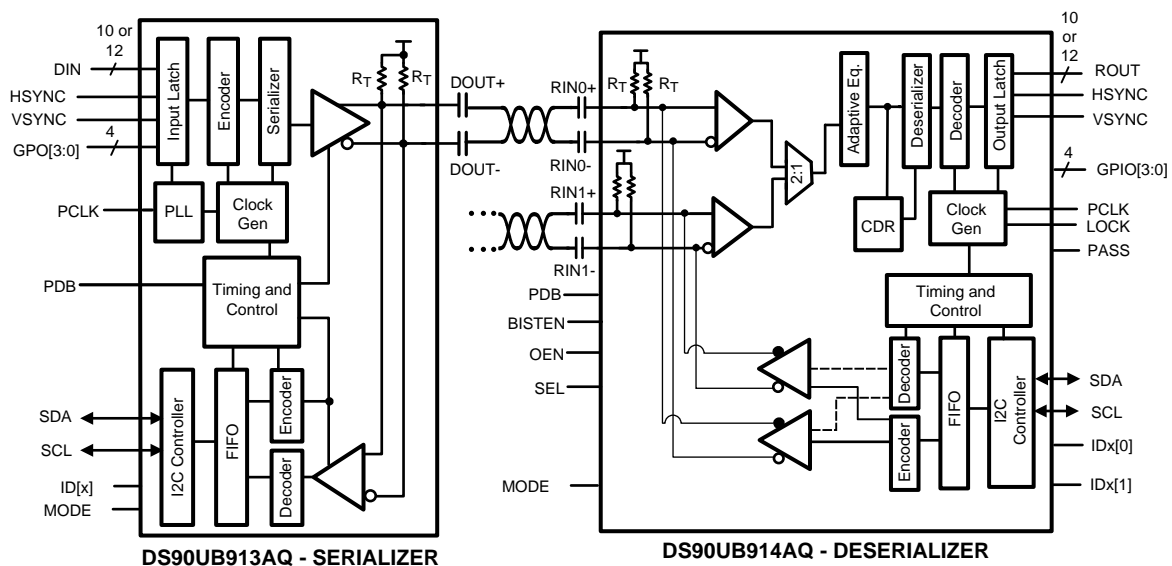

8.3 Feature Description

8.3.1 Serial Frame Format

The High Speed Forward Channel is composed of 28 bits of data containing video data, sync signals, I2C and parity bits. This data payload is optimized for signal transmission over an AC-coupled link. Data is randomized, balanced and scrambled. The 28-bit frame structure changes in the 12-bit low frequency mode, 12-bit high frequency mode and the 10-bit mode internally and is seamless to the customer. The bidirectional control channel data is transferred over the single serial link along with the high-speed forward data. This architecture provides a full duplex low speed forward and backward path across the serial link together with a high speed forward channel without the dependence on the video blanking phase.

8.3.2 Line Rate Calculations for the DS90UB913A/914A

The DS90UB913A-Q1 device divides the clock internally by divide-by-1 in the 12-bit low frequency mode, by divide-by-2 in the 10-bit mode and by divide-by-1.5 in the 12-bit high frequency mode. Conversely, the DS90UB914A-Q1 multiplies the recovered serial clock to generate the proper pixel clock output frequency. Thus the maximum line rate in the three different modes remains 1.4 Gbps. The following are the formulae used to calculate the maximum line rate in the different modes:

- For the 12-bit low frequency mode, Line rate = $f_{PCLK} * 28$; for example, $f_{PCLK} = 50$ MHz, line rate = $50 * 28 = 1.4$ Gbps
- For the 12-bit high frequency mode, Line rate = $f_{PCLK} * (2/3) * 28$; for example, $f_{PCLK} = 75$ MHz, line rate = $(75) * (2/3) * 28 = 1.4$ Gbps
- For the 10-bit mode, Line rate = $f_{PCLK} / 2 * 28$; for example, $f_{PCLK} = 100$ MHz, line rate = $(100/2) * 28 = 1.4$ Gbps

8.3.3 Error Detection

The chipset provides error detection operations for validating data integrity in long distance transmission and reception. The data error detection function offers users flexibility and usability of performing bit-by-bit data transmission error checking. The error detection operating modes support data validation of the following signals:

- Bidirectional control channel data across the serial link
- Parallel video/sync data across the serial link

The chipset provides 1 parity bit on the forward channel and 4 cyclic redundancy check (CRC) bits on the back channel for error detection purposes. The DS90UB913A/914A chipset checks the forward and back channel serial links for errors and stores the number of detected errors in two 8-bit registers in the Serializer and the Deserializer respectively.

To check parity errors on the forward channel, monitor registers 0x1A and 0x1B on the DS90UB914A. If there is a loss of LOCK, then the counters on registers 0x1A and 0x1B are reset. ***Whenever there is a parity error on the forward channel, the PASS pin will go low.***

To check CRC errors on the back-channel, monitor registers 0x0A and 0x0B on the Serializer.

Feature Description (continued)

8.3.4 Synchronizing Multiple Cameras

For applications requiring multiple cameras for frame-synchronization, it is recommended to utilize the General Purpose Input/Output (GPIO) pins to transmit control signals to synchronize multiple cameras together. To synchronize the cameras properly, the system controller needs to provide a field sync output (such as a vertical or frame sync signal) and the cameras must be set to accept an auxiliary sync input. The vertical synchronize signal corresponds to the start and end of a frame and the start and end of a field. Note this form of synchronization timing relationship has a non-deterministic latency. After the control data is reconstructed from the bidirectional control channel, there will be a time variation of the GPIO signals arriving at the different target devices (between the parallel links). The maximum latency delta (t_1) of the GPIO data transmitted across multiple links is 25 μ s.

NOTE

The user must verify that the timing variations between the different links are within their system and timing specifications.

See [Figure 12](#) for an example of this function.

The maximum time (t_1) between the rising edge of GPIO (that is, sync signal) to the time the signal arrives at Camera A and Camera B is 25 μ s.

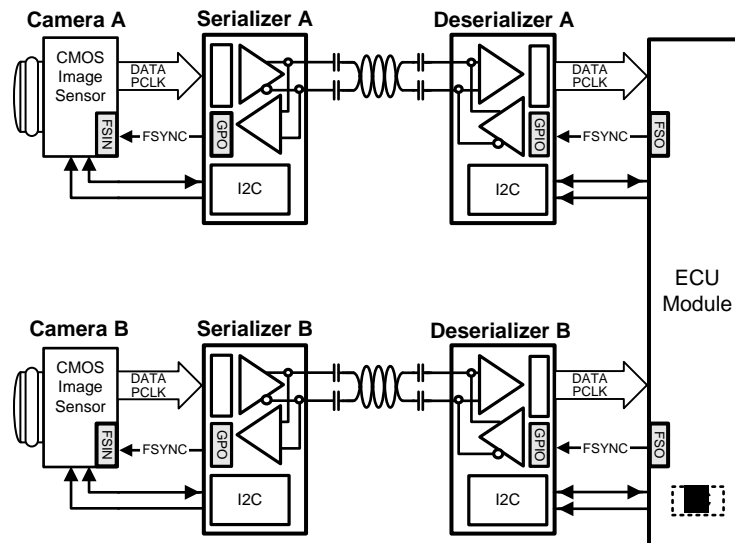

Figure 12. Synchronizing Multiple Cameras

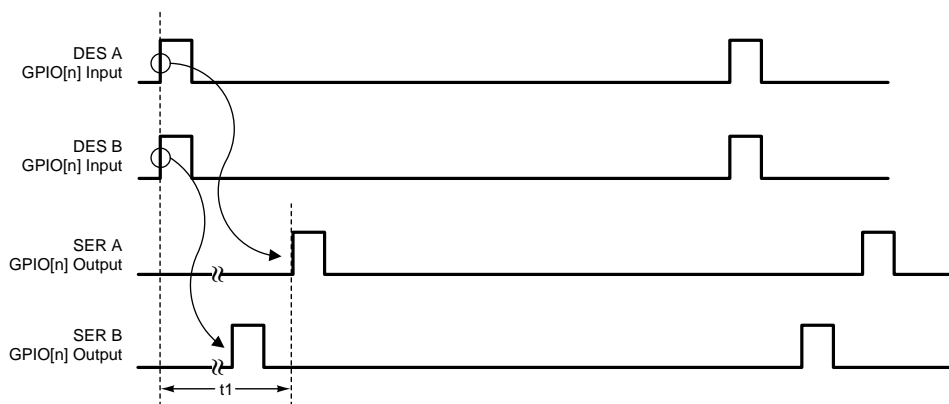

Figure 13. GPIO Delta Latency

Feature Description (continued)

8.3.5 General Purpose I/O (GPIO) Descriptions

There are 4 GPOs on the Serializer and 4 GPIOs on the Deserializer when the DS90UB913A/914A chipsets are run off the pixel clock from the imager as the reference clock source. The GPOs on the Serializer can be configured as outputs for the input signals that are fed into the Deserializer GPIOs. In addition, the GPOs on the Serializer can behave as outputs of the local register on the Serializer. The GPIOs on the Deserializer can be configured to be the input signals feeding the GPOs (configured as outputs) on the Serializer. In addition the GPIOs on the Deserializer can be configured to behave as outputs of the local register on the Deserializer. The DS90UB913A Serializer GPOs cannot be configured as inputs for remote communication with Deserializer. If the DS90UB913A/914A chipsets are run off the external oscillator source as the reference clock, then GPO3 on the Serializer is automatically configured to be the input for the external clock and GPO2 is configured to be the output of the divide-by-2 clock which is fed into the imager as its reference clock. In this case, the GPIO2 and GPIO3 on the Deserializer can only behave as outputs of the local register on the Deserializer. The GPIO maximum switching rate is up to 66 kHz when configured for communication between Deserializer GPIO to Serializer GPO.

8.3.6 LVCMOS V_{DDIO} Option

1.8-V/2.8-V/3.3-V Serializer inputs are user configurable to provide compatibility with 1.8-V, 2.8-V and 3.3-V system interfaces.

8.3.7 Pixel Clock Edge Select (TRFB / RRFB)

The TRFB/RRFB selects which edge of the Pixel Clock is used. For the SER, this register determines the edge that the data is latched on. If TRFB register is 1, data is latched on the Rising edge of the PCLK. If TRFB register is 0, data is latched on the Falling edge of the PCLK. For the DES, this register determines the edge that the data is strobed on. If RRFB register is 1, data is strobed on the Rising edge of the PCLK. If RRFB register is 0, data is strobed on the falling edge of the PCLK.

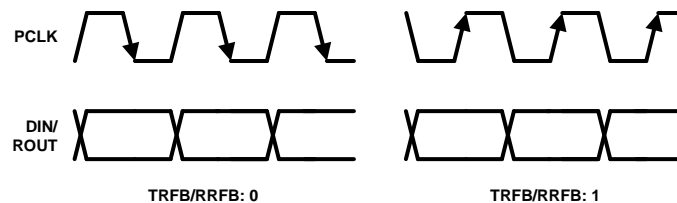

Figure 14. Programmable PCLK Strobe Select

8.3.8 Power Down

The SER has a PDB input pin to ENABLE or power down the device. Enabling PDB on the SER will disable the link to save power. If PDB = HIGH, the SER will operate at its internal default oscillator frequency when the input PCLK stops. When the PCLK starts again, the SER locks to the valid input PCLK and transmit the data to the DES. When PDB = LOW, the high-speed driver outputs are static HIGH. Please refer to [Power-Up Requirements and PDB Pin](#) for power-up requirements.

8.4 Device Functional Modes

8.4.1 DS90UB913A/914A Operation with External Oscillator as Reference Clock

In some applications, the pixel clock that comes from the imager can have jitter which exceeds the tolerance of the DS90UB913A/914A chipsets. In this case, the DS90UB913A-Q1 device should be operated by using an external clock source as the reference clock for the DS90UB913A/914A chipsets. **This is the recommended operating mode.** The external oscillator clock output goes through a divide-by-2 circuit in the DS90UB913A-Q1 Serializer and this divided clock output is used as the reference clock for the imager. The output data and pixel clock from the imager are then fed into the DS90UB913A-Q1 device. Figure 15 shows the operation of the DS90UB913A/914A chipsets while using an external automotive grade oscillator.

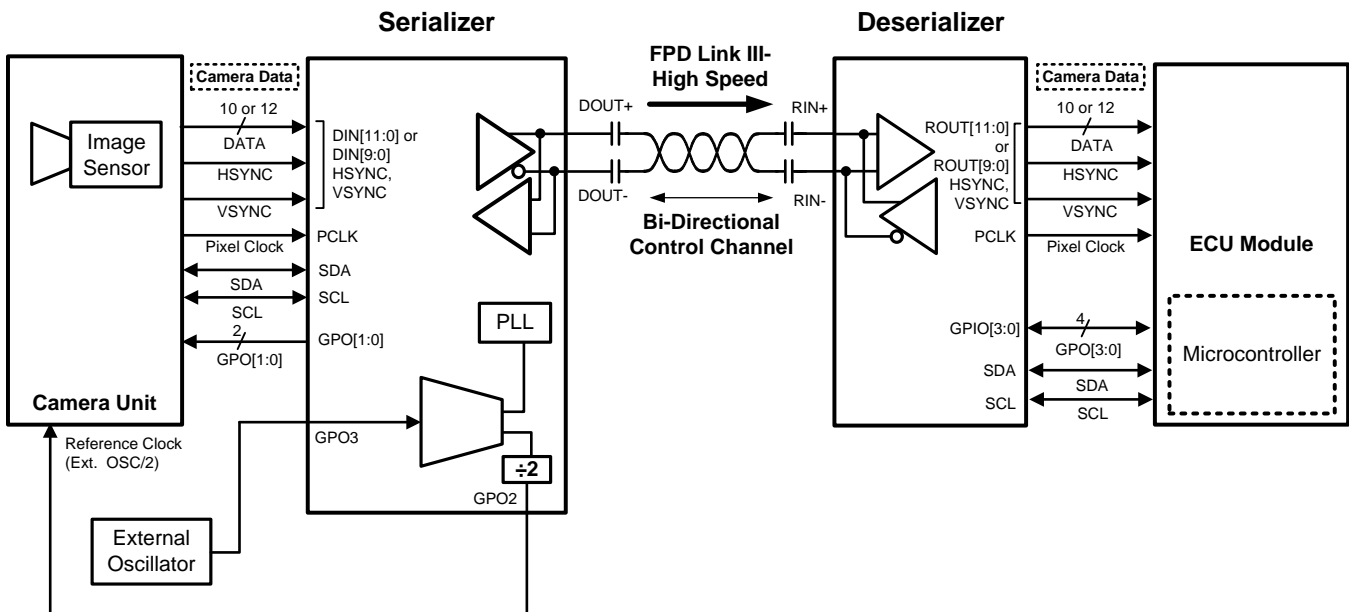

Figure 15. DS90UB913A-Q1/914A-Q1 Operation in the External Oscillator Mode

When the DS90UB913A-Q1 device is operated using an external oscillator, the GPO3 pin on the DS90UB913A-Q1 is the input pin for the external oscillator. In applications where the DS90UB913A-Q1 device is operated from an external oscillator, the divide-by-2 circuit in the DS90UB913A-Q1 device feeds back the divided clock output to the imager device through GPO2 pin. The pixel clock to external oscillator ratios needs to be fixed for the 12-bit high frequency mode and the 10-bit mode. **In the 10-bit mode, the pixel clock frequency divided by the external oscillator frequency must be 2. In the 12-bit high frequency mode, the pixel clock frequency divided by the external oscillator frequency must be 1.5.** For example, if the external oscillator frequency is 48 MHz in the 10-bit mode, the pixel clock frequency of the imager needs to be twice of the external oscillator frequency, that is, 96 MHz. If the external oscillator frequency is 48MHz in the 12-bit high frequency mode, the pixel clock frequency of the imager needs to be 1.5 times of the external oscillator frequency, that is, 72 MHz.

When PCLK signal edge is detected, and 0x03[1] = 0, the DS90UB913A will switch from internal oscillator mode to an external PCLK. Upon removal of PCLK input, the device will switch back into internal oscillator mode. In external oscillator mode, GPO2 and GPO3 on the Serializer cannot act as the output of the input signal coming from GPIO2 or GPIO3 on the Deserializer.

8.4.2 DS90UB913A/914A Operation with Pixel Clock from Imager as Reference Clock

The DS90UB913A/914A chipsets can be operated by using the pixel clock from the imager as the reference clock. Figure 16 shows the operation of the DS90UB913A/914A chipsets using the pixel clock from the imager. If the DS90UB913A-Q1 device is operated using the pixel clock from the imager as the reference clock, then the imager uses an external oscillator as its reference clock. There are 4 GPIOs available in this mode (PCLK from imager mode).

Device Functional Modes (continued)

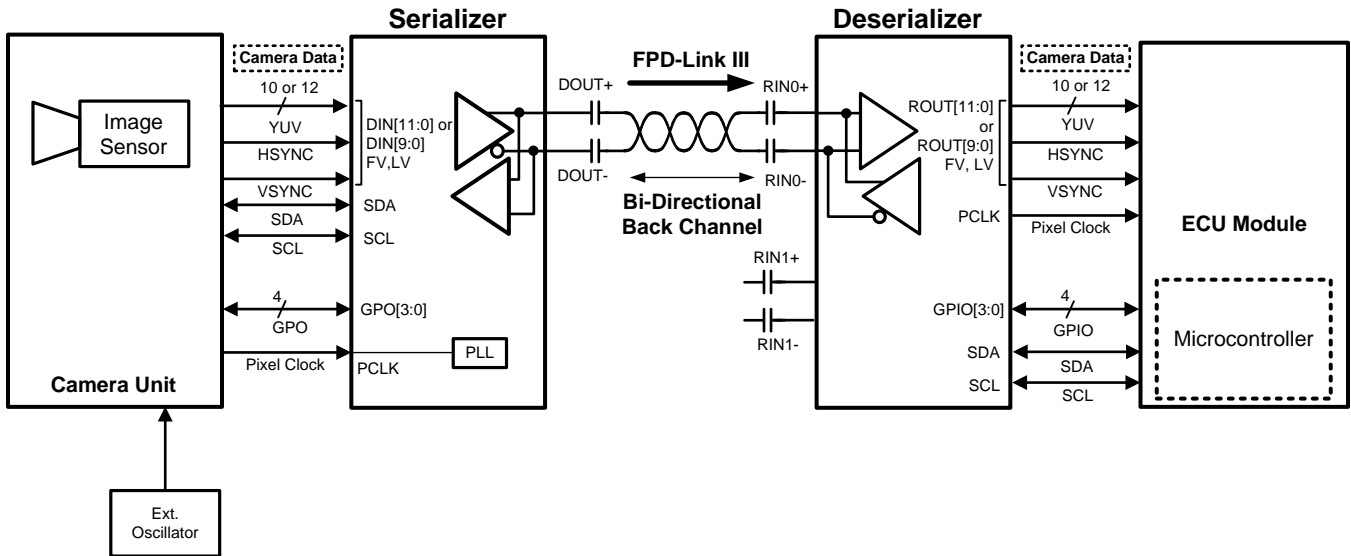

Figure 16. DS90UB913A-Q1/914A-Q1 Operation in PCLK mode

8.4.3 MODE Pin on Serializer

The MODE pin on the Serializer can be configured to select if the DS90UB913A-Q1 device is to be operated from the external oscillator or the PCLK from the imager. The pin must be pulled to V_{DD} (1.8 V, not V_{DDIO}) with a 10-k Ω resistor and a pull-down resistor R_{MODE} of the recommended value to set the modes shown in Figure 17. The recommended maximum resistor tolerance is 1%.

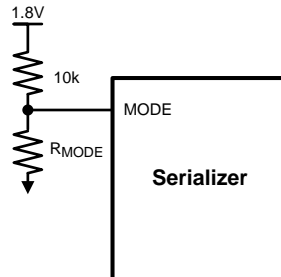

Figure 17. MODE Pin Configuration on DS90UB913A-Q1

Table 1. DS90UB913A-Q1 Serializer MODE Resistor Value

DS90UB913A-Q1 SERIALIZER MODE RESISTOR VALUE	
MODE SELECT	R_{MODE} RESISTOR VALUE (k Ω)
PCLK from imager mode	100
External Oscillator mode	4.7

8.4.4 Internal Oscillator

When a PCLK is not applied to the DS90UB913A, the serializer will establish the FPD-III link using an internal oscillator. During normal operation (not BIST) the frequency of the internal oscillator can be adjusted from DS90UB913A register 0x14[2:1] according to [Table 2](#). In BIST mode, the internal oscillator frequency should only be adjusted from the DS90UB914A. The BIST frequency can be set by either pin strapping ([Table 3](#)) or register ([Table 4](#)). In BIST DS90UB913A register 0x14[2:1] is automatically loaded from the DS90UB914A through the bi-directional control channel.

Table 2. Clock Sources for Forward Channel Frame on the Serializer During Normal Operation

DS90UB913A-Q1 Reg 0x14 [2:1]	10-BIT MODE (MHz)	12-BIT HIGH-FREQUENCY MODE (MHz)	12-BIT LOW-FREQUENCY MODE (MHz)
00	50	37.5	25
01	100	75	50
10	50	37.5	25
11	25	-	-

8.4.5 Built In Self Test

An optional At-Speed Built In Self Test (BIST) feature supports the testing of the high-speed serial link and low-speed back channel. This is useful in the prototype stage, equipment production, and in-system test and also for system diagnostics.

8.4.6 BIST Configuration and Status

The chipset can be programmed into BIST mode using either pins or registers on the DES only. By default, BIST configuration is controlled through pins. BIST can be configured via registers using BIST Control register (0x24). Pin-based configuration is defined as follows:

- BISTEN = HIGH: Enable the BIST mode, BISTEN = LOW: Disable the BIST mode.
- Deserializer GPIO0 and GPIO1: Defines the BIST clock source (PCLK vs. various frequencies of internal OSC)

Table 3. BIST Pin Configuration

DESERIALIZER GPIO[0:1]	OSCILLATOR SOURCE	BIST FREQUENCY (MHz)
00	External PCLK	PCLK or External Oscillator
01	Internal	~50
10	Internal	~25

Table 4. BIST Register Configuration

DS90UB914A-Q1 Reg 0x24 [2:1]	10-BIT MODE	12-BIT HIGH-FREQUENCY MODE	12-BIT LOW-FREQUENCY MODE
00	PCLK	PCLK	PCLK
01	100 MHz	75 MHz	50 MHz
10	50 MHz	37.5 MHz	25 MHz
11	25 MHz	-	-

BIST mode provides various options for the PCLK source. Either external pins (GPIO0 and GPIO1) or registers can be used to program the BIST to use external PCLK or various OSC frequencies. Refer to [Table 3](#) for pin settings. The BIST status can be monitored real-time on the PASS pin. For every frame with error(s), the PASS pin toggles low for one-half PCLK period. If two consecutive frames have errors, PASS will toggle twice to allow counting of frames with errors. Once the BIST is done, the PASS pin reflects the pass/fail status of the last BIST run only for one PCLK cycle. The status can also be read through I2C for the number of frames in errors. BIST status register retains results until it is reset by a new BIST session or a device reset. To evaluate BIST in external oscillator mode, both the external oscillator and PCLK need to be present. For all practical purposes, the BIST status can be monitored from the BIST Error Count register 0x25 on the DS90UB914A Deserializer.

8.4.7 Sample BIST Sequence

Step 1. For the DS90UB913A/914A FPD-Link III chipset, BIST Mode is enabled via the BISTEN pin of DS90UB914A-Q1 FPD-Link III deserializer. The desired clock source is selected through the deserializer GPIO0 and GPIO1 pins as shown in [Table 3](#).

Step 2. The DS90UB913A-Q1 Serializer BIST pattern is enabled through the back channel. The BIST pattern is sent through the FPD-Link III to the deserializer. Once the serializer and deserializer are in the BIST mode and the deserializer acquires Lock, the PASS pin of the deserializer goes high and BIST starts checking FPD-Link III serial stream. If an error in the payload is detected, the PASS pin will switch low for one half of the clock period. During the BIST test, the PASS output can be monitored and counted to determine the payload error rate.

Step 3. To stop the BIST mode, the deserializer BISTEN pin is set LOW. The deserializer stops checking the data. The final test result is not maintained on the PASS pin. To monitor the BIST status, check the BIST Error Count register, 0x25 on the Deserializer.

Step 4. The link returns to normal operation after the deserializer BISTEN pin is low. [Figure 19](#) shows the waveform diagram of a typical BIST test for two cases. Case 1 is error free, and Case 2 shows one with multiple errors. In most cases, it is difficult to generate errors due to the robustness of the link (differential data transmission etc.), thus they may be introduced by greatly extending the cable length, faulting the interconnect, or by reducing signal condition enhancements (Rx equalization).

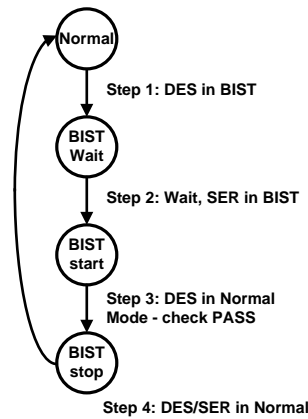

Figure 18. AT-Speed BIST System Flow Diagram

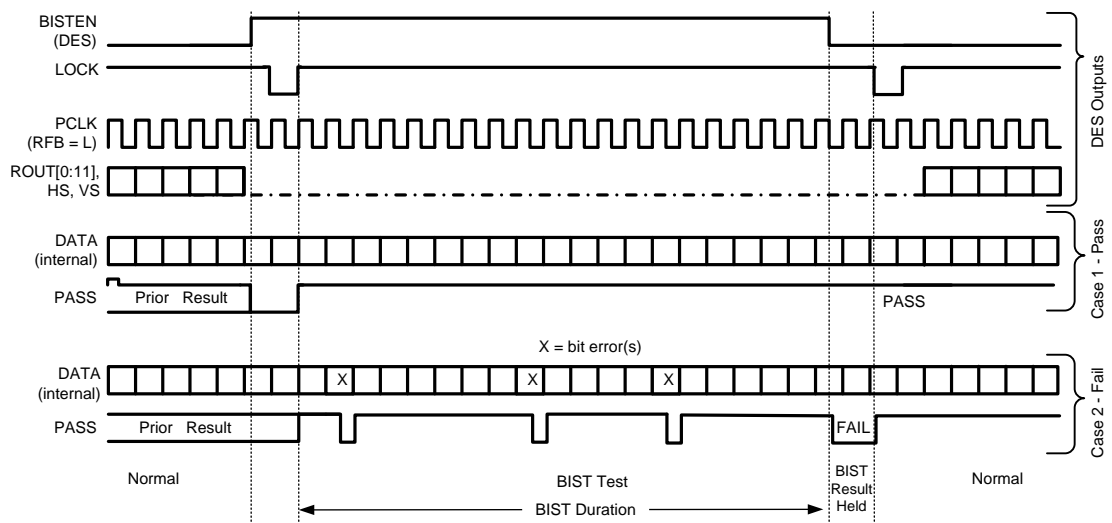

Figure 19. BIST Timing Diagram

8.5 Programming

8.5.1 Programmable Controller

An integrated I2C slave controller is embedded in the DS90UB913A-Q1 Serializer. It must be used to configure the extra features embedded within the programmable registers or it can be used to control the set of programmable GPIOs.

8.5.2 Description of Bidirectional Control Bus and I2C Modes

The I2C-compatible interface allows programming of the DS90UB913A-Q1, DS90UB914A-Q1, or an external remote device (such as image sensor) through the bidirectional control channel. Register programming transactions to/from the DS90UB913A-Q1/914A-Q1 chipset are employed through the clock (SCL) and data (SDA) lines. These two signals have open drain I/Os and both lines must be pulled-up to V_{DDIO} by an external resistor. Pullup resistors or current sources are required on the SCL and SDA busses to pull them high when they are not being driven low. A logic LOW is transmitted by driving the output low. Logic HIGH is transmitted by releasing the output and allowing it to be pulled-up externally. The appropriate pullup resistor values will depend upon the total bus capacitance and operating speed. The DS90UB913A I2C bus data rate supports up to 400 kbps according to I2C fast mode specifications.

For further description of general I2C communication, please refer to application note *Understanding the I2C Bus (SLVA704)*. For more information on choosing appropriate pullup resistor values, please refer to application note *I2C Bus Pullup Resistor Calculation (SLVA689)*.

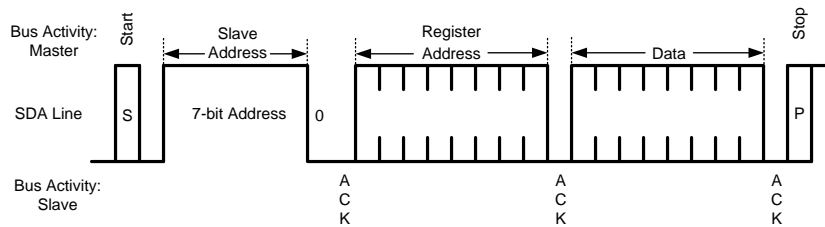

Figure 20. Write Byte

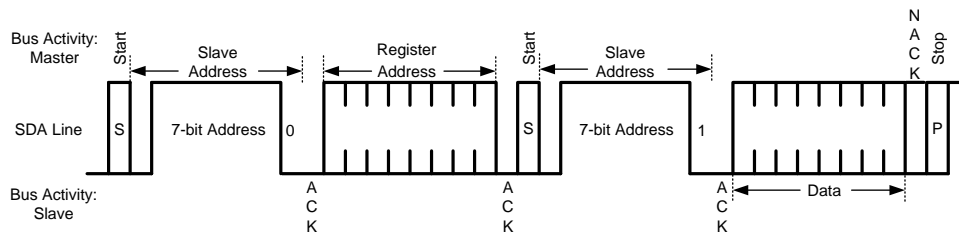

Figure 21. Read Byte

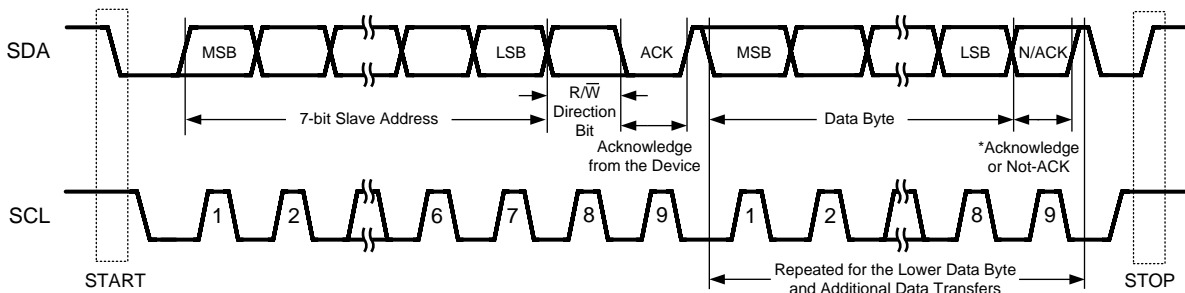

Figure 22. Basic Operation

Programming (continued)

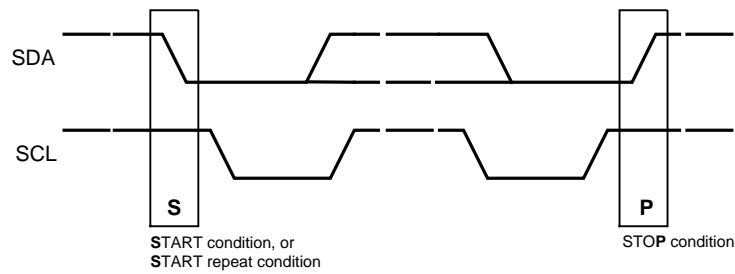

Figure 23. Start and Stop Conditions

8.5.3 I2C Pass-Through

I2C pass-through provides a way to access remote devices at the other end of the FPD-Link III interface. This option is used to determine if an I2C instruction is transferred over to the remote I2C bus. For example, when the I2C master is connected to the deserializer and I2C pass-through is enabled on the deserializer, any I2C traffic targeted for the remote serializer or remote slave will be allowed to pass through the deserializer to reach those respective devices.

See Figure 24 for an example of this function and refer to application note: *I2C over DS90UB913/4 FPD-Link III with Bidirectional Control Channel* (SNLA222).

If master controller transmits I2C transaction for address 0xA0, the DES A with I2C pass-through enabled will transfer I2C commands to remote Camera A. The DES B with I2C pass-through disabled, any I2C commands will NOT be passed on the I2C bus to Camera B.

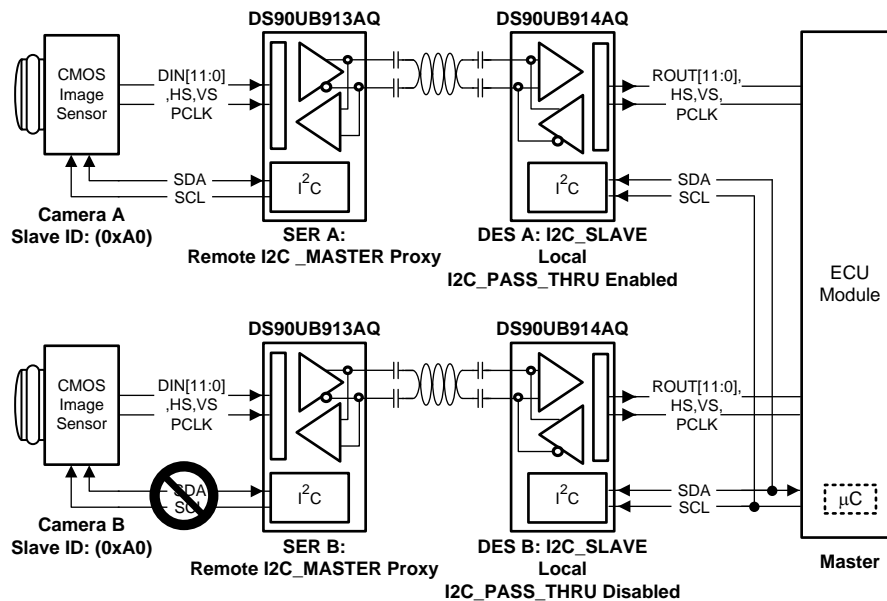

Figure 24. I2C Pass-Through

8.5.4 Slave Clock Stretching

The I2C-compatible interface allows programming of the DS90UB913A-Q1, DS90UB914A-Q1, or an external remote device (such as image sensor) through the bidirectional control. To communicate and synchronize with remote devices on the I2C bus through the bidirectional control channel/MCU, **the chipset utilizes bus clock stretching (holding the SCL line low) during data transmission**; where the I2C slave pulls the SCL line low on the 9th clock of every I2C transfer (before the ACK signal). The slave device will not control the clock and only stretches it until the remote peripheral has responded. The I2C master must support clock stretching to operate with the DS90UB913A/914A chipset.

Programming (continued)

8.5.5 ID[x] Address Decoder on the Serializer

The ID[x] pin on the Serializer is used to decode and set the physical slave address of the Serializer (I2C only) to allow up to five devices on the bus connected to the Serializer using only a single pin. The pin sets one of the 6 possible addresses for each Serializer device. The pin must be pulled to V_{DD} (1.8 V, not V_{DDIO}) with a 10-k Ω resistor and a pull-down resistor (R_{ID}) of the recommended value to set the physical device address. The recommended maximum resistor tolerance is 1%.

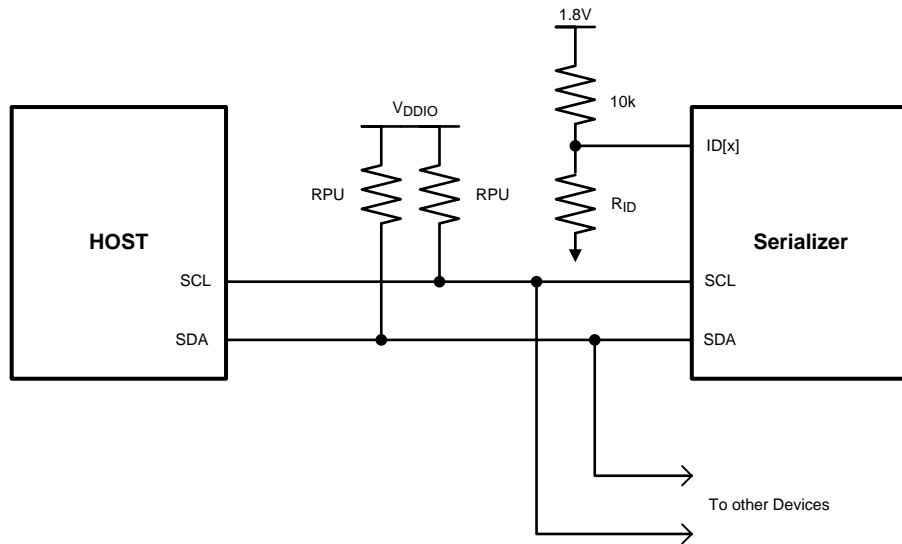

Figure 25. ID[x] Address Decoder on the Serializer

Table 5. ID[x] Resistor Value for DS90UB913A-Q1 Serializer

ID[x] RESISTOR VALUE — DS90UB913A-Q1 SERIALIZER		
Resistor RID (k Ω) (1% Tolerance)	Address 7'b	Address 8'b 0 appended (WRITE)
0	0x58	0xB0
2	0x59	0xB2
4.7	0x5A	0xB4
8.2	0x5B	0xB6
14	0x5C	0xB8
100	0x5D	0xBA

8.5.6 Multiple Device Addressing

Some applications require multiple camera devices with the same fixed address to be accessed on the same I2C bus. The DS90UB913A provides slave ID matching/aliasing to generate different target slave addresses when connecting more than two identical devices together on the same bus. This allows the slave devices to be independently addressed. Each device connected to the bus is addressable through a unique ID by programming of the Slave alias register on Deserializer. This will remap the Slave alias address to the target SLAVE_ID address; up to 8 ID Alias's are supported in sensor mode when slaves are attached to the DS90UB913A serializer. In display mode, when the external slaves are at the deserializer the DS90UB913A supports one ID Alias. The ECU Controller must keep track of the list of I2C peripherals in order to properly address the target device.

See [Figure 26](#) for an example of this function.

- ECU is the I2C master and has an I2C master interface
- The I2C interfaces in DES A and DES B are both slave interfaces
- The I2C protocol is bridged from DES A to SER A and from DES B to SER B

- The I2C interfaces in SER A and SER B are both master interfaces

If master controller transmits I2C slave 0xA0, DES A (address 0xC0), with pass through enabled, will forward the transaction to remote Camera A. If the controller transmits slave address 0xA4, the DES B 0xC2 will recognize that 0xA4 is mapped to 0xA0 and will be transmitted to the remote Camera B. If controller sends command to address 0xA6, the DES B (address 0xC2), with pass through enabled, will forward the transaction to slave device 0xA2.

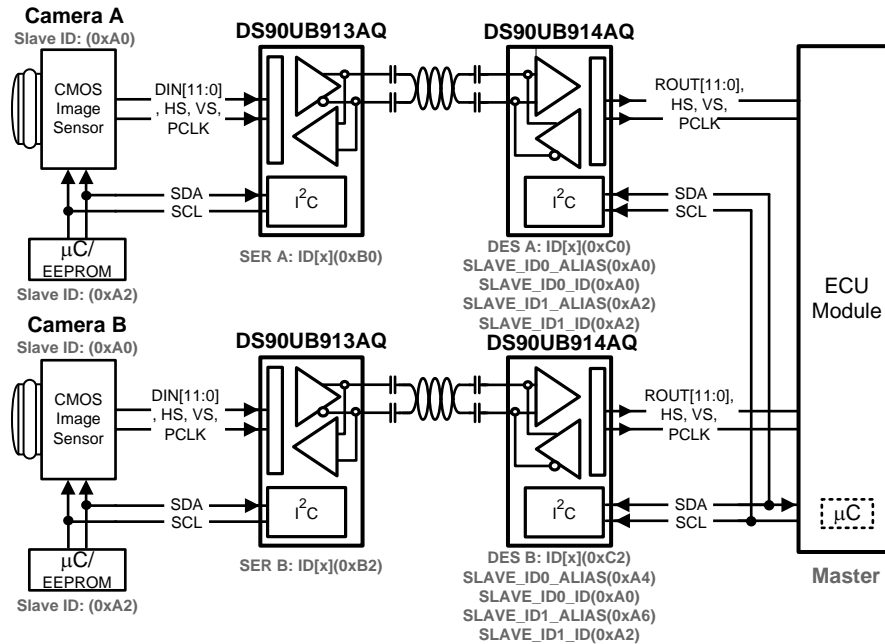

Figure 26. Multiple Device Addressing

8.6 Register Maps

Table 6. DS90UB913A-Q1 Control Registers⁽¹⁾

Addr (Hex)	Name	Bits	Field	R/W	Default	Description
0x00	I2C Device ID	7:1	DEVICE ID	RW	0xB0'h (1011_0000'b)	7-bit address of Serializer; 0x58'h. (101_1000'b) default.
		0	Serializer ID SEL			0: Device ID is from ID[x]. 1: Register I2C Device ID overrides ID[x].
0x01	Power and Reset	7	RSVD			Reserved.
		6	RDS	RW	0	Digital Output Drive Strength. 1: High Drive Strength. 0: Low Drive Strength.
		5	V _{DDIO} Control	RW	1	Auto Voltage Control. 1: Enable. 0: Disable.
		4	V _{DDIO} MODE	RW	1	V _{DDIO} Voltage set. 1: V _{DDIO} = 3.3 V. 0: V _{DDIO} = 1.8 V.
		3	ANAPWDN	RW	0	This register can be set only through local I2C access. 1: Analog power down. Powers down the analog block in the Serializer. 0: No effect.
		2	RSVD			Reserved.
		1	DIGITAL RESET1	RW	0	1: Resets the digital block except for register values. Does not affect device I2C Bus or Device ID. This bit is self-clearing. 0: Normal Operation.
0	DIGITAL RESET0	RW	0	1: Digital Reset, resets the entire digital block including all register values. This bit is self-clearing. 0: Normal Operation.		
0x02	Reserved.					
0x03	General Configuration	7	RX CRC Checker Enable	RW	1	Back-channel CRC Checker Enable. 1: Enable. 0: Disable.
		6	TX Parity Generator Enable	RW	1	Forward channel Parity Generator Enable. 1: Enable. 0: Disable.
		5	CRC Error Reset	RW	0	Clear CRC Error Counters. This bit is NOT self-clearing. 1: Clear Counters. 0: Normal Operation.
		4	I2C Remote Write Auto Acknowledge	RW	0	Automatically Acknowledge I2C Remote Write. The mode works when the system is LOCKed. 1: Enable: When enabled, I2C writes to the Deserializer (or any remote I2C Slave, if I2C PASS ALL is enabled) are immediately acknowledged without waiting for the Deserializer to acknowledge the write. The accesses are then remapped to address specified in 0x06. 0: Disable.
		3	I2C Pass-Through All	RW	0	1: Enable Forward Control Channel pass-through of all I2C accesses to I2C IDs that do not match the Serializer I2C ID. The I2C accesses are then remapped to address specified in register 0x06. 0: Enable Forward Control Channel pass-through only of I2C accesses to I2C IDs matching either the remote Deserializer ID or the remote I2C IDs.
2	I2C Pass-Through	RW	1	I2C Pass-Through Mode. 1: Pass-Through Enabled. DES Alias 0x07 and Slave Alias 0x09. 0: Pass-Through Disabled.		

(1) To ensure optimum device functionality, It is recommended to NOT write to any RESERVED registers.

Register Maps (continued)
Table 6. DS90UB913A-Q1 Control Registers⁽¹⁾ (continued)

Addr (Hex)	Name	Bits	Field	R/W	Default	Description
0x03	General Configuration	1	OV_CLK2PLL	RW	0	1: Enabled : When enabled this register overrides the clock to PLL mode (External Oscillator mode or Direct PCLK mode) defined through MODE pin and allows selection through register 0x35 in the Serializer. 0: Disabled : When disabled, Clock to PLL mode (External Oscillator mode or Direct PCLK mode) is defined through MODE pin on the Serializer.
		0	TRFB	RW	1	Pixel Clock Edge Select. 1: Parallel Interface Data is strobed on the Rising Clock Edge. 0: Parallel Interface Data is strobed on the Falling Clock Edge.
0x04	Reserved.					
0x05	Mode Select	7	RSVD			Reserved.
		6	RSVD			Reserved.
		5	MODE_OVERRIDE	RW	0	Allows overriding mode select bits coming from back-channel. 1: Overrides MODE select bits. 0: Does not override MODE select bits.
		4	MODE_UP_TO_DATE	R	0	1: Status of mode select from Deserializer is up-to-date. 0: Status is NOT up-to-date.
		3	Pin_MODE_12-bit High Frequency	R	0	1: 12-bit high frequency mode is selected. 0: 12-bit high frequency mode is not selected.
		2	Pin_MODE_10-bit mode	R	0	1: 10-bit mode is selected. 0: 10-bit mode is not selected.
		1:0	RSVD			Reserved.
0x06	DES ID	7:1	Deserializer Device ID	RW	0x00'h	7-bit Deserializer Device ID Configures the I2C Slave ID of the remote Deserializer . A value of 0 in this field disables I2C access to the remote Deserializer . This field is automatically configured by the Bidirectional Control Channel once RX Lock has been detected. Software may overwrite this value, but should also assert the FREEZE DEVICE ID bit to prevent overwriting by the Bidirectional Control Channel.
		0	Freeze Device ID	RW	0	1: Prevents auto-loading of the Deserializer Device ID by the bidirectional control channel. The ID will be frozen at the value written. 0: Update.
0x07	DES Alias	7:1	Deserializer ALIAS ID	RW	0x00'h	7-bit Remote Deserializer Device Alias ID Configures the decoder for detecting transactions designated for an I2C Deserializer device. The transaction will be remapped to the address specified in the DES ID register. A value of 0 in this field disables access to the remote Deserializer .
		0	RSVD			Reserved.
0x08	SlaveID	7:1	SLAVE ID	RW	0x00'h	7-bit Remote Slave Device ID Configures the physical I2C address of the remote I2C Slave device attached to the remote Deserializer . If an I2C transaction is addressed to the Slave Alias ID, the transaction will be remapped to this address before passing the transaction across the Bidirectional Control Channel to the Deserializer and then to remote slave. A value of 0 in this field disables access to the remote I2C slave.
		0	RSVD			Reserved.

Register Maps (continued)
Table 6. DS90UB913A-Q1 Control Registers⁽¹⁾ (continued)

Addr (Hex)	Name	Bits	Field	R/W	Default	Description
0x09	Slave Alias	7:1	SLAVE ALIAS ID	RW	0x00'h	7-bit Remote Slave Device Alias ID Configures the decoder for detecting transactions designated for an I2C Slave device attached to the remote Deserializer . The transaction will be remapped to the address specified in the Slave ID register. A value of 0 in this field disables access to the remote I2C Slave.
		0	RSVD			Reserved.
0x0A	CRC Errors	7:0	CRC Error Byte 0	R	0x00'h	Number of back-channel CRC errors during normal operation. Least Significant byte.
0x0B	CRC Errors	7:0	CRC Error Byte 1	R	0x00'h	Number of back-channel CRC errors during normal operation. Most Significant byte.
0x0C	General Status	7:5	Rev-ID	R	0x0'h	Revision ID. 0x0: Production Revision ID.
		4	RX Lock Detect	R	0	1: RX LOCKED. 0: RX not LOCKED.
		3	BIST CRC Error Status	R	0	1: CRC errors in BIST mode. 0: No CRC errors in BIST mode.
		2	PCLK Detect	R	0	1: Valid PCLK detected. 0: Valid PCLK not detected.
		1	DES Error	R	0	1: CRC error is detected during communication with Deserializer. This bit is cleared upon loss of link or assertion of CRC ERROR RESET in register 0x04. 0: No effect.
		0	LINK Detect	R	0	1: Cable link detected. 0: Cable link not detected. This includes any of the following faults: — Cable Open. — '+' and '-' shorted. — Short to GND. — Short to battery.
0x0D	GPO[0] and GPO[1] Configuration	7	GPO1 Output Value	RW	0	Local GPIO Output Value. This value is output on the GPIO pin when the GPIO function is enabled. The local GPIO direction is Output, and remote GPIO control is disabled.
		6	GPO1 Remote Enable	RW	1	Remote GPIO Control. 1: Enable GPIO control from remote Deserializer. The GPIO pin needs to be an output, and the value is received from the remote Deserializer. 0: Disable GPIO control from remote Deserializer.
		5	RSVD			Reserved.
		4	GPO1 Enable	RW	1	1: GPIO enable. 0: Tri-state.
		3	GPO0 Output Value	RW	0	Local GPIO Output Value. This value is output on the GPIO pin when the GPIO function is enabled. The local GPIO direction is Output, and remote GPIO control is disabled.
		2	GPO0 Remote Enable	RW	1	Remote GPIO Control. 1: Enable GPIO control from remote Deserializer. The GPIO pin needs to be an output, and the value is received from the remote Deserializer. 0: Disable GPIO control from remote Deserializer.
		1	RSVD			Reserved.
		0	GPO0 Enable	RW	1	1: GPIO enable. 0: Tri-state.

Register Maps (continued)
Table 6. DS90UB913A-Q1 Control Registers⁽¹⁾ (continued)

Addr (Hex)	Name	Bits	Field	R/W	Default	Description
0x0E	GPO[2] and GPO[3] Configuration	7	GPO3 Output Value	RW	0	Local GPIO Output Value. This value is output on the GPIO pin when the GPIO function is enabled. The local GPIO direction is Output, and remote GPIO control is disabled.
		6	GPO3 Remote Enable	RW	0	Remote GPIO Control. 1: Enable GPIO control from remote Deserializer. The GPIO pin needs to be an output, and the value is received from the remote Deserializer. 0: Disable GPIO control from remote Deserializer.
		5	GPO3 Direction	RW	1	1: Input. 0: Output.
		4	GPO3 Enable	RW	1	1: GPIO enable. 0: Tri-state.
		3	GPO2 Output Value	RW	0	Local GPIO Output Value. This value is output on the GPIO pin when the GPIO function is enabled. The local GPIO direction is Output, and remote GPIO control is disabled.
		2	GPO2 Remote Enable	RW	1	Remote GPIO Control. 1: Enable GPIO control from remote Deserializer. The GPIO pin needs to be an output, and the value is received from the remote Deserializer. 0: Disable GPIO control from remote Deserializer.
		1	RSVD			Reserved.
		0	GPO2 Enable	RW	1	1: GPIO enable. 0: Tri-state.
0x0F	I2C Master Config	7:5	RSVD			Reserved.
		4:3	SDA Output Delay	RW	00	SDA Output Delay This field configures output delay on the SDA output. Setting this value will increase output delay in units of 50ns. Nominal output delay values for SCL to SDA are: 00: ~350 ns 01: ~400 ns 10: ~450 ns 11: ~500 ns
		2	Local Write Disable	RW	0	Disable Remote Writes to Local Registers Setting this bit to a 1 will prevent remote writes to local device registers from across the control channel. This prevents writes to the Serializer registers from an I2C master attached to the Deserializer. Setting this bit does not affect remote access to I2C slaves at the Serializer.
		1	I2C Bus Timer Speed up	RW	0	Speed up I2C Bus Watchdog Timer. 1: Watchdog Timer expires after approximately 50 microseconds. 0: Watchdog Timer expires after approximately 1 second.
		0	I2C Bus Timer Disable	RW	0	1. Disable I2C Bus Watchdog Timer When the I2C Watchdog Timer may be used to detect when the I2C bus is free or hung up following an invalid termination of a transaction. If SDA is high and no signaling occurs for approximately 1 second, the I2C bus will assumed to be free. If SDA is low and no signaling occurs, the device will attempt to clear the bus by driving 9 clocks on SCL. 0: No effect.

Register Maps (continued)
Table 6. DS90UB913A-Q1 Control Registers⁽¹⁾ (continued)

Addr (Hex)	Name	Bits	Field	R/W	Default	Description
0x10	I2C Control	7	RSVD			Reserved.
		6:4	SDA Hold Time	RW	0x1'h	Internal SDA Hold Time. This field configures the amount of internal hold time provided for the SDA input relative to the SCL input. Units are 50 ns.
		3:0	I2C Filter Depth	RW	0x7'h	I2C Glitch Filter Depth. This field configures the maximum width of glitch pulses on the SCL and SDA inputs that will be rejected. Units are 10 ns.
0x11	SCL High Time	7:0	SCL High Time	RW	0x82'h	I2C Master SCL High Time This field configures the high pulse width of the SCL output when the Serializer is the Master on the local I2C bus. Units are 50 ns for the nominal oscillator clock frequency. The default value is set to provide a minimum (4 μ s + 1 μ s of rise time for cases where rise time is very fast) SCL high time with the internal oscillator clock running at 26 MHz rather than the nominal 20 MHz.
0x12	SCL LOW Time	7:0	SCL Low Time	RW	0x82'h	I2C SCL Low Time This field configures the low pulse width of the SCL output when the Serializer is the Master on the local I2C bus. This value is also used as the SDA setup time by the I2C Slave for providing data prior to releasing SCL during accesses over the Bidirectional Control Channel. Units are 50 ns for the nominal oscillator clock frequency. The default value is set to provide a minimum (4.7 μ s + 0.3 μ s of fall time for cases where fall time is very fast) SCL low time with the internal oscillator clock running at 26MHz rather than the nominal 20MHz.
0x13	General Purpose Control	7:0	GPCR[7:0]	RW	0x00'h	1: High. 0: Low.
0x14	BIST Control	7:3	RSVD			Reserved.
		2:1	Clock Source	RW	0x0'h	Allows choosing different OSC clock frequencies for forward channel frame. OSC Clock Frequency in Functional Mode when OSC mode is selected or when the selected clock source is not present, for example, missing PCLK/ External Oscillator. See Table 2 for oscillator clock frequencies when PCLK/ External Clock is missing.
		0	RSVD			Reserved.
0x15 - 0x1D	Reserved.					
0x1E	BCC Watchdog Control	7:1	BCC Watchdog Timer	RW	0x7F'h (111_1111'b)	The watchdog timer allows termination of a control channel transaction if it fails to complete within a programmed amount of time. This field sets the Bidirectional Control Channel Watchdog Timeout value in units of 2 ms. This field should not be set to 0.
		0	BCC Watchdog Timer Disable	RW	0	1: Disables BCC Watchdog Timer operation. 0: Enables BCC Watchdog Timer operation.
0x1F - 0x29	Reserved.					
0x2A	CRC Errors	7:0	BIST Mode CRC Errors Count	R	0x00'h	Number of CRC Errors in the back channel when in BIST mode.
0x2B - 0x2C	Reserved.					

Register Maps (continued)
Table 6. DS90UB913A-Q1 Control Registers⁽¹⁾ (continued)

Addr (Hex)	Name	Bits	Field	R/W	Default	Description
0x2D	Inject Forward Channel Error	7	Force Forward Channel Error	RW	0	1: Forces 1 (one) error over forward channel frame in normal operating mode. Self clearing bit. 0: No error.
		6:0	Force BIST Error	RW	0x00'h	N: Forces N number of errors in BIST mode. This register MUST be set BEFORE BIST mode is enabled. BIST Error Count Register on the deserializer (i.e. 0x25 on 914A device) should be read AFTER BIST mode is disabled for the correct number of errors incurred while in BIST mode. 0: No error.
0x2E - 0x34	Reserved.					
0x35	PLL Clock Overwrite	7:4	RSVD			Reserved.
		3	PIN_LOCK to External Oscillator	RW	0	Status of mode select pin. 1: Indicates External Oscillator mode is selected by mode-resistor. 0: External Oscillator mode is not selected by mode-resistor.
		2	RSVD			Reserved.
		1	LOCK to External Oscillator	RW	0	Affects only when 0x03[1]=1 (OV_CLK2PLL) and 0x35[0]=0. 1: Routes GPO3 directly to PLL. 0: Allows PLL to lock to PCLK.
		0	LOCK2OSC	RW	1	Affects only when 0x03[1]=1 (OV_CLK2PLL). 1: Allows internal OSC clock to feed into PLL. 0: Allows PLL to lock to either PCLK or external clock from GPO3.

9 Application and Implementation

NOTE

Information in the following applications sections is not part of the TI component specification, and TI does not warrant its accuracy or completeness. TI's customers are responsible for determining suitability of components for their purposes. Customers should validate and test their design implementation to confirm system functionality.

9.1 Application Information

The DS90UB913A was designed as a serializer to support automotive camera designs. Automotive cameras are often located in remote positions such as bumpers or trunk lids, and a major component of the system cost is the wiring. For this reason it is desirable to minimize the wiring to the camera. This chipset allows the video data, along with a bidirectional control channel, and power to all be sent over a single coaxial cable. The chipset is also able to transmit over STP and is pin-to-pin/backwards compatible with the DS90UB913Q.

9.1.1 Power Over Coax

See application report [Sending Power over Coax in DS90UB913A Designs](#) for more details.

9.1.2 Power-Up Requirements and PDB Pin

The PDB pin on the device must be ramped after the V_{DDIO} and V_{DD_n} supplies have reached their required operating voltage levels. It is recommended to assert PDB = HIGH with an RC filter network to help ensure proper sequencing of the PDB pin after settling of the power supplies. Please refer to [Power Down](#) for device operation when powered down.

Common applications will tie the V_{DDIO} and V_{DD_n} supplies to the same power source of 1.8V typically. This is an acceptable method for ramping the V_{DDIO} and V_{DD_n} supplies. The main constraint here is that the V_{DD_n} supply does not lead in ramping before the V_{DDIO} system supply. This is noted in Figure 27 with the requirement of $t_1 \geq 0$.

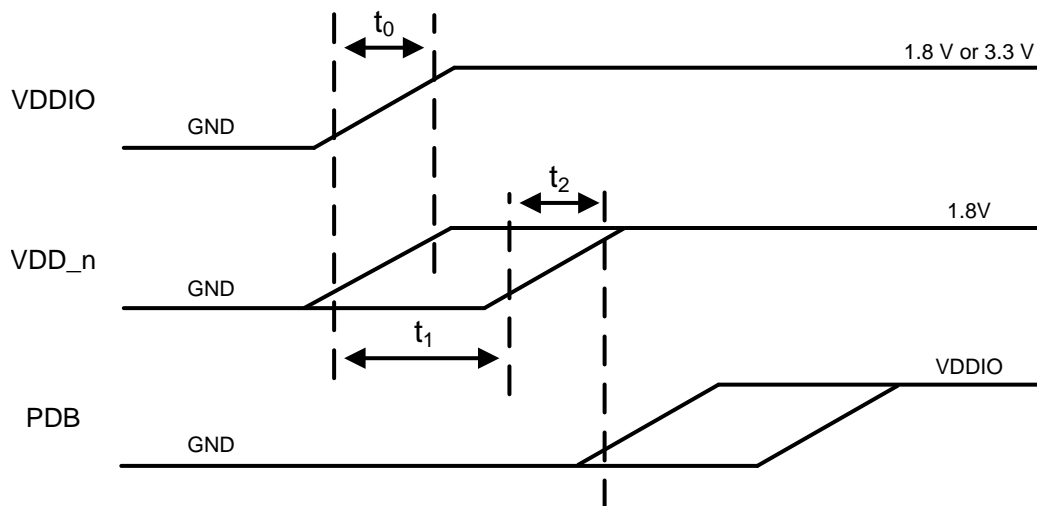

Figure 27. Suggested Power-Up Sequencing

Application Information (continued)
Table 7. Power-Up Sequencing Constraints for DS90UB913A-Q1

Symbol	Description	Test Conditions	Min	Typ	Max	Units
t_0	V_{DDIO} Rise Time	V_{IL} to V_{IH} on rising edge; Monotonic signal ramp is required	0.05		1.5	ms
t_1	V_{DDIO} to V_{DD_n} Delay	V_{IL} of rising edge (V_{DDIO}) to V_{IL} of rising edge (V_{DD_n})	0			ms
t_2	V_{DD_n} Rise Time	$V_{PDB} < V_{IL_VDDIO}$; V_{IL} to V_{IH} on rising edge; Monotonic signal ramp is required	0.05		1.5	ms

9.1.3 AC Coupling

The SER/DES supports only AC-coupled interconnects through an integrated DC-balanced decoding scheme. External AC-coupling capacitors must be placed in series in the FPD-Link III signal path as illustrated in Figure 28. For applications utilizing single-ended 50-Ω coaxial cable, the unused data pin (DOUT–, RIN–) should utilize a 0.047-μF capacitor and should be terminated with a 50-Ω resistor.

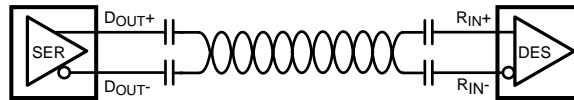

Figure 28. AC-Coupled Connection (STP)

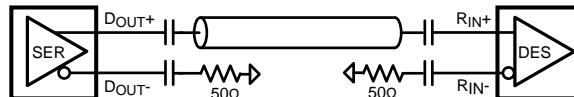

Figure 29. AC-Coupled Connection (Coaxial)

For high-speed FPD-Link III transmissions, the smallest available package should be used for the AC coupling capacitor. This will help minimize degradation of signal quality due to package parasitics. The I/O's require a 0.1-μF AC coupling capacitors to the line.

9.1.4 Transmission Media

The DS90UB913A/914A chipset is intended to be used in a point-to-point configuration through a shielded coaxial cable. The Serializer and Deserializer provide internal termination to minimize impedance discontinuities. The interconnect (cable and connectors) should have a differential impedance of 100 Ω, or a single-ended impedance of 50 Ω. The maximum length of cable that can be used is dependent on the quality of the cable (gauge, impedance), connector, board (discontinuities, power plane), the electrical environment (for example, power stability, ground noise, input clock jitter, PCLK frequency, etc). The resulting signal quality at the receiving end of the transmission media may be assessed by monitoring the differential eye opening of the serial data stream. A differential probe should be used to measure across the termination resistor at the CMLOUTP/N pins.

Please refer to [Cable Requirements for the DS90UB913A & DS90UB914A](#) or contact TI for a channel specification regarding cable loss parameters and further details on adaptive equalizer loss compensation.

9.2 Typical Applications

9.2.1 Coax Application

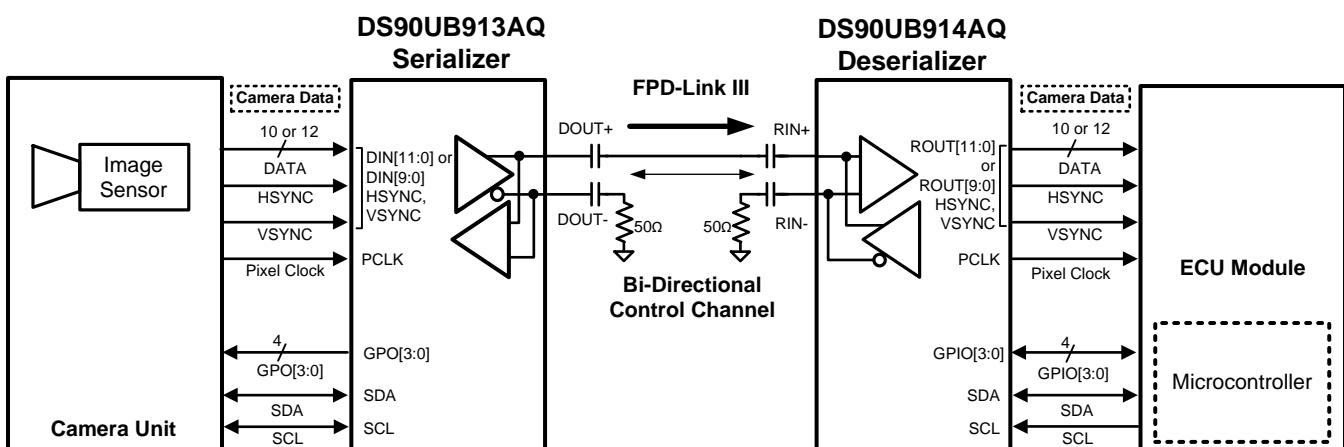

Figure 30. Coax Application Block Diagram

Typical Applications (continued)

9.2.1.1 Design Requirements

For the typical coax design applications, use the following as input parameters:

Table 8. Coax Design Parameters

DESIGN PARAMETER	EXAMPLE VALUE
V _{DDIO}	1.8 V, 2.8 V, or 3.3 V
V _{DD_n}	1.8 V
AC Coupling Capacitors for DOUT±	0.1 μF, 0.047 μF (For the unused data pin, DOUT–)
PCLK Frequency	50 MHz (12-bit low frequency), 75 MHz (12-bit high frequency), 100 MHz (10-bit)

9.2.1.2 Detailed Design Procedure

Figure 31 shows the typical connection of a DS90UB913A-Q1 Serializer using a coax interface.

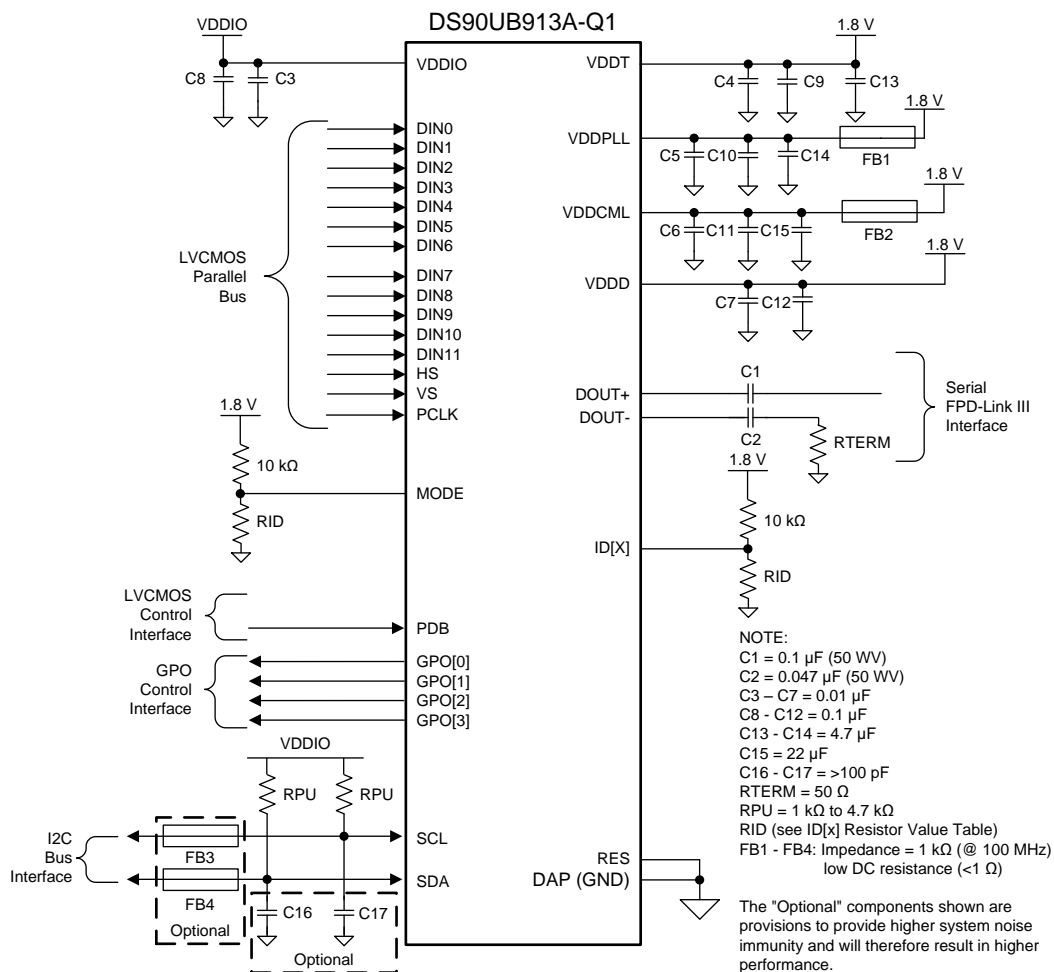
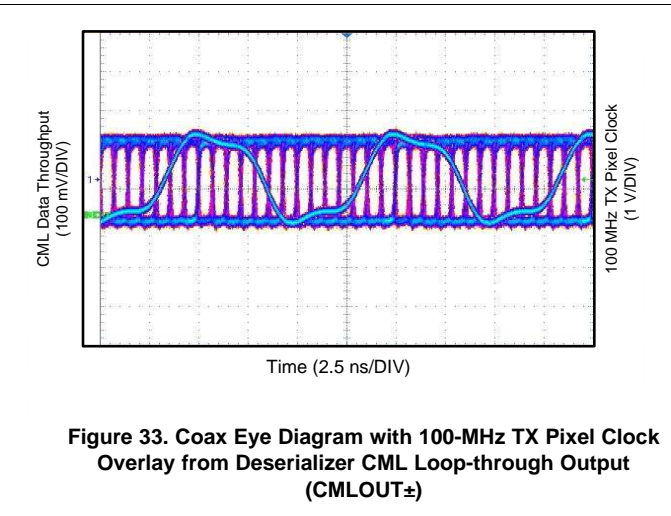
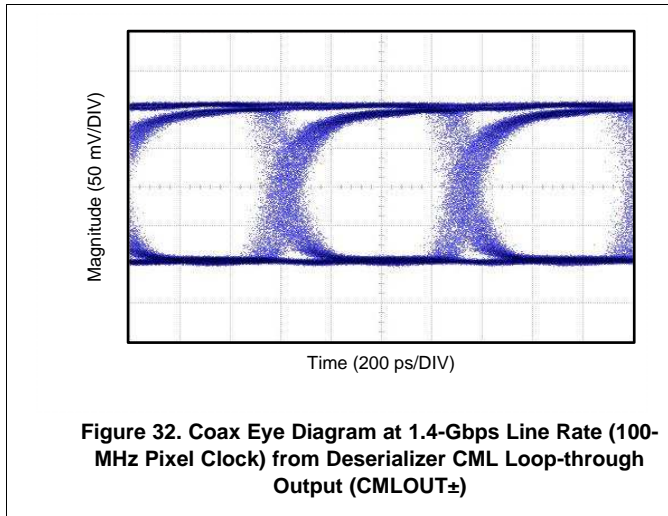
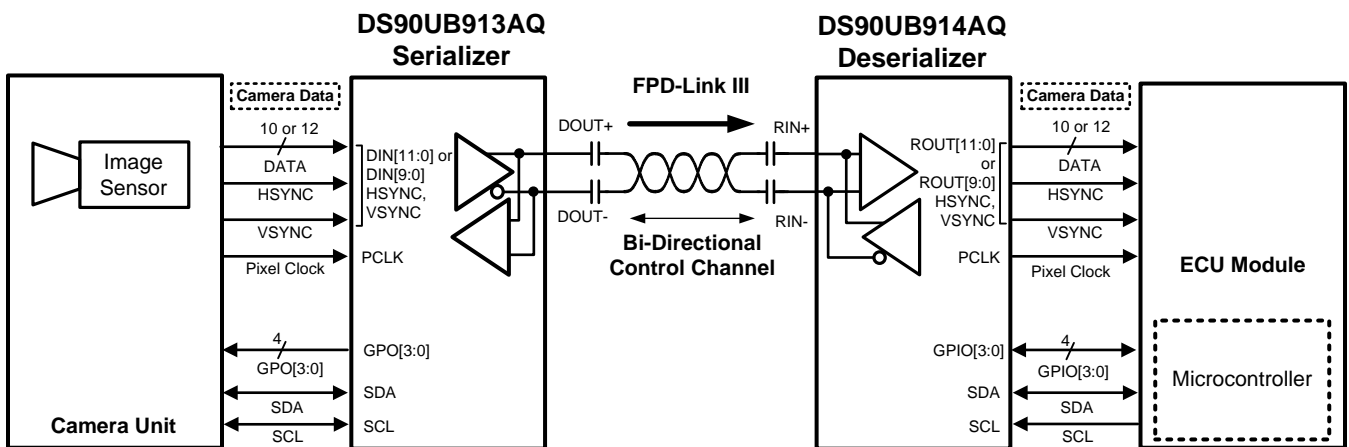

Figure 31. DS90UB913A-Q1 Typical Connection Diagram — Pin Control (Coax)

9.2.1.3 Application Curves



9.2.2 STP Application



9.2.2.1 Design Requirements

For the typical STP design applications, use the following as input parameters

Table 9. STP Design Parameters

DESIGN PARAMETER	EXAMPLE VALUE
V_{DDIO}	1.8 V, 2.8 V, or 3.3 V
V_{DD_n}	1.8 V
AC Coupling Capacitors for DOUT±	0.1 μ F
PCLK Frequency	50 MHz (12-bit low frequency), 75 MHz (12-bit high frequency), 100 MHz (10-bit)

9.2.2.2 Detailed Design Procedure

Figure 35 shows a typical connection of a DS90UB913A-Q1 Serializer using an STP interface.

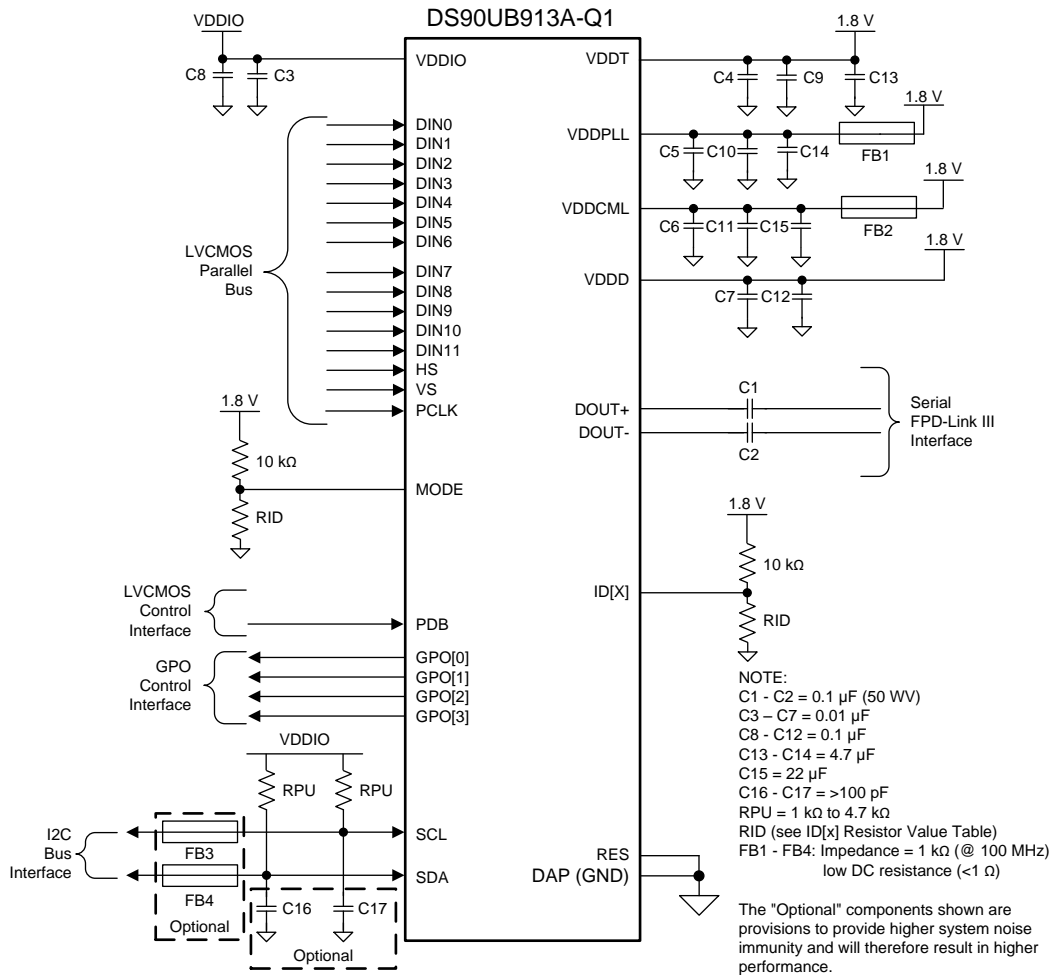

Figure 35. DS90UB913A-Q1 Typical Connection Diagram — Pin Control (STP)

9.2.2.3 Application Curves

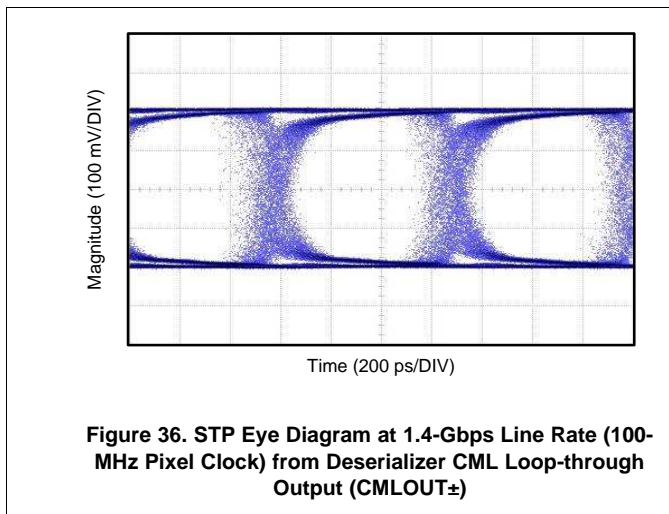

Figure 36. STP Eye Diagram at 1.4-Gbps Line Rate (100-MHz Pixel Clock) from Deserializer CML Loop-through Output (CMLOUT±)

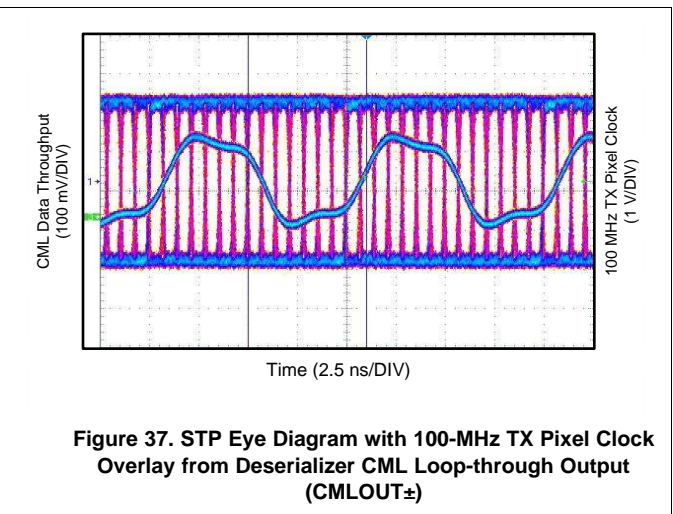

Figure 37. STP Eye Diagram with 100-MHz TX Pixel Clock Overlay from Deserializer CML Loop-through Output (CMLOUT±)

10 Power Supply Recommendations

This device is designed to operate from an input core voltage supply of 1.8 V. Some devices provide separate power and ground terminals for different portions of the circuit. This is done to isolate switching noise effects between different sections of the circuit. Separate planes on the PCB are typically not required. Terminal description tables typically provide guidance on which circuit blocks are connected to which power terminal pairs. In some cases, an external filter may be used to provide clean power to sensitive circuits such as PLLs. The voltage applied on V_{DDIO} (1.8V, 2.8V, 3.3V) or other power supplies making up V_{DD_n} (1.8V) should be at the input pin - any board level DC drop should be compensated (i.e. ferrite beads in the path of the power supply rails).

11 Layout

11.1 Layout Guidelines

Circuit board layout and stack-up for the Ser/Des devices should be designed to provide low-noise power feed to the device. Good layout practice will also separate high frequency or high-level inputs and outputs to minimize unwanted stray noise pickup, feedback and interference. Power system performance may be greatly improved by using thin dielectrics (2 to 4 mils) for power / ground sandwiches. This arrangement provides plane capacitance for the PCB power system with low-inductance parasitics, which has proven especially effective at high frequencies, and makes the value and placement of external bypass capacitors less critical. External bypass capacitors should include both RF ceramic and tantalum electrolytic types. RF capacitors may use values in the range of 0.01 μ F to 0.1 μ F. Tantalum capacitors may be in the 2.2- μ F to 10- μ F range. Voltage rating of the tantalum capacitors should be at least 5X the power supply voltage being used.

Surface mount capacitors are recommended due to their smaller parasitics. When using multiple capacitors per supply pin, locate the smaller value closer to the pin. A large bulk capacitor is recommended at the point of power entry. This is typically in the 50- μ F to 100- μ F range and will smooth low frequency switching noise. It is recommended to connect power and ground pins directly to the power and ground planes with bypass capacitors connected to the plane with via on both ends of the capacitor. Connecting power or ground pins to an external bypass capacitor will increase the inductance of the path.

A small body size X7R chip capacitor, such as 0603, is recommended for external bypass. Its small body size reduces the parasitic inductance of the capacitor. The user must pay attention to the resonance frequency of these external bypass capacitors, usually in the range of 20 to 30 MHz. To provide effective bypassing, multiple capacitors are often used to achieve low impedance between the supply rails over the frequency of interest. At high frequency, it is also a common practice to use two vias from power and ground pins to the planes, reducing the impedance at high frequency.

Some devices provide separate power for different portions of the circuit. This is done to isolate switching noise effects between different sections of the circuit. Separate planes on the PCB are typically not required. Pin Description tables typically provide guidance on which circuit blocks are connected to which power pin pairs. In some cases, an external filter may be used to provide clean power to sensitive circuits such as PLLs.

Use at least a four layer board with a power and ground plane. Locate LVCMOS signals away from the differential lines to prevent coupling from the LVCMOS lines to the differential lines. Closely-coupled differential lines of 100 Ω are typically recommended for differential interconnect. The closely coupled lines help to ensure that coupled noise will appear as common-mode and thus is rejected by the receivers. The tightly coupled lines will also radiate less.

Information on the WQFN style package is provided in TI Application Note: AN-1187/[SNOA401](#).

11.1.1 Interconnect Guidelines

See [SNLA008](#) for full details.

- Use 100 Ω coupled differential pairs
- Use the S/2S/3S rule in spacings
 - – S = space between the pair
 - – 2S = space between pairs
 - – 3S = space to LVCMOS signal
- Minimize the number of Vias
- Use differential connectors when operating above 500 Mbps line speed
- Maintain balance of the traces
- Minimize skew within the pair

Additional general guidance can be found in the LVDS Owner's Manual - available in PDF format from the Texas Instrument web site at: www.ti.com/lvds.

11.2 Layout Example

Stencil parameters such as aperture area ratio and the fabrication process have a significant impact on paste deposition. Inspection of the stencil prior to placement of the WQFN package is highly recommended to improve board assembly yields. If the via and aperture for openings are not carefully monitored, the solder may flow unevenly through the DAP. Stencil parameters for aperture opening and via locations are shown below:

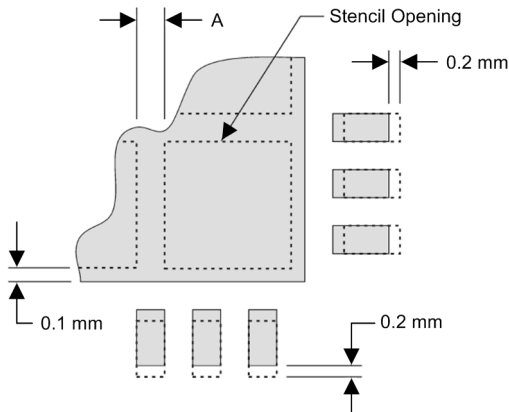

Figure 38. No Pullback WQFN, Single Row Reference Diagram

Table 10. No Pullback WQFN Stencil Aperture Summary for DS90UB913A-Q1

DEVICE	PIN COUNT	MKT DWG	PCB I/O PAD SIZE (mm)	PCB PITCH (mm)	PCB DAP SIZE(mm)	STENCIL I/O APERTURE (mm)	STENCIL DAP APERTURE (mm)	NUMBER OF DAP APERTURE OPENINGS	GAP BETWEEN DAP APERTURE (Dim A mm)
DS90UB913A-Q1	32	RTV	0.25 x 0.6	0.5	3.1 x 3.1	0.25 x 0.7	1.4 x 1.4	4	0.2

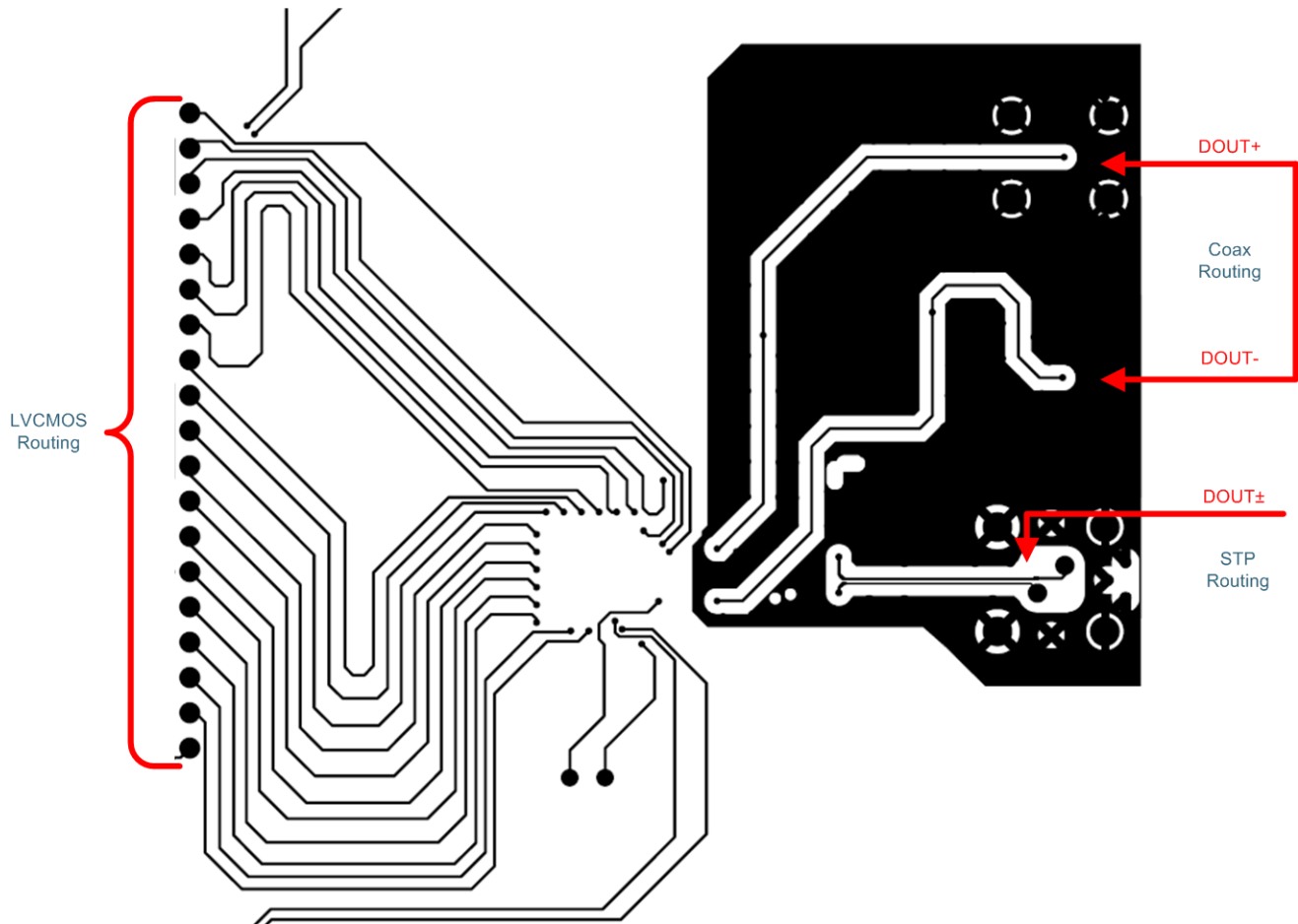

Figure 39. DS90UB913A-Q1 Serializer Example Layout

The following PCB layout examples are derived from the layout design of the DS90UB913A-Q1 Evaluation Module (SNLU135). These graphics and additional layout description are used to demonstrate both proper routing and proper solder techniques when designing in this Serializer.

12 Device and Documentation Support

12.1 Documentation Support

12.1.1 Related Documentation

For related documentation see the following:

- *DS90UB913A-CXEVM & DS90UB914A-CXEVM REV A User's Guide*, [SNLU135](#)
- *I2C over DS90UB913/4 FPD-Link III with Bidirectional Control Channel*, [SNLA222](#)
- *Sending Power Over Coax in DS90UB913A Designs*, [SNLA224](#)
- *Soldering Specifications Application Report*, [SNOA549](#)
- *IC Package Thermal Metrics Application Report*, [SPRA953](#)
- *Leadless Leadframe Package (LLP) Application Report*, [SNOA401](#)
- *LVDS Owner's Manual*, [SNLA187](#)
- *Cable Requirements for the DS90UB913A & DS90UB914A*, [SNLA229](#)

12.2 Community Resources

The following links connect to TI community resources. Linked contents are provided "AS IS" by the respective contributors. They do not constitute TI specifications and do not necessarily reflect TI's views; see TI's [Terms of Use](#).

TI E2E™ Online Community *TI's Engineer-to-Engineer (E2E) Community*. Created to foster collaboration among engineers. At e2e.ti.com, you can ask questions, share knowledge, explore ideas and help solve problems with fellow engineers.

Design Support *TI's Design Support* Quickly find helpful E2E forums along with design support tools and contact information for technical support.

12.3 Trademarks

E2E is a trademark of Texas Instruments.
 All other trademarks are the property of their respective owners.

12.4 Electrostatic Discharge Caution



These devices have limited built-in ESD protection. The leads should be shorted together or the device placed in conductive foam during storage or handling to prevent electrostatic damage to the MOS gates.

12.5 Glossary

[SLYZ022](#) — *TI Glossary*.

This glossary lists and explains terms, acronyms, and definitions.

13 Mechanical, Packaging, and Orderable Information

The following pages include mechanical, packaging, and orderable information. This information is the most current data available for the designated devices. This data is subject to change without notice and revision of this document. For browser-based versions of this data sheet, refer to the left-hand navigation.

PACKAGING INFORMATION

Orderable Device	Status (1)	Package Type	Package Drawing	Pins	Package Qty	Eco Plan (2)	Lead/Ball Finish (6)	MSL Peak Temp (3)	Op Temp (°C)	Device Marking (4/5)	Samples
DS90UB913ATRTRVJQ1	ACTIVE	WQFN	RTV	32	2500	Green (RoHS & no Sb/Br)	CU SN	Level-3-260C-168 HR	-40 to 105	UB913AQ	Samples
DS90UB913ATRTRVRQ1	ACTIVE	WQFN	RTV	32	1000	Green (RoHS & no Sb/Br)	CU SN	Level-3-260C-168 HR	-40 to 105	UB913AQ	Samples
DS90UB913ATRTRVTQ1	ACTIVE	WQFN	RTV	32	250	Green (RoHS & no Sb/Br)	CU SN	Level-3-260C-168 HR	-40 to 105	UB913AQ	Samples

(1) The marketing status values are defined as follows:

ACTIVE: Product device recommended for new designs.

LIFEBUY: TI has announced that the device will be discontinued, and a lifetime-buy period is in effect.

NRND: Not recommended for new designs. Device is in production to support existing customers, but TI does not recommend using this part in a new design.

PREVIEW: Device has been announced but is not in production. Samples may or may not be available.

OBsolete: TI has discontinued the production of the device.

(2) Eco Plan - The planned eco-friendly classification: Pb-Free (RoHS), Pb-Free (RoHS Exempt), or Green (RoHS & no Sb/Br) - please check <http://www.ti.com/productcontent> for the latest availability information and additional product content details.

TBD: The Pb-Free/Green conversion plan has not been defined.

Pb-Free (RoHS): TI's terms "Lead-Free" or "Pb-Free" mean semiconductor products that are compatible with the current RoHS requirements for all 6 substances, including the requirement that lead not exceed 0.1% by weight in homogeneous materials. Where designed to be soldered at high temperatures, TI Pb-Free products are suitable for use in specified lead-free processes.

Pb-Free (RoHS Exempt): This component has a RoHS exemption for either 1) lead-based flip-chip solder bumps used between the die and package, or 2) lead-based die adhesive used between the die and leadframe. The component is otherwise considered Pb-Free (RoHS compatible) as defined above.

Green (RoHS & no Sb/Br): TI defines "Green" to mean Pb-Free (RoHS compatible), and free of Bromine (Br) and Antimony (Sb) based flame retardants (Br or Sb do not exceed 0.1% by weight in homogeneous material)

(3) MSL, Peak Temp. - The Moisture Sensitivity Level rating according to the JEDEC industry standard classifications, and peak solder temperature.

(4) There may be additional marking, which relates to the logo, the lot trace code information, or the environmental category on the device.

(5) Multiple Device Markings will be inside parentheses. Only one Device Marking contained in parentheses and separated by a "~" will appear on a device. If a line is indented then it is a continuation of the previous line and the two combined represent the entire Device Marking for that device.

(6) Lead/Ball Finish - Orderable Devices may have multiple material finish options. Finish options are separated by a vertical ruled line. Lead/Ball Finish values may wrap to two lines if the finish value exceeds the maximum column width.

Important Information and Disclaimer: The information provided on this page represents TI's knowledge and belief as of the date that it is provided. TI bases its knowledge and belief on information provided by third parties, and makes no representation or warranty as to the accuracy of such information. Efforts are underway to better integrate information from third parties. TI has taken and

continues to take reasonable steps to provide representative and accurate information but may not have conducted destructive testing or chemical analysis on incoming materials and chemicals. TI and TI suppliers consider certain information to be proprietary, and thus CAS numbers and other limited information may not be available for release.

In no event shall TI's liability arising out of such information exceed the total purchase price of the TI part(s) at issue in this document sold by TI to Customer on an annual basis.

TAPE AND REEL INFORMATION



QUADRANT ASSIGNMENTS FOR PIN 1 ORIENTATION IN TAPE



*All dimensions are nominal

Device	Package Type	Package Drawing	Pins	SPQ	Reel Diameter (mm)	Reel Width W1 (mm)	A0 (mm)	B0 (mm)	K0 (mm)	P1 (mm)	W (mm)	Pin1 Quadrant
DS90UB913ATRJVJQ1	WQFN	RTV	32	2500	330.0	12.4	5.3	5.3	1.3	8.0	12.0	Q1
DS90UB913ATRVRQ1	WQFN	RTV	32	1000	178.0	12.4	5.3	5.3	1.3	8.0	12.0	Q1
DS90UB913ATRVTQ1	WQFN	RTV	32	250	178.0	12.4	5.3	5.3	1.3	8.0	12.0	Q1

TAPE AND REEL BOX DIMENSIONS

*All dimensions are nominal

Device	Package Type	Package Drawing	Pins	SPQ	Length (mm)	Width (mm)	Height (mm)
DS90UB913ATRJVJQ1	WQFN	RTV	32	2500	367.0	367.0	35.0
DS90UB913ATRVRQ1	WQFN	RTV	32	1000	213.0	191.0	55.0
DS90UB913ATRVTQ1	WQFN	RTV	32	250	213.0	191.0	55.0

RTV0032A

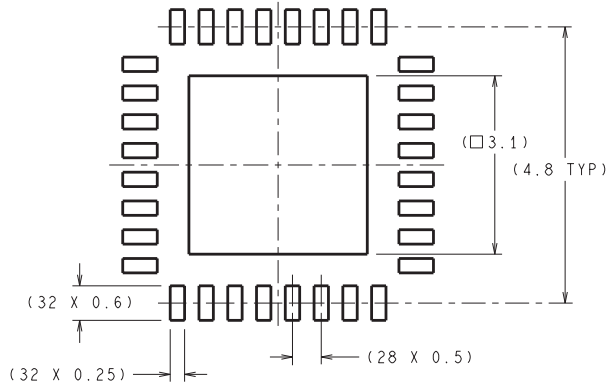

DIMENSIONS ARE IN MILLIMETERS
DIMENSIONS IN () FOR REFERENCE ONLY



RECOMMENDED LAND PATTERN

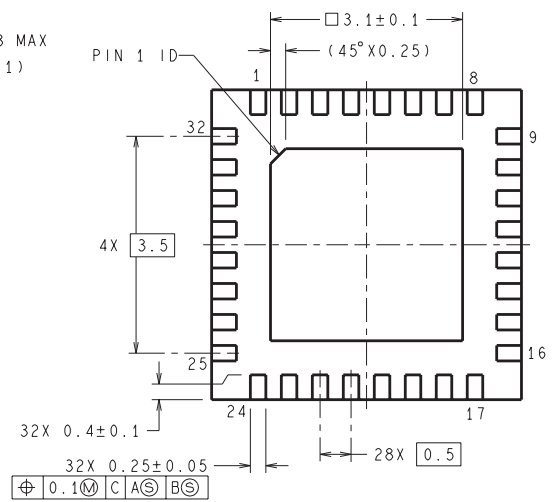
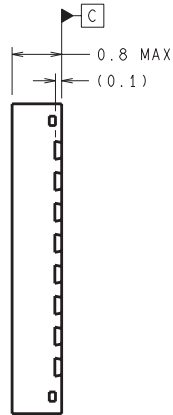
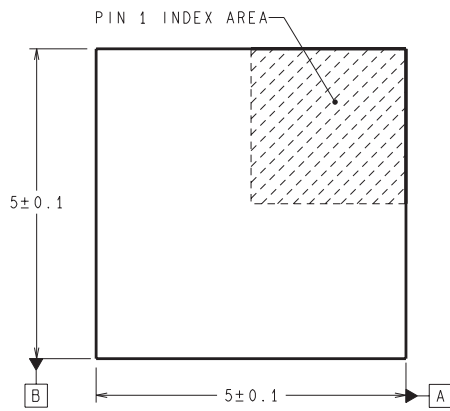

SQA32A (Rev B)

IMPORTANT NOTICE

Texas Instruments Incorporated and its subsidiaries (TI) reserve the right to make corrections, enhancements, improvements and other changes to its semiconductor products and services per JESD46, latest issue, and to discontinue any product or service per JESD48, latest issue. Buyers should obtain the latest relevant information before placing orders and should verify that such information is current and complete. All semiconductor products (also referred to herein as "components") are sold subject to TI's terms and conditions of sale supplied at the time of order acknowledgment.

TI warrants performance of its components to the specifications applicable at the time of sale, in accordance with the warranty in TI's terms and conditions of sale of semiconductor products. Testing and other quality control techniques are used to the extent TI deems necessary to support this warranty. Except where mandated by applicable law, testing of all parameters of each component is not necessarily performed.

TI assumes no liability for applications assistance or the design of Buyers' products. Buyers are responsible for their products and applications using TI components. To minimize the risks associated with Buyers' products and applications, Buyers should provide adequate design and operating safeguards.

TI does not warrant or represent that any license, either express or implied, is granted under any patent right, copyright, mask work right, or other intellectual property right relating to any combination, machine, or process in which TI components or services are used. Information published by TI regarding third-party products or services does not constitute a license to use such products or services or a warranty or endorsement thereof. Use of such information may require a license from a third party under the patents or other intellectual property of the third party, or a license from TI under the patents or other intellectual property of TI.

Reproduction of significant portions of TI information in TI data books or data sheets is permissible only if reproduction is without alteration and is accompanied by all associated warranties, conditions, limitations, and notices. TI is not responsible or liable for such altered documentation. Information of third parties may be subject to additional restrictions.

Resale of TI components or services with statements different from or beyond the parameters stated by TI for that component or service voids all express and any implied warranties for the associated TI component or service and is an unfair and deceptive business practice. TI is not responsible or liable for any such statements.

Buyer acknowledges and agrees that it is solely responsible for compliance with all legal, regulatory and safety-related requirements concerning its products, and any use of TI components in its applications, notwithstanding any applications-related information or support that may be provided by TI. Buyer represents and agrees that it has all the necessary expertise to create and implement safeguards which anticipate dangerous consequences of failures, monitor failures and their consequences, lessen the likelihood of failures that might cause harm and take appropriate remedial actions. Buyer will fully indemnify TI and its representatives against any damages arising out of the use of any TI components in safety-critical applications.

In some cases, TI components may be promoted specifically to facilitate safety-related applications. With such components, TI's goal is to help enable customers to design and create their own end-product solutions that meet applicable functional safety standards and requirements. Nonetheless, such components are subject to these terms.

No TI components are authorized for use in FDA Class III (or similar life-critical medical equipment) unless authorized officers of the parties have executed a special agreement specifically governing such use.

Only those TI components which TI has specifically designated as military grade or "enhanced plastic" are designed and intended for use in military/aerospace applications or environments. Buyer acknowledges and agrees that any military or aerospace use of TI components which have **not** been so designated is solely at the Buyer's risk, and that Buyer is solely responsible for compliance with all legal and regulatory requirements in connection with such use.

TI has specifically designated certain components as meeting ISO/TS16949 requirements, mainly for automotive use. In any case of use of non-designated products, TI will not be responsible for any failure to meet ISO/TS16949.

Products

Audio	www.ti.com/audio
Amplifiers	amplifier.ti.com
Data Converters	dataconverter.ti.com
DLP® Products	www.dlp.com
DSP	dsp.ti.com
Clocks and Timers	www.ti.com/clocks
Interface	interface.ti.com
Logic	logic.ti.com
Power Mgmt	power.ti.com
Microcontrollers	microcontroller.ti.com
RFID	www.ti-rfid.com
OMAP Applications Processors	www.ti.com/omap
Wireless Connectivity	www.ti.com/wirelessconnectivity

Applications

Automotive and Transportation	www.ti.com/automotive
Communications and Telecom	www.ti.com/communications
Computers and Peripherals	www.ti.com/computers
Consumer Electronics	www.ti.com/consumer-apps
Energy and Lighting	www.ti.com/energy
Industrial	www.ti.com/industrial
Medical	www.ti.com/medical
Security	www.ti.com/security
Space, Avionics and Defense	www.ti.com/space-avionics-defense
Video and Imaging	www.ti.com/video

TI E2E Community

e2e.ti.com