

DS34C87T CMOS Quad TRI-STATE Differential Line Driver

 Check for Samples: [DS34C87T](#)

FEATURES

- TTL Input Compatible
- Typical Propagation Delays: 6 ns
- Typical Output Skew: 0.5 ns
- Outputs Won't Load Line When $V_{CC} = 0V$
- Meets the Requirements of EIA Standard RS-422
- Operation from Single 5V Supply
- TRI-STATE Outputs for Connection to System Buses
- Low Quiescent Current
- Available in Surface Mount

DESCRIPTION

The DS34C87T is a quad differential line driver designed for digital data transmission over balanced lines. The DS34C87T meets all the requirements of EIA standard RS-422 while retaining the low power characteristics of CMOS. This enables the construction of serial and terminal interfaces while maintaining minimal power consumption.

The DS34C87T accepts TTL or CMOS input levels and translates these to RS-422 output levels. This part uses special output circuitry that enables the individual drivers to power down without loading down the bus. This device has separate enable circuitry for each pair of the four drivers. The DS34C87T is pin compatible to the DS3487T.

All inputs are protected against damage due to electrostatic discharge by diodes to V_{CC} and ground.

Connection and Logic Diagrams

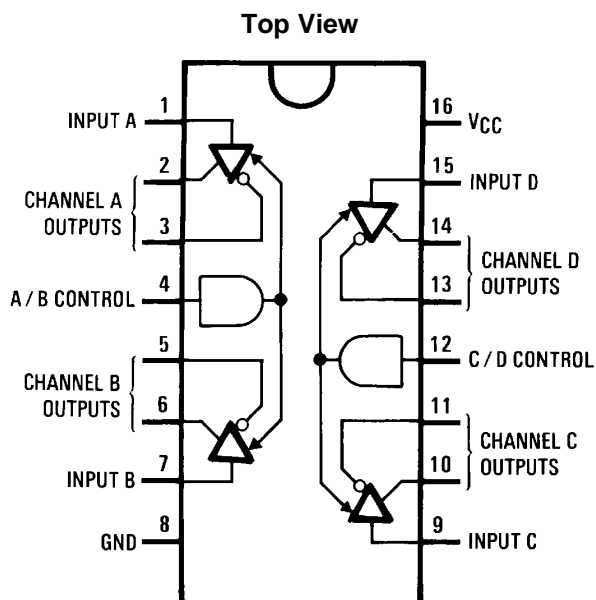

See [PIN DESCRIPTIONS](#) for details.

Figure 1. PDIP Package
See Package Numbers D0016A or NFG0016E

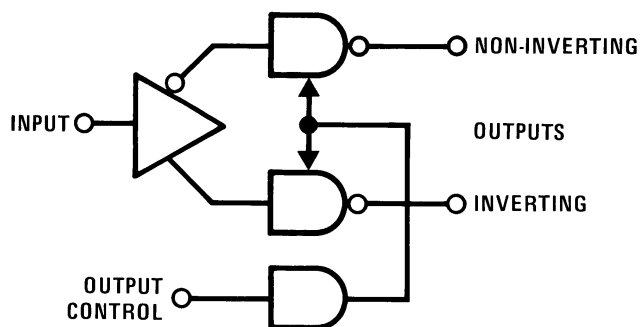

Figure 2. Logic Diagram



Please be aware that an important notice concerning availability, standard warranty, and use in critical applications of Texas Instruments semiconductor products and disclaimers thereto appears at the end of this data sheet.

All trademarks are the property of their respective owners.

Truth Table⁽¹⁾

Input	Control	Non-Inverting	Inverting
	Input	Output	Output
H	H	H	L
L	H	L	H
X	L	Z	Z

- (1) L = Low logic state
H = High logic state
X = Irrelevant
Z = TRI-STATE (high performance)



These devices have limited built-in ESD protection. The leads should be shorted together or the device placed in conductive foam during storage or handling to prevent electrostatic damage to the MOS gates.

Absolute Maximum Ratings⁽¹⁾⁽²⁾⁽³⁾⁽⁴⁾

Supply Voltage (V_{CC})	-0.5 to 7.0V
DC Voltage (V_{IN})	-1.5 to $V_{CC} + 1.5V$
DC Output Voltage (V_{OUT})	-0.5 to 7V
Clamp Diode Current (I_{IK}, I_{OK})	± 20 mA
DC Output Current, per pin (I_{OUT})	± 150 mA
DC V_{CC} or GND Current (I_{CC})	± 150 mA
Storage Temperature Range (T_{STG})	-65°C to +150°C
Maximum Power Dissipation (P_D) @ 25°C ⁽⁵⁾	
PDIP Package	1736 mW
SOIC Package	1226 mW
Lead Temperature (T_L)	
(Soldering 4 sec)	260°C
This device does not meet 2000V ESD rating.⁽⁶⁾	

- (1) Unless otherwise specified, all voltages are referenced to ground. All currents into device pins are positive; all currents out of device pins are negative.
- (2) Absolute Maximum Ratings are those values beyond which the safety of the device cannot be specified. They are not meant to imply that the device should be operated at these limits. The table of "Electrical Characteristics" provide conditions for actual device operation.
- (3) ESD Rating: HBM (1.5 k Ω , 100 pF) Inputs $\geq 1500V$ Outputs $\geq 1000V$ EIAJ (0 Ω , 200 pF) All Pins $\geq 350V$
- (4) If Military/Aerospace specified devices are required, please contact the Texas Instruments Sales Office/ Distributors for availability and specifications.
- (5) Ratings apply to ambient temperature at 25°C. Above this temperature derate NFG0016E Package 13.89 mW/°C, and D0016A Package 9.80 mW/°C.
- (6) ESD Rating: HBM (1.5 k Ω , 100 pF) Inputs $\geq 1500V$ Outputs $\geq 1000V$ EIAJ (0 Ω , 200 pF) All Pins $\geq 350V$

Operating Conditions

	Min	Max	Units
Supply Voltage (V_{CC})	4.50	5.50	V
DC Input or Output Voltage (V_{IN}, V_{OUT})	0	V_{CC}	V
Operating Temperature Range (T_A) DS34C87T	-40	+85	°C
Input Rise or Fall Times (t_r, t_f)		500	ns

DC Electrical Characteristics⁽¹⁾

 $V_{CC} = 5V \pm 10\%$ (unless otherwise specified)

Parameter		Test Conditions	Min	Typ	Max	Units
V_{IH}	High Level Input Voltage		2.0			V
V_{IL}	Low Level Input Voltage				0.8	V
V_{OH}	High Level Output Voltage	$V_{IN} = V_{IH}$ or V_{IL} , $I_{OUT} = -20$ mA	2.5	3.4		V
V_{OL}	Low Level Output Voltage	$V_{IN} = V_{IH}$ or V_{IL} , $I_{OUT} = 48$ mA		0.3	0.5	V
V_T	Differential Output Voltage	$R_L = 100 \Omega$ See ⁽²⁾	2.0	3.1		V
$ V_T - \bar{V}_T $	Difference In Differential Output	$R_L = 100 \Omega$ See ⁽²⁾			0.4	V
V_{OS}	Common Mode Output Voltage	$R_L = 100 \Omega$ See ⁽²⁾		2.0	3.0	V
$ V_{OS} - \bar{V}_{OS} $	Difference In Common Mode Output	$R_L = 100 \Omega$ See ⁽²⁾			0.4	V
I_{IN}	Input Current	$V_{IN} = V_{CC}, GND, V_{IH},$ or V_{IL}			± 1.0	μA
I_{CC}	Quiescent Supply Current	$I_{OUT} = 0 \mu A$, $V_{IN} = V_{CC}$ or GND $V_{IN} = 2.4V$ or $0.5V$ ⁽³⁾		200 0.8	500 2.0	μA mA
I_{OZ}	TRI-STATE Output Leakage Current	$V_{OUT} = V_{CC}$ or GND Control = V_{IL}		± 0.5	± 5.0	μA
I_{SC}	Output Short Circuit Current	$V_{IN} = V_{CC}$ or GND See ⁽²⁾ and ⁽⁴⁾	-30		-150	mA
I_{OFF}	Power Off Output Leakage Current	$V_{CC} = 0V$ See ⁽²⁾ $V_{OUT} = 6V$ $V_{OUT} = -0.25V$			100 -100	μA μA

(1) Unless otherwise specified, min/max limits apply across the $-40^\circ C$ to $85^\circ C$ temperature range. All typicals are given for $V_{CC} = 5V$ and $T_A = 25^\circ C$.

(2) See EIA Specification RS-422 for exact test conditions.

(3) Measured per input. All other inputs at V_{CC} or GND.

(4) This is the current sourced when a high output is shorted to ground. Only one output at a time should be shorted.

Switching Characteristics⁽¹⁾

$V_{CC} = 5V \pm 10\%$, $t_r, t_f \leq 6$ ns (Figure 3, Figure 4, Figure 5, Figure 6)

Parameter		Test Conditions	Min	Typ	Max	Units
t_{PLH}, t_{PHL}	Propagation Delay Input to Output	S1 Open		6	11	ns
Skew	See ⁽²⁾	S1 Open		0.5	3	ns
t_{TLH}, t_{THL}	Differential Output Rise And Fall Times	S1 Open		6	10	ns
t_{PZH}	Output Enable Time	S1 Closed		12	25	ns
t_{PZL}	Output Enable Time	S1 Closed		13	26	ns
t_{PHZ}	Output Disable Time ⁽³⁾	S1 Closed		4	8	ns
t_{PLZ}	Output Disable Time ⁽³⁾	S1 Closed		6	12	ns
C_{PD}	Power Dissipation Capacitance ⁽⁴⁾			100		pF
C_{IN}	Input Capacitance			6		pF

- (1) Unless otherwise specified, min/max limits apply across the -40°C to 85°C temperature range. All typicals are given for $V_{CC} = 5V$ and $T_A = 25^{\circ}\text{C}$.
- (2) Skew is defined as the difference in propagation delays between complementary outputs at the 50% point.
- (3) Output disable time is the delay from the control input being switched to the output transistors turning off. The actual disable times are less than indicated due to the delay added by the RC time constant of the load.
- (4) C_{PD} determines the no load dynamic power consumption, $P_D = C_{PD} V_{CC}^2 f + I_{CC} V_{CC}$, and the no load dynamic current consumption, $I_S = C_{PD} V_{CC} f + I_{CC}$.

Comparison Table of Switching Characteristics into “LS-Type” Load⁽¹⁾

$V_{CC} = 5V$, $T_A = +25^{\circ}\text{C}$, $t_r \leq 6$ ns, $t_f \leq 6$ ns (Figure 6, Figure 7, Figure 8, Figure 9, Figure 10, Figure 11)

Parameter		Test Conditions	DS34C87		DS3487		Units
			Typ	Max	Typ	Max	
t_{PLH}, t_{PHL}	Propagation Delay Input to Output		6	10	10	15	ns
Skew	See ⁽²⁾		1.5	2.0			ns
t_{THL}, t_{TLH}	Differential Output Rise and Fall Times		4	7	10	15	ns
t_{PHZ}	Output Disable Time See ⁽³⁾	$C_L = 50$ pF, $R_L = 200\Omega$, S1 Closed, S2 Closed	8	11	17	25	ns
t_{PLZ}	Output Disable Time See ⁽³⁾	$C_L = 50$ pF, $R_L = 200\Omega$, S1 Closed, S2 Closed	7	10	15	25	ns
t_{PZH}	Output Enable Time	$C_L = 50$ pF, $R_L = \infty$, S1 Open, S2 Closed	11	19	11	25	ns
t_{PZL}	Output Enable Time	$C_L = 50$ pF, $R_L = 200\Omega$, S1 Closed, S2 Open	14	21	15	25	ns

- (1) This table is provided for comparison purposes only. The values in this table for the DS34C87 reflect the performance of the device but are not tested or ensured.
- (2) Skew is defined as the difference in propagation delays between complementary outputs at the 50% point.
- (3) Output disable time is the delay from the control input being switched to the output transistors turning off. The actual disable times are less than indicated due to the delay added by the RC time constant of the load.

AC TEST CIRCUIT AND SWITCHING TIME WAVEFORMS

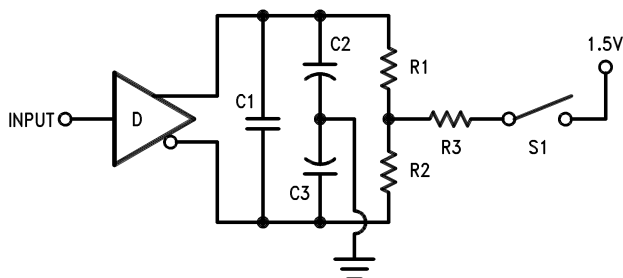

Note: C1 = C2 = C3 = 40 pF (including Probe and Jig Capacitance), R1 = R2 = 50Ω, R3 = 500Ω

Figure 3. AC Test Circuit

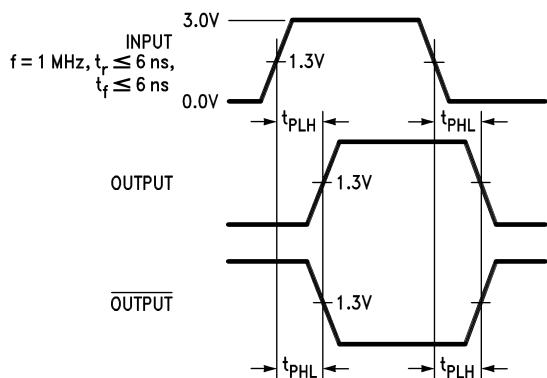

Figure 4. Propagation Delays

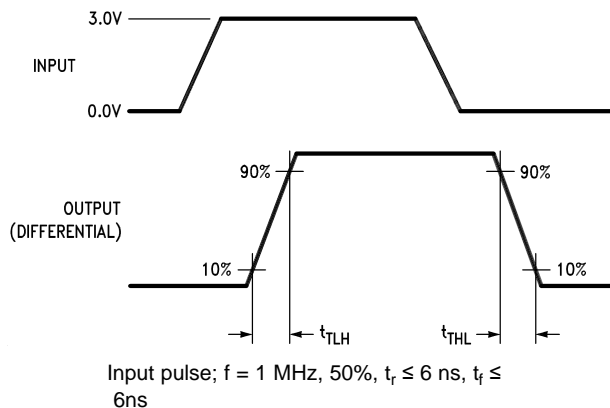

Figure 6. Differential Rise and Fall Times

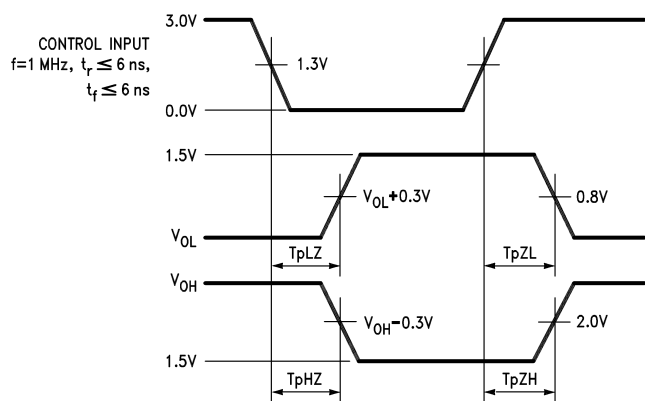

Figure 5. Enable and Disable Times

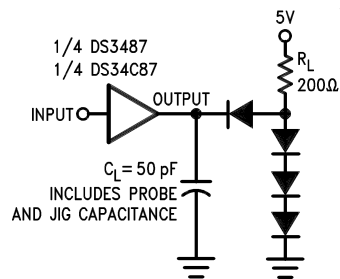

Figure 7. Propagation Delays Test Circuit for "LS-Type" Load

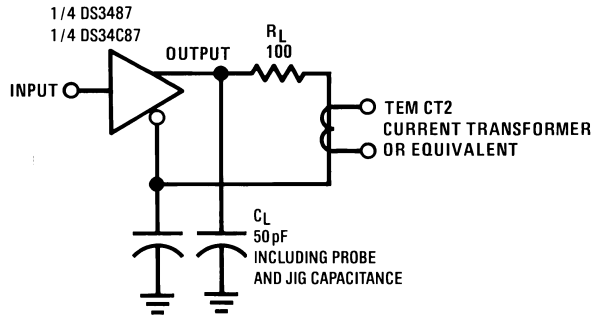

Figure 8. Differential Rise and Fall Times Test Circuit for “LS-Type” Load

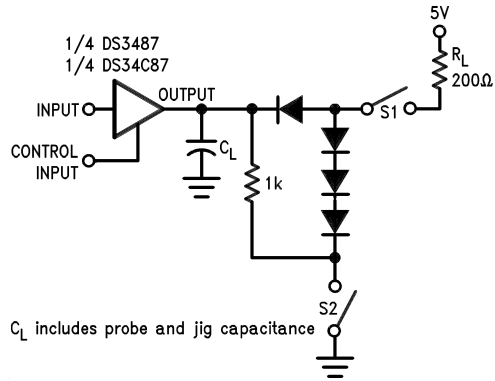

Figure 9. Load Enable and Disable Times Test Circuit for “LS-Type” Load

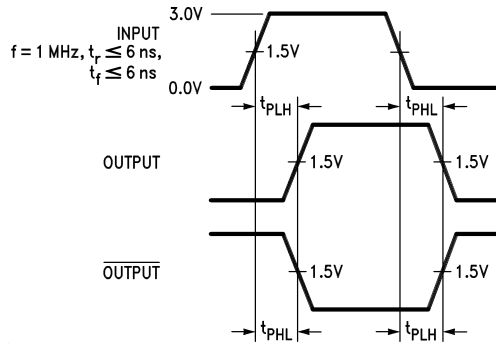

Figure 10. Load Propagation Delays for “LS-Type” Load

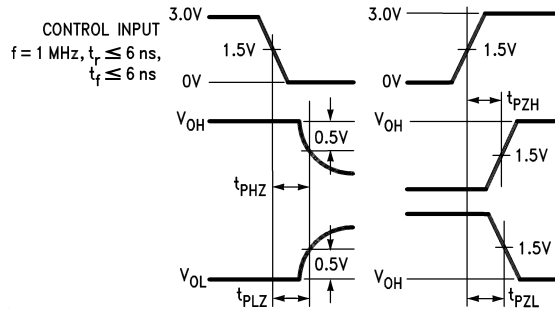
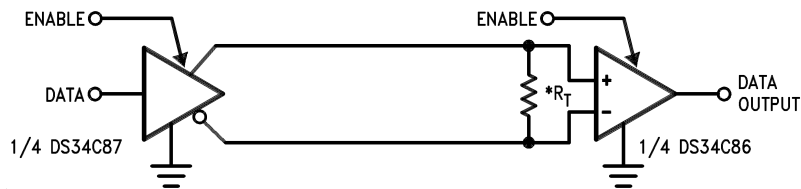

Figure 11. Load Enable and Disable Times for “LS-Type” Load

TYPICAL APPLICATIONS



*RT is optional although highly recommended to reduce reflection.

PIN DESCRIPTIONS

Pin Number (PDIP or SOIC package)	Pin Name	Function
1	INPUT A	Channel A - TTL/CMOS input
2	OUTPUT A - True	True Output for Channel A, RS422 Levels
3	OUTPUT A - Inverting	Inverting Output for Channel A, RS422 Levels
4	A/B CONTROL	Enable Pin for Channels A and B, Active High, TTL/CMOS Levels
5	OUTPUT B - Inverting	Inverting Output for Channel B, RS422 Levels
6	OUTPUT B - True	True Output for Channel B, RS422 Levels
7	INPUT B	Channel B - TTL/CMOS input
8	GND	Ground Pin (0 V)
9	INPUT C	Channel C - TTL/CMOS input
10	OUTPUT C - True	True Output for Channel C, RS422 Levels
11	OUTPUT C - Inverting	Inverting Output for Channel C, RS422 Levels
12	C/D CONTROL	Enable Pin for Channels C and D, Active High, TTL/CMOS Levels
13	OUTPUT D - Inverting	Inverting Output for Channel D, RS422 Levels
14	OUTPUT D - True	True Output for Channel D, RS422 Levels
15	INPUT D	Channel D - TTL/CMOS input
16	V _{CC}	Power Supply Pin, 5.0V typical

REVISION HISTORY

Changes from Revision A (April 2013) to Revision B	Page
• Changed layout of National Data Sheet to TI format	7

PACKAGING INFORMATION

Orderable Device	Status (1)	Package Type	Package Drawing	Pins	Package Qty	Eco Plan (2)	Lead/Ball Finish	MSL Peak Temp (3)	Op Temp (°C)	Top-Side Markings (4)	Samples
DS34C87TM	ACTIVE	SOIC	D	16	48	TBD	Call TI	Call TI	-40 to 85	DS34C87TM	Samples
DS34C87TM/NOPB	ACTIVE	SOIC	D	16	48	Green (RoHS & no Sb/Br)	CU SN	Level-1-260C-UNLIM	-40 to 85	DS34C87TM	Samples
DS34C87TMX	ACTIVE	SOIC	D	16	2500	TBD	Call TI	Call TI	-40 to 85	DS34C87TM	Samples
DS34C87TMX/NOPB	ACTIVE	SOIC	D	16	2500	Green (RoHS & no Sb/Br)	CU SN	Level-1-260C-UNLIM	-40 to 85	DS34C87TM	Samples

(1) The marketing status values are defined as follows:

ACTIVE: Product device recommended for new designs.

LIFEBUY: TI has announced that the device will be discontinued, and a lifetime-buy period is in effect.

NRND: Not recommended for new designs. Device is in production to support existing customers, but TI does not recommend using this part in a new design.

PREVIEW: Device has been announced but is not in production. Samples may or may not be available.

OBSOLETE: TI has discontinued the production of the device.

(2) Eco Plan - The planned eco-friendly classification: Pb-Free (RoHS), Pb-Free (RoHS Exempt), or Green (RoHS & no Sb/Br) - please check <http://www.ti.com/productcontent> for the latest availability information and additional product content details.

TBD: The Pb-Free/Green conversion plan has not been defined.

Pb-Free (RoHS): TI's terms "Lead-Free" or "Pb-Free" mean semiconductor products that are compatible with the current RoHS requirements for all 6 substances, including the requirement that lead not exceed 0.1% by weight in homogeneous materials. Where designed to be soldered at high temperatures, TI Pb-Free products are suitable for use in specified lead-free processes.

Pb-Free (RoHS Exempt): This component has a RoHS exemption for either 1) lead-based flip-chip solder bumps used between the die and package, or 2) lead-based die adhesive used between the die and leadframe. The component is otherwise considered Pb-Free (RoHS compatible) as defined above.

Green (RoHS & no Sb/Br): TI defines "Green" to mean Pb-Free (RoHS compatible), and free of Bromine (Br) and Antimony (Sb) based flame retardants (Br or Sb do not exceed 0.1% by weight in homogeneous material)

(3) MSL, Peak Temp. -- The Moisture Sensitivity Level rating according to the JEDEC industry standard classifications, and peak solder temperature.

(4) Multiple Top-Side Markings will be inside parentheses. Only one Top-Side Marking contained in parentheses and separated by a "~" will appear on a device. If a line is indented then it is a continuation of the previous line and the two combined represent the entire Top-Side Marking for that device.

Important Information and Disclaimer: The information provided on this page represents TI's knowledge and belief as of the date that it is provided. TI bases its knowledge and belief on information provided by third parties, and makes no representation or warranty as to the accuracy of such information. Efforts are underway to better integrate information from third parties. TI has taken and continues to take reasonable steps to provide representative and accurate information but may not have conducted destructive testing or chemical analysis on incoming materials and chemicals. TI and TI suppliers consider certain information to be proprietary, and thus CAS numbers and other limited information may not be available for release.

In no event shall TI's liability arising out of such information exceed the total purchase price of the TI part(s) at issue in this document sold by TI to Customer on an annual basis.

TAPE AND REEL INFORMATION

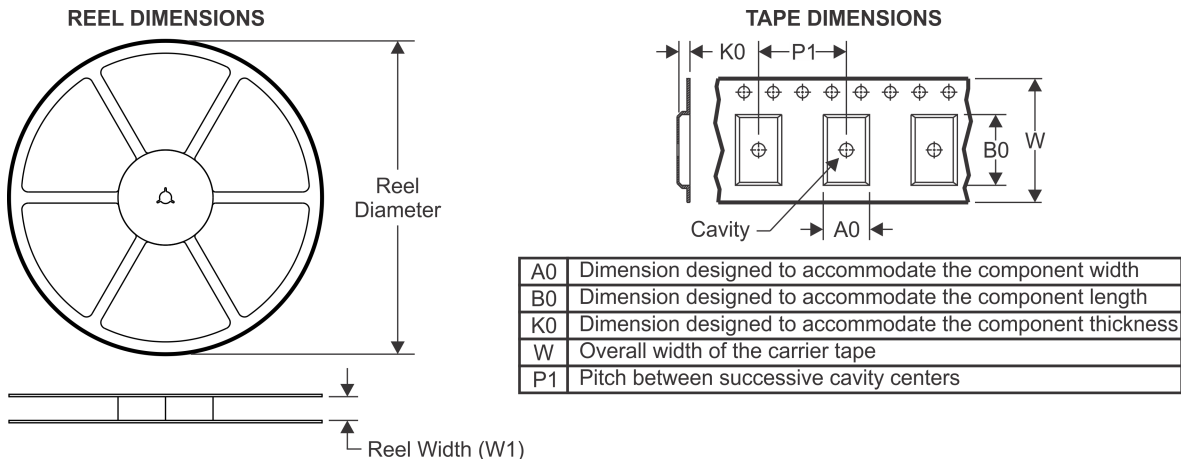

QUADRANT ASSIGNMENTS FOR PIN 1 ORIENTATION IN TAPE



*All dimensions are nominal

Device	Package Type	Package Drawing	Pins	SPQ	Reel Diameter (mm)	Reel Width W1 (mm)	A0 (mm)	B0 (mm)	K0 (mm)	P1 (mm)	W (mm)	Pin1 Quadrant
DS34C87TMX	SOIC	D	16	2500	330.0	16.4	6.5	10.3	2.3	8.0	16.0	Q1
DS34C87TMX/NOPB	SOIC	D	16	2500	330.0	16.4	6.5	10.3	2.3	8.0	16.0	Q1

TAPE AND REEL BOX DIMENSIONS



*All dimensions are nominal

Device	Package Type	Package Drawing	Pins	SPQ	Length (mm)	Width (mm)	Height (mm)
DS34C87TMX	SOIC	D	16	2500	367.0	367.0	35.0
DS34C87TMX/NOPB	SOIC	D	16	2500	367.0	367.0	35.0

D (R-PDSO-G16)

PLASTIC SMALL OUTLINE



- NOTES:
- A. All linear dimensions are in inches (millimeters).
 - B. This drawing is subject to change without notice.
 - C. Body length does not include mold flash, protrusions, or gate burrs. Mold flash, protrusions, or gate burrs shall not exceed 0.006 (0,15) each side.
 - D. Body width does not include interlead flash. Interlead flash shall not exceed 0.017 (0,43) each side.
 - E. Reference JEDEC MS-012 variation AC.

IMPORTANT NOTICE

Texas Instruments Incorporated and its subsidiaries (TI) reserve the right to make corrections, enhancements, improvements and other changes to its semiconductor products and services per JESD46, latest issue, and to discontinue any product or service per JESD48, latest issue. Buyers should obtain the latest relevant information before placing orders and should verify that such information is current and complete. All semiconductor products (also referred to herein as "components") are sold subject to TI's terms and conditions of sale supplied at the time of order acknowledgment.

TI warrants performance of its components to the specifications applicable at the time of sale, in accordance with the warranty in TI's terms and conditions of sale of semiconductor products. Testing and other quality control techniques are used to the extent TI deems necessary to support this warranty. Except where mandated by applicable law, testing of all parameters of each component is not necessarily performed.

TI assumes no liability for applications assistance or the design of Buyers' products. Buyers are responsible for their products and applications using TI components. To minimize the risks associated with Buyers' products and applications, Buyers should provide adequate design and operating safeguards.

TI does not warrant or represent that any license, either express or implied, is granted under any patent right, copyright, mask work right, or other intellectual property right relating to any combination, machine, or process in which TI components or services are used. Information published by TI regarding third-party products or services does not constitute a license to use such products or services or a warranty or endorsement thereof. Use of such information may require a license from a third party under the patents or other intellectual property of the third party, or a license from TI under the patents or other intellectual property of TI.

Reproduction of significant portions of TI information in TI data books or data sheets is permissible only if reproduction is without alteration and is accompanied by all associated warranties, conditions, limitations, and notices. TI is not responsible or liable for such altered documentation. Information of third parties may be subject to additional restrictions.

Resale of TI components or services with statements different from or beyond the parameters stated by TI for that component or service voids all express and any implied warranties for the associated TI component or service and is an unfair and deceptive business practice. TI is not responsible or liable for any such statements.

Buyer acknowledges and agrees that it is solely responsible for compliance with all legal, regulatory and safety-related requirements concerning its products, and any use of TI components in its applications, notwithstanding any applications-related information or support that may be provided by TI. Buyer represents and agrees that it has all the necessary expertise to create and implement safeguards which anticipate dangerous consequences of failures, monitor failures and their consequences, lessen the likelihood of failures that might cause harm and take appropriate remedial actions. Buyer will fully indemnify TI and its representatives against any damages arising out of the use of any TI components in safety-critical applications.

In some cases, TI components may be promoted specifically to facilitate safety-related applications. With such components, TI's goal is to help enable customers to design and create their own end-product solutions that meet applicable functional safety standards and requirements. Nonetheless, such components are subject to these terms.

No TI components are authorized for use in FDA Class III (or similar life-critical medical equipment) unless authorized officers of the parties have executed a special agreement specifically governing such use.

Only those TI components which TI has specifically designated as military grade or "enhanced plastic" are designed and intended for use in military/aerospace applications or environments. Buyer acknowledges and agrees that any military or aerospace use of TI components which have **not** been so designated is solely at the Buyer's risk, and that Buyer is solely responsible for compliance with all legal and regulatory requirements in connection with such use.

TI has specifically designated certain components as meeting ISO/TS16949 requirements, mainly for automotive use. In any case of use of non-designated products, TI will not be responsible for any failure to meet ISO/TS16949.

Products

Audio	www.ti.com/audio
Amplifiers	amplifier.ti.com
Data Converters	dataconverter.ti.com
DLP® Products	www.dlp.com
DSP	dsp.ti.com
Clocks and Timers	www.ti.com/clocks
Interface	interface.ti.com
Logic	logic.ti.com
Power Mgmt	power.ti.com
Microcontrollers	microcontroller.ti.com
RFID	www.ti-rfid.com
OMAP Applications Processors	www.ti.com/omap
Wireless Connectivity	www.ti.com/wirelessconnectivity

Applications

Automotive and Transportation	www.ti.com/automotive
Communications and Telecom	www.ti.com/communications
Computers and Peripherals	www.ti.com/computers
Consumer Electronics	www.ti.com/consumer-apps
Energy and Lighting	www.ti.com/energy
Industrial	www.ti.com/industrial
Medical	www.ti.com/medical
Security	www.ti.com/security
Space, Avionics and Defense	www.ti.com/space-avionics-defense
Video and Imaging	www.ti.com/video

TI E2E Community

e2e.ti.com