

GENERAL DESCRIPTION

The DS26303 is an 8-channel short-haul line interface unit (LIU) that supports E1/T1/J1 from a single 3.3V power supply. A wide variety of applications are supported through internal termination or external termination. A single bill of material can support E1/T1/J1 with minimum external components. Redundancy is supported through nonintrusive monitoring, optimal high-impedance modes, and configurable 1:1 or 1+1 backup enhancements. An on-chip synthesizer generates the E1/T1/J1 clock rates by a single master clock input of various frequencies. Two clock output references are also offered.

APPLICATIONS

- T1 Digital Cross-Connects
- ATM and Frame Relay Equipment
- Wireless Base Stations
- ISDN Primary Rate Interface
- E1/T1/J1 Multiplexer and Channel Banks
- E1/T1/J1 LAN/WAN Routers

FUNCTIONAL DIAGRAM

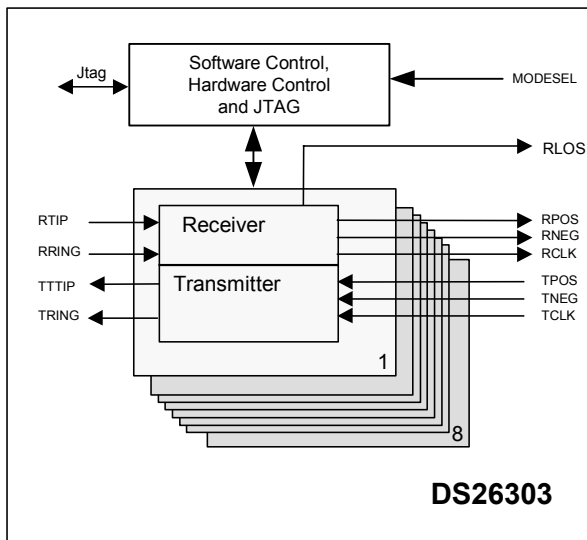

FEATURES

- 8 Complete E1, T1, or J1 Short Haul Line Interface Units
- Independent E1, T1, or J1 Selections
- Internal Software-Selectable Transmit and Receive-Side Termination
- Crystal-Less Jitter Attenuator
- Selectable Single-Rail and Dual-Rail Mode and AMI or HDB3/ B8ZS Line Encoding and Decoding
- Detection and Generation of AIS
- Digital/Analog Loss-of-Signal Detection as per T1.231, G.775, and ETSI 300233
- External Master Clock can be Multiple of 2.048MHz or 1.544MHz for T1/J1 or E1 Operation; This Clock will be Internally Adapted for T1 or E1 Use
- Built-In BERT Tester for Diagnostics
- 8-Bit Parallel Interface Support for Intel or Motorola Mode or a 4-Wire Serial Interface
- Hardware Mode Interface Support
- Transmit Short-Circuit Protection
- G.772 Nonintrusive Monitoring
- Specification Compliance to the Latest T1 and E1 Standards—ANSI T1.102, AT&T Pub 62411, T1.231, T1.403, ITU G.703, G.742, G.775, G.823, ETSI 300 166, and ETSI 300 233
- Single 3.3V Supply with 5V Tolerant I/O
- JTAG Boundary Scan as per IEEE 1149.1
- 160-Pin PBGA/144-Pin eLQFP Package

ORDERING INFORMATION

PART	TEMP RANGE	PIN-PACKAGE
DS26303G-XXX*	0°C to +70°C	160 PBGA
DS26303GN-XXX*	-40°C to +85°C	160 PBGA
DS26303L-XXX	0°C to +70°C	144 eLQFP
DS26303L-XXX+	0°C to +70°C	144 eLQFP
DS26303LN-XXX	-40°C to +85°C	144 eLQFP
DS26303LN-XXX+	-40°C to +85°C	144 eLQFP

Note: When XXX is 075, the part defaults to 75Ω impedance in E1 mode; when XXX is 120, the part defaults to 120Ω impedance.

+ Denotes a lead-free/ROHS-compliant device.

* Future product—contact factory for availability.

Note: Some revisions of this device may incorporate deviations from published specifications known as errata. Multiple revisions of any device may be simultaneously available through various sales channels. For information about device errata, click here: www.maxim-ic.com/errata.

TABLE OF CONTENTS

1	DETAILED DESCRIPTION	6
2	TELECOM SPECIFICATIONS COMPLIANCE.....	7
3	BLOCK DIAGRAMS	9
4	PIN DESCRIPTION	11
4.1	HARDWARE AND HOST PORT OPERATION	21
4.1.1	<i>Hardware Mode.....</i>	21
4.1.2	<i>Serial Port Operation</i>	22
4.1.3	<i>Parallel Port Operation.....</i>	23
4.1.4	<i>Interrupt Handling.....</i>	23
5	REGISTERS.....	25
5.1	REGISTER DESCRIPTION	30
5.1.1	<i>Primary Registers.....</i>	30
5.1.2	<i>Secondary Registers.....</i>	38
5.1.3	<i>Individual LIU Registers</i>	39
5.1.4	<i>BERT Registers</i>	46
6	FUNCTIONAL DESCRIPTION	53
6.1	POWER-UP AND RESET	53
6.2	MASTER CLOCK	53
6.3	TRANSMITTER	54
6.3.1	<i>Transmit Line Templates</i>	55
6.3.2	<i>LIU Transmit Front End.....</i>	57
6.3.3	<i>Dual-Rail Mode</i>	58
6.3.4	<i>Single-Rail Mode.....</i>	58
6.3.5	<i>Zero Suppression—B8ZS or HDB3</i>	58
6.3.6	<i>Transmit Power-Down</i>	58
6.3.7	<i>Transmit All Ones.....</i>	58
6.3.8	<i>Drive Failure Monitor.....</i>	58
6.4	RECEIVER.....	58
6.4.1	<i>Peak Detector and Slicer</i>	58
6.4.2	<i>Clock and Data Recovery</i>	59
6.4.3	<i>Loss of Signal.....</i>	59
6.4.4	<i>AIS</i>	60
6.4.5	<i>Bipolar Violation and Excessive Zero Detector.....</i>	61
6.4.6	<i>LIU Receiver Front End</i>	61
6.5	HITLESS-PROTECTION SWITCHING (HPS).....	61
6.6	JITTER ATTENUATOR	63
6.7	G.772 MONITOR	64
6.8	LOOPBACKS.....	64
6.8.1	<i>Analog Loopback</i>	64
6.8.2	<i>Digital Loopback.....</i>	64
6.8.3	<i>Remote Loopback.....</i>	65
6.9	BERT.....	66
6.9.1	<i>Configuration and Monitoring.....</i>	66
6.9.2	<i>Receive Pattern Detection</i>	67
6.9.3	<i>Transmit Pattern Generation.....</i>	68
6.10	SPECIAL TEST FUNCTIONS.....	69
6.10.1	<i>Metal Options.....</i>	69
7	JTAG BOUNDARY SCAN ARCHITECTURE AND TEST ACCESS PORT.....	70
7.1	TAP CONTROLLER STATE MACHINE.....	71
7.2	INSTRUCTION REGISTER	74
7.3	TEST REGISTERS	75
7.3.1	<i>Boundary Scan Register.....</i>	75

7.3.2	<i>Bypass Register</i>	75
7.3.3	<i>Identification Register</i>	75
8	OPERATING PARAMETERS	76
9	THERMAL CHARACTERISTICS	77
10	AC CHARACTERISTICS	78
10.1	LINE INTERFACE CHARACTERISTICS.....	78
10.2	PARALLEL HOST INTERFACE TIMING CHARACTERISTICS.....	79
10.3	SERIAL PORT.....	91
10.4	SYSTEM TIMING.....	92
10.5	JTAG TIMING.....	94
11	PACKAGE INFORMATION	95
11.1	ELQFP PACKAGE OUTLINE (1 OF 2).....	95
11.2	ELQFP PACKAGE OUTLINE (2 OF 2).....	96
12	DOCUMENT REVISION HISTORY	97

LIST OF FIGURES

Figure 3-1. Block Diagram	9
Figure 3-2. Receive Logic Detail.....	10
Figure 3-3. Transmit Logic Detail.....	10
Figure 4-1. 160-Pin PBGA Pin Assignment.....	19
Figure 4-2. 144-Pin eLQFP Pin Assignment	20
Figure 4-3. Serial Port Operation for Write Access	22
Figure 4-4. Serial Port Operation for Read Access with CLKE = 0	22
Figure 4-5. Serial Port Operation for Read Access with CLKE = 1	23
Figure 4-6. Interrupt Handling Flow Diagram	24
Figure 6-1. Pre-Scaler PLL and Clock Generator.....	53
Figure 6-2. T1 Transmit Pulse Templates	55
Figure 6-3 E1 Transmit Pulse Templates	56
Figure 6-4. LIU Front End	57
Figure 6-5. HPS Logic	62
Figure 6-6. HPS Block Diagram.....	62
Figure 6-7. Jitter Attenuation	63
Figure 6-8. Analog Loopback.....	64
Figure 6-9. Digital Loopback.....	65
Figure 6-10. Remote Loopback	65
Figure 6-11. PRBS Synchronization State Diagram.....	67
Figure 6-12. Repetitive Pattern Synchronization State Diagram.....	68
Figure 7-1. JTAG Functional Block Diagram	70
Figure 7-2. TAP Controller State Diagram.....	73
Figure 10-1. Intel Nonmuxed Read Cycle	80
Figure 10-2. Intel Mux Read Cycle	81
Figure 10-3. Intel Nonmux Write Cycle.....	83
Figure 10-4. Intel Mux Write Cycle	84
Figure 10-5. Motorola Nonmux Read Cycle	86
Figure 10-6. Motorola Mux Read Cycle.....	87
Figure 10-7. Motorola Nonmux Write Cycle	89
Figure 10-8. Motorola Mux Write Cycle	90
Figure 10-9. Serial Bus Timing Write Operation.....	91
Figure 10-10. Serial Bus Timing Read Operation with CLKE = 0.....	91
Figure 10-11. Serial Bus Timing Read Operation with CLKE = 1.....	91
Figure 10-12. Transmitter Systems Timing	92
Figure 10-13. Receiver Systems Timing	93
Figure 10-14. JTAG Timing	94

LIST OF TABLES

Table 2-1. T1-Related Telecommunications Specifications	7
Table 2-2. E1-Related Telecommunications Specifications	8
Table 4-1. Pin Descriptions	11
Table 4-2. Hardware Mode Configuration Examples	21
Table 4-3. Parallel Port Mode Selection and Pin Functions	23
Table 5-1. Primary Register Set	25
Table 5-2. Secondary Register Set	26
Table 5-3. Individual LIU Register Set	26
Table 5-4. BERT Register Set	27
Table 5-5. Primary Register Set Bit Map	28
Table 5-6. Secondary Register Set Bit Map	28
Table 5-7. Individual LIU Register Set Bit Map	28
Table 5-8. BERT Register Bit Map	29
Table 5-9. G.772 Monitoring Control	33
Table 5-10. TST Template Select Transmitter Register	35
Table 5-11. Template Selection	36
Table 5-12. Address Pointer Bank Selection	37
Table 5-13. MCLK Selections	41
Table 5-14. PLL Clock Select	44
Table 5-15. Clock A Select	44
Table 6-1. Telecommunications Specification Compliance for DS26303 Transmitters	54
Table 6-2. Registers Related to Control of DS26303 Transmitters	54
Table 6-3. DS26303 Template Selections	55
Table 6-4. LIU Front-End Values	57
Table 6-5. Loss Criteria T1.231, G.775, and ETSI 300 233 Specifications	59
Table 6-6. AIS Criteria T1.231, G.775, and ETSI 300 233 Specifications	60
Table 6-7. AIS Detection and Reset Criteria	60
Table 6-8. Registers Related to AIS Detection	60
Table 6-9. BPV, Code Violation, and Excessive Zero Error Reporting	61
Table 6-10. Pseudorandom Pattern Generation	66
Table 6-11. Repetitive Pattern Generation	66
Table 7-1. Instruction Codes for IEEE 1149.1 Architecture	74
Table 7-2. ID Code Structure	75
Table 7-3. Device ID Codes	75
Table 8-1. Recommended DC Operating Conditions	76
Table 8-2. Capacitance	76
Table 8-3. DC Characteristics	76
Table 9-1. Thermal Characteristics	77
Table 10-1. Transmitter Characteristics	78
Table 10-2. Receiver Characteristics	78
Table 10-3. Intel Read Mode Characteristics	79
Table 10-4. Intel Write Cycle Characteristics	82
Table 10-5. Motorola Read Cycle Characteristics	85
Table 10-6. Motorola Write Cycle Characteristics	88
Table 10-7. Serial Port Timing Characteristics	91
Table 10-8. Transmitter System Timing	92
Table 10-9. Receiver System Timing	93
Table 10-10. JTAG Timing Characteristics	94

1 DETAILED DESCRIPTION

The DS26303 is a single-chip, 8-channel, short-haul line interface unit (LIU) for T1 (1.544Mbps) and E1 (2.048Mbps) applications. Eight independent receivers and transmitters are provided in a single PBGA package or an eLQFP package. The LIUs can be individually selected for T1, J1, or E1 operation. The LIU requires a single reference clock called MCLK. MCLK can be either 1.544MHz or 2.048MHz or a multiple thereof, and either frequency can be internally adapted for T1, J1, or E1 mode. Internal impedance match provided for both transmit and receive paths reduces external component count. The transmit waveforms are compliant to G.703 and T1.102 specification. The DS26303 provides software-selectable internal transmit termination for 100 Ω T1 twisted pair, 110 Ω J1 twisted pair, 120 Ω E1 twisted pair, and 75 Ω E1 coaxial applications. The transmitters have fast high-impedance capability and can be individually powered down.

The receivers can function with up to 15dB of receive signal attenuation for T1 mode and E1 mode. The DS26303 can be configured as a 7-channel LIU with channel 1 used for nonintrusive monitoring in accordance with G.772. The receivers and transmitters can be programmed into single-rail or dual-rail mode. AMI or HDB/B8ZS encoding and decoding is selectable in single-rail mode. A 128-bit crystal-less on-board jitter attenuator for each LIU can be placed in the receive or transmit directions. The jitter attenuator meets the ETSI CTR12/13 ITU G.736, G.742, G.823, and AT&T PUB6411 specifications.

The DS26303 detects and generates AIS in accordance with T1.231, G.775, and ETSI 300233. Loss of signal is detected in accordance with T1.231, G.775, and ETSI 300233. The DS26303 can perform digital, analog, remote, and dual loopbacks on individual LIUs. JTAG boundary scan is provided for the digital pins.

The DS26303 can be configured using an 8-bit multiplexed or nonmultiplexed Intel or Motorola port, a 4-pin serial port, or in limited modes of operation using hardware mode.

The analog AMI/HDB3 waveform of the E1 line or the AMI/B8ZS waveform of the T1 line is transformer coupled into the RTIP and RRING pins of the DS26303. The user has the option to select internal termination of 75 Ω , 100 Ω , 110 Ω , or 120 Ω applications. The device recovers clock and data from the analog signal and passes it through a selectable jitter attenuator, outputting the received line clock at RCLK and data at RPOS and RNEG.

The DS26303 receivers can recover data and clock for up to 15dB of attenuation of the transmitted signals in T1 and E1 mode. Receiver 1 can monitor the performance of receivers 2 to 8 or transmitters 2 to 8.

The DS26303 contains eight identical transmitters. Digital transmit data is input at TPOS/TNEG with reference to TCLK. The data at these pins can be single rail or dual rail. This data is processed by waveshaping circuitry and line driver to output at TTIP and TRING in accordance with ANSI T1.102 for T1/J1 or G.703 for E1 mask.

The DS26303 drives the E1 or T1 line from the TTIP and TRING pins through a coupling transformer. The DS26303 functions with a 1:2 and 2:1 transformer for the Tx and Rx paths for operation, respectively.

2 TELECOM SPECIFICATIONS COMPLIANCE

The DS26303 LIU meets all the relevant latest telecommunications specifications. The following table provides the T1 specifications and relevant sections that are applicable to the DS26303.

Table 2-1. T1-Related Telecommunications Specifications

ANSI T1.102–Digital Hierarchy Electrical Interface
AMI Coding
B8ZS Substitution Definition
DS1 Electrical Interface. Line rate ± 32 ppm; Pulse Amplitude between 2.4V to 3.6 V peak; Power level between 12.6dBm to 17.9dBm. The T1 pulse mask is provided that we comply. DSX-1 for cross connects the return loss is greater than 26dB. The DSX-1 cable is restricted up to 655 feet.
This specification also provides cable characteristics of DSX-Cross Connect cable—22 AVG cable of 1000 feet.
ANSI T1.231–Digital Hierarchy–Layer 1 in Service Performance Monitoring
BPV Error Definition, Excessive Zero Definition, LOS description, AIS definition
ANSI T1.403–Network and Customer Installation Interface–DS1 Electrical Interface
Description of the Measurement of the T1 Characteristics—100 Ω , pulse shape and template according to T1.102; power level 12.4dBm to 19.7dBm when all ones are transmitted.
<i>LBO for the Customer Interface (CI) is specified as 0dB, 7.5dB, and 15dB. Line rate is ± 32ppm. Pulse Amplitude is 2.4V to 3.6 V.</i>
AIS generation as unframed all ones is defined.
<i>The total cable attenuation is defined as 22dB. The DS26303 functions up to 36dB cable loss.</i>
Note that the pulse mask defined by T1.403 and T1.102 are different—specifically at Times 0.61, -0.27, -34, and 0.77. The DS26303 is compliant to both templates.
Pub 62411
This specification has tighter jitter tolerance and transfer characteristics than other specifications. The jitter transfer characteristics are tighter than G.736 and jitter tolerance is tighter the G.823.

Table 2-2. E1-Related Telecommunications Specifications

ITU G.703 Physical/Electrical Characteristics of G.703 Hierarchical Digital Interfaces	
Defines the 2048kbps bit rate: 2048 ± 50 ppm. The transmission media are 75Ω coax or 120Ω twisted pair; peak-to-peak space voltage is ± 0.237 V; nominal pulse width is 244ns.	
Return loss: 51Hz to 102Hz is 6dB, 102Hz to 3072Hz is 8dB, 2048Hz to 3072Hz is 14dB	
Nominal peak voltage is 2.37V for coax and 3V for twisted pair.	
The pulse mask for E1 is defined in G.703.	
ITU G.736 Characteristics of Synchronous Digital Multiplex Equipment Operating at 2048kbps	
The peak-to-peak jitter at 2048kbps must be less than 0.05UI at 20Hz to 100Hz.	
Jitter transfer between 2.048 synchronization signal and 2.048 transmission signal is provided.	
ITU G.742 Second-Order Digital Multiplex Equipment Operating at 8448kbps	
The DS26303 jitter attenuator is compliant with jitter transfer curve for sinusoidal jitter input.	
ITU G.772	
This specification provides the method for using receiver for transceiver 0 as a monitor for the rest of the seven transmitter/receiver combinations.	
ITU G.775	
An LOS detection criterion is defined.	
ITU G.823—The control of jitter and wander within digital networks that are based on 2.048kbps Hierarchy	
G.823 provides the jitter amplitude tolerance at different frequencies, specifically 20Hz, 2.4kHz, 18kHz, and 100kHz.	
ETSI 300 166	
This specification provides transmit return loss of 6dB for a range of 0.25fb to 0.05fb, and 8dB for a range of 0.05fb to 1.5fb where fb equals 2.048kHz for 2.048kbps interface.	
ETSI 300 233	
This specification provides LOS and AIS signal criteria for E1 mode.	
Pub 62411	
This specification has tighter jitter tolerance and transfer characteristics than other specifications. The jitter transfer characteristics are tighter than G.736 and jitter tolerance is tighter than G.823.	

3 BLOCK DIAGRAMS

Figure 3-1. Block Diagram

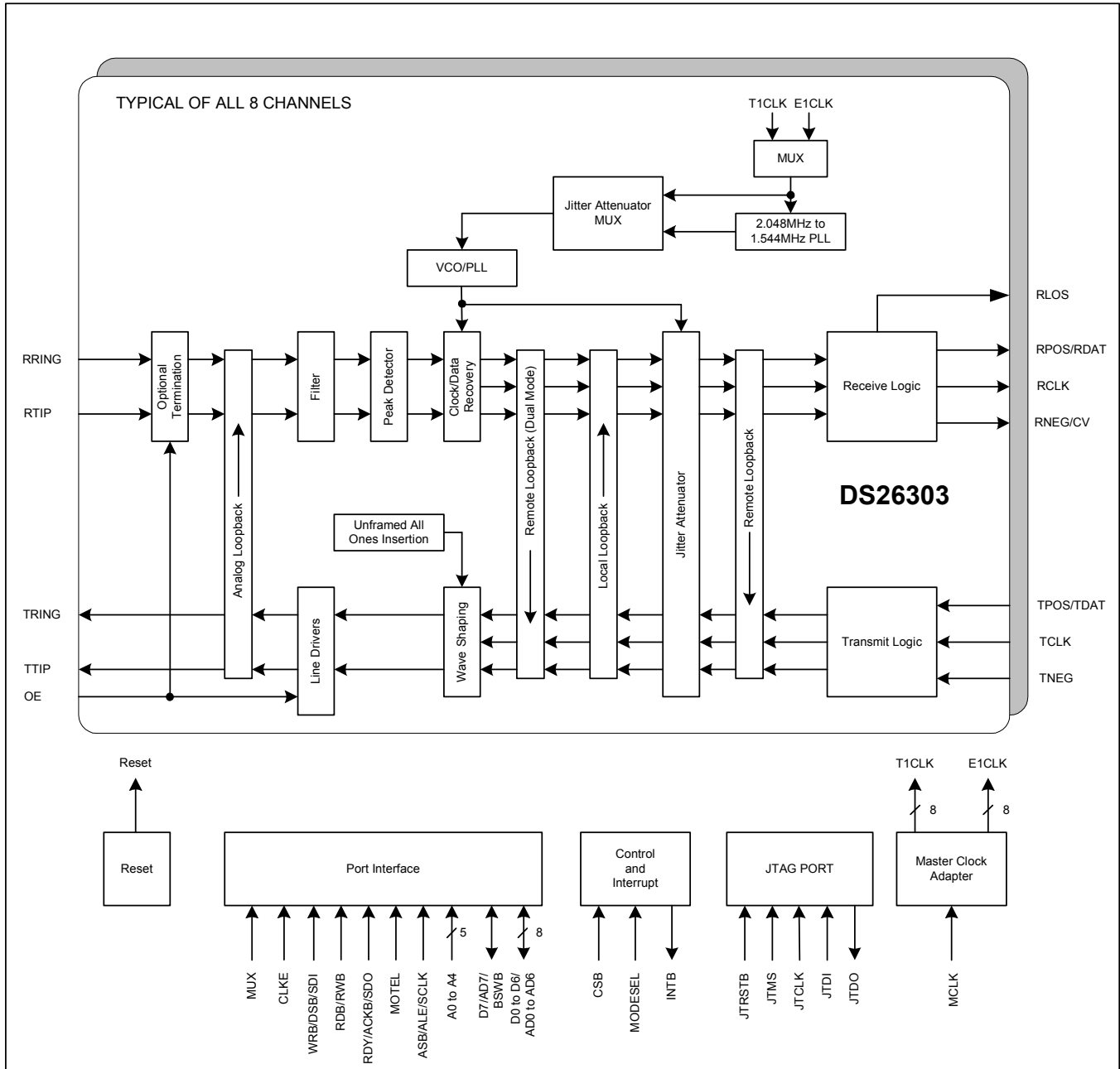

Figure 3-2. Receive Logic Detail

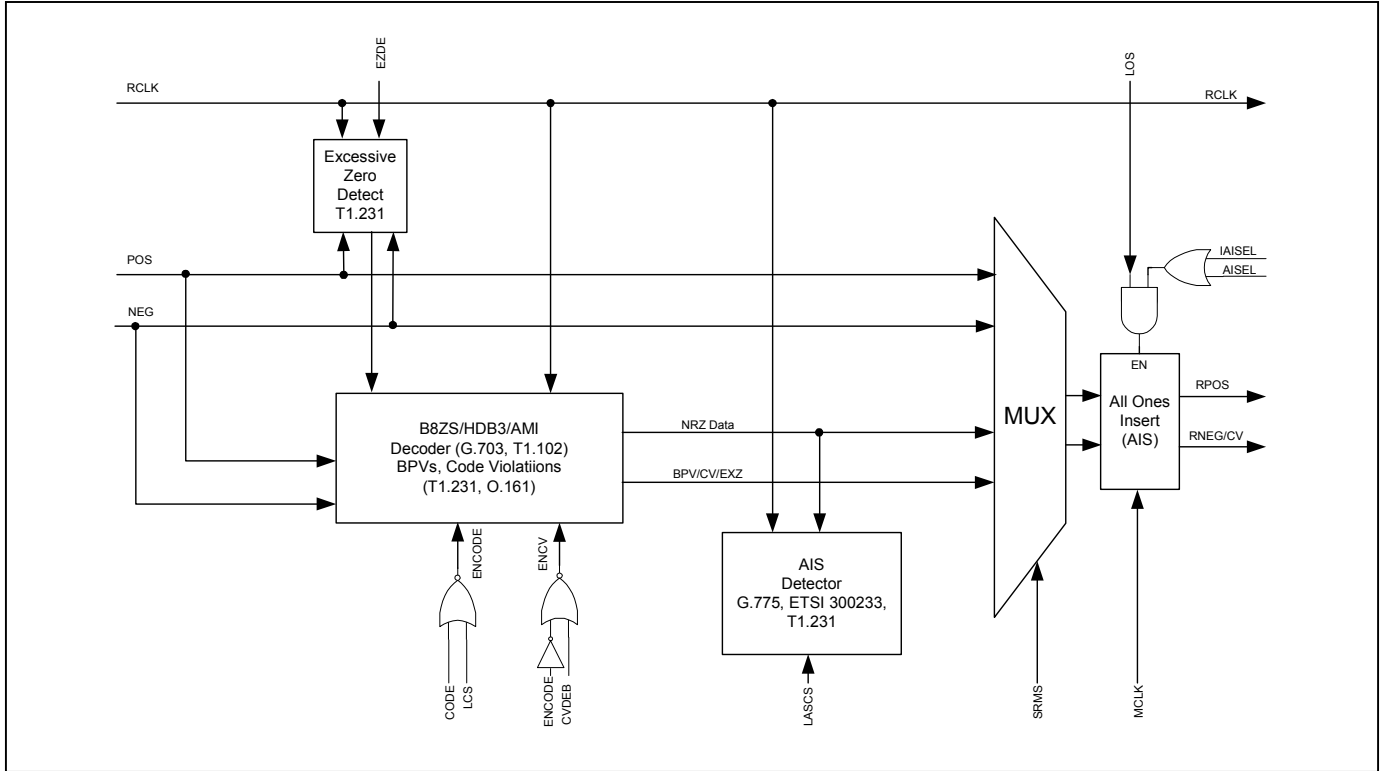
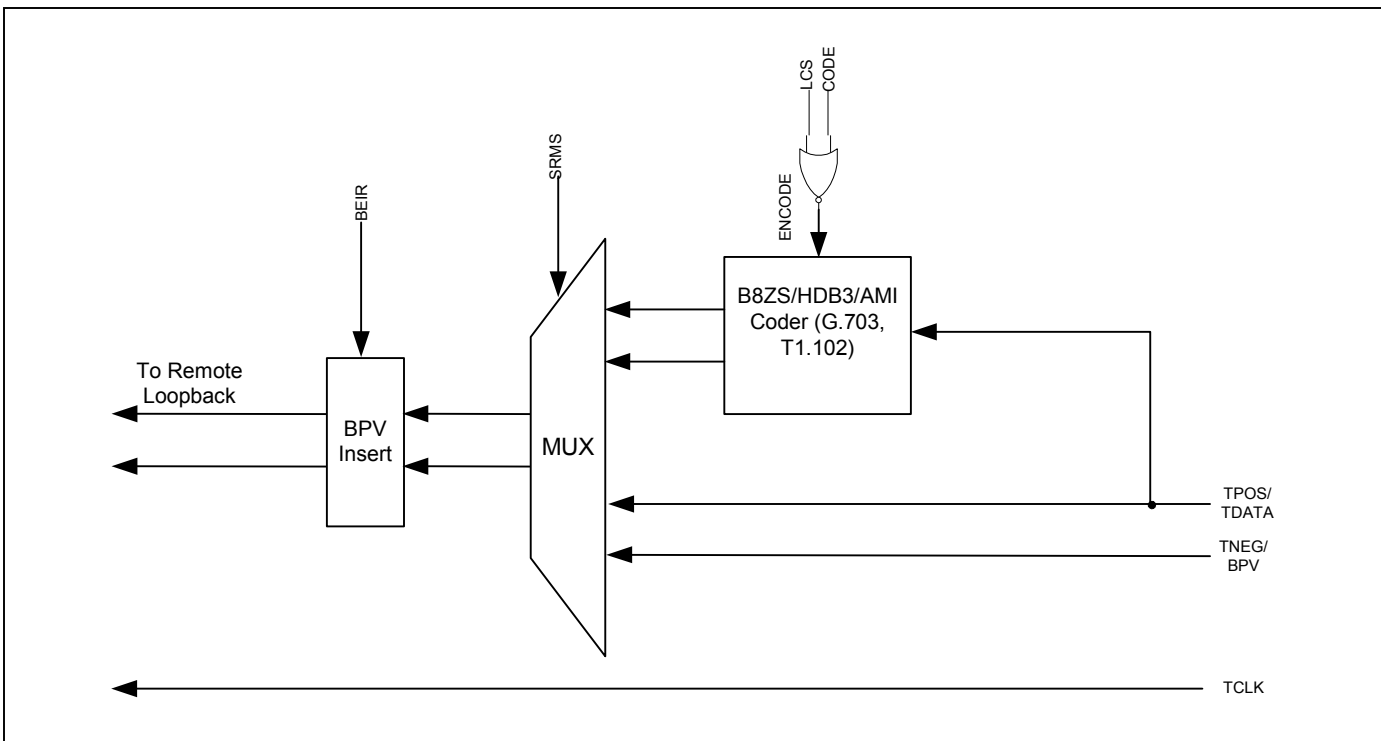

Figure 3-3. Transmit Logic Detail



4 PIN DESCRIPTION

Table 4-1. Pin Descriptions

NAME	PIN		TYPE	FUNCTION
	eLQFP	PBGA		
ANALOG TRANSMIT AND RECEIVE				
TTIP1	45	N5	Analog Output	Transmit Bipolar Tip for Channel 1 to 8. These pins are differential line-driver tip outputs. These pins can be high impedance if pin OE is low. If the corresponding clock TCLKn is low for 64 MCLKs, where n is 1 to 8 for the eight transmitters. This puts the corresponding transmitter in a power-down mode. When 1 is set in the OEB .OEB bit, the associated pin is high impedance. The differential outputs of TTIPn and TRINGn can provide internal matched impedance for E1 75Ω, E1 120Ω, T1 100Ω, or J1 110Ω.
TTIP2	52	L5		
TTIP3	57	L10		
TTIP4	64	N10		
TTIP5	117	B10		
TTIP6	124	D10		
TTIP7	129	D5		
TTIP8	136	B5		
TRING1	46	P5	Analog Output	Transmit Bipolar Ring for Channel 1 to 8. These pins are differential line-driver ring outputs. These pins can be high impedance if pin OE is low. If the corresponding clock TCLKn is low for 64 MCLKs, where n is 1 to 8 for the eight transmitters. This puts the corresponding transmitter in a power-down mode. When 1 is set in the OEB.OEB bit, the associated pin is high impedance. The differential outputs of TTIPn and TRINGn can provide internal matched impedance for E1 75Ω, E1 120Ω, T1 100Ω, or J1 110Ω.
TRING2	51	M5		
TRING3	58	M10		
TRING4	63	P10		
TRING5	118	A10		
TRING6	123	C10		
TRING7	130	C5		
TRING8	135	A5		
RTIP1	48	P7	Analog Input	Receive Bipolar Tip for Channel 1 to 8. Receive analog input for differential receiver. Data and clock are recovered and output at RPOS/RNEG and RCLK pins, respectively. The differential inputs of RTIPn and RRINGn can provide internal matched impedance for E1 75Ω, E1 120Ω, T1 100Ω, or J1 110Ω.
RTIP2	55	M7		
RTIP3	60	M8		
RTIP4	67	P8		
RTIP5	120	A8		
RTIP6	127	C8		
RTIP7	132	C7		
RTIP8	139	A7		
RRING1	49	N7	Analog Input	Receive Bipolar Ring for Channel 1 to 8. Receive analog input for differential receiver. Data and clock are recovered and output at RPOS/RNEG and RCLK pins, respectively. The differential inputs of RTIPn and RRINGn can provide internal matched impedance for E1 75Ω, E1 120Ω, T1 100Ω, or J1 110Ω.
RRING2	54	L7		
RRING3	61	L8		
RRING4	66	N8		
RRING5	121	B8		
RRING6	126	D8		
RRING7	133	D7		
RRING8	138	B7		

NAME	PIN		TYPE	FUNCTION															
	eLQFP	PBGA																	
DIGITAL Tx/Rx																			
TPOS1/TDATA1	37	N2	I	Transmit Positive-Data Input for Channel 1 to 8/Transmit Data Input for Channel 1 to 8 <i>TPOS[1:8]</i> : When the DS26303 is configured in dual-rail mode, the data input to TPOS _n is output as a positive pulse on the line (TIP and RING). <i>TDATA[1:8]</i> : When the device is configured in single-rail mode, NRZ data is input to TDATAn. The data is encoded HDB3/B8ZS or AMI before being output to the line.															
TPOS2/TDATA2	30	L2																	
TPOS3/TDATA3	80	L13																	
TPOS4/TDATA4	73	N13																	
TPOS5/TDATA5	108	B13																	
TPOS6/TDATA6	101	D13																	
TPOS7/TDATA7	8	D2																	
TPOS8/TDATA8	1	B2																	
TNEG1	38	N3	I	Transmit Negative Data for Channel 1 to 8. When the DS26303 is configured in dual-rail mode, the data input to TNEG _n is output as a negative mark on the line as follows: <table border="1"> <thead> <tr> <th>TPOS_n</th> <th>TNEG_n</th> <th>Output Pulse</th> </tr> </thead> <tbody> <tr> <td>0</td> <td>0</td> <td>Space</td> </tr> <tr> <td>0</td> <td>1</td> <td>Negative Mark</td> </tr> <tr> <td>1</td> <td>0</td> <td>Positive Mark</td> </tr> <tr> <td>1</td> <td>1</td> <td>Space</td> </tr> </tbody> </table> When TNEG _n is pulled High for more than 16 consecutive TCLK clock cycles, single-rail I/O is selected.	TPOS _n	TNEG _n	Output Pulse	0	0	Space	0	1	Negative Mark	1	0	Positive Mark	1	1	Space
TPOS _n	TNEG _n	Output Pulse																	
0	0	Space																	
0	1	Negative Mark																	
1	0	Positive Mark																	
1	1	Space																	
TNEG2	31	L3																	
TNEG3	79	L12																	
TNEG4	72	N12																	
TNEG5	109	B12																	
TNEG6	102	D12																	
TNEG7	7	D3																	
TNEG8	144	B3																	
TCLK1	36	N1	I	Transmit Clock for Channel 1 to 8. The transmit clock must be 1.544MHz for T1 or 2.048MHz for E1 mode. TCLK _n is the clock used to sample the data TPOS/TNEG or TDAT on the falling edge. The expected TCLK can be inverted. If TCLK _n is high for 16 or more MCLKs, then transmit all-ones (TAO) signals to the line side of the corresponding transmit channel. When TCLK _n starts clocking again, normal operation will begin again for the corresponding transmit channel. If TCLK _n is low for 64 or more MCLKs, the corresponding transmit channel on the line side powers down and must be put into high impedance. When TCLK _n starts clocking again the corresponding transmit channel powers up and comes out of high impedance.															
TCLK2	29	L1																	
TCLK3	81	L14																	
TCLK4	74	N14																	
TCLK5	107	B14																	
TCLK6	100	D14																	
TCLK7	9	D1																	
TCLK8	2	B1																	
RPOS1/RDATA1	40	P2	O, tri-state	Receive Positive-Data Output for Channel 1 to 8/Receive Data Output for Channel 1 to 8 <i>RPOS[1:8]</i> : In dual-rail mode, the NRZ data output indicates a positive pulse on RTIP/RRING. If a given receiver is in power-down mode, the associated RPOS pin is high impedance. <i>RDATA[1:8]</i> : In single-rail mode, NRZ data is output to the pin. Note: During an RLOS condition, the RPOS/RDATA outputs remain active.															
RPOS2/RDATA2	33	M2																	
RPOS3/RDATA3	77	M13																	
RPOS4/RDATA4	70	P13																	
RPOS5/RDATA5	111	A13																	
RPOS6/RDATA6	104	C13																	
RPOS7/RDATA7	5	C2																	
RPOS8/RDATA8	142	A2																	
RNEG1/CV1	41	P3	O, tri-state	Receive Negative-Data Output for Channel 1 to 8/Code Violation for Channel 1 to 8 <i>RNEG[1:8]</i> : In dual-rail mode, the NRZ data output indicates a negative pulse on RTIP/RRING. If a given receiver is in power-down mode, the associated RNEG pin is high impedance. <i>CV[1:8]</i> : In single-rail mode, bipolar violation, code violation, and excessive zeros are reported by driving CV _n high for one clock															
RNEG2/CV2	34	M3																	
RNEG3/CV3	76	M12																	
RNEG4/CV4	69	P12																	
RNEG5/CV5	112	A12																	

NAME	PIN		TYPE	FUNCTION
	eLQFP	PBGA		
RNEG6/CV6	105	C12		excessive zeros are reported by driving CVn high for one clock cycle. If HDB3 or B8ZS is not selected, this pin indicates only BPVs. Note: During an RLOS condition the output remains active.
RNEG7/CV7	4	C3		
RNEG8/CV8	141	A3		
RCLK1	39	P1	O, tri-state	Receive Clock for Channel 1 to 8. The receive data RPOS/RNEG or RDAT is clocked out on the rising edge of RCLK. RCLK output can be inverted. If a given receiver is in power-down mode, the RCLK is high impedance.
RCLK2	32	M1		
RCLK3	78	M14		
RCLK4	71	P14		
RCLK5	110	A14		
RCLK6	103	C14		
RCLK7	6	C1		
RCLK8	143	A1		
MCLK	10	E1	I	Master Clock. This is an independent free-running clock that can be a multiple of 2.048MHz \pm 50ppm for E1 mode or 1.544MHz \pm 50ppm for T1 mode. The clock selection is available by MC bits MPS0, MPS1, FREQS, and PLLE. A multiple of 2.048MHz can be internally adapted to 1.544MHz and a multiple of 1.544MHz can be internally adapted to 2.048MHz. In hardware mode, internal adaptation is not available so the user must provide 2.048MHz \pm 50ppm for E1 mode or 1.544MHz \pm 50ppm for T1 mode.
RLOS1/TECLK	42	K4	O	Loss-of-Signal Output/T1-E1 Clock <i>RLOS1:</i> This output goes high when there is no transition on the received signal over a specified interval. The output goes low when there is sufficient ones density in the received signal. The RLOS criteria for assertion and desertion criteria are described in the <i>Functional Description</i> section. The RLOS outputs can be configured to comply with T1.231, ITU G.775, or ETSI 300 233. In hardware mode, ETSI 300 233 "RLOS Criteria" is not available. <i>TECLK:</i> When enabled by register MC , this output becomes a T1- or E1-programmable clock output. For T1 or E1 frequency selection, see register CCR . This option is not available in hardware mode.
RLOS2/ RXPROBEA1	35	K3	I/O	Loss-of-Signal Output/Receive Probe <i>RLOS[2:4]:</i> See RLOS1 pin description. <i>RXPROBE A1, B1, C1:</i> Used in test only.
RLOS3/ RXPROBEB1	75	K12		
RLOS4/ RXPROBEC1	68	K11		
RLOS5/ scan_do	113	E11	O	Loss-of-Signal Output/Scan Data Output <i>RLOS5:</i> See RLOS1 pin description. <i>scan_do:</i> Data output during scan.
RLOS6/ scan_di	106	E12	I/O	Loss-of-Signal Output/Scan Data Input <i>RLOS6:</i> See RLOS1 pin description. <i>scan_di:</i> Data input during scan.
RLOS7/ scan_clk	3	E3	I/O	Loss-of-Signal Output/Scan Clock <i>RLOS7:</i> See RLOS1 pin description. <i>scan_clk:</i> Clock input during scan.

NAME	PIN		TYPE	FUNCTION
	eLQFP	PBGA		
RLOS8/ scan_en	140	E4	I/O	Loss-of-Signal Output/Scan Enable <i>RLOS8</i> : See RLOS1 pin description. <i>scan_en</i> : Enables scan during test when pin <i>scan_mode</i> is high.
CLKA	93	G13	O, tri-state	Clock A . This output becomes a programmable clock output when enabled by register MC . For frequency options see register CCR . This option is not available in hardware mode. If this option is not used, the pin should be left unconnected.
scan_mode	94	H13	I (pulled to V _{SS})	Scan Mode . Selects scan mode when high. If not used, this pin should be left unconnected or grounded.
HARDWARE AND PORT OPERATION				
MODESEL	11	E2	I (pulled to V _{DD} /2)	Mode Selection . This pin is used to select the control mode of the DS26303. Low → Hardware Mode V _{DD} /2 → Serial Host Mode High → Parallel Host Mode Note: When left unconnected, do not route signals with fast transitions near MODESEL. This practice minimizes capacitive coupling.
MUX/ TIMPRM	43	K2	I	Multiplexed/Nonmultiplexed Select Pin/ Transmit Impedance/Receive Impedance Match <i>MUX</i> : In host mode with a parallel port, this pin is used to select multiplexed address and data operation or separate address and data. When mux is a high, multiplexed address and data is used. <i>TIMPRM</i> : In hardware mode, this pin selects the internal transmit termination impedance and receive impedance match for E1 mode and T1/J1 mode. 0 → 75Ω for E1 mode or 100Ω for T1 mode 1 → 120Ω for E1 mode or 110Ω for J1 mode Note: If the part number ends with 120, the default is 120Ω when low and 75Ω when high for E1 mode only.
MOTEL/ CODE	88	H12	I	Motorola Intel Select/Code <i>MOTEL</i> : When in parallel host mode, this pin selects Motorola mode when low and Intel mode when high. <i>CODE</i> : In hardware mode, AMI encoding/decoding is selected when the pin is high for all the LIUs. When the pin is low, B8ZS is selected for T1 mode and HDB3 for E1 mode for all the LIUs.

NAME	PIN		TYPE	FUNCTION
	eLQFP	PBGA		
CSB/ JAS	87	J11	I (In HW mode, pulled to $V_{DD}/2$)	<p>Chip Select Bar/Jitter Attenuator Select</p> <p>CSB: This signal must be low during all accesses to the registers.</p> <p>JAS: In hardware mode, this pin is used as a jitter attenuator select.</p> <p>Low → Jitter attenuator is in the transmit path. VDDIO/2 → Jitter attenuator is not used. High → Jitter attenuator is in the receive path.</p> <p>Note: When left unconnected and in hardware mode, do not route signals with fast transitions near JAS. This practice minimizes capacitive coupling.</p>
SCLK/ALE/ ASB/TS2	86	J12	I	<p>Shift Clock/Address Latch Enable/Address Strobe Bar/Template Selection 2</p> <p>SCLK: In the serial host mode, this pin is the serial clock. Data on SDI is clocked on the rising edge of SCLK. The data is clocked on SDO on the rising edge of SCLK if CLKE is high. If CLKE is low the data on SDO is clocked on the falling edge of SCLK.</p> <p>ALE: In parallel Intel multiplexed mode, the address lines are latched on the falling edge of ALE. Tie ALE pin high if using nonmultiplexed mode.</p> <p>ASB: In parallel Motorola multiplexed mode, the address is sampled on the falling edge of ASB. Tie ASB pin high if using nonmultiplexed mode.</p> <p>TS2: In hardware mode, this pin signal is the most significant bit position in Table 5-11.</p>
RDB/RWB/TS1	85	J13	I	<p>Read Bar/Read Write Bar/Template Selection 1</p> <p>RDB: In Intel host mode, this pin must be low for read operation.</p> <p>RWB: In Motorola mode, this pin is low for write operation and high for read operation.</p> <p>TS1: In hardware mode, this pin signal is the second significant bit position in Table 5-11.</p>
SDI/WRB/DSB/TS0	84	J14	I	<p>Serial Data Input/Write Bar/Data Strobe Bar/Template Selection 0</p> <p>SDI: In the serial host mode, this pin is the serial input SDI. It is sampled on the rising edge of SCLK.</p> <p>WRB: In Intel host mode, this pin is active low during write operation. The data or address (multiplexed mode) is sampled on the rising edge of WRB.</p> <p>DSB: In the parallel Motorola mode, this pin is active low. During a write operation the data or address is sampled on the rising edge of DSB. During a read operation the data (D[7:0] or AD[7:0]) is driven on the rising edge of DSB. In the nonmultiplexed Motorola mode, the address bus (A [5:0]) is latched on the falling edge of DSB.</p> <p>TS0: In hardware mode, this pin signal is the least significant bit position in Table 5-11.</p>

NAME	PIN		TYPE	FUNCTION
	eLQFP	PBGA		
SDO/RDY/ACKB/ RIMPOFF	83	K14	I/O	<p>Serial Data Out/Ready Output/Acknowledge Bar/Receive Impedance Off</p> <p><i>SDO</i>: In serial host mode, the SDO data is output on this pin. If a serial write is in progress this pin is in high impedance. During a read SDO is high impedance when the SDI is in command/address mode. If CLKE is low, SDO is output on the rising edge of SCLK, if CLKE is high on the falling edge.</p> <p><i>RDY</i>: A low on this pin reports to the host that the cycle is not complete and wait states must be inserted. A high means the cycle is complete.</p> <p><i>ACKB</i>: In Motorola parallel mode, a low on this pin indicates that the read data is available for the host or that the written data cycle is complete.</p> <p><i>RIMPOFF</i>: In hardware mode when this pin is high, all the RTIP and RING pins have internal impedance switched off.</p>
$\overline{\text{INTB}}$	82	K13	O, open drain	<p>Active-Low Interrupt Bar. This interrupt signal is driven low when an event is detected on any of the enabled interrupt sources in any of the register banks. When there are no active and enabled interrupt sources, the pin can be programmed to either drive high or not drive high. The reset default is to not drive high when there are no active enabled interrupt sources. All interrupt sources are disabled after a software reset and they must be programmed to be enabled.</p>
D7/AD7/BSWP/LP8	28	K1	I/O (In HW mode, pulled to $V_{DD} / 2$)	<p>Data Bus 7–0/Address/Data Bus 7–0/Bit Swap/ Loopback Select 7–0</p> <p><i>D[7:0]</i>: In nonmultiplexed host mode, these pins are the bidirectional data bus.</p> <p><i>AD[7:0]</i>: In multiplexed host mode, these pins are the bidirectional address/data bus. Note that AD7 and AD6 do not carry address information, and in serial host mode AD6–AD0 should be grounded.</p> <p><i>BSWP</i>: In serial host mode, this pin defines the serial data position to be LSB first when low and MSB first when high.</p> <p><i>LP[8:1]</i> In hardware mode, these pins set the loopback modes for the corresponding LIU as follows:</p> <p>Low → Remote Loopback $V_{DDIO} / 2$ → No Loopback High → Analog Loopback</p> <p>Note: When left unconnected and in hardware mode, do not route signals with fast transitions near LP1–LP8. This practice minimizes capacitive coupling.</p>
D6/AD6/LP7	27	J1		
D5/AD5/LP6	26	J2		
D4/AD4/LP5	25	J3		
D3/AD3/LP4	24	J4		
D2/AD2/LP3	23	H2		
D1/AD1/LP2	22	H3		
D0/AD0/LP1	21	G2		

NAME	PIN		TYPE	FUNCTION
	eLQFP	PBGA		
A4/RIMPMSB	12	F4	I	<p>Address Bus 4–0/G.772 Monitoring Control/Rx Impedance Mode Select</p> <p><i>A[4:0]:</i> These five pins are address pins in parallel host mode. In serial host mode and multiplexed host mode, these pins should be grounded.</p> <p><i>RIMPMSB:</i> In hardware mode when this pin is low, the internal impedance mode is selected, so RTIP and RING require no external resistance component. When high, external impedance mode is selected so RTIP and RING require external resistance.</p> <p><i>GMC[3:0]:</i> In hardware mode, these signal pins are used to select transmitter or receiver for nonintrusive monitoring. Receiver 1 is used to monitor channels 2 to 8 of one receiver from RTIP2–RTIP8/RRING2–RRING8 or one transmitter from TTIP2–TTIP8/TRING2–TRING8. These signal pins correspond to the bits in Table 5-9.</p>
A3/GMC3	13	F3		
A2/GMC2	14	F2		
A1/GMC1	15	F1		
A0/GMC0	16	G3		
OE	114	E14	I	<p>Output Enable. If this pin is pulled low, all the transmitter outputs (TTIP and TRING) are high impedance. Additionally, the user may use this same pin to turn off all the impedance matching for the receivers at the same time if register bit GMR.RHPMC is set.</p>
CLKE	115	E13	I	<p>Clock Edge. When CLKE is high, SDO is valid on the falling edge of SCLK. When CLKE is low SDO is valid on the rising edge of SCLK. When CLKE is high, the RCLK for all the channels is inverted. This aligns RPOS/RNEG on the falling edge of RCLK and overrides the settings in register RCLKI. When low, RPOS/RNEG is aligned on the settings in register RCLKI.</p>
JTAG				
JTRSTB	95	G12	I, pullup	<p>JTAG Test Port Reset. This pin if low resets the JTAG port. If not used it can be left floating.</p>
JTMS	96	F11	I, pullup	<p>JTAG Test Mode Select. This pin is clocked on the rising edge of JTCLK and is used to control the JTAG selection between scan and test machine control.</p>
JTCLK	97	F14	I	<p>JTAG Test Clock. The data JTDI and JTMS are clocked on rising edge of JTCLK and JTDO is clocked out on the falling edge of JTCLK.</p>
JTDO	98	F13	O, high-Z	<p>JTAG Test Data Out. This is the serial output of the JTAG port. The data is clocked out on the falling edge of JTCLK.</p>
JTDI	99	F12	I, pullup	<p>Test Data Input. This pin input is the serial data of the JTAG test. The data on JTDI is clocked on the rising edge of JTCLK. This pin can be left unconnected.</p>
POWER SUPPLIES				
DVDD	19	H1	—	3.3V Digital Power Supply
DVSS	20	H4	—	Digital Ground
VDDIO	17, 92	G1, G14	—	3.3V I/O Power Supply
VSSIO	18, 91	G4, G11	—	I/O Ground

NAME	PIN		TYPE	FUNCTION
	eLQFP	PBGA		
TVDD1	44	N4, P4	—	3.3V Power Supply for the Transmitter. All TVDD pins must be connected to TVDD, which must be 3.3V.
TVDD2	53	L4, M4		
TVDD3	56	L11, M11		
TVDD4	65	N11, P11		
TVDD5	116	A11, B11		
TVDD6	125	C11, D11		
TVDD7	128	C4, D4		
TVDD8	137	A4, B4		
TVSS1	47	N6, P6	—	Analog Ground for Transmitters
TVSS2	50	L6, M6		
TVSS3	59	L9, M9		
TVSS4	62	N9, P9		
TVSS5	119	A9, B9		
TVSS6	122	C9, D9		
TVSS7	131	C6, D6		
TVSS8	134	A6, B6		
AVDD	90	H14	—	3.3V Analog Core Power Supply
AVSS	89	H11	—	Analog Core Ground

Figure 4-1. 160-Pin PBGA Pin Assignment

	14	13	12	11	10	9	8	7	6	5	4	3	2	1
A	RCLK5	RPOS5/ RDATA5	RNEG5/ CV5	TVDD5	TRING5	TVSS5	RTIP5	RTIP8	TVSS8	TRING8	TVDD8	RNEG8/ CV8	RPOS8/ RDATA8	RCLK8
B	TCLK5	TPOS5/ TDATA5	TNEG5	TVDD5	TTIP5	TVSS5	RRING5	RRING8	TVSS8	TTIP8	TVDD8	TNEG8	TPOS8/ TDATA8	TCLK8
C	RCLK6	RPOS6/ RDATA6	RNEG6/ CV6	TVDD6	TRING6	TVSS6	RTIP6	RTIP7	TVSS7	TRING7	TVDD7	RNEG7/ CV7	RPOS7/ RDATA7	RCLK7
D	TCLK6	TPOS6/ TDATA6	TNEG6	TVDD6	TTIP6	TVSS6	RRING6	RRING7	TVSS7	TTIP7	TVDD7	TNEG7	TPOS7/ TDATA7	TCLK7
E	OE	CLKE	RLOS6/ scan_di	RLOS5/ scan_do	DS26303 HARDWARE MODE (BOTTOM VIEW)						RLOS8/ scan_en	RLOS7/ scan_clk	MODESEL	MCLK
F	JTCLK	JTDO	JTDI	JTMS							A4	GMC3	GMC2	GMC1
G	VDDIO	CLKA	JTRSTB	GNDIO1							GNDIO0	GMC0	LP1	VDDIO0
H	AVDD	scan_mode	MOTEL/ CODE	AVSS							DVSS	LP2	LP3	DVDD
J	TS0	TS1	TS2	CSB/ JAS							LP4	LP5	LP6	LP7
K	SDO	INTB	RLOS3/ RXPROBE B1	RLOS4/ RXPROBE C1							RLOS1/ TECLK	RLOS2/ RXPROBE A1	MUX/ TIMPRM	LP8
L	TCLK3	TPOS3/ TDATA3	TNEG3	TVDD3							TTIP3	TVSS3	RRING3	RRING2
M	RCLK3	RPOS3/ RDATA3	RNEG3/ CV3	TVDD3	TRING3	TVSS3	RTIP3	RTIP2	TVSS2	TRING2	TVDD2	RNEG2/ CV2	RPOS2/ RDATA2	RCLK2
N	TCLK4	TPOS4/ TDATA4	TNEG4	TVDD4	TTIP4	TVSS4	RRING4	RRING1	TVSS1	TTIP1	TVDD1	TNEG1	TPOS1/ TDATA1	TCLK1
P	RCLK4	RPOS4/ RDATA4	RNEG4/ CV4	TVDD4	TRING4	TVSS4	RTIP4	RTIP1	TVSS1	TRING1	TVDD1	RNEG1/ CV1	RPOS1/ RDATA1	RCLK1

Figure 4-2. 144-Pin eLQFP Pin Assignment

NAME	PIN	NAME	PIN	NAME	PIN	NAME	PIN
TPOS8/TDATA8	1	TPOS1/TDATA1	37	TPOS4/TDATA4	73	TNEG5	109
TCLK8	2	TNEG1	38	TCLK4	74	RCLK5	110
RLOS7	3	RCLK1	39	RLOS3/RXPROBEB1	75	RPOS5/RDATA5	111
RNEG7/CV7	4	RPOS1/RDATA1	40	RNEG3/CV3	76	RNEG5/CV5	112
RPOS7/RDATA7	5	RNEG1/CV1	41	RPOS3/RDATA3	77	RLOS5	113
RCLK7	6	RLOS1/TECLK	42	RCLK3	78	OE	114
TNEG7	7	MUX/TIMPRM	43	TNEG3	79	CLKE	115
TPOS7/TDATA7	8	TVDD1	44	TPOS3/TDATA3	80	TVDD5	116
TCLK7	9	TTIP1	45	TCLK3	81	TTIP5	117
MCLK	10	TRING1	46	INTB	82	TRING5	118
MODESEL	11	TVSS1	47	SD0/RDY/ACKB/ RIMOFF	83	TVSS5	119
A4/RIMPMSB	12	RTIP1	48	SDI/WRB/DSB/TS0	84	RTIP5	120
A3/GMC3	13	RRING1	49	RDB/RWB/TS1	85	RRING5	121
A2/GMC2	14	TVSS2	50	SCLK/ALE/ASB/TS2	86	TVSS6	122
A1/GMC1	15	TRING2	51	CSB/JAS	87	TRING6	123
A0/GMC0	16	TTIP2	52	MOTEL/CODE	88	TTIP6	124
VDDIO	17	TVDD2	53	AVSS	89	TVDD6	125
VSSIO	18	RRING2	54	AVDD	90	RRING6	126
DVDD	19	RTIP2	55	VSSIO	91	RTIP6	127
DVSS	20	TVDD3	56	VDDIO	92	TVDD7	128
D0/AD0/LP1	21	TTIP3	57	CLKA	93	TTIP7	129
D1/AD1/LP2	22	TRING3	58	scan_mode	94	TRING7	130
D2/AD2/LP3	23	TVSS3	59	JTRSTB	95	TVSS7	131
D3/AD3/LP4	24	RTIP3	60	JTMS	96	RTIP7	132
D4/AD4/LP5	25	RRING3	61	JTCLK	97	RRING7	133
D5/AD5/LP6	26	TVSS4	62	JTDO	98	TVSS8	134
D6/AD6/LP7	27	TRING4	63	JTDI	99	TRING8	135
D7/AD7/BSWP/LP8	28	TTIP4	64	TCLK6	100	TTIP8	136
TCLK2	29	TVDD4	65	TPOS6/TDATA6	101	TVDD8	137
TPOS2/TDATA2	30	RRING4	66	TNEG6	102	RRING8	138
TNEG2	31	RTIP4	67	RCLK6	103	RTIP8	139
RCLK2	32	RLOS4/RXPROBEC1	68	RPOS6/RDATA6	104	RLOS8	140
RPOS2/RDATA2	33	RNEG4/CV4	69	RNEG6/CV6	105	RNEG8/CV8	141
RNEG2/CV2	34	RPOS4/RDATA4	70	RLOS6	106	RPOS8/RDATA8	142
RLOS2/RXPROBEA1	35	RCLK4	71	TCLK5	107	RCLK8	143
TCLK1	36	TNEG4	72	TPOS5/TDATA5	108	TNEG8	144

4.1 Hardware and Host Port Operation

4.1.1 Hardware Mode

The DS26303 supports a hardware configuration mode that allows the user to configure the device through setting levels on the device's pins. This mode allows the configuration of the DS26303 without the use of a microprocessor. Not all of the device features are supported in the hardware mode. To see all available options for this hardware mode, see the pin descriptions in [Table 4-1](#).

The following table provides two basic examples of configurations available in hardware mode by setting pins.

Table 4-2. Hardware Mode Configuration Examples

PIN NAME, HARDWARE MODE	STANDARD MODE CONFIGURATION		NOTES
	T1	E1	
TTIP[8:1]	Output	Output	—
TRING[8:1]	Output	Output	—
RTIP[8:1]	Input	Input	—
RRING[8:1]	Input	Input	—
TPOS[8:1]	Input	Input	—
TNEG[8:1]	Input	Input	—
TCLK[8:1]	Input: 1.544MHz	Input: 2.048MHz	—
RPOS[8:1]	Output	Output	—
RNEG[8:1]	Output	Output	—
RCLK[8:1]	Output: 1.544MHz	Output: 2.048MHz	—
MCLK	Input: 1.544MHz	Input: 2.048MHz	Used as recovery clock.
RLOS[8:1]	Output	Output	Meets T1.231 and ITU G.775.
MODESEL	0	0	Low for hardware mode.
TIMPRM	0	0 (Part number ends in -75)	100Ω for T1 mode/75Ω E1 mode.
CODE	1	1	AMI endocoding/decoding.
JAS	N.C.: Pulled to VDDIO/2	N.C.: Pulled to VDDIO/2	Jitter attenuator is not used.
TS[2:0]	111	000	Set template T1 (655ft)-100Ω/E1-75Ω.
RIMPOFF	0	0	Receive impedance should default to on.
INTB	N.C.	N.C.	Not used in hardware mode.
LP[8:1]	N.C.: Pulled to VDDIO/2	N.C.: Pulled to VDDIO/2	Internally pulled to VDDIO/2.
RIMPMS	0	0	Internal impedance mode selected.
GMC[3:0]	0000	0000	No monitoring enabled.
OE	1	1	TTIP and TRING are outputs.
CLKE	0	0	RPOSn/RNEGn are clocked on rising edge.
JTRSTB	Input, Pulled Up	Input, Pulled Up	JTAG.
JTMS	Input	Input	
JTCLK	Input	Input	
JTDO	Output, High-Z	Output, High-Z	
JTDI	Input, Pulled Up	Input, Pulled Up	
RSTB	Input, Pullup	Input, Pullup	Reset.
CLKA	N.C.	N.C.	Not available in hardware node.
scan_mode	0	0	Pull low or ground. Used only in factory test.

4.1.2 Serial Port Operation

Setting MODESEL = VDDIO/2 enables the serial bus interface on the DS26303. Port read/write timing is unrelated to the system transmit and receive timing, allowing asynchronous reads or writes by the host. See Section 10.3 for the AC timing of the serial port. All serial port accesses are LSB first when BSWP pin is low and MSB first when BSWP is high. Figure 4-3 to Figure 4-5 show operation with LSB first.

This port is compatible with the SPI interface defined for Motorola processors. An example of this is Motorola's MMC2107.

Reading or writing to the internal registers requires writing one address/command byte prior to transferring register data. The first bit written (LSB) of the address/command byte specifies whether the access is a read (1) or a write (0). The next 5 bits identify the register address (A1 to A5; A6 and A7 are ignored).

All data transfers are initiated by driving the CSB input low. When CLKE is low, SDO data is output on the rising edge of SCLK and when CLKE is high, data is output on the falling edge of SCLK. Data is held until the next falling or rising edge. All data transfers are terminated if CSB input transitions high. Port control logic is disabled and SDO is tri-stated when CSB is high. SDI is always sampled on the rising edge of SCLK.

Figure 4-3. Serial Port Operation for Write Access

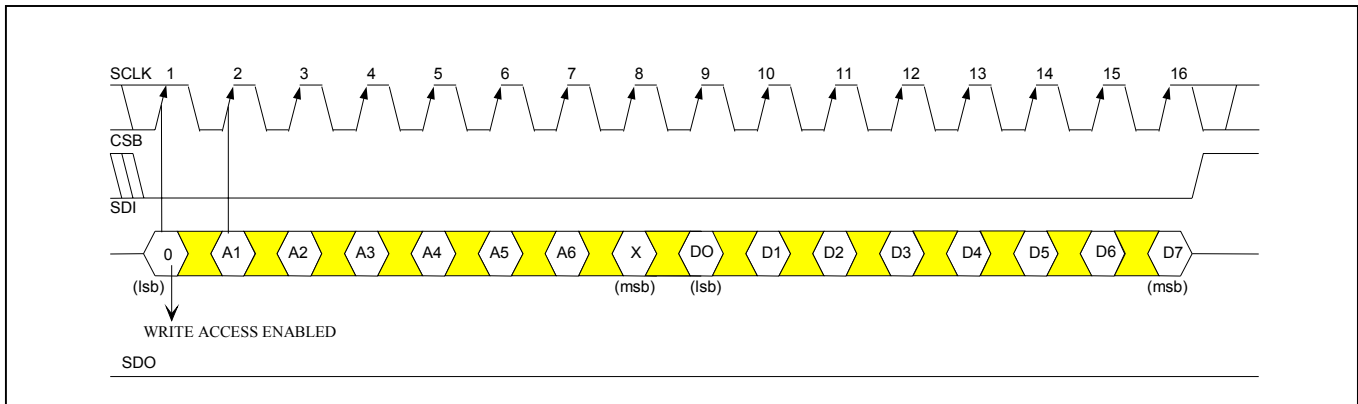

Figure 4-4. Serial Port Operation for Read Access with CLKE = 0

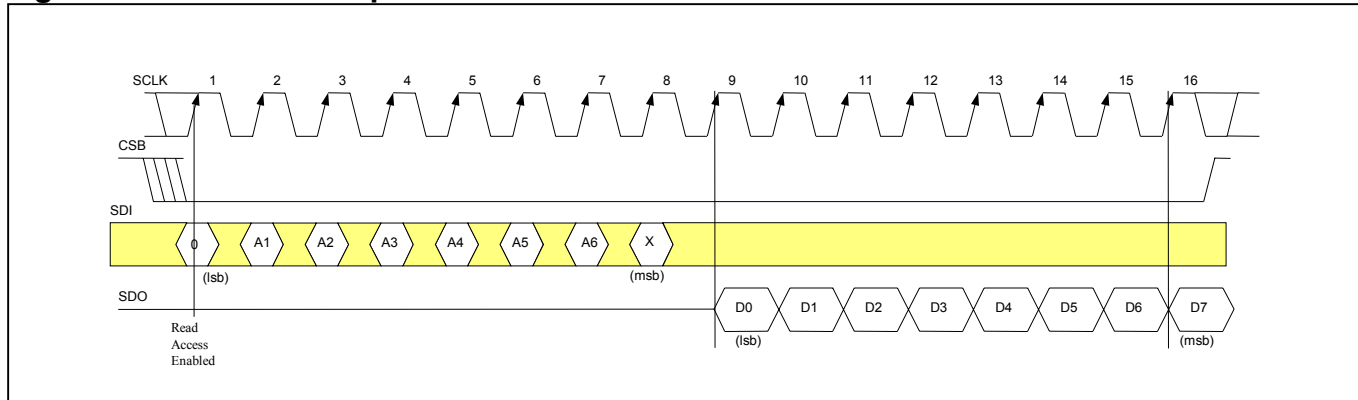
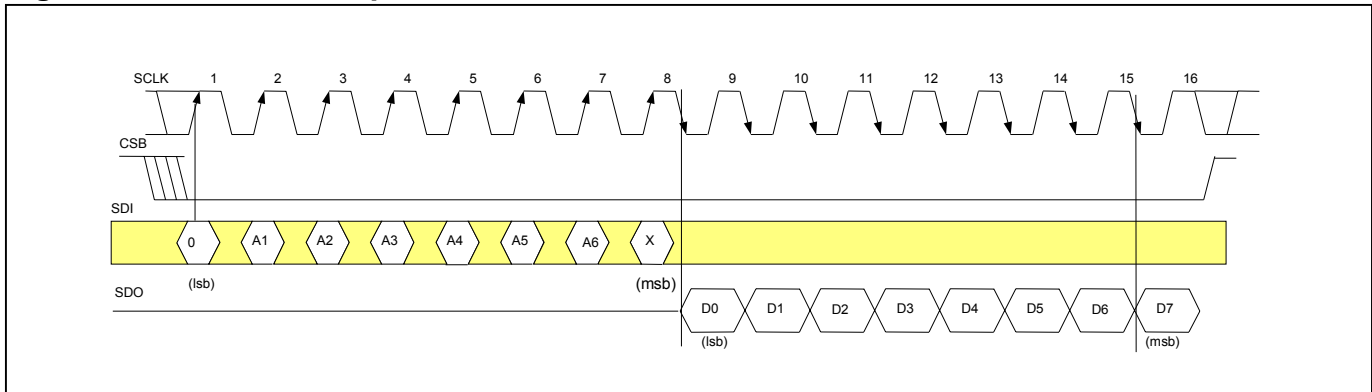

Figure 4-5. Serial Port Operation for Read Access with CLKE = 1

4.1.3 Parallel Port Operation

When using the parallel interface on the DS26303 the user has the option for either multiplexed bus operation or nonmultiplexed bus operation. The ALE pin is pulled high in nonmultiplexed bus operation. The DS26303 can operate with either Intel or Motorola bus-timing configurations selected by MOTEL pin. This pin being high selects the Intel mode. The parallel port is only operational if MODESEL pin is pulled high. The following table lists all the pins and their functions in the parallel port mode. See the timing diagrams in Section 10 for more details.

Table 4-3. Parallel Port Mode Selection and Pin Functions

MODESEL, MOTEL, MUX	PARALLEL HOST INTERFACE	ADDRESS, DATA, AND CONTROL
100	Nonmultiplexed Motorola	CSB, ACKB, DSB, RWB, ASB, A [4:0], D [7:0], $\overline{\text{INTB}}$
110	Nonmultiplexed Intel	CSB, RDY, WRB, RDB, ALE, A [4:0], D [7:0], $\overline{\text{INTB}}$
101	Multiplexed Motorola	CSB, ACKB, DSB, RWB, ASB, AD [7:0], $\overline{\text{INTB}}$
111	Multiplexed Intel	CSB, RDY, WRB, RDB, ALE, AD [7:0], $\overline{\text{INTB}}$

4.1.4 Interrupt Handling

There are four sets of events that can potentially trigger an interrupt. The interrupt functions as follows:

- When status changes on an interruptible event, the $\overline{\text{INTB}}$ pin will go low if the event is enabled through the corresponding interrupt-enable register. $\overline{\text{INTB}}$ must be pulled high externally with a 10k Ω resistor for wired-OR operation. If a wired-OR operation is not required, the $\overline{\text{INTB}}$ pin can be configured to be high when not active by setting register [GISC.INTM](#).
- When an interrupt occurs, the host processor must read the interrupt status register to determine the source of the interrupt. The read also clears the Interrupt Status register and clears the output $\overline{\text{INTB}}$ pin. The interrupt status register can also be configured as clear-on-write as per register [GISC.CWE](#). This clears $\overline{\text{INTB}}$ when a clear-on-write is performed.
- Subsequently, the host processor can read the corresponding status register to check the real-time status of the event.

Figure 4-6. Interrupt Handling Flow Diagram

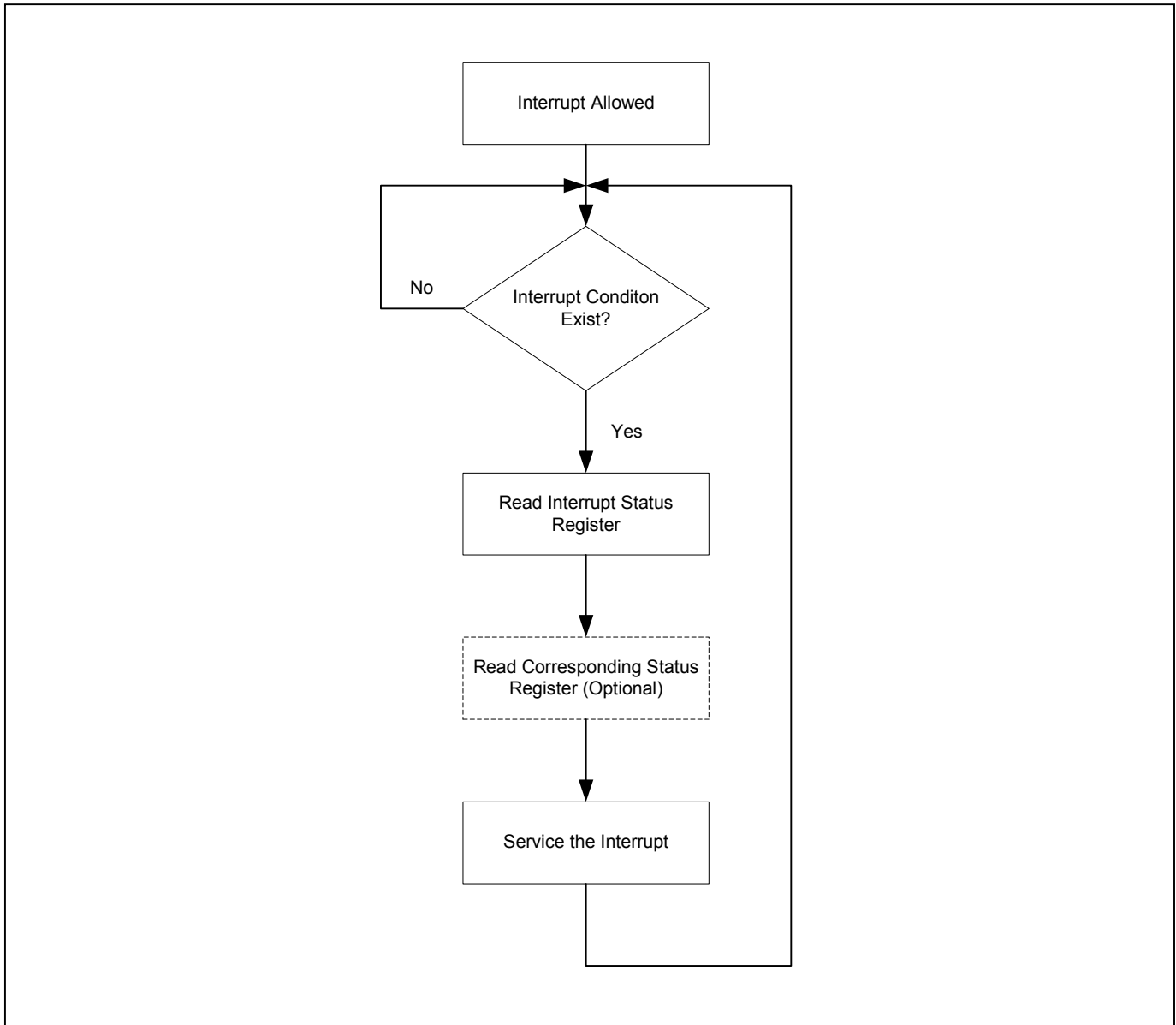

5 REGISTERS

Five address bits are used to control the settings of the registers. In the parallel nonmultiplexed mode, AD[4:0] is used. In multiplexed mode, AD[4:0] is used and AD[5:1] is used in serial mode. The register space contains control for channels 1 to 8 from address 00 hex to 1F hex. The [ADDP](#) (1F) register is used as a pointer to access the different banks of registers. This register must be set to AA hex for access of the secondary bank of registers, 01 hex for access to the individual LIU bank of registers, and 02 hex for access of the BERT bank of registers. The primary bank of registers is accessed upon reset of this register to 00 hex.

Table 5-1. Primary Register Set

NAME	SYMBOL	ADDRESS			RW
		HEX	PARALLEL INTERFACE A7–A0 (HEX)	SERIAL INTERFACE A7–A1 (HEX)	
Identification	ID	00	xxx00000	xx00000	R
Analog Loopback Configuration	ALBC	01	xxx00001	xx00001	RW
Remote Loopback Configuration	RLBC	02	xxx00010	xx00010	RW
Transmit All-Ones Enable	TAOE	03	xxx00011	xx00011	RW
LOS Status	LOSS	04	xxx00100	xx00100	R
Driver Fault Monitor Status	DFMS	05	xxx00101	xx00101	R
LOS Interrupt Enable	LOSIE	06	xxx00110	xx00110	RW
Driver Fault Monitor Interrupt Enable	DFMIE	07	xxx00111	xx00111	RW
LOS Interrupt Status	LOSI	08	xxx01000	xx01000	R
Driver Fault Monitor Interrupt Status	DFMIS	09	xxx01001	xx01001	R
Software Reset	SWR	0A	xxx01010	xx01010	W
G.772 Monitor Configuration	GMC	0B	xxx01011	xx01011	RW
Digital Loopback Configuration	DLBC	0C	xxx01100	xx01100	RW
LOS/AIS Criteria Selection	LASCS	0D	xxx01101	xx01101	RW
Automatic Transmit All-Ones Select	ATAOS	0E	xxx01110	xx01110	RW
Global Configuration	GC	0F	xxx01111	xx01111	RW
Template Select Transceiver Register	TST	10	xxx10000	xx10000	RW
Template Select	TS	11	xxx10001	xx10001	RW
Output-Enable Bar	OEB	12	xxx10010	xx10010	RW
Alarm Indication Signal	AIS	13	xxx10011	xx10011	R
AIS Interrupt Enable	AISIE	14	xxx10100	xx10100	RW
AIS Interrupt Status	AISIS	15	xxx10101	xx10101	R
Reserved	—	16–1E	xxx10110– xxx11110	xx10110– xx11110	—
Address Pointer for Secondary Register Set	ADDP	1F	xxx11111	xx11111	RW

Table 5-2. Secondary Register Set

NAME	SYMBOL	ADDRESS			RW
		HEX	PARALLEL INTERFACE A7–A0 (HEX)	SERIAL INTERFACE A7–A1 (HEX)	
Single Rail-Mode Select	SRMS	00	xxx00000	xx00000	RW
Line Code Selection	LCS	01	xxx00001	xx00001	RW
Not Used	—	02	xxx00010	xx00010	—
Receive Power-Down Enable	RPDE	03	xxx00011	xx00011	RW
Transmit Power-Down Enable	TPDE	04	xxx00100	xx00100	RW
Excessive Zero Detect Enable	EZDE	05	xxx00101	xx00101	RW
Code Violation Detect Enable Bar	CVDEB	06	xxx00110	xx00110	RW
Not Used	—	07–1E	xxx00111– xxx11110	xx00111– xx11110	—
Address Pointer for Secondary Register Set	ADDP	1F	xxx11111	xx11111	RW

Table 5-3. Individual LIU Register Set

NAME	SYMBOL	ADDRESS			RW
		HEX	PARALLEL INTERFACE A7–A0 (HEX)	SERIAL INTERFACE A7–A1 (HEX)	
Individual JA Enable	IJAE	00	xxx00000	xx00000	RW
Individual JA Position Select	IJAPS	01	xxx00001	xx00001	RW
Individual JA FIFO Depth Select	IJAFDS	02	xxx00010	xx00010	RW
Individual JA FIFO Limit Trip	IJAFLT	03	xxx00011	xx00011	R
Individual Short Circuit Protection Disable	ISCPD	04	xxx00100	xx00100	RW
Individual AIS Select	IAISEL	05	xxx00101	xx00101	RW
Master Clock Select	MC	06	xxx00110	xx00110	RW
Global Management Register	GMR	07	xxx00111	xx00111	RW
Reserved	Reserved	08–0B	xxx01000– xxx01011	xx01000– xx01011	RW
Reserved	Reserved	0C–0F	xxx01100– xxx01111	xx01100– xx01111	R
Bit Error Rate Tester Control Register	BTCR	10	xxx10000	xx10000	RW
Line Violation Detect Status	LVDS	12	xxx10010	xx10010	R
Receive Clock Invert	RCLKI	13	xxx10011	xx10011	RW
Transmit Clock Invert	TCLKI	14	xxx10100	xx10100	RW
Clock Control Register	CCR	15	xxx10101	xx10101	RW
RCLK Disable Upon LOS Register	RDULR	16	xxx10110	xx10110	RW
Global Interrupt Status Control	GISC	1E	xxx11110	xx11110	RW
Address Pointer for Secondary Register Set	ADDP	1F	xxx11111	xx11111	RW

Table 5-4. BERT Register Set

NAME	SYMBOL	ADDRESS			RW
		HEX	PARALLEL INTERFACE A7–A0 (HEX)	SERIAL INTERFACE A7–A1 (HEX)	
BERT Control Register	BCR	00	xxx00000	xx00000	RW
Reserved	—	01	xxx00001	xx00001	
BERT Pattern Configuration 1	BPCR1	02	xxx00010	xx00010	RW
BERT Pattern Configuration 2	BPCR2	03	xxx00011	xx00011	RW
BERT Seed/Pattern 1	BSPR1	04	xxx00100	xx00100	RW
BERT Seed/Pattern 2	BSPR2	05	xxx00101	xx00101	RW
BERT Seed/Pattern 3	BSPR3	06	xxx00110	xx00110	RW
BERT Seed/Pattern 4	BSPR4	07	xxx00111	xx00111	RW
Transmit Error Insertion Control	TEICR	08	xxx01000	xx01000	RW
Reserved	—	09–0A	xxx01001– xx01010	—	—
BERT Status Register	BSR	0C	xxx01100	xx01100	R
Reserved		0D	xxx01101	xx01101	
BERT Status Register Latched	BSRL	0E	xxx10011	xx10011	RW
BERT Status Register Interrupt Enable	BSRIE	10	xxx10000	xx10000	RW
Reserved	—	11–13	xxx10001– xxx10011	xx10001– xx10011	—
Receive Bit Error Count Register 1	RBECCR1	14	xxx10100	xx10100	R
Receive Bit Error Count Register 2	RBECCR2	15	xxx10101	xx10101	R
Receive Bit Error Count Register 3	RBECCR3	16	xxx10110	xx10110	R
Receive Bit Error Count Register 4	RBECCR4	17	xxx10111	xx10111	R
Receive Bit Count Register 1	RBCR1	18	xxx11000	xx11000	R
Receive Bit Count Register 2	RBCR2	19	xxx11001	xx11001	R
Receive Bit Count Register 3	RBCR3	1A	xxx11010	xx11010	R
Receive Bit Count Register 4	RBCR4	1B	xxx11011	xx11011	R
Reserved	—	1C–1E	xxx11100– xxx11110	xx11100– xx11110	—
Address Pointer for Secondary Register Set	ADDP	1F	xxx11111	xx11111	RW

Table 5-5. Primary Register Set Bit Map

REGISTER	ADDRESS	TYPE	BIT 7	BIT 6	BIT 5	BIT 4	BIT 3	BIT 2	BIT 1	BIT 0
ID	00	R	ID7	ID6	ID5	ID4	ID3	ID2	ID1	ID0
ALBC	01	RW	ALC8	ALBC7	ALBC6	ALBC5	ALBC4	ALBC3	ALBC2	ALBC1
RLBC	02	RW	RLBC8	RLBC7	RLBC6	RLBC5	RLBC4	RLBC3	RLBC2	RLBC1
TAOE	03	RW	TAOE8	TAOE7	TAOE6	TAOE5	TAOE4	TAOE3	TAOE2	TAOE1
LOSS	04	RW	LOSS8	LOSS7	LOSS6	LOSS5	LOSS4	LOSS3	LOSS2	LOSS1
DFMS	05	RW	DFMS8	DFMS7	DFMS6	DFMS5	DFMS4	DFMS3	DFMS2	DFMS1
LOSIE	06	RW	LOSIE8	LOSIE7	LOSIE6	LOSIE5	LOSIE4	LOSIE3	LOSIE2	LOSIE1
DFMIE	07	RW	DFMIE8	DFMIE7	DFMIE6	DFMIE5	DFMIE4	DFMIE3	DFMIE2	DFMIE1
LOSIS	08	R	LOSIS8	LOSIS7	LOSIS6	LOSIS5	LOSIS4	LOSIS3	LOSIS2	LOSIS1
DFMIS	09	R	DFMIS8	DFMIS7	DFMIS6	DFMIS5	DFMIS4	DFMIS3	DFMIS2	DFMIS1
SWR	0A	W	SWR8	SWR7	SWR6	SWR5	SWR4	SWR3	SWR2	SWR1
GMC	0B	RW	—	—	—	—	GMC4	GMC3	GMC2	GMC1
DLBC	0C	RW	DLBC8	DLBC7	DLBC6	DLBC5	DLBC4	DLBC3	DLBC2	DLBC1
LASCS	0D	RW	LASCS8	LASCS7	LASCS6	LASCS5	LASCS4	LASCS3	LASCS2	LASCS1
ATAOS	0E	RW	ATAOS8	ATAOS7	ATAOS6	ATAOS5	ATAOS4	ATAOS3	ATAOS2	ATAOS1
GC	0F	RW	RIMPMS	AISEL	SCPD	CODE	JADS	—	JAPS	JAE
TST	10	RW	—	—	—	—	—	TST2	TST1	TST0
TS	11	RW	RIMPOFF	TIMPOFF	T1MODE	TIMPRM1	TIMPRM	TS2	TS1	TS0
OEB	12	RW	OEB8	OEB7	OEB6	OEB5	OEB4	OEB3	OEB2	OEB1
AIS	13	R	AIS8	AIS7	AIS6	AIS5	AIS4	AIS3	AIS2	AIS1
AISIE	14	RW	AISIE8	AISIE7	AISIE6	AISIE5	AISIE4	AISIE3	AISIE2	AISIE1
AISI	15	R	AISI8	AISI7	AISI6	AISI5	AISI4	AISI3	AISI2	AISI1
Not Used	16-1E	—	—	—	—	—	—	—	—	—
ADDP	1F	RW	ADDP7	ADDP6	ADDP5	ADDP4	ADDP3	ADDP2	ADDP1	ADDP0

Table 5-6. Secondary Register Set Bit Map

REGISTER	ADDRESS	TYPE	BIT 7	BIT 6	BIT 5	BIT 4	BIT 3	BIT 2	BIT 1	BIT 0
SRS	00	RW	SRMS8	SRMS7	SRMS6	SRMS5	SRMS4	SRMS3	SRMS2	SRMS1
LCS	01	RW	LCS8	LCS7	LCS6	LCS5	LCS4	LCS3	LCS2	LCS1
Not Used	02	RW	—	—	—	—	—	—	—	—
RPDE	03	RW	RPDE8	RPDE7	RPDE6	RPDE5	RPDE4	RPDE3	RPDE2	RPDE1
TPDE	04	RW	TPDE8	TPDE7	TPDE6	TPDE5	TPDE4	TPDE3	TPDE2	TPDE1
EZDE	05	RW	EZDE8	EZDE7	EZDE6	EZDE5	EZDE4	EZDE3	EZDE2	EZDE1
CVDEB	06	RW	CVDEB8	CVDEB7	CVDEB6	CVDEB5	CVDEB4	CVDEB3	CVDEB2	CVDEB1
Not Used	07-1E	—	—	—	—	—	—	—	—	—
ADDP	1F	RW	ADDP7	ADDP6	ADDP5	ADDP4	ADDP3	ADDP2	ADDP1	ADDP0

Table 5-7. Individual LIU Register Set Bit Map

REGISTER	ADDRESS	TYPE	BIT 7	BIT 6	BIT 5	BIT 4	BIT 3	BIT 2	BIT 1	BIT 0
IJAE	00	RW	IJAE8	IJAE7	IJAE6	IJAE5	IJAE4	IJAE3	IJAE2	IJAE1
IJAPS	01	RW	IJAPS8	IJAPS7	IJAPS6	IJAPS5	IJAPS4	IJAPS3	IJAPS2	IJAPS1
IJAFDS	02	RW	IJAFDS8	IJAFDS7	IJAFDS6	IJAFDS5	IJAFDS4	IJAFDS3	IJAFDS2	IJAFDS1
IJAFLT	03	R	IJAFLT8	IJAFLT7	IJAFLT6	IJAFLT5	IJAFLT4	IJAFLT3	IJAFLT2	IJAFLT1
ISCPD	04	RW	ISCPD8	ISCPD7	ISCPD6	ISCPD5	ISCPD4	ISCPD3	ISCPD2	ISCPD1
IAISEL	05	RW	IAISEL8	IAISEL7	IAISEL6	IAISEL5	IAISEL4	IAISEL3	IAISEL2	IAISEL1
MC	06	RW	—	PCLKI	TECLKE	CLKAE	MPS1	MPS0	FREQS	PLLE
GMR	07	RW	—	—	—	—	—	—	—	RHPMC
Reserved	08	RW	—	—	—	—	—	—	—	—
Reserved	09	RW	—	—	—	—	—	—	—	—
Reserved	0A	RW	—	—	—	—	—	—	—	—
Reserved	0B	RW	—	—	—	—	—	—	—	—
Reserved	0C	R	—	—	—	—	—	—	—	—
Reserved	0D	R	—	—	—	—	—	—	—	—
Reserved	0E	R	—	—	—	—	—	—	—	—
Reserved	0F	R	—	—	—	—	—	—	—	—
BTCR	10	RW	BTS2	BTS1	BTS0	—	—	—	—	BERTE
BEIR	11	RW	BEIR8	BEIR7	BEIR6	BEIR5	BEIR4	BEIR3	BEIR2	BEIR1
LVDS	12	R	LVDS8	LVDS7	LVDS6	LVDS5	LVDS4	LVDS3	LVDS2	LVDS1
RCLKI	13	RW	RCLKI8	RCLKI7	RCLKI6	RCLKI5	RCLKI4	RCLKI3	RCLKI2	RCLKI1
TCLKI	14	RW	TCLKI8	TCLKI7	TCLKI6	TCLKI5	TCLKI4	TCLKI3	TCLKI2	TCLKI1
CCR	15	RW	PCLKS2	PCLKS1	PCLKS0	TECLKS	CLKA3	CLKA2	CLKA1	CLKA0
RDULR	16	RW	RDULR8	RDULR7	RDULR6	RDULR5	RDULR4	RDULR3	RDULR2	RDULR1
GISC	1E	RW	—	—	—	—	—	—	INTM	CWE
ADDP	1F	RW	ADDP7	ADDP6	ADDP5	ADDP4	ADDP3	ADDP2	ADDP1	ADDP0

Table 5-8. BERT Register Bit Map

REGISTER	ADDRESS	TYPE	BIT 7	BIT 6	BIT 5	BIT 4	BIT 3	BIT 2	BIT 1	BIT 0
BCR	00	RW	PMUM	LPMU	RNPL	RPIC	MPR	APRD	TNPL	TPIC
Not Used	01	—	—	—	—	—	—	—	—	—
BPCR1	02	RW	—	QRSS	PTS	PLF4	PLF3	PLF2	PLF1	PLF0
BPCR2	03	—	—	—	—	PTF4	PTF3	PTF2	PTF1	PTF0
BSPR1	04	RW	BSP7	BSP6	BSP5	BSP4	BSP3	BSP2	BSP1	BSP0
BSPR2	05	—	BSP15	BSP14	BSP13	BSP12	BSP11	BSP10	BSP9	BSP8
BSPR3	06	RW	BSP23	BSP22	BSP21	BSP20	BSP19	BSP18	BSP17	BSP16
BSPR4	07	—	BSP31	BSP30	BSP29	BSP28	BSP27	BSP26	BSP25	BSP24
TEICR	08	RW	—	—	TEIR2	TEIR1	TEIR0	BEI	TSEI	MEIMS
Not Used	09–0B	—	—	—	—	—	—	—	—	—
BSR	0C	R/W	—	—	—	—	PMS	—	<u>BEC</u>	<u>OOS</u>
Not Used	0D	—	—	—	—	—	—	—	—	—
BSRL	0E	RL/W	—	—	—	—	PMSL	<u>BEL</u>	<u>BEC</u> <u>L</u>	<u>OOS</u> <u>L</u>
Not Used	0F	—	—	—	—	—	—	—	—	—
BSRIE	10	RW	—	—	—	—	PMSIE	BEIE	BECIE	OOSIE
Not Used	11–13	—	—	—	—	—	—	—	—	—
RBECR1	14	R	<u>BEC</u> 7	<u>BEC</u> 6	<u>BEC</u> 5	<u>BEC</u> 4	<u>BEC</u> 3	<u>BEC</u> 2	<u>BEC</u> 1	<u>BEC</u> 0
RBECR2	15	R	<u>BEC</u> 15	<u>BEC</u> 14	<u>BEC</u> 13	<u>BEC</u> 12	<u>BEC</u> 11	<u>BEC</u> 10	<u>BEC</u> 9	<u>BEC</u> 8
RBECR3	16	R	<u>BEC</u> 23	<u>BEC</u> 22	<u>BEC</u> 21	<u>BEC</u> 20	<u>BEC</u> 19	<u>BEC</u> 18	<u>BEC</u> 17	<u>BEC</u> 16
Not Used	17	—	—	—	—	—	—	—	—	—
RBCR1	18	R	<u>BC</u> 7	<u>BC</u> 6	<u>BC</u> 5	<u>BC</u> 4	<u>BC</u> 3	<u>BC</u> 2	<u>BC</u> 1	<u>BC</u> 0
RBCR2	19	R	<u>BC</u> 15	<u>BC</u> 14	<u>BC</u> 13	<u>BC</u> 12	<u>BC</u> 11	<u>BC</u> 10	<u>BC</u> 9	<u>BC</u> 8
RBCR3	1A	R	<u>BC</u> 23	<u>BC</u> 22	<u>BC</u> 21	<u>BC</u> 20	<u>BC</u> 19	<u>BC</u> 18	<u>BC</u> 17	<u>BC</u> 16
RBCR4	1B	R	<u>BC</u> 31	<u>BC</u> 30	<u>BC</u> 29	<u>BC</u> 28	<u>BC</u> 27	<u>BC</u> 26	<u>BC</u> 25	<u>BC</u> 24
Not Used	1C–1E	—	—	—	—	—	—	—	—	—
ADDP	1F	RW	ADDP7	ADDP6	ADDP5	ADDP4	ADDP3	ADDP2	ADDP1	ADDP0

Note: Underlined bits are read-only.

5.1 Register Description

This section details the register description of each bit. Whenever the variable '*n*' in italics is used in any of the register descriptions, it represents 1, 2, 3, 4, 5, 6, 7, and 8.

5.1.1 Primary Registers

Register Name: **ID**
 Register Description: **ID Register**
 Register Address: **00h**

Bit #	7	6	5	4	3	2	1	0
Name	<u>ID7</u>	<u>ID6</u>	<u>ID5</u>	<u>ID4</u>	<u>ID3</u>	<u>ID2</u>	<u>ID1</u>	<u>ID0</u>

Bit 7: Device CODE ID Bit 7 (ID7). This bit is zero for the 75Ω impedance part number and one for the 120Ω impedance part number.

Bits 6 to 3: Device CODE ID Bits 6 to 3 (ID6 to ID3). These bits tell the user the number of ports the device contains.

Bits 2 to 0: Device CODE ID Bits 2 to 0 (ID2 to ID0). These bits tell the user the revision of the part. Contact the factory for details.

Register Name: **ALBC**
 Register Description: **Analog Loopback Control**
 Register Address: **01h**

Bit #	7	6	5	4	3	2	1	0
Name	ALBC8	ALBC7	ALBC6	ALBC5	ALBC4	ALBC3	ALBC2	ALBC1
Default	0	0	0	0	0	0	0	0

Bits 7 to 0: Analog Loopback Control Bits Channel *n* (ALBC_{*n*}). When this bit is set, LIU_{*n*} is placed in analog loopback. TTIP and TRING are looped back to RTIP and RRING. The data at RTIP and RRING is ignored. LOS detector is still in operation. The jitter attenuator is in use if enabled for the transmitter or receiver.

Register Name: **RLBC**
 Register Description: **Remote Loopback Control**
 Register Address: **02h**

Bit #	7	6	5	4	3	2	1	0
Name	RLBC8	RLBC7	RLBC6	RLBC5	RLBC4	RLBC3	RLBC2	RLBC1
Default	0	0	0	0	0	0	0	0

Bits 7 to 0: Remote Loopback Control Bits Channel *n* (RLBC_{*n*}). When this bit is set, remote loopback is enabled on LIU_{*n*}. The analog-received signal goes through the receive digital and is looped back to the transmitter. The data at TPOS and TNEG is ignored. The jitter attenuator is in use if enabled.

Register Name: **TAOE**
 Register Description: **Transmit All-Ones Enable**
 Register Address: **03h**

Bit #	7	6	5	4	3	2	1	0
Name	TAOE8	TAOE7	TAOE6	TAOE5	TAOE4	TAOE3	TAOE2	TAOE1
Default	0	0	0	0	0	0	0	0

Bits 7 to 0: Transmit All-Ones Enable Channel n (TAOE n). When this bit is set, a continuous stream of all ones on TTIP and TRING are sent on channel n . MCLK is used as a reference clock for the transmit all-ones signal. The data arriving at TPOS and TNEG is ignored.

Register Name: **LOSS**
 Register Description: **Loss-of-Signal Status**
 Register Address: **04h**

Bit #	7	6	5	4	3	2	1	0
Name	LOS8	LOS7	LOS6	LOS5	LOS4	LOS3	LOS2	LOS1
Default	0	0	0	0	0	0	0	0

Bits 7 to 0: Loss-of-Signal Status Channel n (LOS n). When this bit is set, an LOS condition has been detected on LIUn. The criteria and conditions of LOS are described in Section [6.4.3: Loss of Signal](#).

Register Name: **DFMS**
 Register Description: **Driver Fault Monitor Status**
 Register Address: **05h**

Bit #	7	6	5	4	3	2	1	0
Name	DFMS8	DFMS7	DFMS6	DFMS5	DFMS4	DFMS3	DFMS2	DFMS1
Default	0	0	0	0	0	0	0	0

Bits 7 to 0: Driver Fault Monitor Status Channel n (DFMS n). When this bit is set, it indicates that there is a short circuit at the transmit driver for LIUn.

Register Name: **LOSIE**
 Register Description: **Loss-of-Signal Interrupt Enable**
 Register Address: **06h**

Bit #	7	6	5	4	3	2	1	0
Name	LOSIE8	LOSIE7	LOSIE6	LOSIE5	LOSIE4	LOSIE3	LOSIE2	LOSIE1
Default	0	0	0	0	0	0	0	0

Bits 7 to 0: Loss-of-Signal Interrupt Enable Channel n (LOSIE n). When this bit is set, a change in the LOS status for LIUn can generate an interrupt.

Register Name: **DFMIE**
 Register Description: **Driver Fault Monitor Interrupt Enable**
 Register Address: **07h**

Bit #	7	6	5	4	3	2	1	0
Name	DFMIE8	DFMIE7	DFMIE6	DFMIE5	DFMIE4	DFMIE3	DFMIE2	DFMIE1
Default	0	0	0	0	0	0	0	0

Bits 7 to 0: Driver Fault Monitor Interrupt Enable Channel n (DFMIE n). When this bit is set, a change in DFM status can generate an interrupt in monitor n .

Register Name: **LOSI8**
 Register Description: **Loss-of-Signal Interrupt Status**
 Register Address: **08h**

Bit #	7	6	5	4	3	2	1	0
Name	LOSI8	LOSI7	LOSI6	LOSI5	LOSI4	LOSI3	LOSI2	LOSI1
Default	0	0	0	0	0	0	0	0

Bits 7 to 0: Loss-of-Signal Interrupt Status Channel n (LOSI n). When this bit is set, it indicates an LOS status has transitioned from a 0 to 1 or 1 to 0 and was detected for LIU n . The bit for LIU n is enabled by register LOSIE(06h). This bit when latched is cleared on a read operation.

Register Name: **DFMIS**
 Register Description: **Driver Fault Monitor Interrupt Status**
 Register Address: **09h**

Bit #	7	6	5	4	3	2	1	0
Name	DFMIS8	DFMIS7	DFMIS6	DFMIS5	DFMIS4	DFMIS3	DFMIS2	DFMIS1
Default	0	0	0	0	0	0	0	0

Bits 7 to 0: Driver Fault Status Register Channel n (DFMIS n). When this bit is set, it indicates a DFM status has transitioned from “0 to 1” or “1 to 0” and was detected for LIU n . The bit for LIU n is enabled by register DFMIE(07h). This bit when latched is cleared on a read operation.

Register Name: **SWR**
 Register Description: **Software Reset**
 Register Address: **0Ah**

Bit #	7	6	5	4	3	2	1	0
Name	SWR8	SWR7	SWR6	SWR5	SWR4	SWR3	SWR2	SWR1
Default	0	0	0	0	0	0	0	0

Bits 7 to 0: Software Reset (SWR). Whenever any write is performed to this register, at least a 1 μ s reset will be generated that resets the DS26303. All the registers will be restored to their default values. A read operation will always read back all zeros.

Register Name: **GMC**
 Register Description: **G.772 Monitoring Control**
 Register Address: **0Bh**

Bit #	7	6	5	4	3	2	1	0
Name	—	—	—	—	GMC3	GMC2	GMC1	GMC0
Default	0	0	0	0	0	0	0	0

Bits 3 to 0: G.772 Monitoring Control (GMC). These bits are used to select transmitter or receiver for nonintrusive monitoring. Receiver 1 is used to monitor channels 2 to 8 of one receiver from RTIP2–RTIP8/RRING2–RRING8 or of one transmitter from TTIP2–TTIP8/TRING2–TRING8. See [Table 5-9](#).

Table 5-9. G.772 Monitoring Control

GMC3	GMC2	GMC1	GMC0	SELECTION
0	0	0	0	No Monitoring
0	0	0	1	Receiver 2
0	0	1	0	Receiver 3
0	0	1	1	Receiver 4
0	1	0	0	Receiver 5
0	1	0	1	Receiver 6
0	1	1	0	Receiver 7
0	1	1	1	Receiver 8
1	0	0	0	No Monitoring
1	0	0	1	Transmitter 2
1	0	1	0	Transmitter 3
1	0	1	1	Transmitter 4
1	1	0	0	Transmitter 5
1	1	0	1	Transmitter 6
1	1	1	0	Transmitter 7
1	1	1	1	Transmitter 8

Register Name: **DLBC**
 Register Description: **Digital Loopback Control**
 Register Address: **0Ch**

Bit #	7	6	5	4	3	2	1	0
Name	DLBC8	DLBC7	DLBC6	DLBC5	DLBC4	DLBC3	DLBC2	DLBC1
Default	0	0	0	0	0	0	0	0

Bits 7 to 0: Digital Loopback Control Channel *n* (DLBC_{*n*}). When this bit is set, the LIU_{*n*} is placed in digital loopback. The data at TPOS/TNEG is encoded and looped back to the decoder and output on RPOS/RNEG. The jitter attenuator can optionally be included in the transmit or receive paths.

Register Name: **LASCS**
 Register Description: **LOS/AIS Criteria Selection**
 Register Address: **0Dh**

Bit #	7	6	5	4	3	2	1	0
Name	LASCS8	LASCS7	LASCS6	LASCS5	LASCS4	LASCS3	LASCS2	LASCS1
Default	0	0	0	0	0	0	0	0

Bits 7 to 0: LOS/AIS Criteria Selection Channel *n* (LASCS_{*n*}). This bit is used for LOS/AIS selection criteria for LIU_{*n*}. In E1 mode if set, these bits use ETSI (300233) mode selections. If reset, these bits use G.775 criteria. In T1/J1 mode, T1.231 criteria is selected.

Register Name: **ATAOS**
 Register Description: **Automatic Transmit All-Ones Select**
 Register Address: **0Eh**

Bit #	7	6	5	4	3	2	1	0
Name	ATAOS8	ATAOS7	ATAOS6	ATAOS5	ATAOS4	ATAOS3	ATAOS2	ATAOS1
Default	0	0	0	0	0	0	0	0

Bit 7 to 0: Automatic Transmit All-Ones Select Channel *n* (ATAOS n). When this bit is set an all-ones signal is sent if a loss of signal is detected for LIU n . All-ones signal uses MCLK as the reference clock.

Register Name: **GC**
 Register Description: **Global Configuration**
 Register Address: **0Fh**

Bit #	7	6	5	4	3	2	1	0
Name	RIMPMS	AISEL	SCPD	CODE	JADS	—	JAPS	JAE
Default	0	0	0	0	0	0	0	0

Bit 7: Receive Impedance Mode Select (RIMPMS). When this bit is set, the internal impedance mode is selected, so RTIP and RING require no external resistance component. When this mode is selected, the die attach pad on the bottom of the package should be connected to ground for thermal dissipation. When reset, external impedance mode is selected so RTIP and RING require external resistance. Note that when in external impedance mode, the resistance is still adjusted internally for the T1 (100 Ω), J1 (110 Ω), and E1(75 Ω) modes of operation by the template selected so that only one resistor value is required externally. In E1 (120 Ω), external impedance mode has no need for any internal adjustment.

Bit 6: AIS Enable During Loss (AISEL). When this bit is set, an AIS is sent to the system side upon detecting an LOS for each channel. The individual LIU register [IAISEL](#) settings are ignored when this bit is set. When reset, the [IAISEL](#) register has control.

Bit 5: Short-Circuit-Protection Disable (SCPD). If this bit is set, the short-circuit protection is disabled for all the transmitters. The individual LIU register [ISCPD](#) settings are ignored when this bit is set. When reset, the [ISCPD](#) register has control.

Bit 4: Code (CODE). If this bit is set, AMI encoder/decoder is selected. The [LCS](#) register settings are ignored when this bit is set. If reset, the [LCS](#) register has control.

Bit 3: Jitter Attenuator Depth Select (JADS). If this bit is set the jitter attenuator FIFO depth is 128 bits. The settings in the [IJAFDS](#) register are ignored if this register is set. If reset, the [IJAFDS](#) register has control.

Bit 1: Jitter Attenuator Position Select (JAPS). When the JAPS bit is set high, the JA is in the receive path, and when it is default or set low, it is in the transmit path. These settings can be changed for an individual LIU by settings in register [IJAPS](#). Note that when bit JAE is set, the settings in register [IJAPS](#) are ignored.

Bit 0: Jitter Attenuator Enable (JAE). When this bit is set the JA is enabled. The settings in the [IJAE](#) register are ignored if this register is set. If reset, the IJAE register has control.

Register Name: **TST**
 Register Description: **Template Select Transmitter Register**
 Register Address: **10h**

Bit #	7	6	5	4	3	2	1	0
Name	—	—	—	—	—	TST2	TST1	TST0
Default	0	0	0	0	0	0	0	0

Bits 2 to 0: TST Template Select Transceiver [2:0] (TST [2:0]). TST[2:0] is used to select the transceiver that the transmit template select register (hex 11) applies to. See [Table 5-10](#).

Table 5-10. TST Template Select Transmitter Register

TST[2:0]	CHANNEL	TST[2:0]	CHANNEL
000	1	100	5
001	2	101	6
010	3	110	7
011	4	111	8

Register Name: **TS**
 Register Description: **Template Select Register**
 Register Address: **11h**

Bit #	7	6	5	4	3	2	1	0
Name	RIMPOFF	TIMPOFF	—	—	TIMPRM	TS2	TS1	TS0
Default	0	0	—	—	0	0	0	0

Bit 7: Receive Impedance Match Off (RIMPOFF). If this bit is set, all the receive impedance match is turned off.

Bit 6: Transmit Impedance Termination Off (TIMPOFF). If this bit is set, all the internal transmit terminating impedance is turned off.

Bits 5 and 4: Reserved

Bit 3: Transmit Impedance Receive Match (TIMPRM). This bit selects the internal transmit termination impedance and receive impedance match for E1 mode and T1/J1 mode. Note: If the part number ends with –120, then the default is 120Ω and 75Ω when set for E1 mode only.

DEVICE	BIT SETTING	E1 MODE (Ω)	T1 MODE (Ω)
DS26303L-120	0	120	100
DS26303L-120	1	75	110
DS26303L-75	0	75	100
DS26303L-75	1	120	110

Bits 2 to 0: Template Selection [2:0] (TS[2:0]). Bits TS[2:0] are used to select E1 or T1/J1 mode, the template, and the settings for various cable lengths. The impedance termination for the transmitter and impedance match for the receiver are specified by bit TIMPRM. See [Table 5-11](#) for bit selection of TS[2:0].

Table 5-11. Template Selection

TS[2:0]	LINE LENGTH	CABLE LOSS (dB)	IMPEDANCE (Ω) ¹	OPERATION MODE
011	0–133ft. ABAM	0.6	100/110	T1/J1
100	133–266ft. ABAM	1.2	100/110	T1
101	266–399ft. ABAM	1.8	100/110	T1
110	399–533ft. ABAM	2.4	100/110	T1
111	533–655ft. ABAM	3.0	100/110	T1
000	G.703 coaxial and twisted pair cable		75/120	E1
001 and 010	Reserved		—	—

¹See *TIMPRM* bit in *SWM* or *TIMPRM* pin in *HWM* for transmit impedance and receive match selection.

Register Name: **OEB**
Register Description: **Output-Enable Bar**
Register Address: **12h**

Bit #	7	6	5	4	3	2	1	0
Name	OEB8	OEB7	OEB6	OEB5	OEB4	OEB3	OEB2	OEB1
Default	0	0	0	0	0	0	0	0

Bits 7 to 0: Output-Enable Bar Channel n (OEB n). When this bit is set the transmitter output for LIU n is placed in high impedance. Note that the OE pin overrides this setting when low.

Register Name: **AIS**
Register Description: **Alarm Indication Signal Status**
Register Address: **13h**

Bit #	7	6	5	4	3	2	1	0
Name	AIS8	AIS7	AIS6	AIS5	AIS4	AIS3	AIS2	AIS1
Default	0	0	0	0	0	0	0	0

Bits 7 to 0: Alarm Indication Signal Channel n (AIS n). This bit is set when AIS is detected for LIU n . The criteria for AIS selection is detailed in Section [6.4.4: AIS](#). The selection of the AIS criteria is done by settings in [LASCS](#) (0D) register.

Register Name: **AISIE**
 Register Description: **AIS Interrupt Enable**
 Register Address: **14h**

Bit #	7	6	5	4	3	2	1	0
Name	AISIE8	AISIE7	AISIE6	AISIE5	AISIE4	AISIE3	AISIE2	AISIE1
Default	0	0	0	0	0	0	0	0

Bits 7 to 0: AIS Interrupt Mask Channel n (AISIE n). When this bit is set, interrupts can be generated for LIU n if AIS status transitions.

Register Name: **AISI**
 Register Description: **AIS Interrupt**
 Register Address: **15h**

Bit #	7	6	5	4	3	2	1	0
Name	AISI8	AISI7	AISI6	AISI5	AISI4	AISI3	AISI2	AISI1
Default	0	0	0	0	0	0	0	0

Bits 7 to 0: AIS Interrupt Channel n (AISIn). This bit is set when AIS transitions from a 0 to 1 or 1 to 0 and interrupts are enabled by the [AISIE](#)(14) register for LIU n . This bit if set is cleared on a read operation or when the interrupt-enable register is disabled.

Register Name: **ADDP**
 Register Description: **Address Pointer**
 Register Address: **1Fh**

Bit #	7	6	5	4	3	2	1	0
Name	ADDP7	ADDP6	ADDP5	ADDP4	ADDP3	ADDP2	ADDP1	ADDP0
Default	0	0	0	0	0	0	0	0

Bits 7 to 0: Address Pointer (ADDP). This pointer is used to switch between pointing to the primary registers, the secondary registers, individual registers, BERT registers, and all the test registers. See [Table 5-12](#) for bank selection.

Table 5-12. Address Pointer Bank Selection

ADDP7 TO ADDP0 (HEX)	BANK NAME
00	Primary Bank
AA	Secondary Bank
01	Individual LIU Bank
02	BERT Bank
03	Global Test Bank
04	LIU1 Test Bank
05	LIU2 Test Bank
06	LIU3 Test Bank
07	LIU4 Test Bank
08	LIU5 Test Bank
09	LIU6 Test Bank
0A	LIU7 Test Bank
0B	LIU8 Test Bank

5.1.2 Secondary Registers

Register Name: **SRMS**
 Register Description: **Single-Rail Mode Select**
 Register Address: **00h**

Bit #	7	6	5	4	3	2	1	0
Name	SRMS8	SRMS7	SRMS6	SRMS5	SRMS4	SRMS3	SRMS2	SRMS1
Default	0	0	0	0	0	0	0	0

Bits 7 to 0: Single-Rail Mode Select Channel n (SRMS n). When this bit is set, single-rail mode is selected for the system transmit and receive n . If this bit is reset, dual-rail mode is selected.

Register Name: **LCS**
 Register Description: **Line Code Selection**
 Register Address: **01h**

Bit #	7	6	5	4	3	2	1	0
Name	LCS8	LCS7	LCS6	LCS5	LCS4	LCS3	LCS2	LCS1
Default	0	0	0	0	0	0	0	0

Bits 7 to 0: Line Code Select Channel n (LCS n). When this bit is set, AMI encoding/decoding is selected for LIU n . If reset B8ZS or HDB3 encoding/decoding is selected for LIU n . Note that if the [GC.CODE](#) (0F) register is set it will ignore this register.

Register Name: **RPDE**
 Register Description: **Receive Power-Down Enable**
 Register Address: **03h**

Bit #	7	6	5	4	3	2	1	0
Name	RPDE8	RPDE7	RPDE6	RPDE5	RPDE4	RPDE3	RPDE2	RPDE1
Default	0	0	0	0	0	0	0	0

Bits 7 to 0: Receive Power-Down Enable Channel n (RPDE n). When this bit is set, the receiver for LIU n is powered down.

Register Name: **TPDE**
 Register Description: **Transmit Power-Down Enable**
 Register Address: **04h**

Bit #	7	6	5	4	3	2	1	0
Name	TPDE7	TPDE6	TPDE5	TPDE4	TPDE3	TPDE2	TPDE1	TPDE0
Default	0	0	0	0	0	0	0	0

Bits 7 to 0: Transmit Power-Down Enable Channel n (TPDE n). When this bit is set, the transmitter for LIU n is powered down.

Register Name: **EZDE**
 Register Description: **Excessive Zero Detect Enable**
 Register Address: **05h**

Bit #	7	6	5	4	3	2	1	0
Name	EXZDE8	EXZDE7	EXZDE6	EXZDE5	EXZDE4	EXZDE3	EXZDE2	EXZDE1
Default	0	0	0	0	0	0	0	0

Bits 7 to 0: Excessive Zero Detect Enable Channel n (EZDE n). When this bit is reset, excessive zero detection is disabled for LIU n . When this bit is set, excessive zero detect enable is enabled. Excessive zero detection is only relevant in single-rail mode with HDB3 or B8ZS encoding.

Register Name: **CVDEB**
 Register Description: **Code Violation Detect Enable Bar**
 Register Address: **06h**

Bit #	7	6	5	4	3	2	1	0
Name	CVDEB8	CVDEB7	CVDEB6	CVDEB5	CVDEB4	CVDEB3	CVDEB2	CVDEB1
Default	0	0	0	0	0	0	0	0

Bits 7 to 0: Code Violation Detect Enable Bar Channel n (CVDEB n). If this bit is set, code violation detection is disabled for the LIU n . If this bit is reset, code violation detection is enabled. Code violation detection is only relevant in single-rail mode with HDB3 encoding. Note that if the [GC.CODE](#) register bit is set, it ignored the settings of this register.

5.1.3 Individual LIU Registers

Register Name: **IJAE**
 Register Description: **Individual Jitter Attenuator Enable**
 Register Address: **00h**

Bit #	7	6	5	4	3	2	1	0
Name	IJAE8	IJAE7	IJAE6	IJAE5	IJAE4	IJAE3	IJAE2	IJAE1
Default	0	0	0	0	0	0	0	0

Bits 7 to 0: Individual Jitter Attenuator Enable Channel n (IJAE n). When this bit is set, the LIU jitter attenuator n is enabled. Note that if the [GC.JAE](#) register bit is set, this register is ignored.

Register Name: **IJAPS**
 Register Description: **Individual Jitter Attenuator Position Select**
 Register Address: **01h**

Bit #	7	6	5	4	3	2	1	0
Name	IJAPS8	IJAPS7	IJAPS6	IJAPS5	IJAPS4	IJAPS3	IJAPS2	IJAPS1
Default	0	0	0	0	0	0	0	0

Bits 7 to 0: Individual Jitter Attenuator Position Select Channel n (IJAPS n). When this bit is set high, the jitter attenuator is in the receive path n , and when this bit is default or set low the jitter attenuator is in the transmit path n . Note that if the [GC.JAE](#) register bit is set, this register is ignored.

Register Name: **IJAFDS**
 Register Description: **Individual Jitter Attenuator FIFO Depth Select**
 Register Address: **02h**

Bit #	7	6	5	4	3	2	1	0
Name	IJAFDS8	IJAFDS7	IJAFDS6	IJAFDS5	IJAFDS4	IJAFDS3	IJAFDS2	IJAFDS1
Default	0	0	0	0	0	0	0	0

Bits 7 to 0: Individual Jitter Attenuator FIFO Depth Select n (IJAFDS n). When this bit is set for LIUn, the jitter attenuator FIFO depth is 128 bits. When reset, the jitter attenuator FIFO depth is 32 bits. Note that if the [GC.IJAFDS](#) register is set, this register is ignored.

Register Name: **IJAFLT**
 Register Description: **Individual Jitter Attenuator FIFO Limit Trip**
 Register Address: **03h**

Bit #	7	6	5	4	3	2	1	0
Name	IJAFLT8	IJAFLT7	IJAFLT6	IJAFLT5	IJAFLT4	IJAFLT3	IJAFLT2	IJAFLT1
Default	0	0	0	0	0	0	0	0

Bits 7 to 0: Individual Jitter Attenuator FIFO Limit Trip n (IJAFLT n). Set when the jitter attenuator FIFO reaches to within 4 bits of its useful limit for transmitter n . This bit is cleared when read.

Register Name: **ISCPD**
 Register Description: **Individual Short-Circuit Protection Disabled**
 Register Address: **04h**

Bit #	7	6	5	4	3	2	1	0
Name	ISCPD8	ISCPD7	ISCPD6	ISCPD5	ISCPD4	ISCPD3	ISCPD2	ISCPD1
Default	0	0	0	0	0	0	0	0

Bits 7 to 0: Individual Short-Circuit Protection Disabled n (ISCPD n). When this bit is set, the short-circuit protection is disabled for the individual transmitter n . Note that if the [GC.SCPD](#) register bit is set, the settings in this register are ignored.

Register Name: **IAISEL**
 Register Description: **Individual AIS Select**
 Register Address: **05h**

Bit #	7	6	5	4	3	2	1	0
Name	IAISEL8	IAISEL7	IAISEL6	IAISEL5	IAISEL4	IAISEL3	IAISEL2	IAISEL1
Default	0	0	0	0	0	0	0	0

Bits 7 to 0: Individual AIS Enable During Loss n (IAISEL n). When this bit is set, individual-AIS-enable during loss is enabled for the individual receiver n and AIS is sent to the system side upon detection of an LOS. Note that if the [GC.AISEL](#) register bit is set, the settings in this register are ignored.

Register Name: **MC**
 Register Description: **Master Clock Select**
 Register Address: **06h**

Bit #	7	6	5	4	3	2	1	0
Name	—	PCLKI	TECLKE	CLKAE	MPS1	MPS0	FREQS	PLLE
Default	0	0	0	0	0	0	0	0

Bit 6: PLL Clock Input (PCLKI). This bit selects the input into to the PLL.

0 = MCLK is used.

1 = RCLK1–RCLK8 is used based on the selection in register [CCR](#).

Bit 5: T1/E1 Clock Enable (TECLKE). When this bit is set the TECLK output is enabled. If not set TECLK is disabled and the TECLK output is an RLOS output. TECLK requires PLLE to be set for correct functionality.

Bit 4: Clock A Enable (CLKAE). When this bit is set the CLKA output is enabled. If not set CLKA is disabled to tri-state. CLKA requires PLLE to be set for correct functionality.

Bits 3 to 2: Master Period Select [1:0] (MPS[1:0]). These bits MPS[1:0] selects the external MCLK frequency for the DS26303. See [Table 5-13](#) for details.

Bit 1: Frequency Select (FREQS). In conjunction with MPS[1:0], this bit selects the external MCLK frequency for the DS26303. If this bit is set the external master clock can be 1.544MHz or a multiple thereof. If not set the external master clock can be 2.048MHz or a multiple thereof. See [Table 5-13](#) for details.

Bit 0: Phase Lock Loop Enable (PLLE). When this bit is set the phase lock loop is enabled. If not set MCLK is the applied input clock.

Table 5-13. MCLK Selections

PLLE	MPS1, MPS0	MCLK (MHz/±50ppm)	FREQS	MODE
0	xx	1.544	x	T1
0	xx	2.048	x	E1
1	00	1.544	1	T1/J1 or E1
1	01	3.088	1	T1/J1 or E1
1	10	6.176	1	T1/J1 or E1
1	11	12.352	1	T1/J1 or E1
1	00	2.048	0	T1/J1 or E1
1	01	4.096	0	T1/J1 or E1
1	10	8.192	0	T1/J1 or E1
1	11	16.384	0	T1/J1 or E1

Register Name: **GMR**
 Register Description: **Global Management Register**
 Register Address: **07h**

Bit #	7	6	5	4	3	2	1	0
Name	—	—	—	—	—	—	—	RHPMC
Default	0	0	0	0	0	0	0	0

Bit 0: Receive Hitless-Protection Mode Control (RHPMC). This bit when set and, when the OE pin goes low, will force all the receivers to turn off any internal impedance matching on RTIP and RRING. This is used for hitless-protection switching when the user would like a system requiring no external relays in the system.

Register Name: **BTCR**
 Register Description: **Bit Error-Rate Tester Control Register**
 Register Address: **10h**

Bit #	7	6	5	4	3	2	1	0
Name	BTS2	BTS1	BTS0	—	—	—	—	BERTE
Default	0	0	0	0	0	0	0	0

Bits 7 to 5: Bit Error-Rate Transceiver Select [2:0] (BTS[2:0]). These bits BTS[2:0] select the LIU that the BERT applies to. This is only applicable if the BERTE bit is set.

Bit 0: Bit Error-Rate Tester Enable (BERTE). When this bit is set, the BERT is enabled. The BERT is only active for one transceiver at a time selected by BTS[2:0].

Register Name: **BEIR**
 Register Description: **BPV Error Insertion Register**
 Register Address: **11h**

Bit #	7	6	5	4	3	2	1	0
Name	BEIR8	BEIR7	BEIR6	BEIR5	BEIR4	BEIR3	BEIR2	BEIR1
Default	0	0	0	0	0	0	0	0

Bits 7 to 0: BPV Error Insertion Register n (BEIR n). A 0-to-1 transition on this bit causes a single bipolar violation (BPV) to be inserted into the transmit data stream channel n . This bit must be cleared and set again for a subsequent error to be inserted.

Register Name: **LVDS**
 Register Description: **Line Violation Detect Status**
 Register Address: **12h**

Bit #	7	6	5	4	3	2	1	0
Name	<u>LVDS8</u>	<u>LVDS7</u>	<u>LVDS6</u>	<u>LVDS5</u>	<u>LVDS4</u>	<u>LVDS3</u>	<u>LVDS2</u>	<u>LVDS1</u>
Default	0	0	0	0	0	0	0	0

Bits 7 to 0: Line Violation Detect Status n (LVDS n). A bipolar violation, code violation, or excessive zeros cause the associated LVDS n bit to latch. This bit is cleared on a read operation. The LVDS register captures the first violation within a three-clock-period window. If a second violation occurs after the first violation within the three-clock-period window, then the second violation will not be latched even if a read to the LVDS register was performed. Excessive zeros need to be enabled by the [EZDE](#) register for detection by this register. Code violations are only relative when in HDB3 mode and can be disabled for detection by this register by setting the [CVDEB](#) register. In dual-rail mode only bipolar violations are relevant for this register.

Register Name: **RCLKI**
 Register Description: **Receive Clock Invert**
 Register Address: **13h**

Bit #	7	6	5	4	3	2	1	0
Name	RCLKI8	RCLKI7	RCLKI6	RCLKI5	RCLKI4	RCLKI3	RCLKI2	RCLKI1
Default	0	0	0	0	0	0	0	0

Bits 7 to 0: Receive Clock Invert n (RCLKI n). When this bit is set the RCLK for channel n is inverted. This aligns RPOS/RNEG on the falling edge of RCLK. When reset or default, RPOS/RNEG is aligned on the rising edge of RCLK. Note that if the CLKE pin is high, the RPOS/RNEG is set on the falling edge of RCLK regardless of the settings in the register.

Register Name: **TCLKI**
 Register Description: **Transmit Clock Invert**
 Register Address: **14h**

Bit #	7	6	5	4	3	2	1	0
Name	TCLKI8	TCLKI7	TCLKI6	TCLKI5	TCLKI4	TCLKI3	TCLKI2	TCLKI1
Default	0	0	0	0	0	0	0	0

Bits 7 to 0: Transmit Clock Invert n (TCLKI n). When this bit is set the expected TCLK for channel n is inverted. TPOS/TNEG should be aligned on the rising edge of TCLK. When reset or default TPOS/TNEG should be aligned on the falling edge of TCLK.

Register Name: **CCR**
 Register Description: **Clock Control Register**
 Register Address: **15h**

Bit #	7	6	5	4	3	2	1	0
Name	PCLKS2	PCLKS1	PCLKS0	TECLKS	CLKA3	CLKA2	CLKA1	CLKA0
Default	0	0	0	0	0	0	0	0

Bits 7 to 5: PLL Clock Select (PCLKS[2:0]). These bits determine the RCLK that is to be used as the input to the PLL. If an LOS is detected for the channel that RCLK is recovered from, the PLL switches to MCLK until the LOS is cleared. When the LOS is cleared, RCLK is used again. See [Table 5-14](#) for RCLK selection.

Table 5-14. PLL Clock Select

PCLKS2 TO PCLKS0	PLL CLOCK SELECTED MC.PCLKI = 1
000	RCLK1
001	RCLK2
010	RCLK3
011	RCLK4
100	RCLK5
101	RCLK6
110	RCLK7
111	RCLK8

Bit 4: T1/E1 Clock Select (TECLKS). When this bit is set the T1/E1 clock output is 2.048MHz. When this bit is reset the T1/E1 clock rate is 1.544MHz.

Bits 3 to 0: Clock A Select (CLKA[3:0]). These bits select the output frequency for CLKA pin. See [Table 5-15](#) for available frequencies.

Table 5-15. Clock A Select

CLKA3 TO CLKA0	MCLK (Hz)
0000	2.048M
0001	4.096M
0010	8.192M
0011	16.384M
0100	1.544M
0101	3.088M
0110	6.176M
0111	12.352M
1000	1.536M
1001	3.072M
1010	6.144M
1011	12.288M
1100	32k
1101	64k
1110	128k
1111	256k

Register Name: **RDULR**
 Register Description: **RCLK Disable Upon LOS Register**
 Register Address: **16h**

Bit #	7	6	5	4	3	2	1	0
Name	RDULR8	RDULR7	RDULR6	RDULR5	RDULR4	RDULR3	RDULR2	RDULR1
Default	0	0	0	0	0	0	0	0

Bits 7 to 0: RCLK Disable Upon LOS Register n (RDULR n). When this bit is set the RCLK for channel n is disabled upon a loss of signal and set as a low output. When reset or default, RCLK switches to MCLK upon a loss of signal within 10ms.

Register Name: **GISC**
 Register Description: **Global Interrupt Status Control**
 Register Address: **1Eh**

Bit #	7	6	5	4	3	2	1	0
Name	—	—	—	—	—	—	INTM	CWE
Default	0	0	0	0	0	0	0	0

Bit 1: INT Pin Mode (INTM). This bit determines the inactive mode of the $\overline{\text{INT}}$ pin. The $\overline{\text{INT}}$ pin always drives low when active.

0 = Pin is high impedance when not active.

1 = Pin drives high when not active.

Bit 0: Clear-On-Write Enable (CWE). When this bit is set, the clear-on-write is enabled for all the latched interrupt status registers. The host processor must write a 1 to the latched interrupt status register bit position before the particular bit is cleared. Default for all the latched interrupt status registers is to clear on a read.

5.1.4 BERT Registers

Register Name: **BCR**
 Register Description: **BERT Control Register**
 Register Address: **00h**

Bit #	7	6	5	4	3	2	1	0
Name	PMUM	LPMU	RNPL	RPIC	MPR	APRD	TNPL	TPIC
Default	0	0	0	0	0	0	0	0

Bit 7: Performance-Monitoring Update Mode (PMUM). When 0, a performance-monitoring update is initiated by the LPMU register bit. When 1, a performance-monitoring update is initiated by the receive performance-monitoring update signal (RPMU). Note: If RPMU or LPMU is 1, changing the state of this bit may cause a performance-monitoring update to occur.

Bit 6: Local Performance-Monitoring Update (LPMU). This bit causes a performance-monitoring update to be initiated if the local performance-monitoring update is enabled (PMUM = 0). A 0-to-1 transition causes the performance-monitoring registers to be updated with the latest data, and the counters reset (0 or 1). For a second performance-monitoring update to be initiated, this bit must be set to 0, and back to 1. If LPMU goes low before the PMS bit goes high, an update might not be performed. This bit has no affect when PMUM = 1.

Bit 5: Receive New Pattern Load (RNPL). A 0-to-1 transition of this bit causes the programmed test pattern (QRSS, PTS, PLF[4:0], PTF[4:0], and BSP[31:0]) to be loaded in to the receive pattern generator. This bit must be changed to 0 and back to 1 for another pattern to be loaded. Loading a new pattern forces the receive pattern generator out of the sync state, which causes a resynchronization to be initiated. Note: QRSS, PTS, PLF[4:0], PTF[4:0], and BSP[31:0] must not change from the time this bit transitions from 0 to 1 until four RXCK clock cycles after this bit transitions from 0 to 1.

Bit 4: Receive Pattern Inversion Control (RPIC). When 0, the receive incoming data stream is not altered. When 1, the receive incoming data stream is inverted.

Bit 3: Manual Pattern Resynchronization (MPR). A 0-to-1 transition of this bit causes the receive pattern generator to resynchronize to the incoming pattern. This bit must be changed to 0 and back to 1 for another resynchronization to be initiated. Note: A manual resynchronization forces the receive pattern generator out of the sync state.

Bit 2: Automatic Pattern Resynchronization Disable (APRD). When 0, the receive pattern generator automatically resynchronizes to the incoming pattern if six or more times during the current 64-bit window the incoming data stream bit and the receive pattern generator output bit did not match. When 1, the receive pattern generator does not automatically resynchronize to the incoming pattern. Note: Automatic synchronization is prevented by not allowing the receive pattern generator to automatically exit the sync state.

Bit 1: Transmit New Pattern Load (TNPL). A 0-to-1 transition of this bit causes the programmed test pattern (QRSS, PTS, PLF[4:0], PTF[4:0], and BSP[31:0]) to be loaded in to the transmit pattern generator. This bit must be changed to zero and back to one for another pattern to be loaded. Note: QRSS, PTS, PLF[4:0], PTF[4:0], and BSP[31:0] must not change from the time this bit transitions from 0 to 1 until four TXCK clock cycles after this bit transitions from 0 to 1.

Bit 0: Transmit Pattern Inversion Control (TPIC). When 0, the transmit outgoing data stream is not altered. When 1, the transmit outgoing data stream is inverted.

Register Name: **BPCR1**
 Register Description: **BERT Pattern Configuration Register 1**
 Register Address: **02h**

Bit #	7	6	5	4	3	2	1	0
Name	—	QRSS	PTS	PLF4	PLF3	PLF2	PLF1	PLF0
Default	0	0	0	0	0	0	0	0

Bit 6: QRSS Enable (QRSS). When 0, the pattern generator configuration is controlled by PTS, PLF[4:0], and PTF[4:0], and BSP[31:0]. When 1, the pattern generator configuration is forced to a PRBS pattern with a generating polynomial of $x^{20} + x^{17} + 1$. The output of the pattern generator is forced to one if the next 14 output bits are all 0.

Bit 5: Pattern Type Select (PTS). When 0, the pattern is a PRBS pattern. When 1, the pattern is a repetitive pattern.

Bits 4 to 0: Pattern Length Feedback (PLF[4:0]). These bits control the “length” feedback of the pattern generator. The length feedback is from bit n of the pattern generator ($n = \text{PLF}[4:0] + 1$). For a PRBS signal, the feedback is an XOR of bit n and bit y . For a repetitive pattern the feedback is bit n .

Register Name: **BPCR 2**
 Register Description: **BERT Pattern Configuration Register 2**
 Register Address: **03h**

Bit #	7	6	5	4	3	2	1	0
Name	—	—	—	PTF4	PTF3	PTF2	PTF1	PTF0
Default	0	0	0	0	0	0	0	0

Bits 4 to 0: Pattern Tap Feedback (PTF[4:0]). These bits control the PRBS “tap” feedback of the pattern generator. The tap feedback is from bit y of the pattern generator ($y = \text{PTF}[4:0] + 1$). These bits are ignored when programmed for a repetitive pattern. For a PRBS signal, the feedback is an XOR of bit n and bit y .

Register Name: **BSPR1**
 Register Description: **BERT Seed/Pattern Register #1**
 Register Address: **04h**

Bit #	7	6	5	4	3	2	1	0
Name	BSP7	BSP6	BSP5	BSP4	BSP3	BSP2	BSP1	BSP0
Default	0	0	0	0	0	0	0	0

Register Name: **BSPR2**
 Register Description: **BERT Seed/Pattern Register #2**
 Register Address: **05h**

Bit #	7	6	5	4	3	2	1	0
Name	BSP15	BSP14	BSP13	BSP12	BSP11	BSP10	BSP9	BSP8
Default	0	0	0	0	0	0	0	0

Register Name: **BSPR3**
 Register Description: **BERT Seed/Pattern Register #3**
 Register Address: **06h**

Bit #	7	6	5	4	3	2	1	0
Name	BSP23	BSP22	BSP21	BSP20	BSP19	BSP18	BSP17	BSP16
Default	0	0	0	0	0	0	0	0

Register Name: **BSPR4**
 Register Description: **BERT Seed/Pattern Register #4**
 Register Address: **07h**

Bit #	7	6	5	4	3	2	1	0
Name	BSP31	BSP30	BSP29	BSP28	BSP27	BSP26	BSP25	BSP24
Default	0	0	0	0	0	0	0	0

Bits 31 to 0: BERT Seed/Pattern (BSP[31:0]). These 32 bits are the programmable seed for a transmit PRBS pattern, or the programmable pattern for a transmit or receive repetitive pattern. BSP(31) is the first bit output on the transmit side for a 32-bit repetitive pattern or 32-bit length PRBS. BSP(31) is the first bit input on the receive side for a 32-bit repetitive pattern.

Register Name: **TEICR**
 Register Description: **Transmit Error-Insertion Control Register**
 Register Address: **08h**

Bit #	7	6	5	4	3	2	1	0
Name	—	—	TEIR2	TEIR1	TEIR0	BEI	TSEI	MEIMS
Default	0	0	0	0	0	0	0	0

Bits 5 to 3: Transmit Error-Insertion Rate (TEIR[2:0]). These bits indicate the rate at which errors are inserted in the output data stream. One out of every 10^n bits is inverted. TEIR[2:0] is the value n. A TEIR[2:0] value of 0 disables error insertion at a specific rate. A TEIR[2:0] value of 1 result in every 10th bit being inverted. A TEIR[2:0] value of 2 result in every 100th bit being inverted. Error insertion starts when this register is written to with a TEIR[2:0] value that is non-zero. If this register is written to during the middle of an error insertion process, the new error rate will be started after the next error is inserted.

Bit 2: Bit-Error-Insertion Enable (BEI). When 0, single bit-error insertion is disabled. When 1, single bit-error insertion is enabled.

Bit 1: Transmit Single Error Insert (TSEI). This bit causes a bit error to be inserted in the transmit data stream if manual error insertion is disabled (MEIMS = 0) and single bit-error insertion is enabled. A 0-to-1 transition causes a single bit error to be inserted. For a second bit error to be inserted, this bit must be set to 0, and back to 1. Note: If MEIMS is low, and this bit transitions more than once between error insertion opportunities, only one error is inserted.

Bit 0: Manual-Error Insert-Mode Select (MEIMS). When 0, error insertion is initiated by the TSEI register bit. When 1, error insertion is initiated by the transmit manual-error-insertion signal (TMEI). Note: If TMEI or TSEI is 1, changing the state of this bit may cause a bit error to be inserted.

Register Name: **BSR**
 Register Description: **BERT Status Register**
 Register Address: **0Ch**

Bit #	7	6	5	4	3	2	1	0
Name	—	—	—	—	PMS	—	BEC	OOS
Default	0	0	0	0	0	0	0	0

Bit 3: Performance-Monitoring Update Status (PMS). This bit indicates the status of the receive performance-monitoring register (counters) update. This bit transitions from low to high when the update is completed. PMS is asynchronously forced low when the LPMU bit (PMUM = 0) or RPMU signal (PMUM = 1) goes low.

Bit 1: Bit Error Count (BEC). When 0, the bit error count is 0. When 1, the bit error count is 1 or more.

Bit 0: Out of Synchronization (OOS). When 0, the receive pattern generator is synchronized to the incoming pattern. When 1, the receive pattern generator is not synchronized to the incoming pattern.

Register Name: **BSRL**
 Register Description: **BERT Status Register Latched**
 Register Address: **0Eh**

Bit #	7	6	5	4	3	2	1	0
Name	—	—	—	—	<u>PMSL</u>	<u>BEL</u>	<u>BECL</u>	<u>OOSL</u>
Default	0	0	0	0	0	0	0	0

Bit 3: Performance-Monitoring Update Status Latched (PMSL). This bit is set when the PMS bit transitions from 0 to 1. A read operation clears this bit.

Bit 2: Bit Error Latched (BEL). This bit is set when a bit error is detected. A read operation clears this bit.

Bit 1: Bit-Error Count Latched (BECL). This bit is set when the BEC bit transitions from 0 to 1. A read operation clears this bit.

Bit 0: Out-of-Synchronization Latched (OOSL). This bit is set when the OOS bit changes state. A read operation clears this bit.

Register Name: **BSRIE**
 Register Description: **BERT Status Register Interrupt Enable**
 Register Address: **10h**

Bit #	7	6	5	4	3	2	1	0
Name	—	—	—	—	PMSIE	BEIE	BECIE	OOSIE
Default	0	0	0	0	0	0	0	0

Bit 3: Performance-Monitoring Update Status-Interrupt Enable (PMSIE). This bit enables an interrupt if the PMSL bit is set.

0 = interrupt disabled
 1 = interrupt enabled

Bit 2: Bit-Error-Interrupt Enable (BEIE). This bit enables an interrupt if the BEL bit is set.

0 = interrupt disabled
 1 = interrupt enabled

Bit 1: Bit-Error-Count Interrupt Enable (BECIE). This bit enables an interrupt if the BECL bit is set.

0 = interrupt disabled
 1 = interrupt enabled

Bit 0: Out-of-Synchronization Interrupt Enable (OOSIE). This bit enables an interrupt if the OOSL bit is set.

0 = interrupt disabled
 1 = interrupt enabled

Register Name: **RBECR1**
 Register Description: **Receive Bit-Error-Count Register #1**
 Register Address: **14h**

Bit #	7	6	5	4	3	2	1	0
Name	<u>BEC7</u>	<u>BEC6</u>	<u>BEC5</u>	<u>BEC4</u>	<u>BEC3</u>	<u>BEC2</u>	<u>BEC1</u>	<u>BEC0</u>
Default	0	0	0	0	0	0	0	0

Register Name: **RBECR2**
 Register Description: **Receive Bit-Error-Count Register #1**
 Register Address: **15h**

Bit #	7	6	5	4	3	2	1	0
Name	<u>BEC15</u>	<u>BEC14</u>	<u>BEC13</u>	<u>BEC12</u>	<u>BEC11</u>	<u>BEC10</u>	<u>BEC9</u>	<u>BEC8</u>
Default	0	0	0	0	0	0	0	0

Register Name: **RBECR3**
 Register Description: **Receive Bit-Error-Count Register #2**
 Register Address: **16h**

Bit #	7	6	5	4	3	2	1	0
Name	<u>BEC23</u>	<u>BEC22</u>	<u>BEC21</u>	<u>BEC20</u>	<u>BEC19</u>	<u>BEC18</u>	<u>BEC17</u>	<u>BEC16</u>
Default	0	0	0	0	0	0	0	0

Bits 23 to 1: Bit Error Count (BEC[23:0]). These 24 bits indicate the number of bit errors detected in the incoming data stream. This count stops incrementing when it reaches a count of FF FFFFh. The associated bit-error counter is not incremented when an OOS condition exists.

Register Name: **RBCR1**
 Register Description: **Receive Bit Count Register #1**
 Register Address: **18h**

Bit #	7	6	5	4	3	2	1	0
Name	<u>BC7</u>	<u>BC6</u>	<u>BC5</u>	<u>BC4</u>	<u>BC3</u>	<u>BC2</u>	<u>BC1</u>	<u>BC0</u>
Default	0	0	0	0	0	0	0	0

Register Name: **RBCR2**
 Register Description: **Receive Bit Count Register #2**
 Register Address: **19h**

Bit #	15	14	13	12	11	10	9	8
Name	<u>BC15</u>	<u>BC14</u>	<u>BC13</u>	<u>BC12</u>	<u>BC11</u>	<u>BC10</u>	<u>BC9</u>	<u>BC8</u>
Default	0	0	0	0	0	0	0	0

Register Name: **RBCR3**
 Register Description: **Receive Bit Count Register #3**
 Register Address: **1Ah**

Bit #	7	6	5	4	3	2	1	0
Name	<u>BC23</u>	<u>BC22</u>	<u>BC21</u>	<u>BC20</u>	<u>BC19</u>	<u>BC18</u>	<u>BC17</u>	<u>BC16</u>
Default	0	0	0	0	0	0	0	0

Register Name: **RBCR4**
 Register Description: **Receive Bit Count Register #4**
 Register Address: **1Bh**

Bit #	15	14	13	12	11	10	9	8
Name	<u>BC31</u>	<u>BC30</u>	<u>BC29</u>	<u>BC28</u>	<u>BC27</u>	<u>BC26</u>	<u>BC25</u>	<u>BC24</u>
Default	0	0	0	0	0	0	0	0

Bits 31 to 0: Bit Count (BC[31:0]). These 32 bits indicate the number of bits in the incoming data stream. This count stops incrementing when it reaches a count of FFFF FFFFh. The associated bit counter is not incremented when an OOS condition exists.

6 FUNCTIONAL DESCRIPTION

6.1 Power-Up and Reset

Internal Power_On_Reset circuitry generates a reset during power-up. All registers are reset to the default values. Writing to the software-reset register generates at least 1 μ s reset cycle, which has the same effect as the power-up reset. A reset can also be performed in software by writing to [SWR](#) register.

6.2 Master Clock

The DS26303 requires 2.048MHz \pm 50ppm or 1.544MHz \pm 50ppm or multiple thereof. The receiver uses the MCLK as a reference for clock recovery, jitter attenuation, and generating RCLK during LOS. The AIS transmission uses MCLK for transmit all-ones condition. See register [MC](#) to set desired incoming frequency. If the PLLE bit is not set, MCLK is whatever the incoming frequency is.

MCLK or RCLK can also be used to output CLKA. Register [CCR](#) is used to select the clock generated for CLKA and the TECLK. Any RCLK can also be selected as an input to the clock generator using this same register. For a detailed description of selections available, see [Figure 6-1](#).

Figure 6-1. Pre-Scaler PLL and Clock Generator

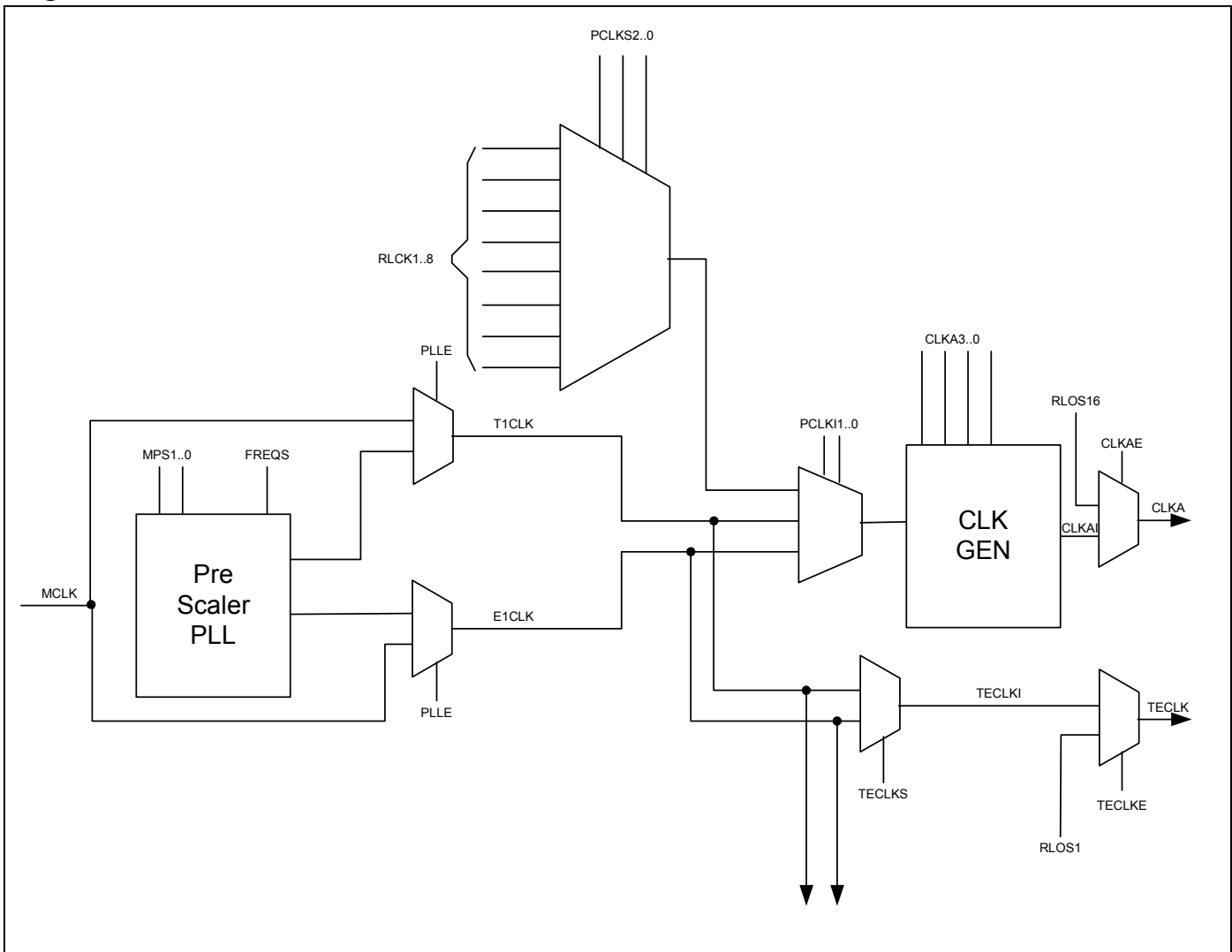

6.3 Transmitter

NRZ data arrives on TPOS and TNEG on the transmit system side. The TPOS and TNEG data is sampled on the falling edge of TCLK ([Figure 10-12](#)).

The data is encoded with HDB3 or B8ZS or NRZ encoding when single-rail mode is selected (only TPOS as the data source). When in single-rail mode only, BPV errors can be inserted for test purposes by register [BEIR](#). Preencoded data is expected when dual-rail mode is selected. The encoded data passes through a jitter attenuator if it is enabled for the transmit path. A digital sequencer and DAC generate transmit waveforms compliant with T1.102 and G.703 pulse masks.

A line driver drives an internal matched-impedance circuit for provision of 100Ω, 110Ω, 120Ω, and 75Ω termination.

The DS26303 drivers have short-circuit driver-fail-monitor detection. There is an OE pin that can high-Z the transmitter outputs for protection switching. The individual transmitters can be placed in high impedance by register [OEB](#). The DS26303 also has functionality for powering down the transmitters individually. The registers that control the transmitter operation are shown in [Table 6-3](#).

Table 6-1. Telecommunications Specification Compliance for DS26303 Transmitters

TRANSMITTER FUNCTION	TELECOMMUNICATIONS COMPLIANCE
AMI Coding, B8ZS Substitution, DS1 Electrical Interface	ANSI T1.102
T1 Telecom Pulse Mask Compliance	ANSI T1.403
T1 Telecom Pulse Mask Compliance	ANSI T1.102
Transmit Electrical Characteristics for E1 Transmission and Return Loss Compliance	ITU G.703

Table 6-2. Registers Related to Control of DS26303 Transmitters

REGISTER NAME	ACRONYM	FUNCTION
Transmit All-Ones Enable	TAOE	Transmit All-Ones Enable.
Driver Fault Monitor Status	DFMS	Driver Fault Status.
Driver Fault Monitor Interrupt Enable	DFMIE	Driver Fault Status Interrupt Mask.
Driver Fault Monitor Interrupt Status	DFMIS	Driver Fault Status Interrupt Mask.
Global Configuration Register	GC	Selection of the jitter attenuator in the transmit receive or not used and code for B8ZS or HDB3 substitution.
Template Select Transmitter	TST	The transmitter that the template select applies to.
Template Select	TS	The TS2 to TS0 bits for selection of the templates for transmitter and match impedance for the receiver.
Output Enable Configuration Register	OEB	This bits can be used to place the transmitter outputs in high-impedance mode.
Master Clock Selection	MC	Selects the MCLK frequency used for transmit and receive.
Single-Rail Mode Select Register	SRMS	This register can be used to select between single-rail and dual-rail mode.
Line Code Selection	LCS	The individual LIU line codes can be selected to overwrite the global setting.
Transmit Power-Down	TPDE	Individual transmitters can be powered down.
Individual Short-Circuit-Protection Disable	ISCPD	This register allows the individual transmitters short-circuit protection disable.
BERT Control Register	BTCR	This register is used for sending different BERT patterns for the individual transmitters.

6.3.1 Transmit Line Templates

The DS26303 the transmitters can be selected individually to meet the pulse masks for E1 and T1/J1 mode. The T1/J1 pulse mask is shown in the transmit pulse template and can be configured on an individual LIU basis. The TIMPRM pin/bit is used to select the internal transmit terminating impedance of 100Ω/110Ω for T1/J1 mode or 75Ω/120Ω for E1 mode. The T1 pulse mask is shown in [Figure 6-2](#) and the E1 pulse template is shown in [Figure 6-3](#).

Table 6-3. DS26303 Template Selections

TS2, TS1, TS0	APPLICATION
000	E1
001	Reserved
010	
011	DSX-1 (0-133 ft)
100	DSX-1 (133-266 ft)
101	DSX-1 (266-399 ft)
110	DSX-1 (399-533 ft)
111	DSX-1 (533-655 ft)

Figure 6-2. T1 Transmit Pulse Templates

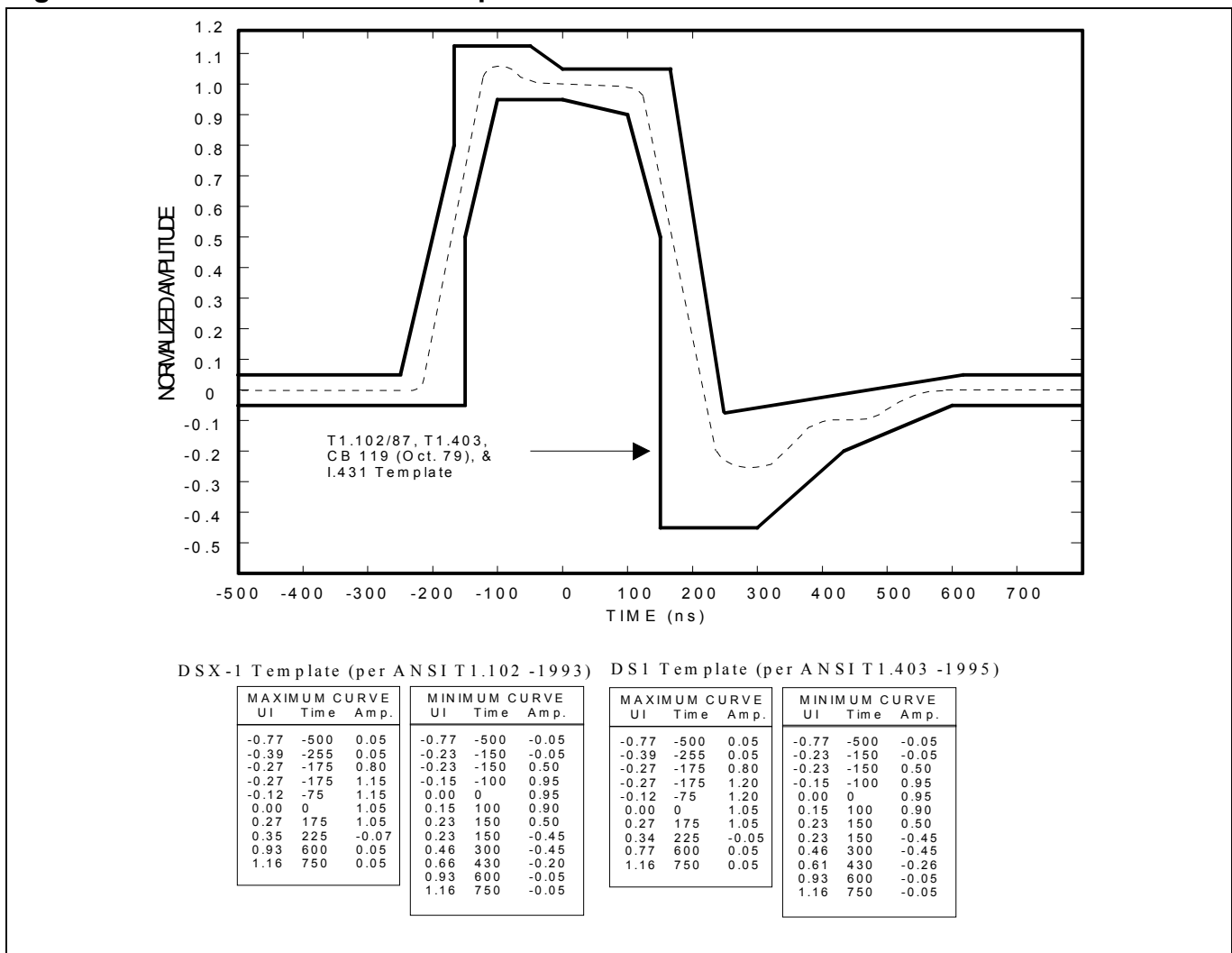
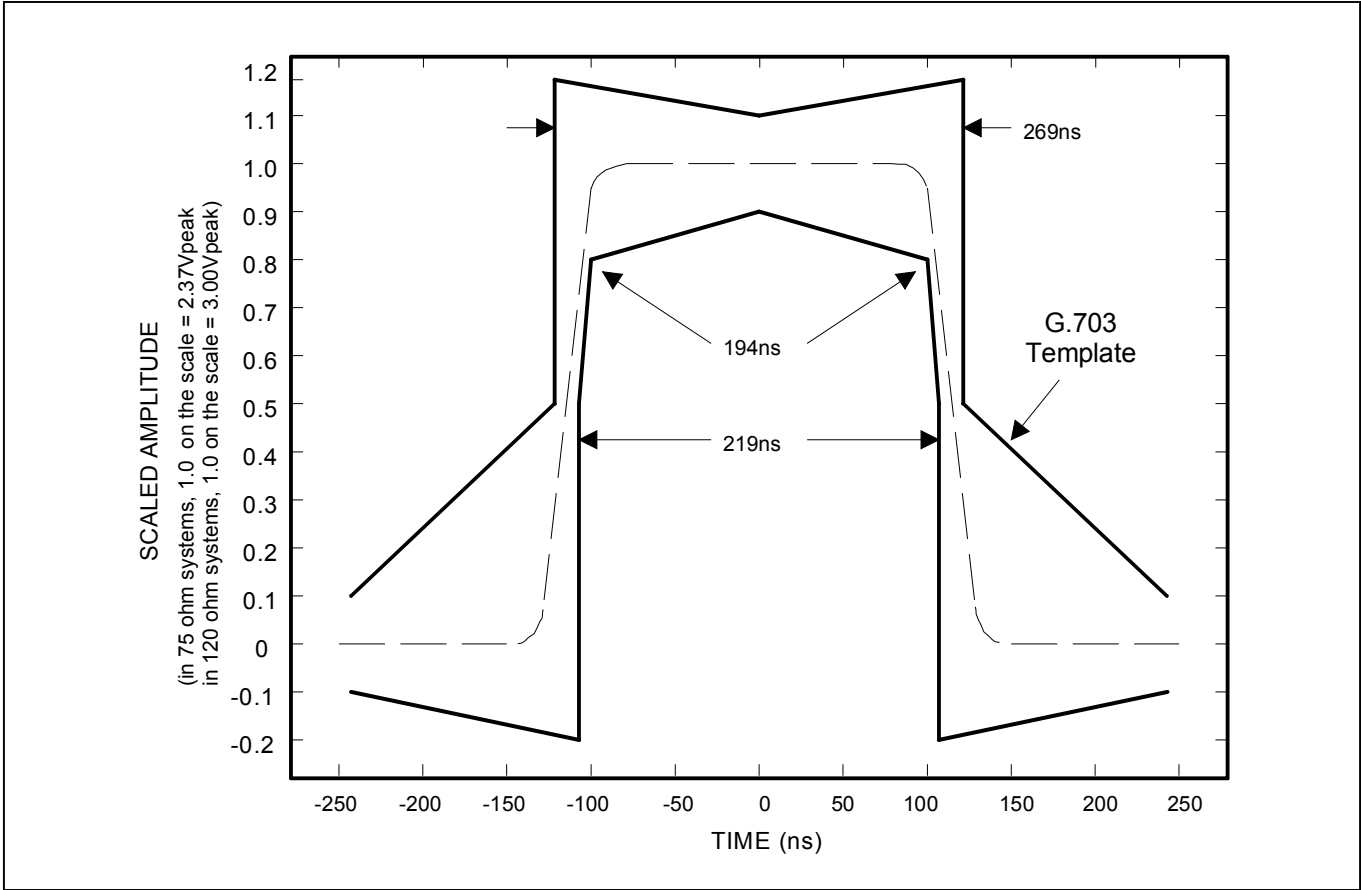

Figure 6-3 E1 Transmit Pulse Templates



6.3.2 LIU Transmit Front End

It is recommended to configure the transmitter's LIU as described in [Figure 6-4](#) and in [Table 6-4](#). No series resistors are required. The transmitter has internal termination for E1, J1, and T1 modes.

Figure 6-4. LIU Front End

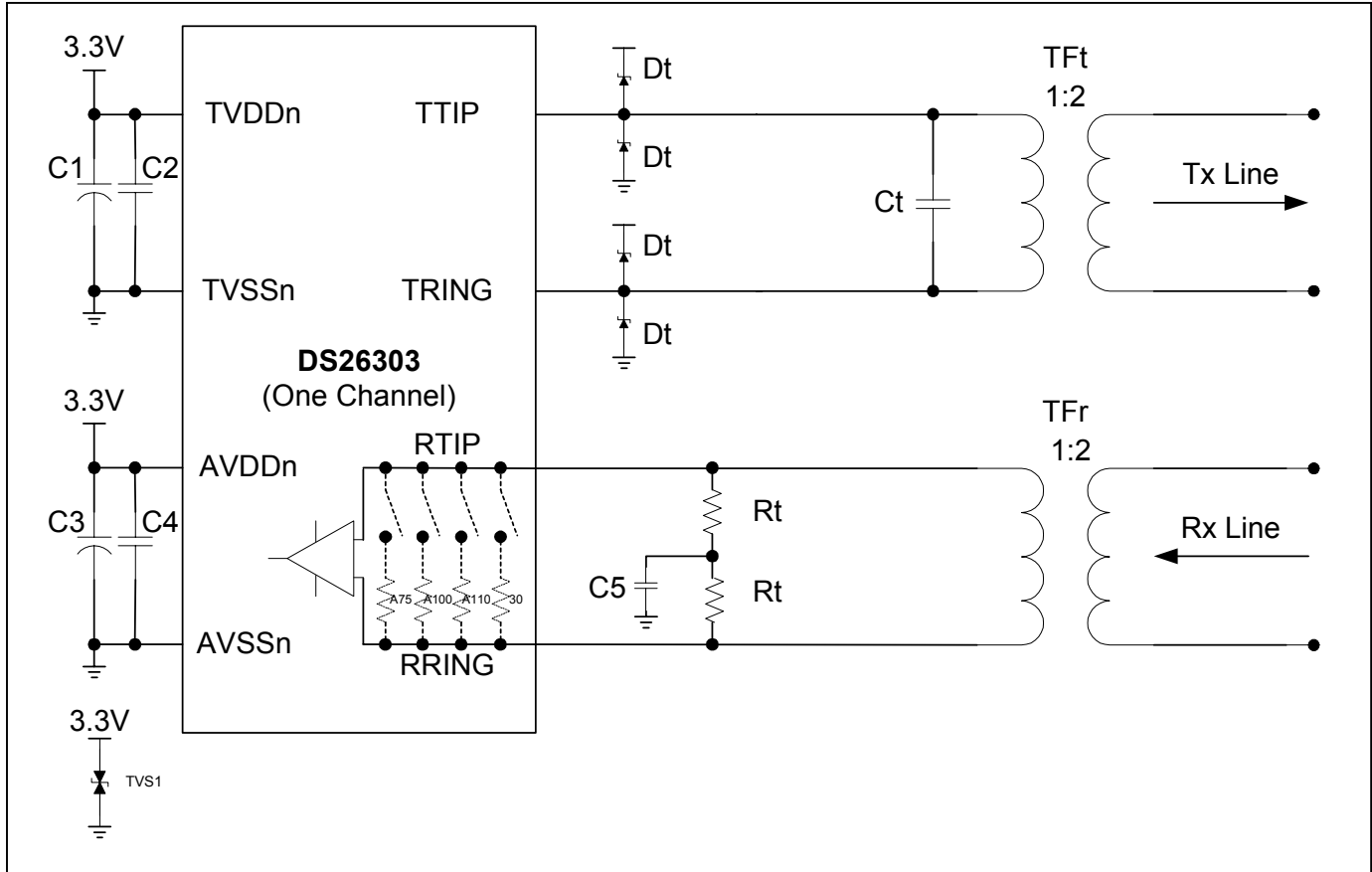

Table 6-4. LIU Front-End Values

MODE	COMPONENT	75Ω COAX	120Ω TWISTED PAIR	100Ω/110Ω TWISTED PAIR
Tx Capacitance	Ct	560pF typical. Adjust for board parasitics for optimal return loss.		
Tx Protection	Dt	International Rectifier: 11DQ04 or 10BQ060 Motorola: MBR0540T1		
Rx Transformer 1:2	TFr	Pulse: T1124 (0°C to +70°C)		
Tx Transformer 1:2	TfT	Pulse: T1114 (-40°C to +85°C)		
Tx Decoupling (ATVDD)	C1	Common decoupling for all eight channels is 68μF.		
Tx Decoupling (ATVDD)	C2	Recommended decoupling per channel is 0.1μF.		
Rx Decoupling (AVDDn)	C3	Common decoupling for all eight channels is 68μF.		
Rx Decoupling (AVDDn)	C4	Common decoupling for all eight channels is 0.1μF.		
Rx Termination	C5	When in external impedance mode, Rx capacitance for all eight channels is 0.1μF. Do not populate if using internal impedance mode.		
Rx Termination	Rt	When in external impedance mode, the two resistors for all modes are 15.0Ω ±1%. Do not populate if using internal impedance mode.		
Voltage Protection	TVS1	SGS-Thomson: SMLVT 3V3 (3.3V transient suppressor)		

6.3.3 Dual-Rail Mode

Dual-rail mode consists of TPOS, TNEG, and TCLK pins on the system side. NRZ data is sampled on the falling edge of TCLK as shown in [Figure 10-12](#). The zero substitution B8ZS or HDB3 is not allowed. The TPOS/TNEG data is encoded in AMI format on the TTIP and TRING pins. The data that appears on the TPOS pin is output on TTIP and data on the TRING is output on TRING after pulse shaping. The single-rail-select register ([SRMS](#)) is used for selection of dual-rail or single-rail mode. The data that arrives at the TPOS and TNEG can be overwritten in the maintenance mode by setting the BERT Control Register ([BTCR](#)).

6.3.4 Single-Rail Mode

Single-rail mode consists of TPOS, TNEG, and TCLK pins on the system side. NRZ data is sampled on the falling edge of TCLK as shown in [Figure 10-12](#). The zero substitution B8ZS or HDB3 is allowed. The TPOS data is encoded in AMI format on the TTIP and TRING pins after pulse shaping. The single-rail-mode select ([SRMS](#)) is used for selection of dual-rail or single-rail mode. The data that arrives at the TPOS can be overwritten in the maintenance mode by setting in BERT control register ([BTCR](#)).

6.3.5 Zero Suppression—B8ZS or HDB3

B8ZS coding is available when the device is in T1 mode selected by the TS2, TS1, and TS0 bits in the [TS](#) register. Setting the LCS bit in the [LCS](#) register enables B8ZS. Note that if the individual LIU is configured in E1 mode, then HDB3 code substitution can be selected. Bipolar violations can be inserted via the TNEG/BPVI pin or transmit maintenance register settings only if B8ZS or HDB3 coding is turned off. B8ZS substitution is defined in ANSI T1.102 and HDB3 in ITUT G.703 standards.

6.3.6 Transmit Power-Down

The transmitter is powered down if the relevant bits in the [TPDE](#) register are set.

6.3.7 Transmit All Ones

When transmit all ones is invoked, continuous 1s are transmitted using MCLK as the timing reference. Data input at TPOS and TNEG is ignored. Transmit all ones can be sent by setting bits in the [TAOE](#) register. Transmit all ones are enabled if bits in register [ATAOS](#) are set and the corresponding receiver goes into an LOS state in the status register [LOSS](#).

6.3.8 Drive Failure Monitor

The Driver Fail Monitor is connected to the TTIP and TRING pins. It will detect a Short Circuit on the Secondary side of the Transmit Transformer. The drive current will be limited to 50 ma if a short circuit is detected. The [DFMS](#) status registers and the corresponding Interrupt and Enable Registers can be used to monitor the driver failure.

6.4 Receiver

The DS26303's eight receivers are all identical. A 2:1 transformer steps down the input from the line. The DS26303 is designed to be fully software-selectable for E1 and T1/J1 without the need to change any external resistors for the receive side. The output of the internal termination circuitry is fed into a peak detector.

The peak detector and data slicer process the received signal. The output of the data slicer goes to clock and data recovery. A 2.048/1.544 PLL is internally multiplied by 8 by another internal PLL and fed to the clock recovery system derives E1 or T1 clock. The clock-recovery system uses the clock from the PLL circuit to form an 8-times oversampler, which is used to recover the clock and data. This oversampling technique offers outstanding performance to meet jitter tolerance specifications. Depending on selection options, B8ZS/HDB3/AMI decoding is performed. These decoded data is provided to the system side in either single-rail or dual-rail mode. The selection of single rail or dual rail is done by settings in the [SRMS](#) register.

6.4.1 Peak Detector and Slicer

The slicer determines the polarity and presence of the received data. The output of the slicer is sent to the clock and data recovery circuitry for extraction of data and clock. The slicer has a built-in peak detector for determination of the slicing threshold.

6.4.2 Clock and Data Recovery

The resultant E1 or T1 clock derived from the 2.048/1.544 PLL (JACLK in) is internally multiplied by 16 by another internal PLL and fed to the clock recovery system. The clock recovery system uses the clock from the PLL circuit to form a 16-times oversampler, which is used to recover the clock and data. This oversampling technique offers outstanding performance to meet jitter tolerance specifications.

6.4.3 Loss of Signal

The DS26303 uses both the digital and analog loss-detection method in compliance with the latest T1.231 for T1/J1 and ITU G.775 or ETSI 300 233 for E1 mode of operation.

LOS is detected if the receiver level falls below a threshold analog voltage for a certain duration. Alternatively, this can be termed as having received zeros for a certain duration. The signal level and timing duration are defined in accordance with the T1.231 or G.775 or ETSI 300 233 specifications.

The loss-detection thresholds are based on cable loss of 15dB for both T1 and E1 mode. RCLK is replaced by MCLK when the receiver detects a loss of signal if the AISEL bit is set in the [GC](#) register, or if the [IAISEL](#) bit is set. The RPOS/RNEG data is replaced by an all-ones signal upon receiving an LOS to indicate AIS to the downstream device. The loss state is exited when the receiver detects a certain number of ones density at a higher signal level than the loss-detection level. The loss-detection-signal level and loss-reset-signal level are defined with a hysteresis to prevent the receiver from bouncing between LOS and no-LOS states.

The following table outlines the specifications governing the loss function.

Table 6-5. Loss Criteria T1.231, G.775, and ETSI 300 233 Specifications

CRITERIA	STANDARD		
	T1.231	ITU G.775	ETSI 300 233
Loss Detection	No pulses are detected for 175 \pm 75 bits.	No pulses are detected for duration of 10 to 255 bit periods.	No pulses are detected for a duration of 2048 bit periods or 1ms,
Loss Reset	Loss is terminated if a duration of 12.5% ones are detected over duration of 175 \pm 75 bits. Loss is not terminated if eight consecutive 0s are found if B8ZS encoding is used. If B8ZS is not used, loss is not terminated if 100 consecutive pulses are 0.	The incoming signal has transitions for duration of 10 to 255 bit periods.	Loss reset criteria is not defined.

6.4.3.1 ANSI T1.231 for T1 and J1 Modes

Loss is detected if the received signal level is less than 200mV for duration of 192 bit periods. LOS is reset if the all of the following criteria are met:

- 24 or more 1s are detected in a 192-bit period with a detection threshold of 300mV measured at RTIP and RRING.
- During the 192 bits less than 100 consecutive zeros are detected.
- Eight consecutive 0s are not detected if B8ZS is set.

6.4.3.2 ITU G.775 for E1 Modes

LOS is detected if the received signal level is less than 200mV for a continuous duration of 192 bit periods. LOS is reset if the receive signal level is greater than 300mV for a duration of 192 bit periods.

6.4.3.3 ETSI 300 233 for E1 Modes

LOS is detected if the received signal level is less than 200mV for a continuous duration of 2048 (1ms) bit periods. LOS is reset if the receive signal level is greater than 300mV for a duration of 192 bit periods.

6.4.4 AIS

[Table 6-6](#) outlines the DS26303 AIS-related specifications. [Table 6-7](#) states the AIS functionality in the DS26303. The registers related to the AIS detection are shown in [Table 6-8](#).

Table 6-6. AIS Criteria T1.231, G.775, and ETSI 300 233 Specifications

CRITERIA	STANDARD		
	ITU G.775 FOR E1	ETSI 300233 FOR E1	ANSI T1.231 FOR T1
AIS Detection	Two or fewer 0s in each of two consecutive 512-bit streams received.	Fewer than three 0s detected in 512-bit period.	Fewer than nine 0s detected in a 8192-bit period (a ones density of 99.9% over a period of 5.3ms) are received.
AIS Clearance	Three or more 0s in each of two consecutive 512-bit streams received.	Three or more 0s in a 512-bit period received.	Nine or more 0s detected in a 8192-bit period are received.

Table 6-7. AIS Detection and Reset Criteria

CRITERIA	STANDARD		
	ITU G.775 FOR E1	ETSI 300233 FOR E1	ANSI T1.231 FOR T1
AIS Detection	Two or fewer 0 in each of two consecutive 512-bit streams received.	Fewer than three 0s detected in 512-bit period.	Fewer than nine 0s contained in 8192 bits.
AIS Clearance	Three or more 0s in each of two consecutive 512-bit streams received.	Three or more 0s in a 512-bit period received.	Nine or more bits received in a 8192-bit stream.

Table 6-8. Registers Related to AIS Detection

REGISTER	ACRONYM POINTER	FUNCTIONALITY
LOS/AIS Criteria	LASCS	Section criteria for AIS. T1.231, G.775, ETSI 300233 for E1.
AIS Register	AIS	Set when AIS is detected.
AIS Enable Register	AISIE	If reset interrupt due to AIS is not generated.
AIS Interrupt	AIS!	Latched if there is a change in AIS and the Interrupt is enabled.

6.4.5 Bipolar Violation and Excessive Zero Detector

The DS26303 detects code violations, BPV, and excessive zero errors. The reporting of the errors is done through the pin RNEGn/CVn.

Excessive zeros are detected if eight consecutive 0s are detected with B8ZS enabled and four consecutive 0s are detected with HDB3 enabled. Excessive zero detection is selectable when single-rail mode and HDB3/B8ZS encoding/decoding is selected.

The bits in [EZDE](#) and [CVDEB](#) registers determine the combinations that are reported. [Table 6-9](#) outlines the functionality:

Table 6-9. BPV, Code Violation, and Excessive Zero Error Reporting

CONDITIONS	CVn PIN REPORTS
EZDE is reset, CVDEB is reset	BPV + code violation
EZDE is set, CVDEB is reset	BPV + code violation + excessive zero
EZDE is reset, CVDEB is set	BPV
EZDE is set, CVDEB is set	BPV + excessive zero

6.4.6 LIU Receiver Front End

It is recommended that the receiver be configured as per [Table 6-4](#) and [Figure 6-4](#). Internal or external mode for the receiver front end can be selected by register [GC.RIMPMS](#). When this bit is set to external mode the user is required to supply two 15Ω resistors as shown in [Figure 6-4](#). The internal adjust resistors A75, A100, and A110 will still be set in external mode if 75Ω, 100Ω, or 110Ω impedance is selected during template selection. However, the internal 30Ω resistor will be disconnected. If the user would like all the adjust resistors to be disconnected or any internal impedance matching, then the user should set the [TS.RIMPOFF](#) bit for each LIU or the RIMPOFF pin when in hardware mode.

6.5 Hitless-Protection Switching (HPS)

Many current redundancy protection implementations use mechanical relays to switch between primary and backup boards. The switching time in relays is typically in the milliseconds, making T1/E1 HPS impossible. The switching event likely causes frame-synchronization loss in any equipment downstream, affecting the quality of service. The same is also true for tri-stating mechanisms that use software or inactive clocks for the triggering of HPS.

The DS26303 LIU includes fast tri-statable outputs for TTIP and TRING and fast turn-off impedance matching for the RTIP and RRING within less than one bit cycle. The control logic is shown in [Figure 6-5](#). In software mode, the user can set the RHPMC bit, which allows the OE pin to control both the transmitter outputs and the receive impedance matching. This is a very useful function in that control can be done through a hardware pin, allowing a quick switch to the backup system for both the receiver and the transmitter. [Figure 6-6](#) shows a typical HPS application in software mode where the OE is used for control. In hardware mode, the receiver can have impedance matching turned off quickly by using the RIMPOFF pin, and the transmitter output can be turned off quickly by using the OE pin.

Figure 6-5. HPS Logic

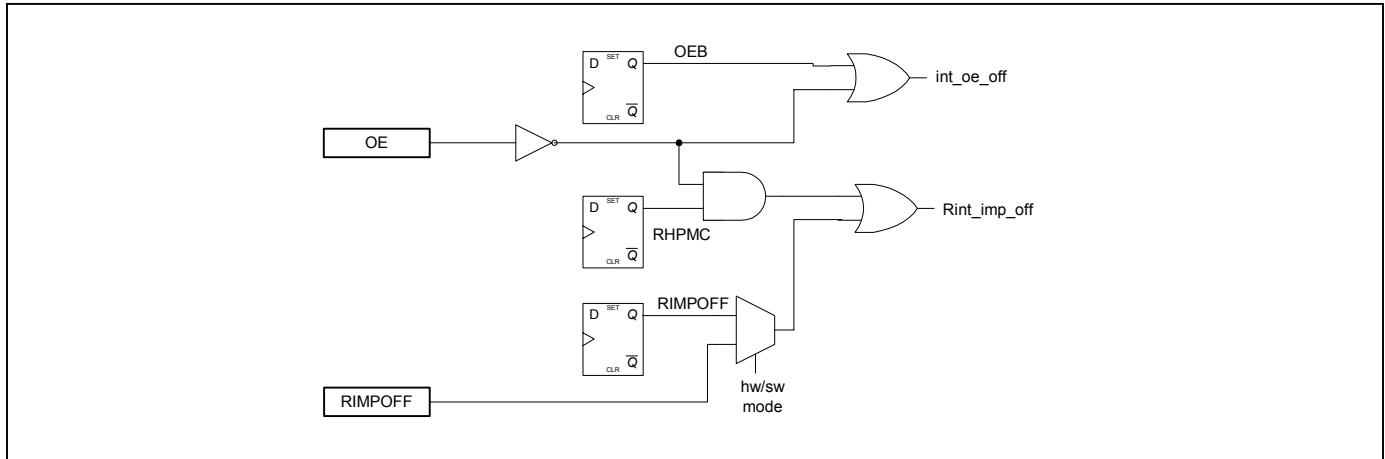
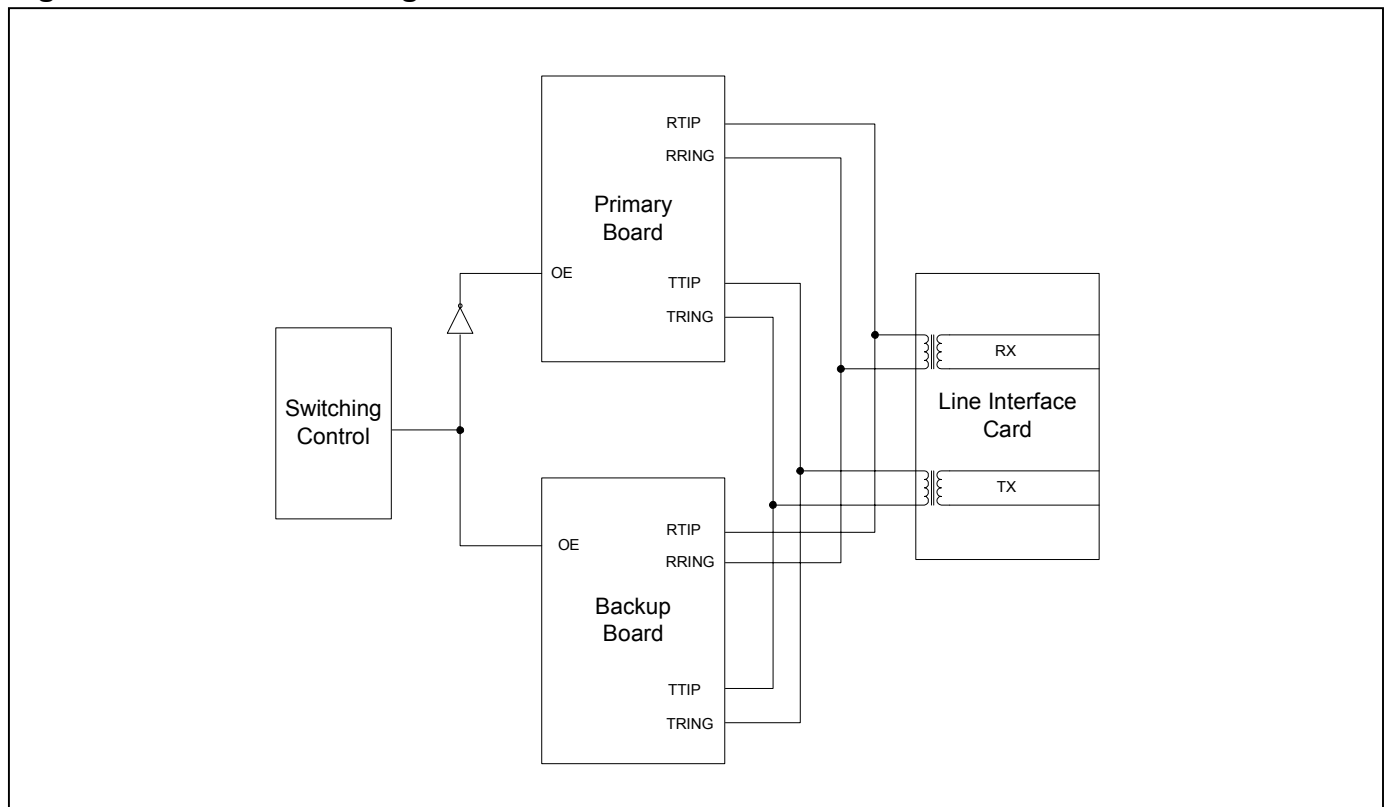

Figure 6-6. HPS Block Diagram



6.6 Jitter Attenuator

The DS26303 contains an on-board jitter attenuator that can be set to a depth of either 32 or 128 bits by the JADS bit in register [GC](#). It can also be controlled on an individual LIU basis by settings in the [JAFDS](#) register. The 128-bit mode is used in applications where large excursions of wander are expected. The 32-bit mode is used in delay-sensitive applications. The characteristics of the attenuation are shown in [Figure 6-7](#). The jitter attenuator can be placed in either the receive path or the transmit path or none by appropriately setting the JAPS and the JAE bits in register [GC](#). These selections can be changed on an individual LIU basis by settings in the [JAPS](#) and [JAE](#).

For the jitter attenuator to properly operate, a 2.048MHz or multiple thereof, or 1.544MHz clock or multiple thereof must be applied at MCLK. ITU specification G.703 requires an accuracy of ± 50 ppm for both T1 and E1 applications. TR62411 and ANSI specs require an accuracy of ± 32 ppm for T1 interfaces. On-board circuitry adjusts either the recovered clock from the clock/data recovery block or the clock applied at the TCLK pin to create a smooth jitter-free clock, which is used to clock data out of the jitter attenuator FIFO. It is acceptable to provide a gapped/bursty clock at the TCLK pin if the jitter attenuator is placed on the transmit side. If the incoming jitter exceeds either 120UI_{P-P} (buffer depth is 128 bits) or 28UI_{P-P} (buffer depth is 32 bits), then the DS26303 divides the internal nominal 32.768MHz (E1) or 24.704MHz (T1) clock by either 15 or 17 instead of the normal 16 to keep the buffer from overflowing. When the device divides by either 15 or 17, it also sets the jitter attenuator limit trip (JFLT) bits in the [JAFLT](#) register described.

Figure 6-7. Jitter Attenuation

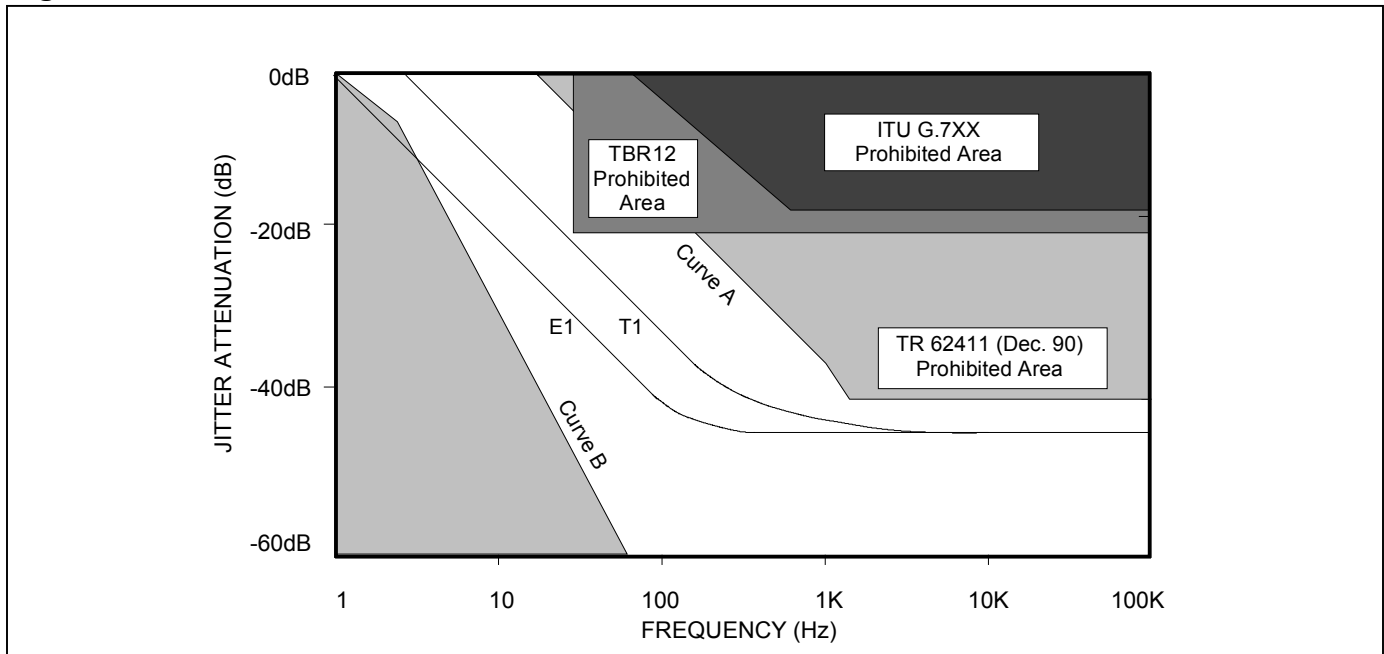

6.7 G.772 Monitor

In this application, only seven LIUs are functional and one LIU is used for nonintrusive monitoring of input and output of the other seven channels. Channel 1 is used for monitoring channels 2 to 8. G.772 monitoring is configured by the GMC register (see [Table 5-9](#)). While monitoring with channel 1, the device can be configured in remote loopback and the monitored signal can be output on TTIP1 and TRING1.

6.8 Loopbacks

The DS26303 provides four loopbacks for diagnostic purposes: analog loopback, digital loopback, remote loopback, and dual loopback.

6.8.1 Analog Loopback

The analog output of the transmitter TTIP and TRING is looped back to RTIP and RRING of the receiver. Data at RTIP and RRING is ignored in analog loopback. See [Figure 6-8](#).

Figure 6-8. Analog Loopback

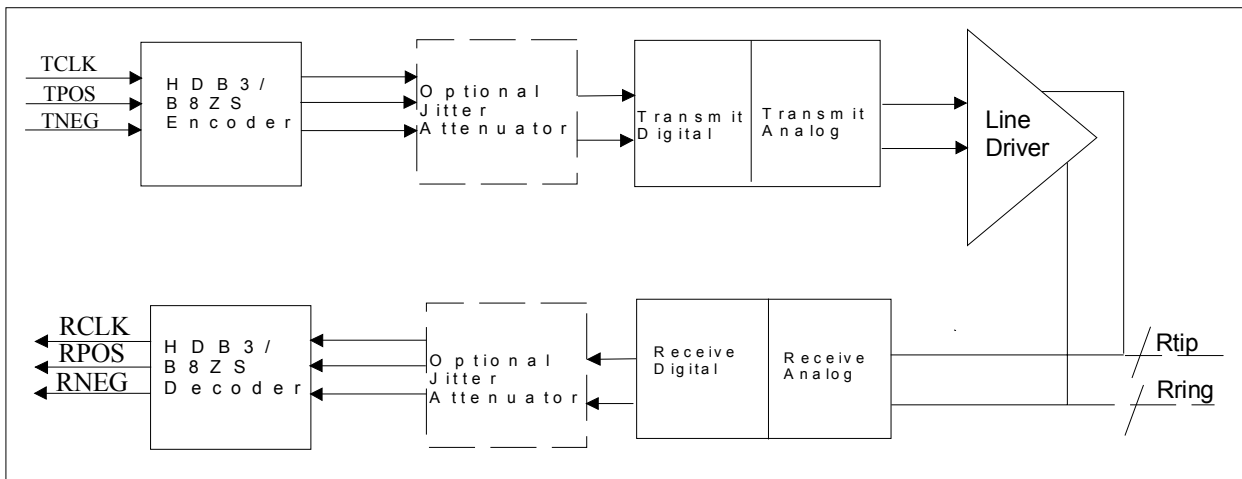

6.8.2 Digital Loopback

The transmit system data TPOS, TNEG, and TCLK are looped back to output on RCLK, RPOS, and RNEG. The data input at TPOS and TNEG is encoded and output on TTIP and TRING. Signals at RTIP and RRING are ignored. This loopback is conceptually shown in [Figure 6-9](#).

Figure 6-9. Digital Loopback

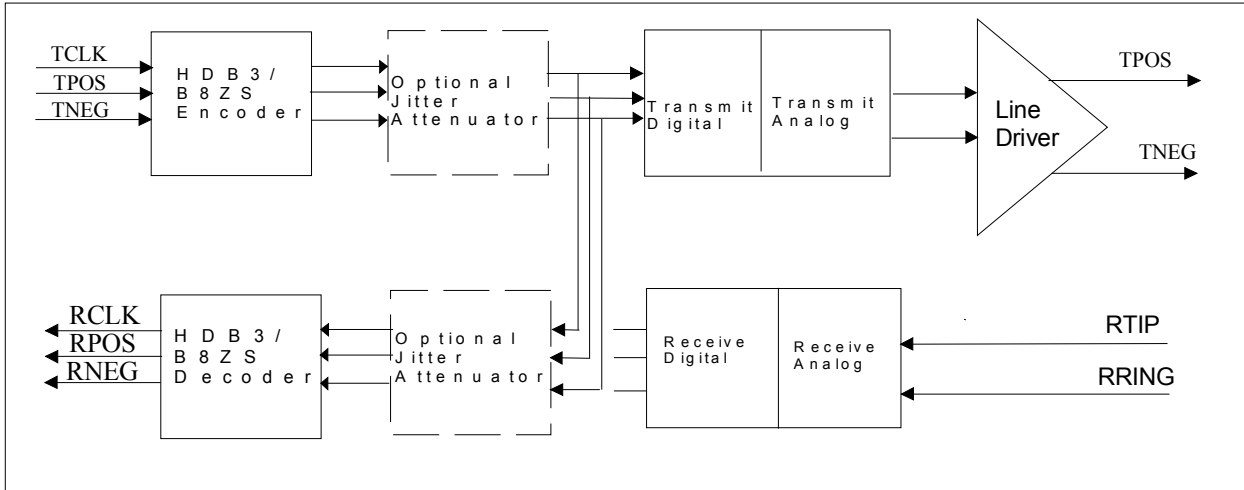

6.8.3 Remote Loopback

The inputs at RTIP and RRING are looped back to TTIP and TRING. The inputs at TCLK, TPOS, and TNEG are ignored during a remote loopback. This loopback is conceptually shown in [Figure 6-10](#).

Figure 6-10. Remote Loopback

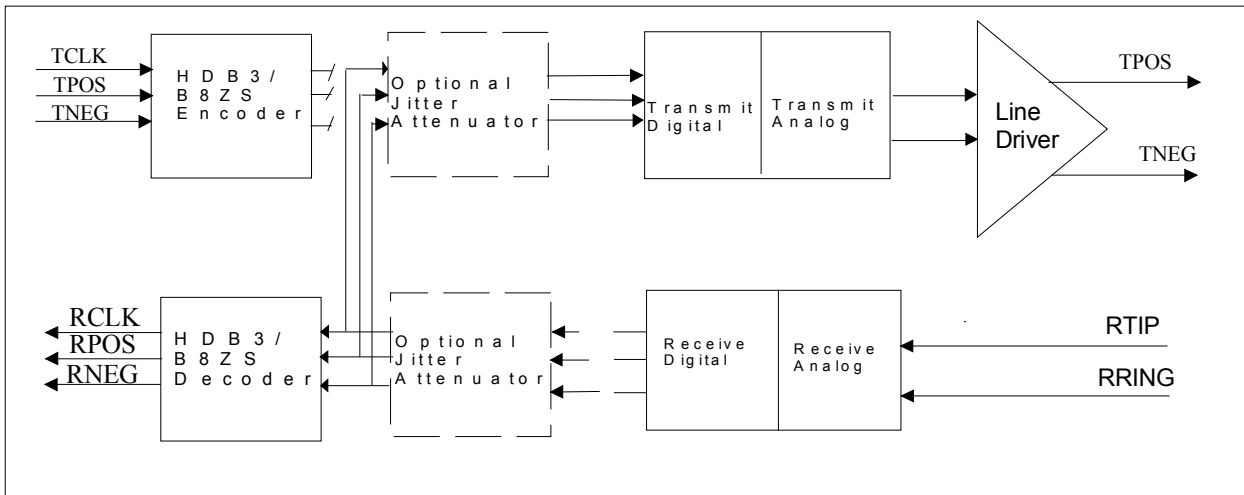

6.9 BERT

The BERT is a software-programmable test-pattern generator and monitor capable of meeting most error-performance requirements for digital transmission equipment. It generates and synchronizes to pseudorandom patterns with a generation polynomial of the form $x^n + x^y + 1$, where n and y can take on values from 1 to 32 and to repetitive patterns of any length up to 32 bits.

The transmit direction generates the programmable test pattern, and inserts the test pattern payload into the data stream.

The receive direction extracts the test pattern payload from the receive data stream, and monitors the test pattern payload for the programmable test pattern. The features include:

- **Programmable PRBS pattern.** The pseudorandom bit sequence (PRBS) polynomial ($x^n + x^y + 1$) and seed are programmable (length $n = 1$ to 32, tap $y = 1$ to $n - 1$, and seed = 0 to $2^n - 1$).
- **Programmable repetitive pattern.** The repetitive pattern length and pattern are programmable (the length $n = 1$ to 32 and pattern = 0 to $2^n - 1$).
- **24-bit error count and 32-bit bit count registers**
- **Programmable bit-error insertion.** Errors can be inserted individually, on a pin transition, or at a specific rate. The rate $1/10^n$ is programmable ($n = 1$ to 7).
- **Pattern synchronization at a 10^{-3} BER.** Pattern synchronization is achieved even in the presence of a random bit-error rate (BER) of 10^{-3} .

6.9.1 Configuration and Monitoring

Set *PORT.CR1.BENA* = 1 to enable the BERT. The following tables show how to configure the on-board BERT to send and receive common patterns.

Table 6-10. Pseudorandom Pattern Generation

PATTERN TYPE	BPCR REGISTER				BERT.PCR	BERT.SPR2	BERT.SPR1	BERT.CR TPIC, RPIC
	PTF[4:0] (hex)	PLF[4:0] (hex)	PTS	QRSS				
2^9-1 O.153 (511 type)	04	08	0	0	0x0408	0xFFFF	0xFFFF	0
$2^{11}-1$ O.152 and O.153 (2047 type)	08	0A	0	0	0x080A	0xFFFF	0xFFFF	0
$2^{15}-1$ O.151	0D	0E	0	0	0x0D0E	0xFFFF	0xFFFF	1
$2^{20}-1$ O.153	10	13	0	0	0x1013	0xFFFF	0xFFFF	0
$2^{20}-1$ O.151 QRSS	02	13	0	1	0x0253	0xFFFF	0xFFFF	0
$2^{23}-1$ O.151	11	16	0	0	0x1116	0xFFFF	0xFFFF	1

Table 6-11. Repetitive Pattern Generation

PATTERN TYPE	BPCR REGISTER				BERT.PCR	BERT.SPR2	BERT.SPR1
	PTF[4:0] (hex)	PLF[4:0] (hex)	PTS	QRSS			
All 1s	NA	00	1	0	0x0020	0xFFFF	0xFFFF
All 0s	NA	00	1	0	0x0020	0xFFFF	0xFFFFE
Alternating 1s and 0s	NA	01	1	0	0x0021	0xFFFF	0xFFFFE
Double alternating and 0s	NA	03	1	0	0x0023	0xFFFF	0xFFFFC
3 in 24	NA	17	1	0	0x0037	0xFF20	0x0022
1 in 16	NA	0F	1	0	0x002F	0xFFFF	0x0001
1 in 8	NA	07	1	0	0x0027	0xFFFF	0xFF01
1 in 4	NA	03	1	0	0x0023	0xFFFF	0xFFF1

After configuring these bits, the pattern must be loaded into the BERT. This is accomplished through a 0-to-1 transition on [BCR.TNPL](#) and [BCR.RNPL](#).

Monitoring the BERT requires reading the [BSR](#) register that contains the BEC bit and the OOS bit. The BEC bit is 1 when the bit-error counter is 1 or more. The OOS is 1 when the receive pattern generator is not synchronized to the incoming pattern, which will occur when it receives a minimum 6 bit errors within a 64-bit window. The receive BERT bit-count register ([RBCR](#)) and the receive BERT bit-error count register ([RBECECR](#)) are updated upon the reception of a performance-monitor update signal (e.g., [BCR.LPMU](#)). This signal updates the registers with the values of the counters since the last update and resets the counters.

6.9.2 Receive Pattern Detection

The receive BERT receives only the payload data and synchronizes the receive pattern generator to the incoming pattern. The receive pattern generator is a 32-bit shift register that shifts data from the least significant bit (LSB) or bit 1 to the most significant bit (MSB) or bit 32. The input to bit 1 is the feedback. For a PRBS pattern (generating polynomial $x^n + x^y + 1$), the feedback is an XOR of bit n and bit y . For a repetitive pattern (length n), the feedback is bit n . The values for n and y are individually programmable (1 to 32). The output of the receive pattern generator is the feedback. If QRSS is enabled, the feedback is an XOR of bits 17 and 20, and the output is forced to 1 if the next 14 bits are all 0s. QRSS is programmable (on or off). For PRBS and QRSS patterns, the feedback is forced to 1 if bits 1 through 31 are all 0s. Depending on the type of pattern programmed, pattern detection performs either PRBS synchronization or repetitive pattern synchronization.

6.9.2.1 Receive PRBS Synchronization

PRBS synchronization synchronizes the receive pattern generator to the incoming PRBS or QRSS pattern. The receive pattern generator is synchronized by loading 32 data stream bits into the receive pattern generator, and then checking the next 32 data stream bits. Synchronization is achieved if all 32 bits match the incoming pattern. If at least six incoming bits in the current 64-bit window do not match the receive pattern generator, automatic pattern re-synchronization is initiated. Automatic pattern resynchronization can be disabled.

Refer to [Figure 6-11](#) for the PRBS synchronization diagram.

Figure 6-11. PRBS Synchronization State Diagram

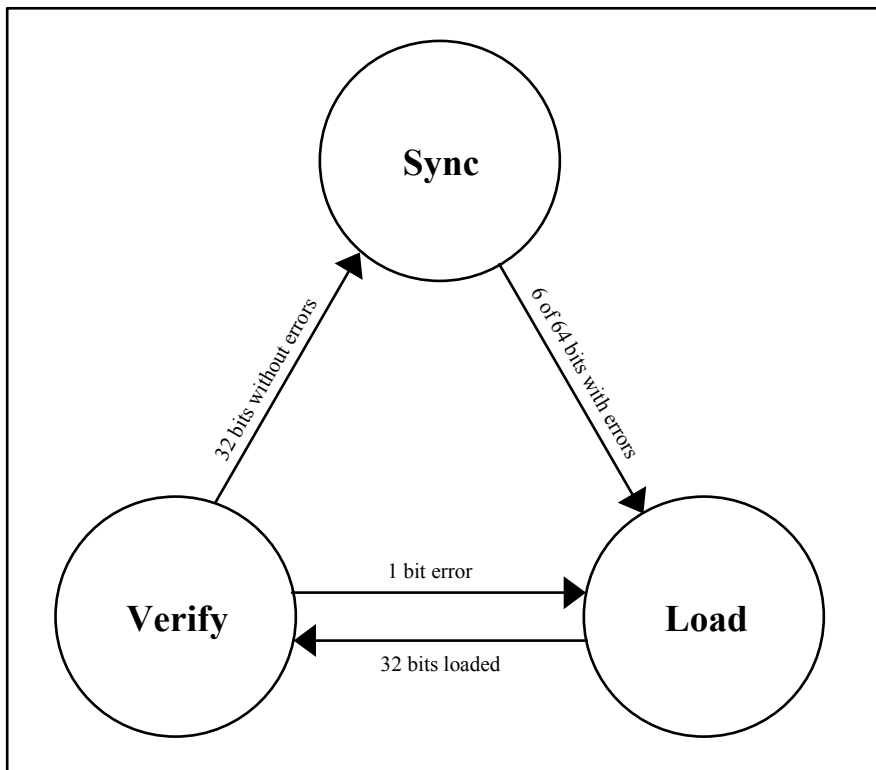

6.9.2.2 Receive Repetitive Pattern Synchronization

Repetitive pattern synchronization synchronizes the receive pattern generator to the incoming repetitive pattern. The receive pattern generator is synchronized by searching each incoming data stream bit position for the repetitive pattern, and then checking the next 32 data stream bits. Synchronization is achieved if all 32 bits match the incoming pattern. If at least six incoming bits in the current 64-bit window do not match the receive PRBS pattern generator, automatic pattern resynchronization is initiated. Automatic pattern resynchronization can be disabled.

See [Figure 6-12](#) for the repetitive pattern synchronization state diagram.

Figure 6-12. Repetitive Pattern Synchronization State Diagram

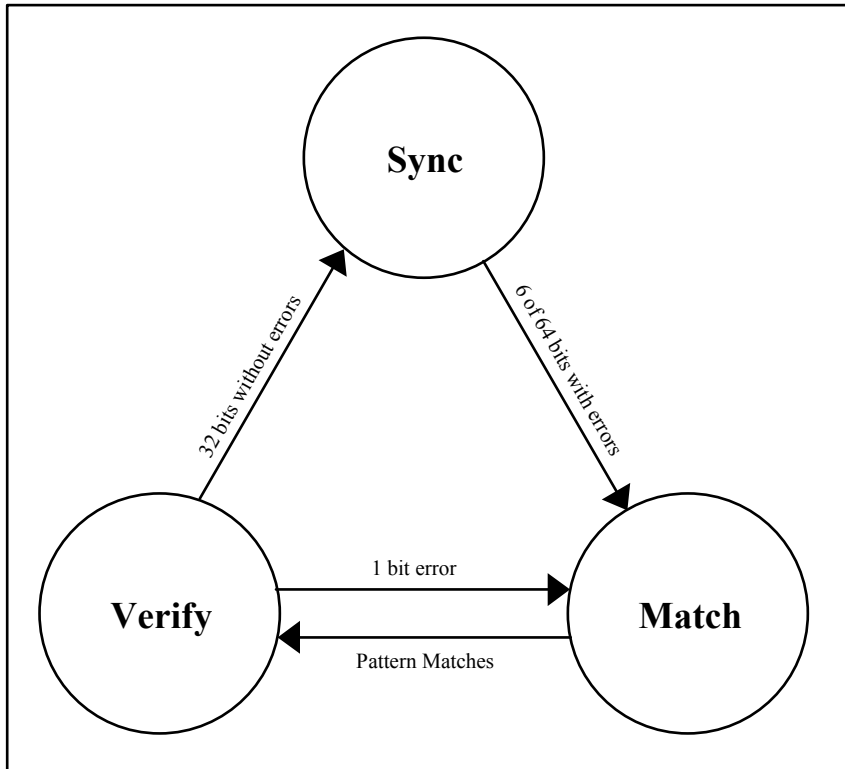

6.9.2.3 Receive Pattern Monitoring

Receive pattern monitoring monitors the incoming data stream for both an OOS condition and bit errors and counts the incoming bits. An out-of-synchronization (OOS) condition is declared when the synchronization state machine is not in the sync state. An OOS condition is terminated when the synchronization state machine is in the sync state.

Bit errors are determined by comparing the incoming data stream bit to the receive pattern generator output. If they do not match, a bit error is declared, and the bit error and bit counts are incremented. If they match, only the bit count is incremented. The bit count and bit-error count are not incremented when an OOS condition exists.

6.9.3 Transmit Pattern Generation

Pattern generation generates the outgoing test pattern and passes it onto error insertion. The transmit pattern generator is a 32-bit shift register that shifts data from the least significant bit (LSB) or bit 1 to the most significant bit (MSB) or bit 32. The input to bit 1 is the feedback. For a PRBS pattern (generating polynomial $x^n + x^y + 1$), the feedback is an XOR of bit n and bit y . For a repetitive pattern (length n), the feedback is bit n . The values for n and y are individually programmable (1 to 32). The output of the receive pattern generator is the feedback. If QRSS is enabled, the feedback is an XOR of bits 17 and 20, and the output will be forced to one if the next 14 bits are all 0s. QRSS is programmable (on or off). For PRBS and QRSS patterns, the feedback will be forced to 1 if bits 1 to 31

are all 0s. When a new pattern is loaded, the pattern generator is loaded with a seed/pattern value before pattern generation starts. The seed/pattern value is programmable ($0 - 2^n - 1$).

6.9.3.1 Transmit Error Insertion

Error insertion inserts errors into the outgoing pattern data stream. Errors are inserted one at a time or at a rate of one out of every 10^n bits. The value of n is programmable (1 to 7 or off). Single bit-error insertion can be initiated from the microprocessor interface, or by the manual error-insertion input (TMEI). The method of single error insertion is programmable (register or input). If pattern inversion is enabled, the data stream is inverted before the overhead/stuff bits are inserted. Pattern inversion is programmable (on or off).

6.10 Special Test Functions

This section is used for designer notes. Any special features or test functions that are for internal use or possible future features that may be needed should be documented here.

6.10.1 Metal Options

The DS26303 has a metal option to allow for pins D0 to D7 to be metal revised. The metal revision adds VDDIO/2 pullup and pulldown to pins D0 to D7. This has been added in case compatibility in hardware mode needs to match the LXT384 part.

7 JTAG BOUNDARY SCAN ARCHITECTURE AND TEST ACCESS PORT

The DS26303 IEEE 1149.1 design supports the standard instruction codes SAMPLE/PRELOAD, BYPASS, and EXTEST. Optional public instructions included are HIGHZ, CLAMP, and IDCODE. The DS26303 contains the following as required by IEEE 1149.1 Standard Test Access Port and Boundary Scan Architecture:

- Test Access Port (TAP)
- TAP Controller
- Instruction Register
- Bypass Register
- Boundary Scan Register
- Device Identification Register

Details on Boundary Scan Architecture and the Test Access Port can be found in IEEE 1149.1-1990, IEEE 1149.1a-1993, and IEEE 1149.1b-1994. The Test Access Port has the necessary interface pins: JTRSTB, TCLK, JTMS, JTDI, and JTDO. See the pin descriptions for details. For the latest BSDL file go to www.maxim-ic.com/tools/bsdl/ and search for DS26303.

Figure 7-1. JTAG Functional Block Diagram

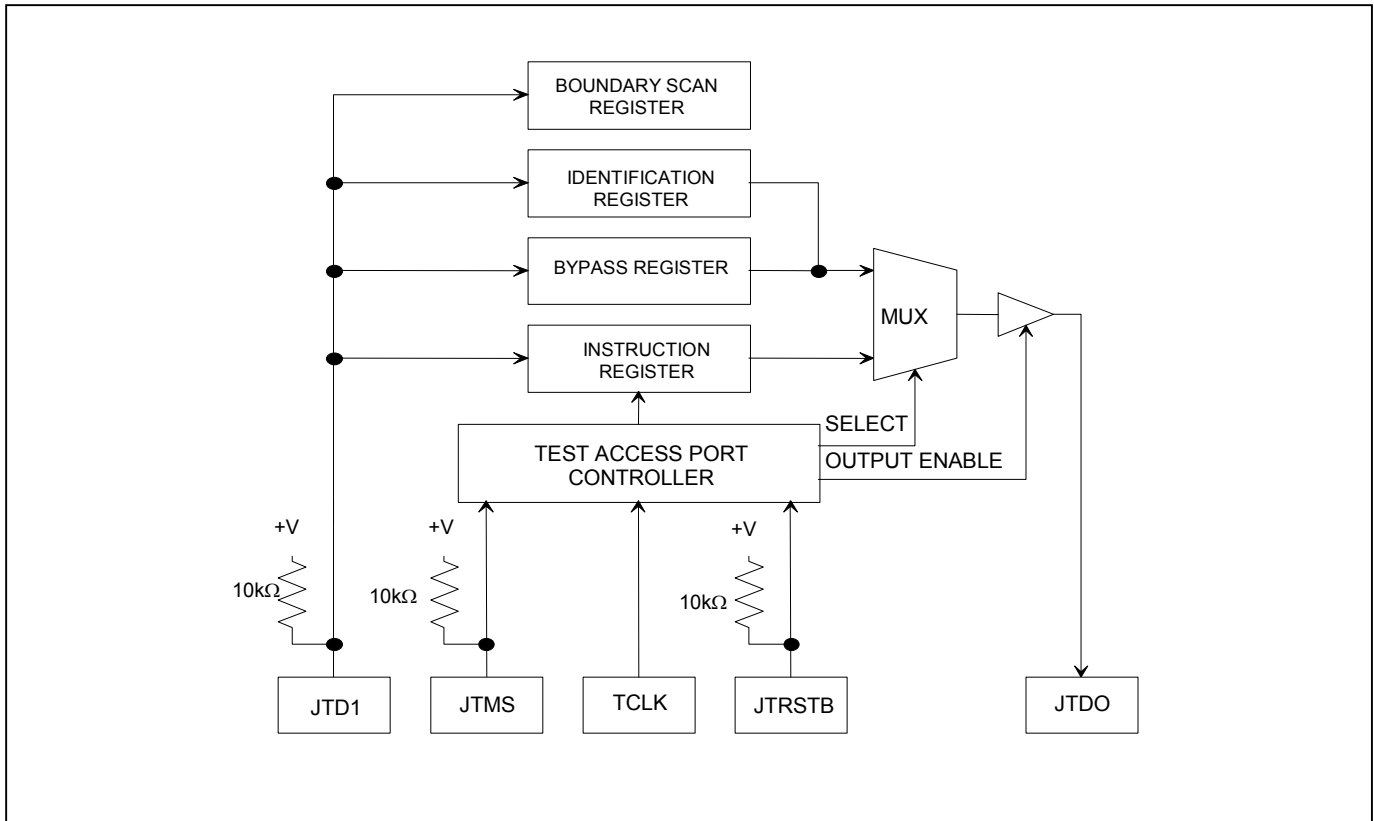

7.1 TAP Controller State Machine

The TAP controller is a finite state machine that responds to the logic level at JTMS on the rising edge of TCLK. The state diagram is shown in [Figure 7-2](#).

Test-Logic-Reset

Upon power-up, the TAP controller will be in the test-logic-reset state. The instruction register will contain the IDCODE instruction. All system logic of the device will operate normally. This state is automatically entered during power-up. This state is entered from any state if the JTMS is held high for at least 5 clocks.

Run-Test-Idle

The run-test-idle is used between scan operations or during specific tests. The instruction register and test registers will remain idle. The controller remains in this state when JTMS is held low. When the JTMS is high and rising edge of TCLK is applied the controller moves to the Select-DR-Scan State.

Select-DR-Scan

All test registers retain their previous state. With JTMS LOW, a rising edge of TCLK moves the controller into the capture-DR state and will initiate a scan sequence. JTMS HIGH during a rising edge on TCLK moves the controller to the select-IR-scan state.

Capture-DR

Data can be parallel-loaded into the test-data registers if the current instruction is EXTEST or SAMPLE/PRELOAD. If the instruction does not call for a parallel load or the selected register does not allow parallel loads, the test register will remain at its current value. On the rising edge of TCLK, the controller will go to the shift-DR state if JTMS is LOW or it will go to the exit1-DR state if JTMS is HIGH.

Shift-DR

The test-data register selected by the current instruction will be connected between JTDI and JTDO and will shift data one stage towards its serial output on each rising edge of TCLK. If a test register selected by the current instruction is not placed in the serial path, it will maintain its previous state. When the TAP Controller is in this state and a rising edge of TCLK is applied, the controller enters the EXIT1-DR state if JTMS is high or remains in SHIFT-DR state if JTMS is low.

Exit1-DR

While in this state, a rising edge on TCLK will put the controller in the Update-DR state, which terminates the scanning process, if JTMS is HIGH. A rising edge on TCLK with JTMS LOW will put the controller in the Pause-DR state.

Pause-DR

Shifting of the test registers is halted while in this state. All test registers selected by the current instruction will retain their previous state. The controller will remain in this state while JTMS is LOW. A rising edge on TCLK with JTMS HIGH will put the controller in the exit2-DR state.

Exit2-DR

A rising edge on TCLK with JTMS HIGH while in this state will put the controller in the update-DR state and terminate the scanning process. A rising edge on TCLK with JTMS LOW will enter the shift-DR state.

Update-DR

A falling edge on TCLK while in the update-DR state will latch the data from the shift register path of the test registers into the data output latches. This prevents changes at the parallel output due to changes in the shift register.

Select-IR-Scan

All test registers retain their previous state. The instruction register will remain unchanged during this state. With JTMS LOW, a rising edge on TCLK moves the controller into the capture-IR state and will initiate a scan sequence for the instruction register. JTMS HIGH during a rising edge on TCLK puts the controller back into the Test-logic-reset state.

Capture-IR

The capture-IR state is used to load the shift register in the instruction register with a fixed value. This value is loaded on the rising edge of TCLK. If JTMS is HIGH on the rising edge of TCLK, the controller will enter the exit1-IR state. If JTMS is LOW on the rising edge of TCLK, the controller will enter the shift-IR state.

Shift-IR

In this state, the shift register in the instruction register is connected between JTDI and JTDO and shifts data one stage for every rising edge of TCLK towards the serial output. The parallel registers as well as all test registers remain at their previous states. A rising edge on TCLK with JTMS HIGH will move the controller to the exit1-IR state. A rising edge on TCLK with JTMS LOW will keep the controller in the shift-IR state while moving data one stage through the instruction shift register.

Exit1-IR

A rising edge on TCLK with JTMS LOW will put the controller in the pause-IR state. If JTMS is HIGH on the rising edge of TCLK, the controller will enter the update-IR state and terminate the scanning process.

Pause-IR

Shifting of the instruction shift register is halted temporarily. With JTMS HIGH, a rising edge on TCLK will put the controller in the Exit2-IR state. The controller will remain in the Pause-IR state if JTMS is LOW during a rising edge on TCLK.

Exit2-IR

A rising edge on TCLK with JTMS High will put the controller in the Update-IR state. The controller will loop back to shift-IR if JTMS is LOW during a rising edge of TCLK in this state.

Update-IR

The instruction code shifted into the instruction shift register is latched into the parallel output on the falling edge of TCLK as the controller enters this state. Once latched, this instruction becomes the current instruction. A rising edge on TCLK with JTMS LOW will put the controller in the run-test-idle state. With JTMS HIGH, the controller will enter the select-DR-scan state.

Figure 7-2. TAP Controller State Diagram

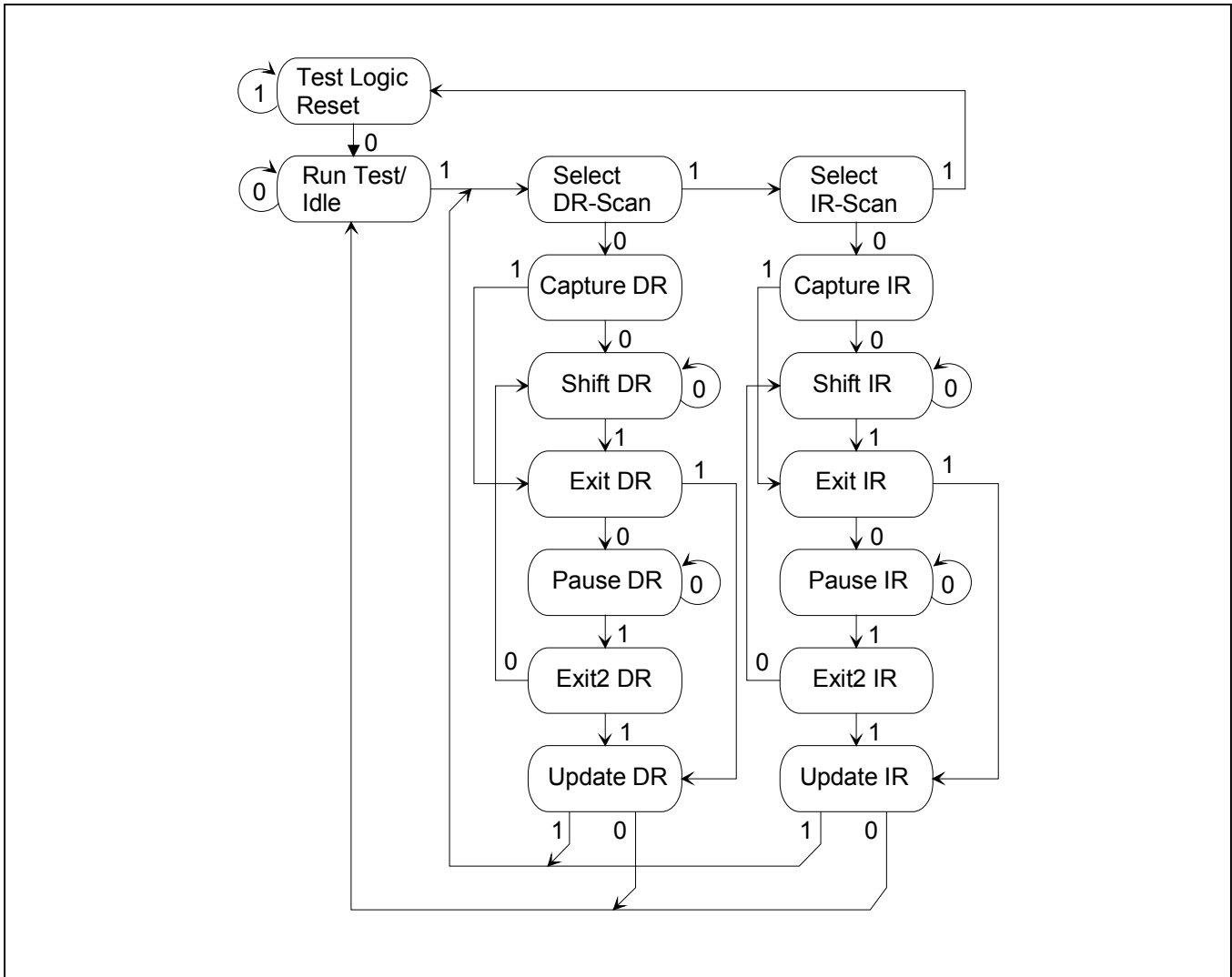

7.2 Instruction Register

The instruction register contains a shift register as well as a latched parallel output and is 3 bits in length. When the TAP controller enters the shift-IR state, the instruction shift register will be connected between JTDI and JTDO. While in the shift-IR state, a rising edge on TCLK with JTMS LOW will shift the data one stage towards the serial output at JTDO. A rising edge on TCLK in the exit1-IR state or the exit2-IR state with JTMS HIGH will move the controller to the update-IR state. The falling edge of that same TCLK will latch the data in the instruction shift register to the instruction parallel output. Instructions supported by the DS26303 and its respective operational binary codes are shown in [Table 7-1](#).

Table 7-1. Instruction Codes for IEEE 1149.1 Architecture

INSTRUCTION	SELECTED REGISTER	INSTRUCTION CODES
EXTEST	Boundary Scan	000
HIGHZ	Bypass	010
CLAMP	Bypass	011
SAMPLE/PRELOAD	Boundary Scan	100
IDCODE	Device Identification	110
BYPASS	Bypass	111

EXTEST

This allows testing of all interconnections to the device. When the EXTEST instruction is latched in the instruction register, the following actions occur. Once enabled via the Update-IR state, the parallel outputs of all digital output pins will be driven. The boundary scan register will be connected between JTDI and JTDO. The Capture-DR will sample all digital inputs into the boundary scan register.

HIGHZ

All digital outputs of the device will be placed in a HIGHZ state. The BYPASS register will be connected between JTDI and JTDO.

CLAMP

All digital outputs of the device will output data from the boundary scan parallel output while connecting the bypass register between JTDI and JTDO. The outputs will not change during the CLAMP instruction.

SAMPLE/PRELOAD

This is a mandatory instruction for the IEEE 1149.1 specification that supports two functions. The digital I/Os of the device can be sampled at the boundary scan register without interfering with the normal operation of the device by using the Capture-DR state. SAMPLE/PRELOAD also allows the device to shift data into the boundary scan register via JTDI using the Shift-DR state.

IDCODE

When the IDCODE instruction is latched into the parallel instruction register, the identification test register is selected. The device identification code will be loaded into the identification register on the rising edge of TCLK following entry into the capture-DR state. Shift-DR can be used to shift the identification code out serially via JTDO. During Test-Logic-Reset, the identification code is forced into the instruction register's parallel output. The ID code will always have a 1 in the LSB position. The next 11 bits identify the manufacturer's JEDEC number and number of continuation bytes followed by 16 bits for the device and 4 bits for the version [Table 7-2](#). [Table 7-3](#) lists the device ID code for the DS26303.

BYPASS

When the BYPASS instruction is latched into the parallel instruction register, JTDI connects to JTDO through the one-bit bypass test register. This allows data to pass from JTDI to JTDO not affecting the device's normal operation.

Table 7-2. ID Code Structure

MSB			LSB
Version Contact Factory	Device ID	JEDEC	1
4 bits	16 bits	00010100001	1

Table 7-3 Device ID Codes

PART	DIE REV	JTAG REV	JTAG ID
DS26303-075	A1	0h	0080h
DS26303-125	A1	0h	0081h

7.3 Test Registers

IEEE 1149.1 requires a minimum of two test registers: the bypass register and the boundary scan register. An optional test register has been included with the DS26303 design. This test register is the identification register and is used with the IDCODE instruction and the Test-Logic-Reset state of the TAP controller.

7.3.1 Boundary Scan Register

This register contains both a shift register path and a latched parallel output for all control cells and digital I/O cells and is n bits in length.

7.3.2 Bypass Register

This is a single 1-bit shift register used with the BYPASS, CLAMP, and HIGHZ instructions that provide a short path between JTDI and JTDO.

7.3.3 Identification Register

The identification register contains a 32-bit shift register and a 32-bit latched parallel output. This register is selected during the IDCODE instruction and when the TAP controller is in the test-logic-reset state. See [Table 7-2](#) and [Table 7-3](#) for more information about bit usage.

8 OPERATING PARAMETERS

ABSOLUTE MAXIMUM RATINGS

Voltage Range on Any Lead with Respect to V_{SS} (except V_{DD})	-0.3V to +5.5V
Supply Voltage (V_{DD}) Range with Respect to V_{SS}	-0.3V to +3.63V
Operating Temperature Range for DS26303G/DS26303L	0°C to +70°C
Operating Temperature Range for DS26303GN/DS26303LN	-40°C to +85°C
Storage Temperature	-55°C to +125°C
Soldering Temperature	See IPC/JEDEC J-STD-020 Specification

This is a stress rating only and functional operation of the device at these or any other conditions above those indicated in the operation sections of this specification is not implied. Exposure to absolute maximum rating conditions for extended periods of time may affect reliability.

Table 8-1. Recommended DC Operating Conditions

($T_A = -40^\circ\text{C}$ to $+85^\circ\text{C}$ for DS26303GN and DS26303LN.)

PARAMETER	SYMBOL	CONDITIONS	MIN	TYP	MAX	UNITS
Logic 1	V_{IH}		2			V
		(Note 1)	$\frac{2}{3}V_{DD} + 0.2$		5.5	
Logic 0	V_{IL}				0.8	V
		(Note 1)	-0.3		$\frac{1}{3}V_{DD} - 0.2$	
Midrange Level		(Note 1)	$\frac{1}{3}V_{DD} + 0.2$	$\frac{1}{2} \times V_{DD}$	$\frac{2}{3}V_{DD} - 0.2$	V
Supply Voltage	V_{DD}		3.135	3.3	3.465	V

Note 1: Applies to pins LP1–LP8, JAS, and MODESEL.

Table 8-2. Capacitance

($T_A = +25^\circ\text{C}$)

PARAMETER	SYMBOL	CONDITIONS	MIN	TYP	MAX	UNITS
Input Capacitance	C_{IN}			7		pF
Output Capacitance	C_{OUT}			7		pF

Table 8-3. DC Characteristics

($V_{DD} = 3.135\text{V}$ to 3.465V , $T_A = -40^\circ\text{C}$ to $+85^\circ\text{C}$.)

PARAMETER	SYMBOL	CONDITIONS	MIN	TYP	MAX	UNITS
Supply Current	I_{DD}	3.465V (Notes 1, 2)			478	mA
		3.3V		250		
Input Leakage	I_{IL}		-10.0		+10.0	μA
Tri-State Output Leakage	I_{OL}		-10.0		+10.0	μA
Output Voltage ($I_o = -4.0\text{mA}$)	V_{OH}		2.4			V
Output Voltage ($I_o = +4.0\text{mA}$)	V_{OL}				0.4	V

Note 1: RCLK1-n = TCLK1-n = 1.544MHz.

Note 2: Power dissipation with all ports active, TTIP and TRING driving a 25 Ω load, for an all-ones data density.

9 THERMAL CHARACTERISTICS

Table 9-1. Thermal Characteristics

PARAMETER	MIN	TYP	MAX	UNITS
Power Dissipation with RIMPMS = 0 (Notes 1, 2)		0.7	1.40	W
Power Dissipation with RIMPMS = 1(Notes 1, 2)		0.9	1.65	W
Ambient Temperature (Note 3)	-40		+85	°C
Junction Temperature			+125	°C
Theta-JA (θ_{JA}) in Still Air for 144-Pin eLQFP		+21.3 (Note 4)		°C/W
		29.0 (Note 5)		

Note 1: RCLK1-n = TCLK1-n = 1.544MHz.

Note 2: Power dissipation with all ports active, TTIP and TRIN driving a 25 Ω load, for an all-ones data density.

Note 3: The package is mounted on a four-layer JEDEC standard test board.

Note 4: Theta-JA (θ_{JA}) is the junction-to-ambient thermal resistance, when the package is mounted on a four-layer JEDEC standard test board and the die attach pad is soldered to the test board.

Note 5: Theta-JA (θ_{JA}) is the junction-to-ambient thermal resistance, when the package is mounted on a four-layer JEDEC standard test board and the die attach pad is not soldered to the test board.

10 AC CHARACTERISTICS

10.1 Line Interface Characteristics

Table 10-1. Transmitter Characteristics

PARAMETER	SYMBOL	CONDITIONS	MIN	TYP	MAX	UNITS
Output Mark Amplitude	V	E1 75Ω	2.14	2.37	2.6	V
		E1 120Ω	2.7	3.0	3.3	
		T1 100Ω	2.4	3.0	3.6	
		T1 110Ω	2.4	3.0	3.6	
Output Zero Amplitude (Note 1)	V _s		-0.3		+0.3	V
Transmit Amplitude Variation with Supply			-1		+1	%
Transmit Path Delay		Single rail		8		UI
		Dual rail		3		

Table 10-2. Receiver Characteristics

PARAMETER	SYMBOL	CONDITIONS	MIN	TYP	MAX	UNITS
Cable Attenuation	Attn				12	dB
Analog Loss-of-Signal Threshold Hysteresis Short-Haul Mode		(Note 1)		200		mV
				100		
Allowable Zeros Before Loss (Note 2)				192		
				192		
				2048		
Allowable Ones Before Loss (Note 3)				24		
				192		
				192		
Receive Path Delay		Dual rail		3		UI
		Single rail		8		

Note 1: Measured at the RRING and RTIP pins.

Note 2: 192 zeros for T1 and T1.231 specification compliance. 192 zeros for E1 and G.775 specification compliance. 2048 Zeros for ETSI 300 233 compliance.

Note 3: 24 ones in 192-bit period for T1.231. 192 ones for G.775, 192 ones for ETSI 300 233.

10.2 Parallel Host Interface Timing Characteristics

Table 10-3. Intel Read Mode Characteristics

($V_{DD} = 3.3V \pm 5\%$, $T_j = -40^\circ C$ to $+125^\circ C$.) (Figure 10-1 and Figure 10-2)

SIGNAL NAME(S)	SYMBOL	DESCRIPTION (NOTE 1)	MIN	TYP	MAX	UNITS
RDB	t1	Pulse Width	60			ns
CSB	t2	Setup Time to RDB	0			ns
CSB	t3	Hold Time from RDB	0			ns
AD[7:0]	t4	Setup Time to ALE	10			ns
A[5:0]	t5	Hold Time from RDB	0			ns
D[7:0], AD[7:0]	t6	Delay Time RDB, CSB Active	6		48	ns
D[7:0], AD[7:0]	t7	Deassert Delay from RDB, CSB Inactive	3		35	ns
RDYB	t8	Enable Delay Time from CSB Active	0		12	ns
RDYB	t9	Disable Delay Time from the CSB Inactive			12	ns
A[5:0]	t10	Setup Time to RDB Active	6			ns
ALE	t11	Pulse Width	10			ns
A[5:0]	t12	Hold Time from ALE	5			ns
RDB	t13	Output Delay Time of AD[7:0], D[7:0]	10		50	ns
RDYB	t14	Delay Time from RDB Inactive	0		12	ns
RDYB	t15	Active Output Delay Time from RDB	40		52	ns
ALE	t16	Inactive Time to RDB Active	2			ns

Note 1: The input/output timing reference level for all signals is $V_{DD}/2$.

Figure 10-1. Intel Nonmuxed Read Cycle

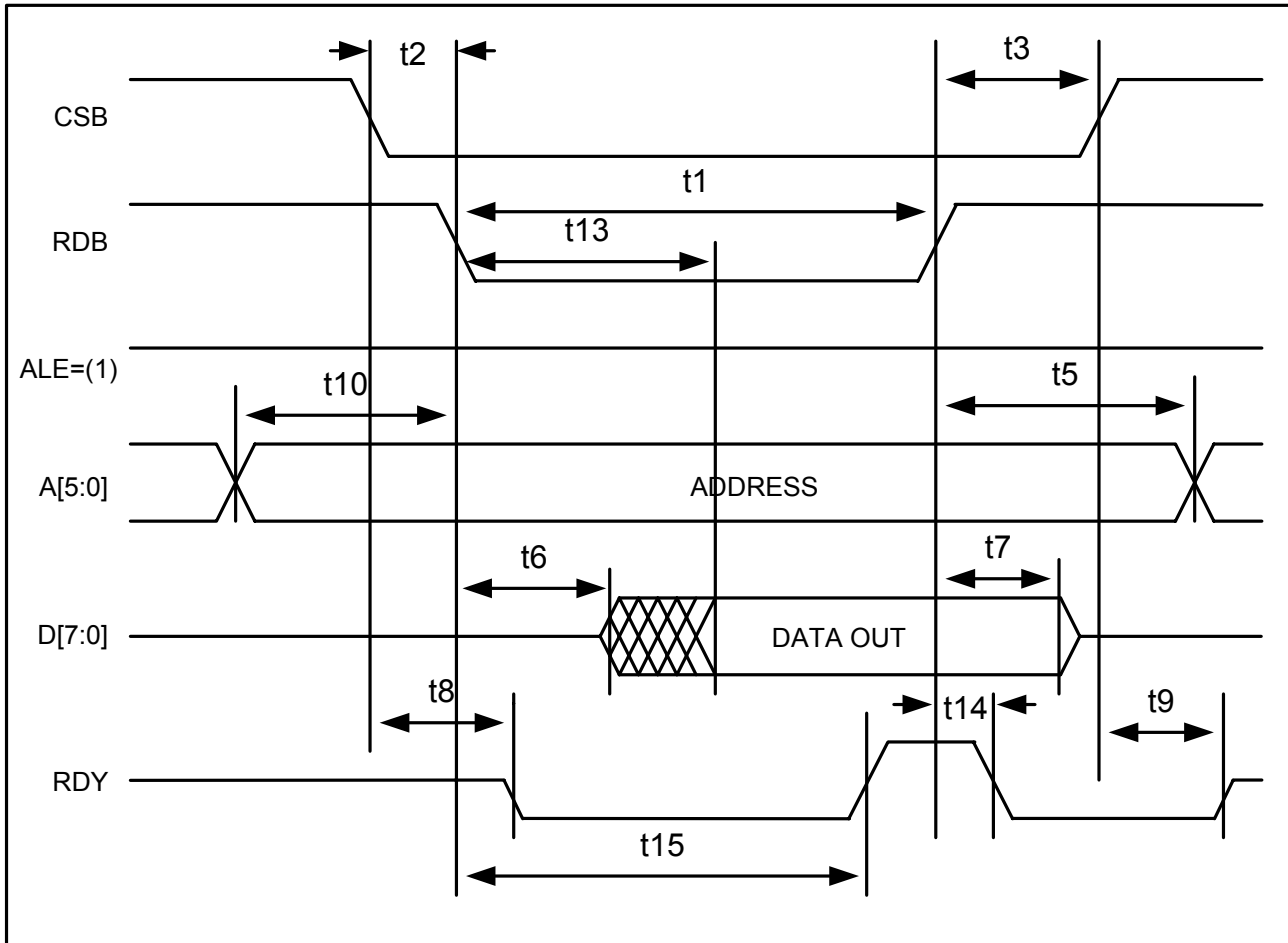

Figure 10-2. Intel Mux Read Cycle

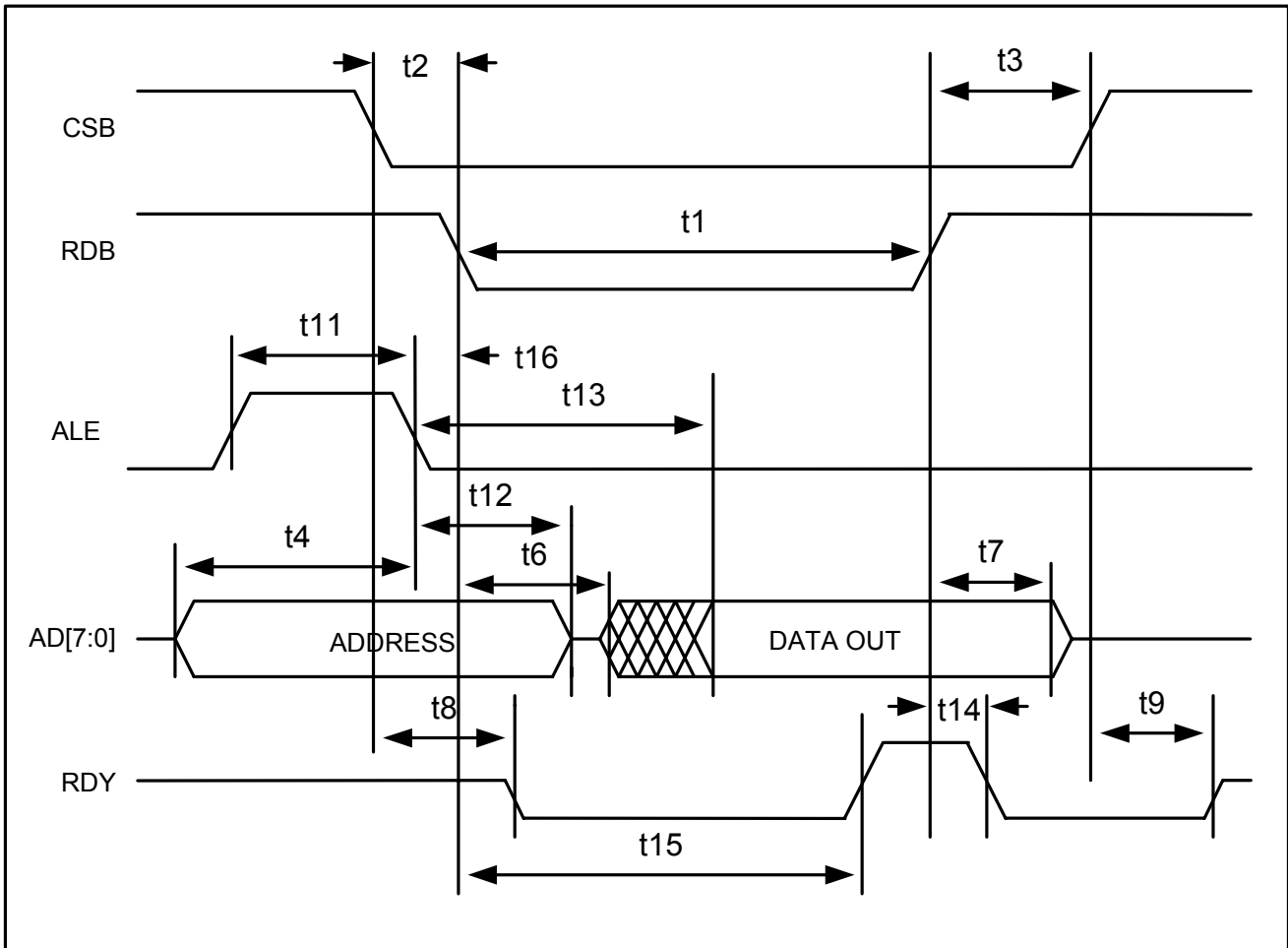

Table 10-4. Intel Write Cycle Characteristics(V_{DD} = 3.3V ±5%, T_j = -40°C to +125°C.) (Figure 10-3 and Figure 10-4)

SIGNAL NAME(S)	SYMBOL	DESCRIPTION (NOTE 1)	MIN	TYP	MAX	UNITS
WRB	t1	Pulse Width	60			ns
CSB	t2	Setup Time to WRB	0			ns
CSB	t3	Hold Time to WRB	0			ns
AD[7:0]	t4	Setup Time to ALE	10			ns
A[5:0]	t5	Hold Time from WRB Inactive	2			ns
D[7:0], AD[7:0]	t6	Input Setup time to WRB Inactive	40			ns
D[7:0], AD[7:0]	t7	Input Hold Time to WRB Inactive	30			ns
RDYB	t8	Enable Delay from CSB Active	0		13	ns
RDYB	t9	Delay Time from WRB Active	40			ns
RDYB	t10	Delay Time from WRB Inactive	0		12	ns
RDYB	t11	Disable Delay Time from CSB Inactive			12	ns
ALE	t12	Pulse Width	10			ns
ALE	t13	Inactive Time to WRB Active	10			ns
A[5:0]	t14	Hold Time from ALE Inactive	10			ns
A[5:0]	t15	Setup Time to WRB Inactive	17			ns

Note 1: The input/output timing reference level for all signals is V_{DD}/2.

Figure 10-3. Intel Nonmux Write Cycle

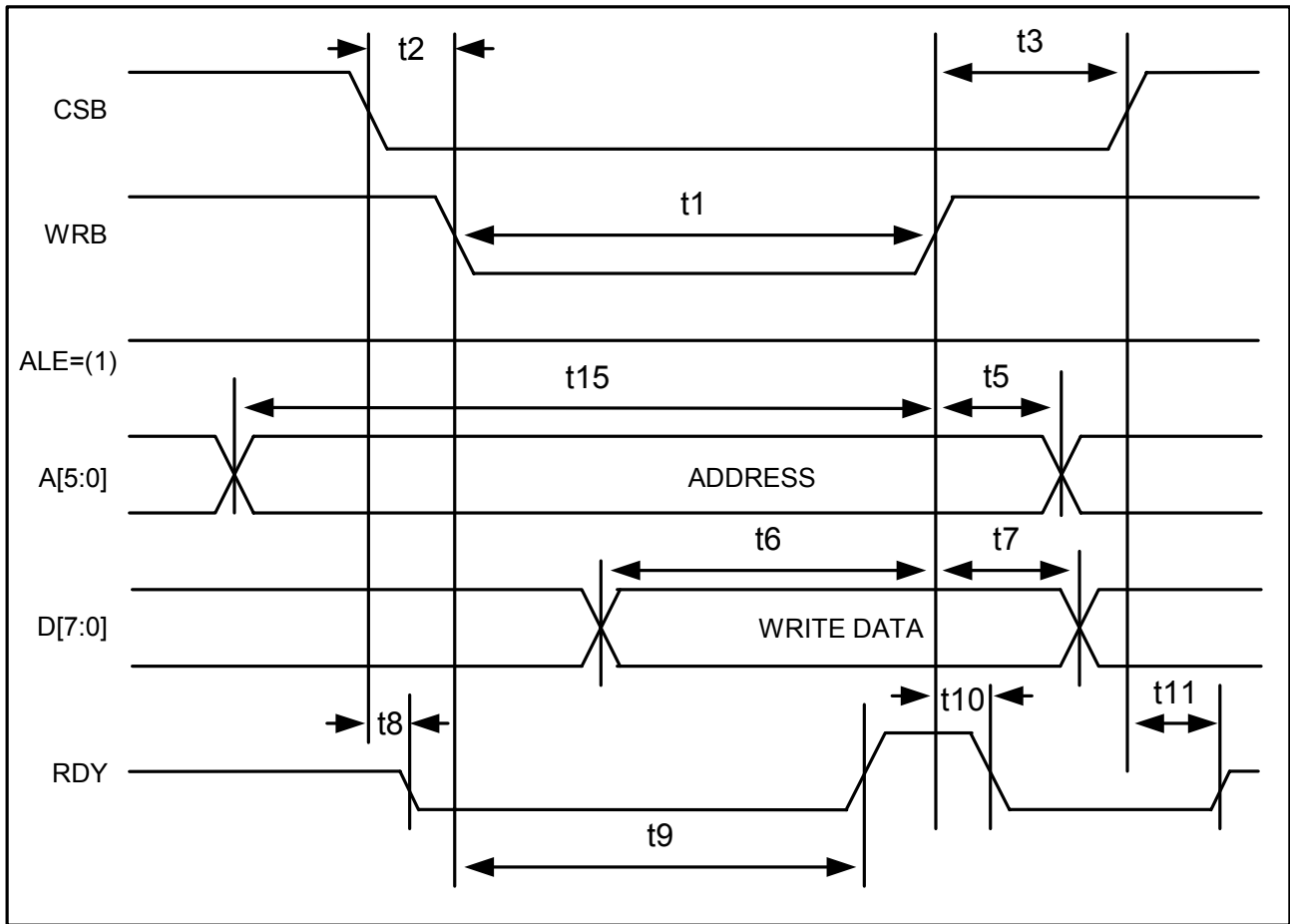

Figure 10-4. Intel Mux Write Cycle

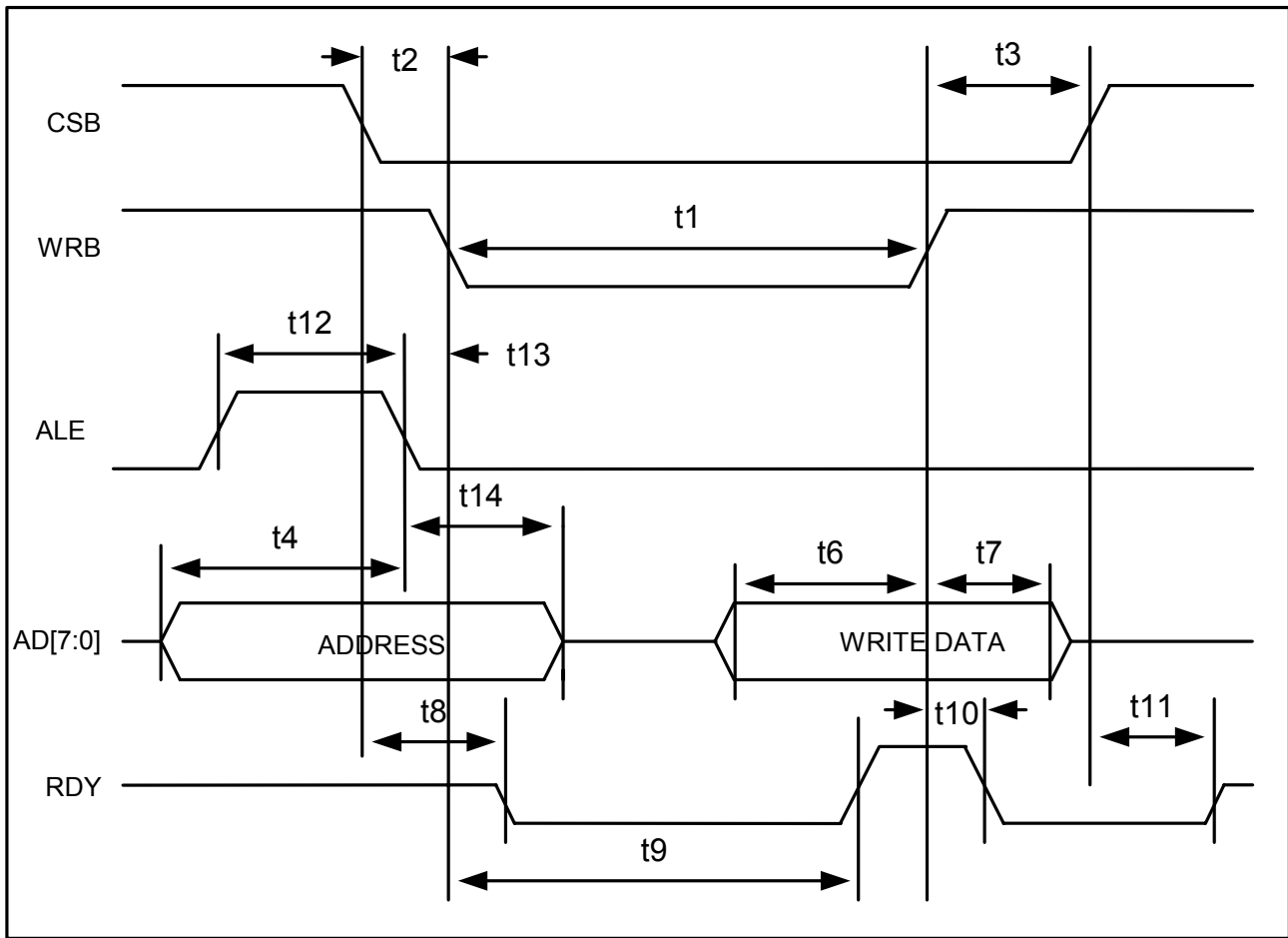

Table 10-5. Motorola Read Cycle Characteristics(V_{DD} = 3.3V ±5%, T_j = -40°C to +125°C.) ([Figure 10-5](#) and [Figure 10-6](#))

SIGNAL NAME(S)	SYMBOL	DESCRIPTION	MIN	TYP	MAX	UNITS
DS	t1	Pulse Width (Note 1)	60			ns
CSB	t2	Setup Time to DSB Active (Note 1)	0			ns
CSB	t3	Hold Time from DSB Inactive (Note 1)	0			ns
RWB	t4	Setup Time to DSB Active (Note 1)	10			ns
RWB	t5	Hold Time from DSB Inactive (Note 1)	0			ns
AD[7:0]	t6	Setup Time to ASB/DSB Active (Notes 1, 2)	10			ns
AD[7:0]	t7	Hold Time from ASB/DSB Active (Notes 1, 2)	5			ns
AD[7:0], D[7:0]	t8	Output Valid Delay Time from DSB Active (Note 1)	3		30	ns
AD[7:0], D[7:0]	t9	Invalid Output Delay Time from DSB Active (Note 1)	2			ns
AD[7:0], D[7:0]	t10	Output Valid Delay Time from DSB Inactive (Note 1)	3		30	ns
ACKB	t11	Asserted Delay from DSB Active (Note 1)			40	ns
ACKB	t12	Output Delay Time from DSB Inactive (Note 1)			12	ns
ASB	t13	Active Delay Time to DSB Active (Note 1)	10			ns

Note 1: The input/output timing reference level for all signals is V_{DD}/2.**Note 2:** In a nonmux cycle, the timing reference refers only to the DSB signal. While in a mux cycle, the timing reference refers only to the ASB signal.

Figure 10-5. Motorola Nonmux Read Cycle

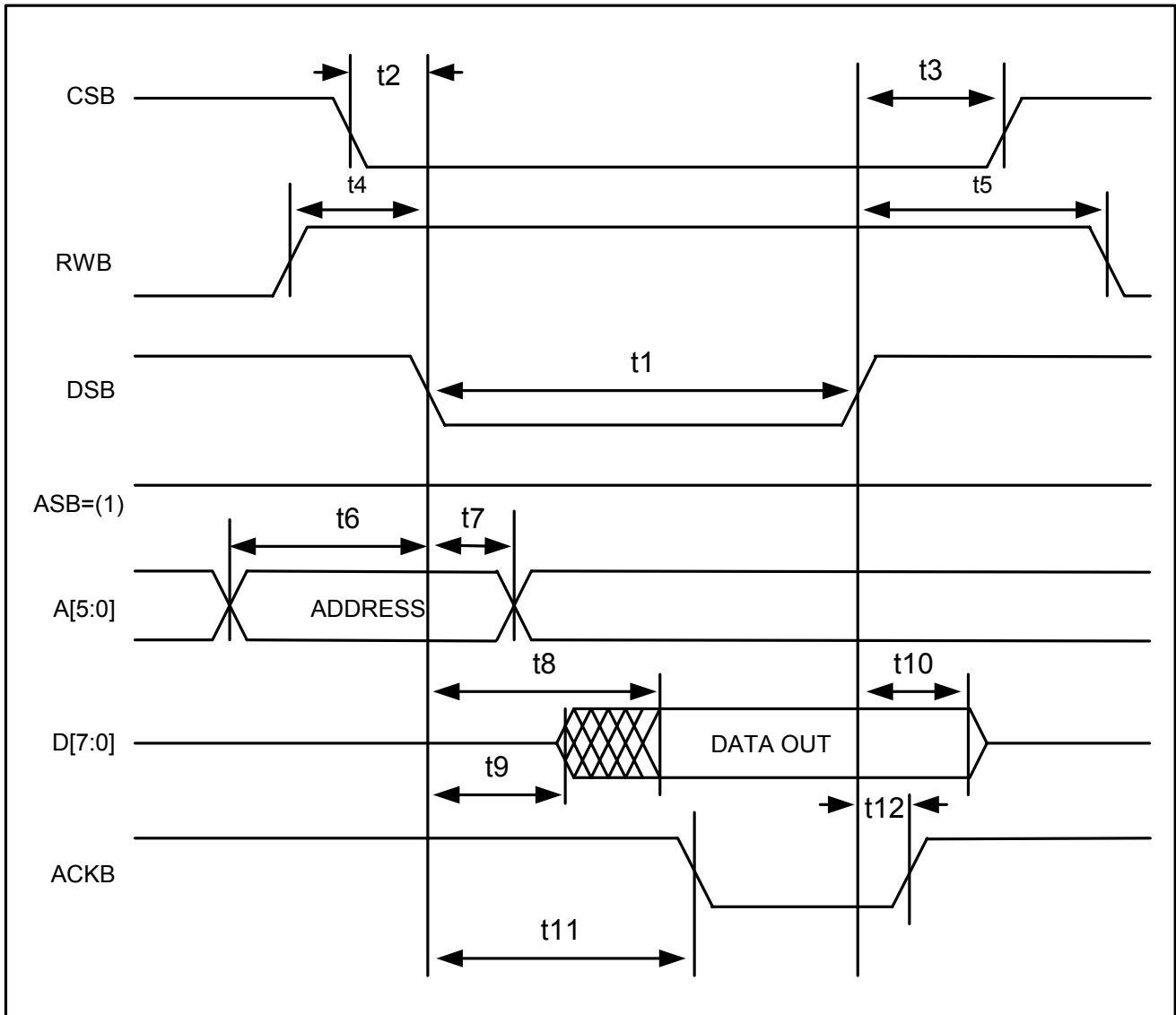

Figure 10-6. Motorola Mux Read Cycle

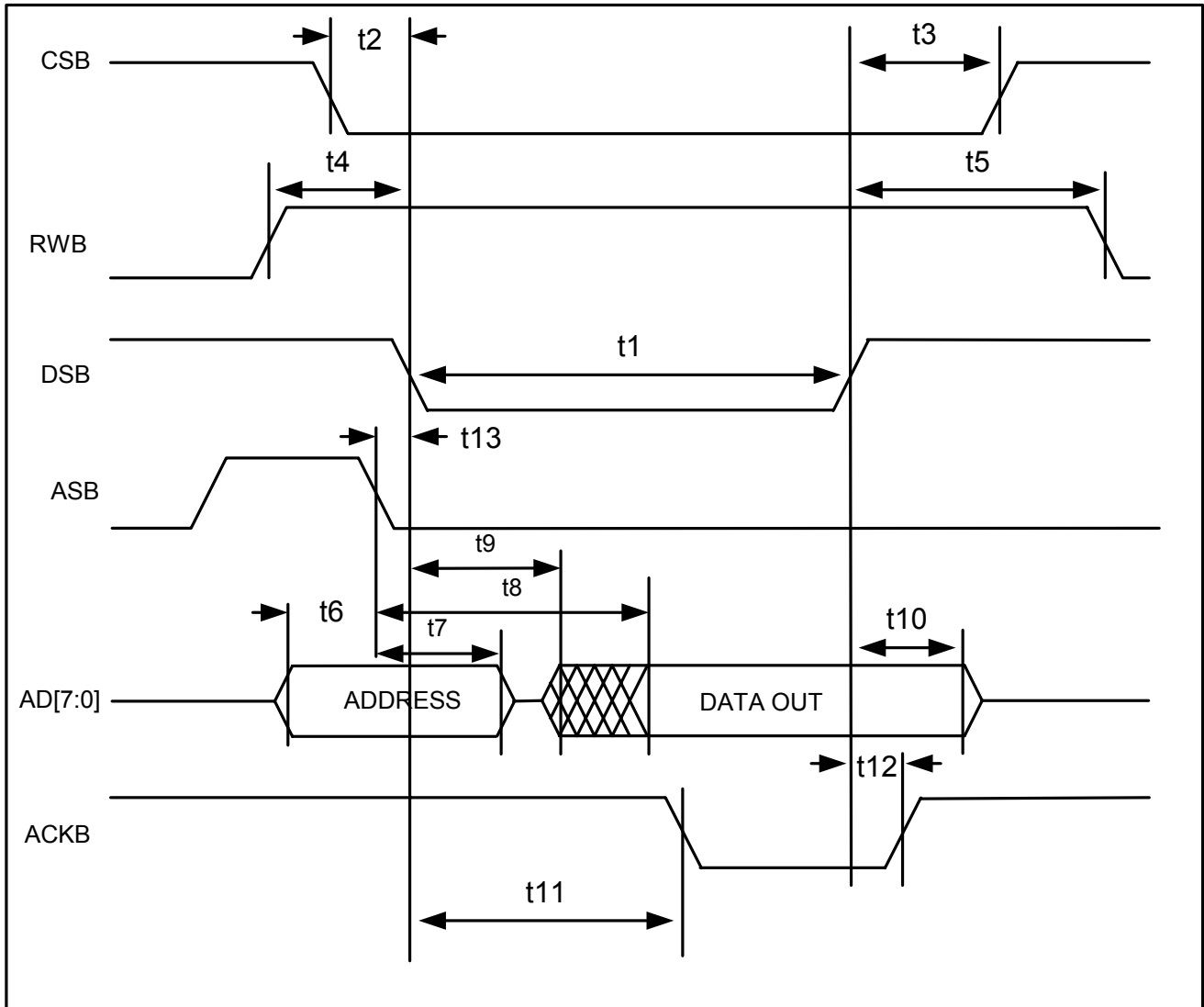

Table 10-6. Motorola Write Cycle Characteristics(V_{DD} = 3.3V ±5%, T_j = -40°C to +125°C.) ([Figure 10-7](#) and [Figure 10-8](#))

SIGNAL NAME(S)	SYMBOL	DESCRIPTION	MIN	TYP	MAX	UNITS
DSB	t1	Pulse Width (Note 1)	60			ns
CSB	t2	Setup Time to DSB Active (Note 1)	0			ns
CSB	t3	Hold Time from DSB Inactive (Note 1)	0			ns
RWB	t4	Setup Time to DSB Active (Note 1)	10			ns
RWB	t5	Hold Time to DSB Inactive (Note 1)	0			ns
AD[7:0]	t6	Setup Time to ASB/DSB Active (Notes 1, 2)	10			ns
AD[7:0]	t7	Hold Time from ASB/DSB Active (Notes 1, 2)	5			ns
AD[7:0], D[7:0]	t8	Setup Time to DSB Inactive (Note 1)	40			ns
AD[7:0], D[7:0]	t9	Hold Time from DSB Inactive (Note 1)	30			ns
A[5:0]	t10	Assert Time from DSB Active (Note 1)			40	ns
ACKB	t11	Output Delay from DSB Inactive (Note 1)	0		12	ns
ASB	t12	Active Time to DSB Active (Note 1)	10			ns

Note 1: The input/output timing reference level for all signals is V_{DD}/2.**Note 2:** In a nonmux cycle, the timing reference refers only to the DSB signal. While in a mux cycle, the timing reference refers only to the ASB signal.

Figure 10-7. Motorola Nonmux Write Cycle

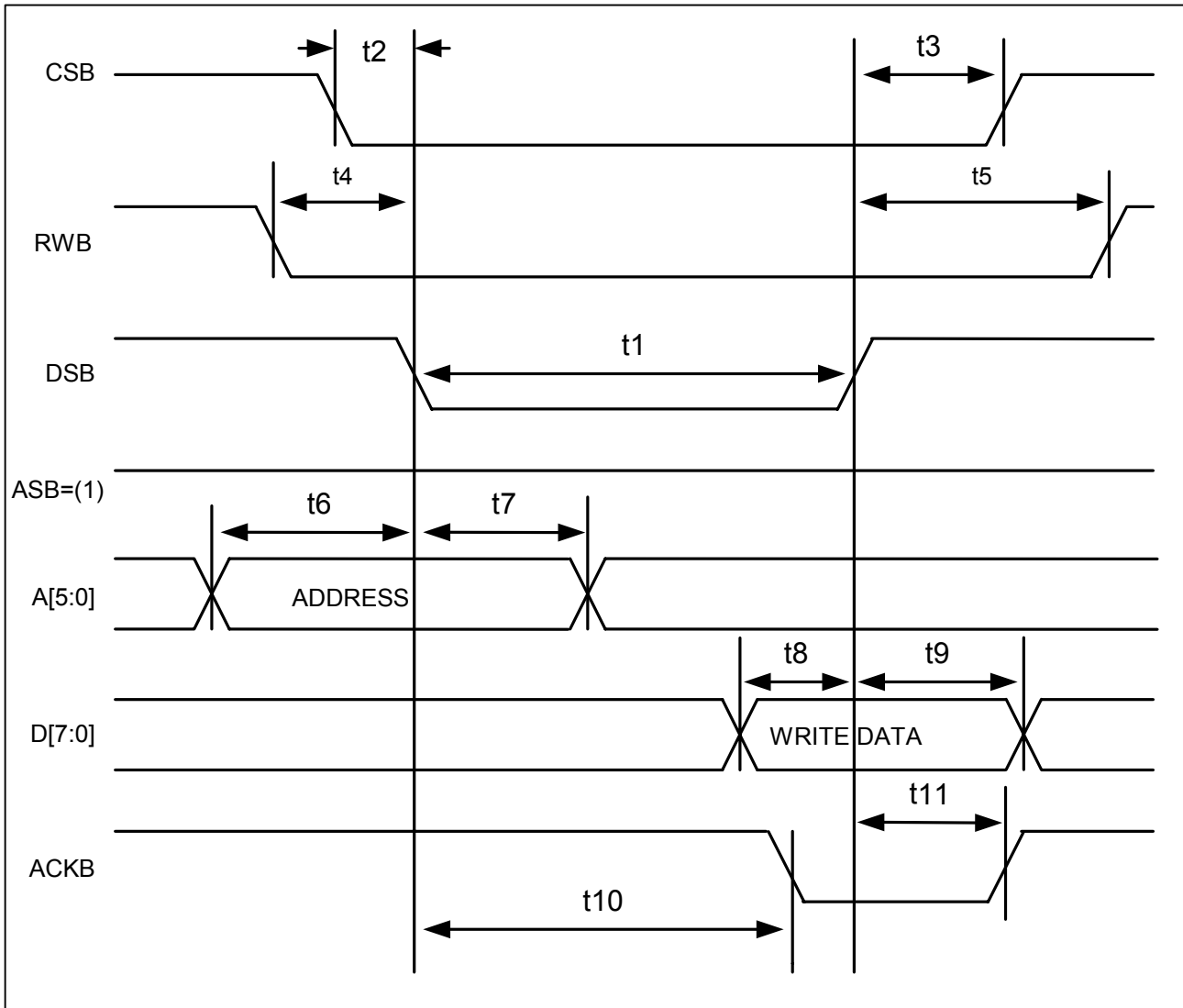
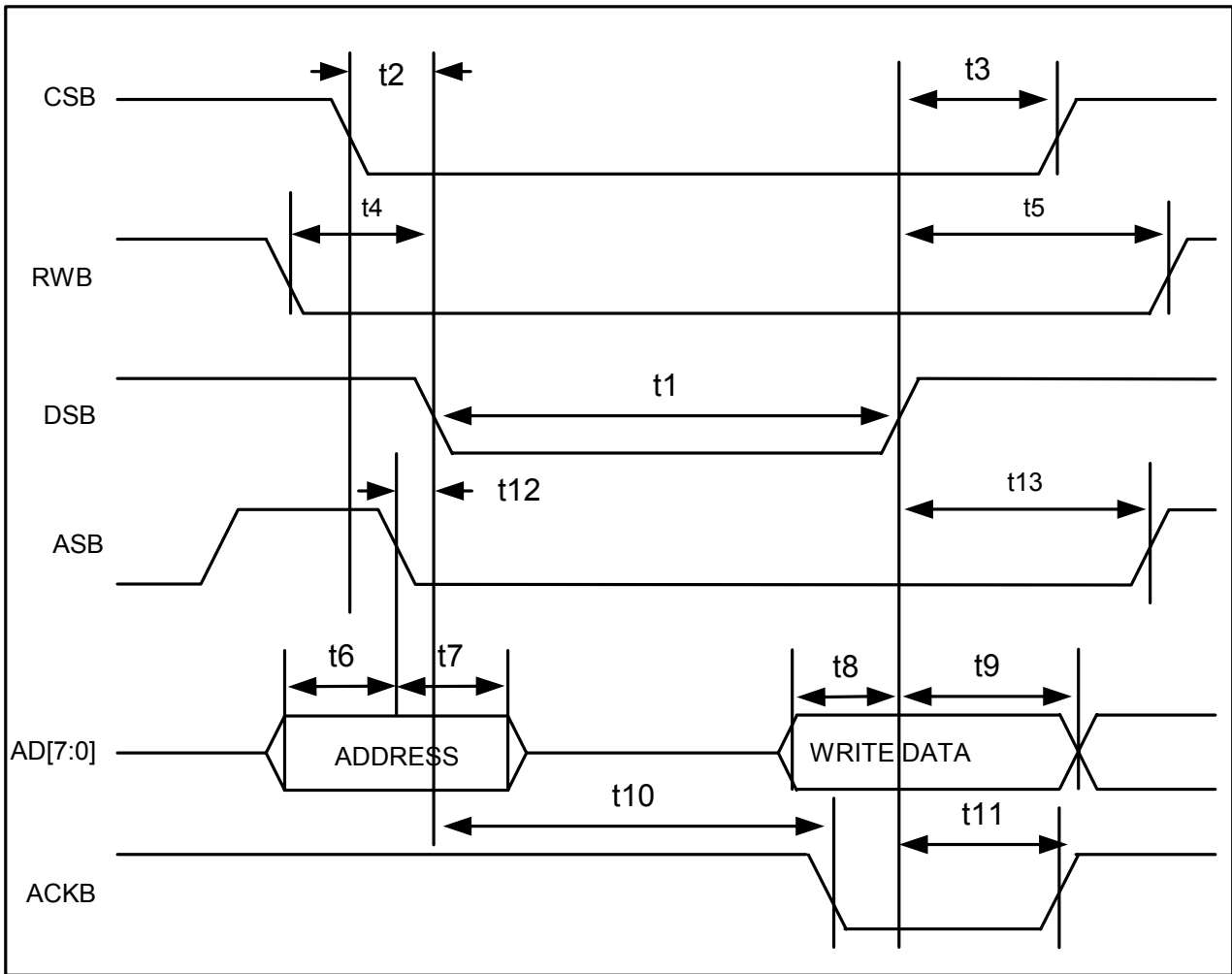

Figure 10-8. Motorola Mux Write Cycle



10.3 Serial Port

Table 10-7. Serial Port Timing Characteristics

([Figure 10-9](#), [Figure 10-10](#), and [Figure 10-11](#))

PARAMETER	SYMBOL	CONDITIONS	MIN	TYP	MAX	UNITS
SCLK High Time	t1		25			ns
SCLK Low Time	t2		25			ns
Active CSB to SCLK Setup Time	t3		50			ns
Last SCLK to CSB Inactive Time	t4		50			ns
CSB Idle Time	t5		50			ns
SDI to SCLK Setup Time	t6		5			ns
SCLK to SDI Hold Time	t7		5			ns
SCLK Falling Edge to SDO High Impedance (CLKE = 0); CSB Rising to SDO High Impedance (CLKE = 1)	t8			100		ns

Figure 10-9. Serial Bus Timing Write Operation

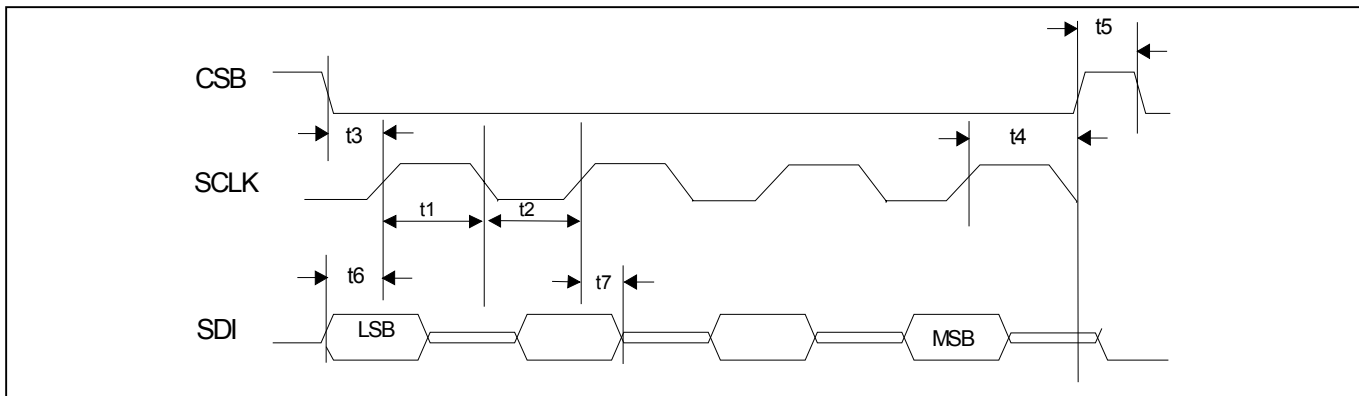

Figure 10-10. Serial Bus Timing Read Operation with CLKE = 0

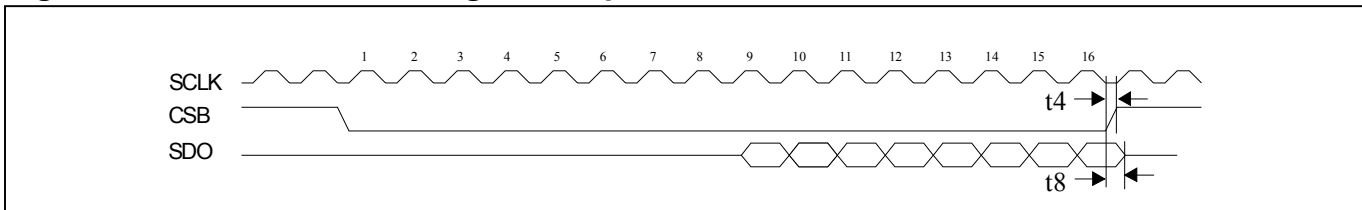
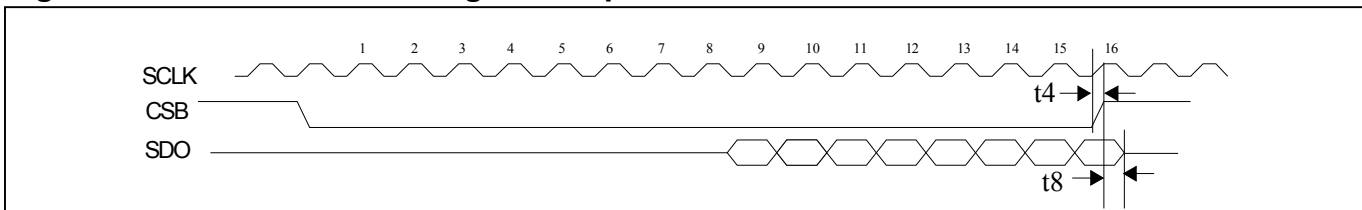

Figure 10-11. Serial Bus Timing Read Operation with CLKE = 1



10.4 System Timing

Table 10-8. Transmitter System Timing

(Figure 10-12)

PARAMETER	SYMBOL	CONDITIONS	MIN	TYP	MAX	UNITS
TPOS, TNEG Setup Time with Respect to TCLK Falling Edge	t1		40			ns
TPOS, TNEG Hold Time with Respect to TCLK Falling Edge	t2		40			ns
TCLK Pulse-Width High	t3		75			ns
TCLK Pulse-Width Low	t4		75			ns
TCLK Period	t5			488		ns
				648		
TCLK Rise Time	t6				25	ns
TCLK Fall Time	t7				25	ns

Figure 10-12. Transmitter Systems Timing

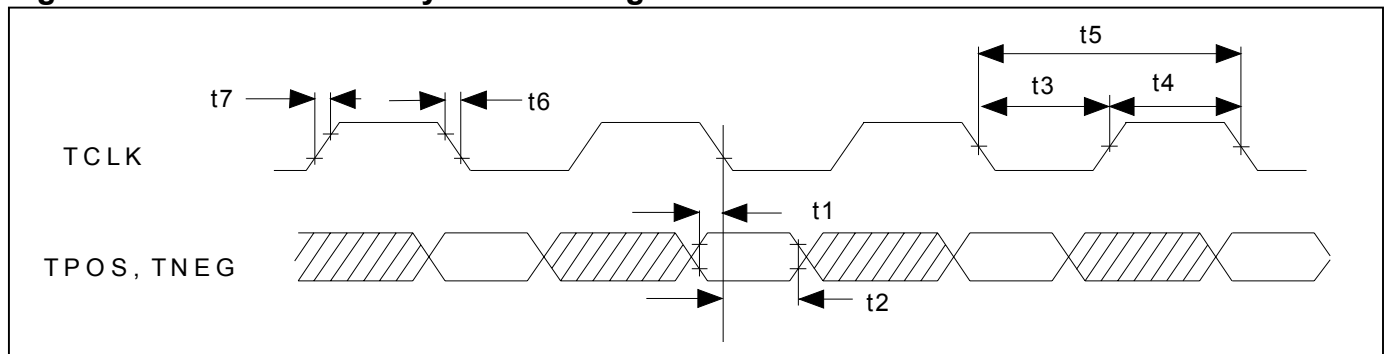
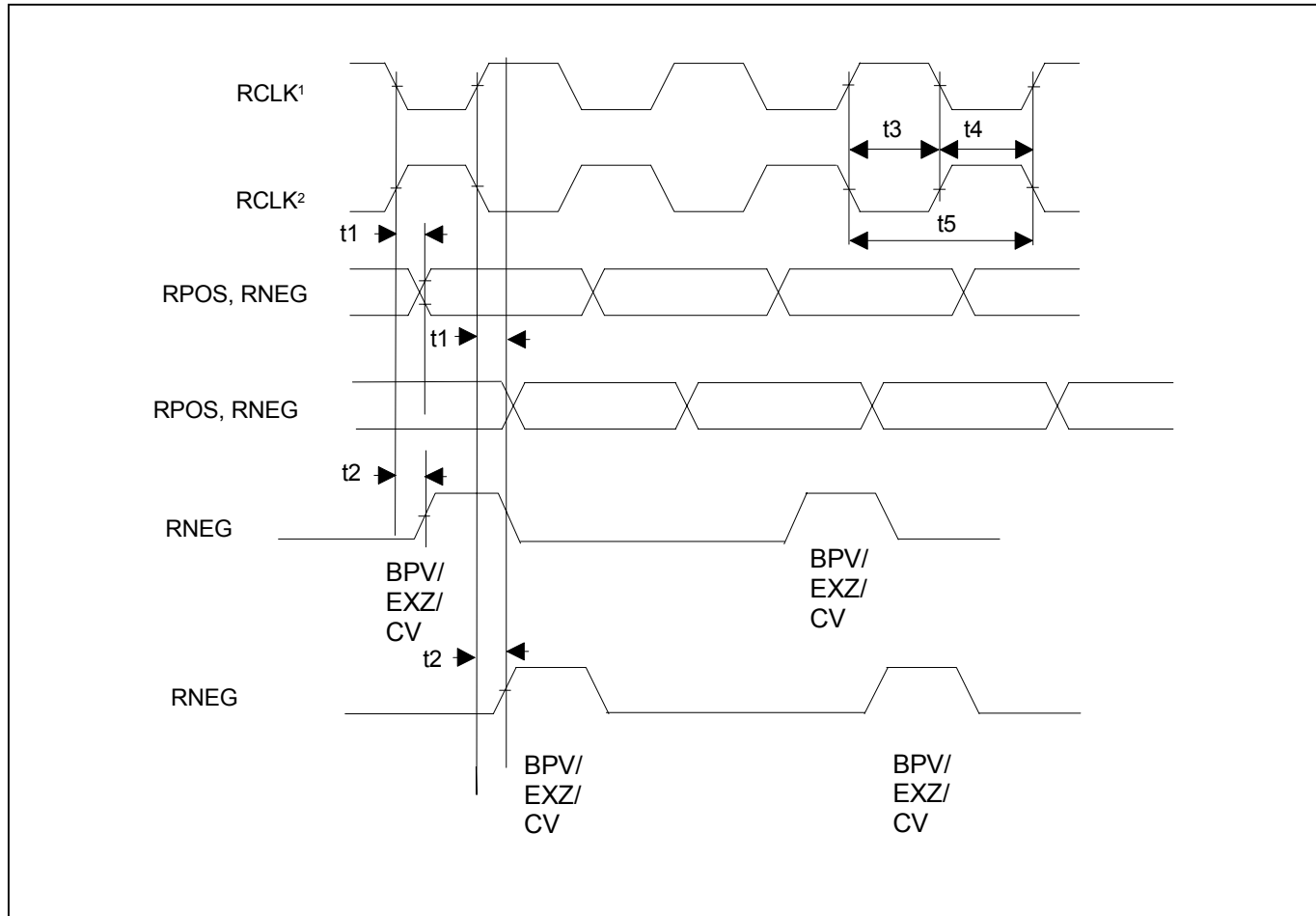

Table 10-9. Receiver System Timing

(Figure 10-13)

PARAMETER	SYMBOL	CONDITIONS	MIN	TYP	MAX	UNITS
Delay RCLK to RPOS, RNEG Valid	t1				50	ns
Delay RCLK to RNEG Valid in Single-Polarity Mode	t2				50	ns
RCLK Pulse-Width High	t3		75			ns
RCLK Pulse-Width Low	t4		75			ns
RCLK Period	t5			488		ns
				648		

Figure 10-13. Receiver Systems Timing



10.5 JTAG Timing

Table 10-10. JTAG Timing Characteristics

(Figure 10-14)

PARAMETER	SYMBOL	CONDITIONS	MIN	TYP	MAX	UNITS
JTCLK Period	t1		100			ns
JTMS and JTDI Setup to JTCLK	t2		25			ns
JTMS and JTDI Hold to JTCLK	t3		25			ns
JTCLK to JTDO Hold	t4				50	ns

Figure 10-14. JTAG Timing

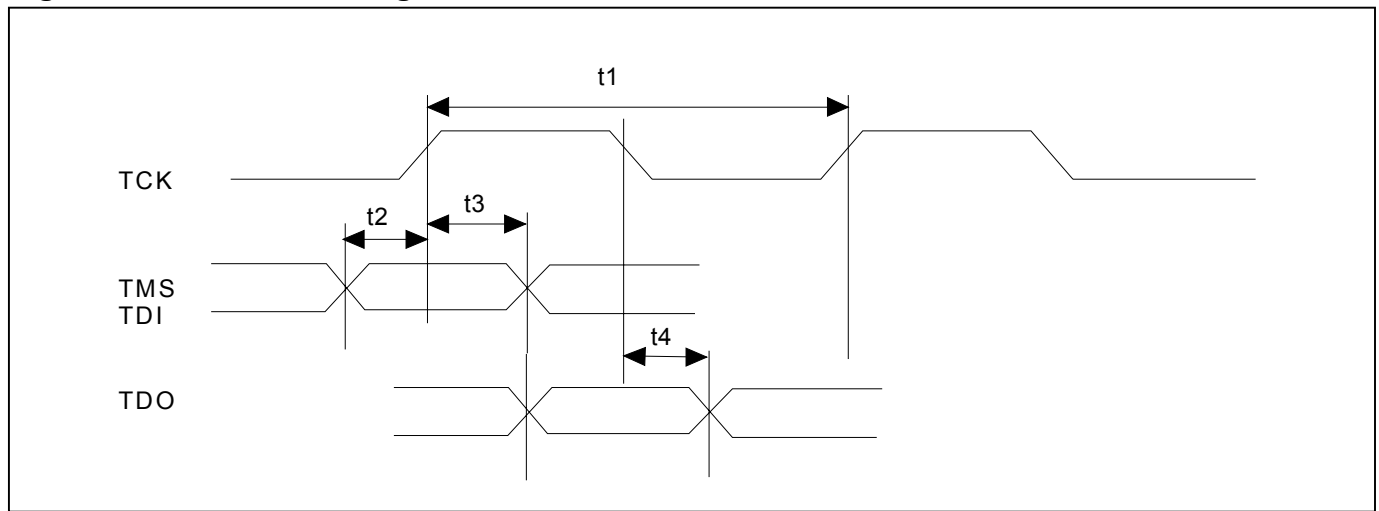

11 PACKAGE INFORMATION

(The package drawing(s) in this data sheet may not reflect the most current specifications. For the latest package outline information, go to www.maxim-ic.com/DallasPackInfo.)

11.1 eLQFP Package Outline (1 of 2)

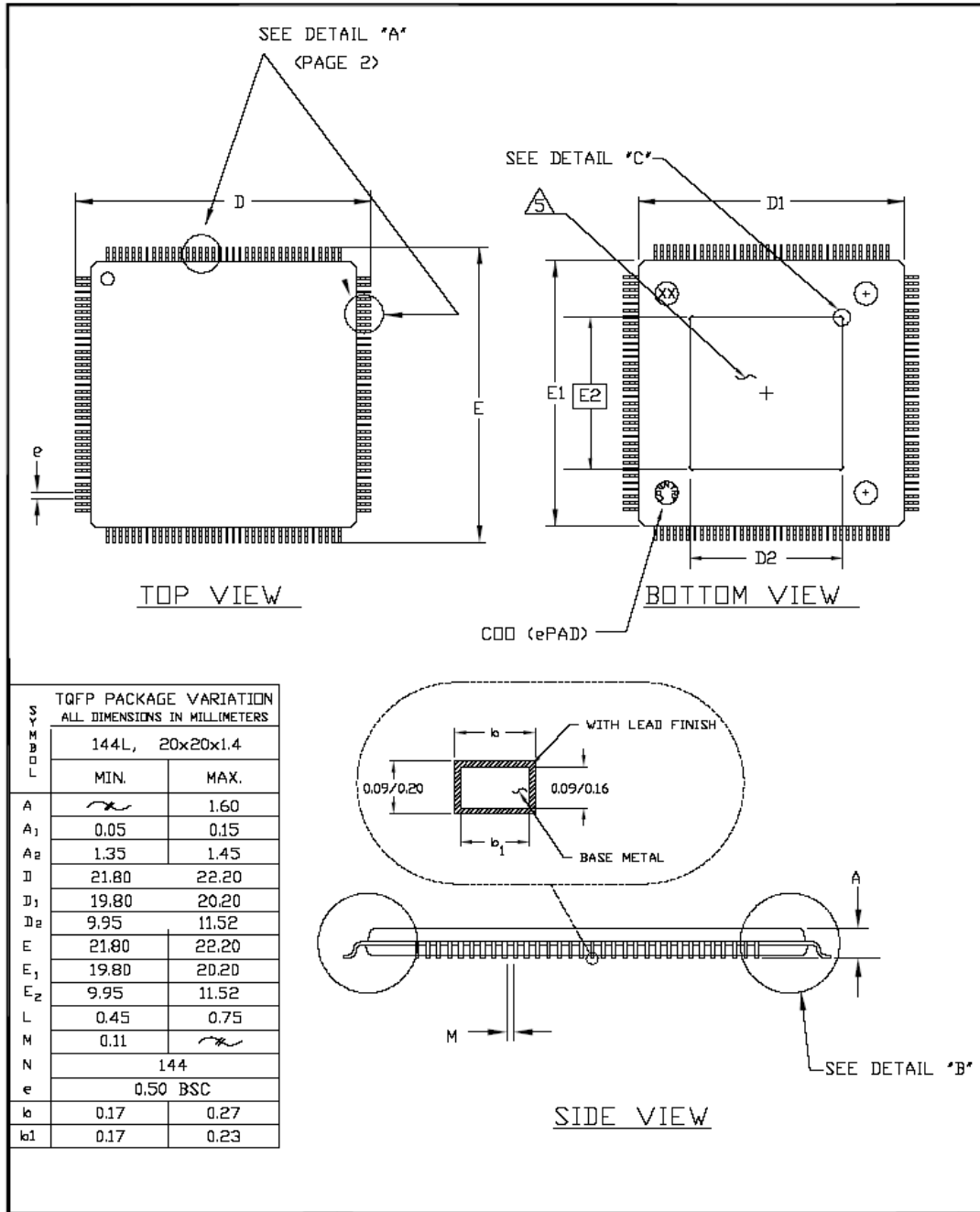

11.2 eLQFP Package Outline (2 of 2)

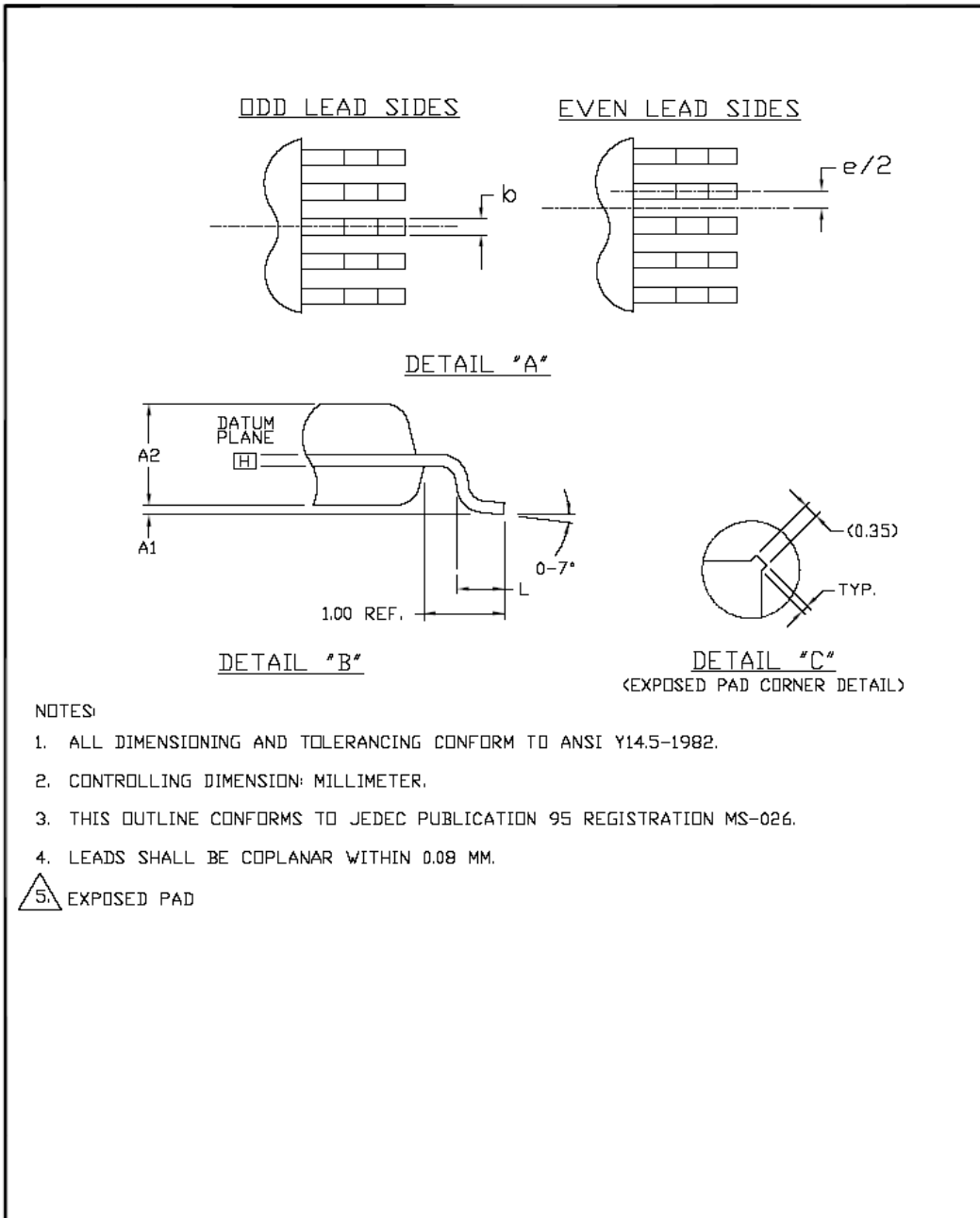

12 DOCUMENT REVISION HISTORY

REVISION	DESCRIPTION
072205	New product release.