

DRV870xD-Q1 Automotive Half-Bridge Gate Driver

1 Features

- AEC-Q100 Qualified for Automotive Applications
 - Device Temperature Grade 1: –40°C to +125°C Ambient Operating Temperature
- Single Half-Bridge Gate Driver
 - Drives Two External N-Channel MOSFETs
 - Supports 100% PWM Duty Cycle
- 5.5- to 45-V Operating Supply-Voltage Range
- PWM Control Interface
- Serial Interface for Configuration (DRV8703D-Q1)
- Adjustable Gate Drive For Slew-Rate Control
- Supports 1.8-V, 3.3-V, and 5-V logic inputs
- Current-Shunt Amplifier
- Integrated PWM Current Regulation
- Low-Power Sleep Mode
- Small Package and Footprint
 - 32-Pin VQFN
 - 5 mm × 5 mm
 - Wettable Flanks Package
- Protection Features
 - Supply Undervoltage Lockout (UVLO)
 - Charge-Pump Undervoltage (CPUV) Lockout
 - Overcurrent Protection (OCP)
 - Gate-Driver Fault (GDF)
 - Thermal Shutdown (TSD)
 - Watchdog Timer (DRV8703D-Q1)
 - Fault-Condition Output (nFAULT)

2 Applications

- Fuel Pumps
- Unidirectional Brushed DC Motors
- Relays or Solenoids
- Unipolar Loads

3 Description

The DRV870xD-Q1 family of devices is a half-bridge gate driver that uses two external N-channel MOSFETs targeted to drive unidirectional brushed-DC motors or solenoid loads.

The PWM interface allows simple interfacing to controller circuits. An internal sense amplifier provides adjustable current control. The gate driver includes circuitry to regulate the winding current using fixed off-time PWM current chopping.

The DRV870xD-Q1 family of devices drives both high-side and low-side FETs with a 10.5-V V_{GS} gate drive. The gate-drive current for all external FETs is configurable with a single external resistor or through the serial peripheral interface (SPI).

A low-power sleep mode is provided which shuts down internal circuitry to achieve a very-low quiescent-current draw.

Device Information⁽¹⁾

| PART NUMBER | PACKAGE | BODY SIZE (NOM) |
|-------------|-----------|-------------------|
| DRV8702D-Q1 | VQFN (32) | 5.00 mm × 5.00 mm |
| DRV8703D-Q1 | | |

(1) For all available packages, see the orderable addendum at the end of the data sheet.

Simplified Schematic

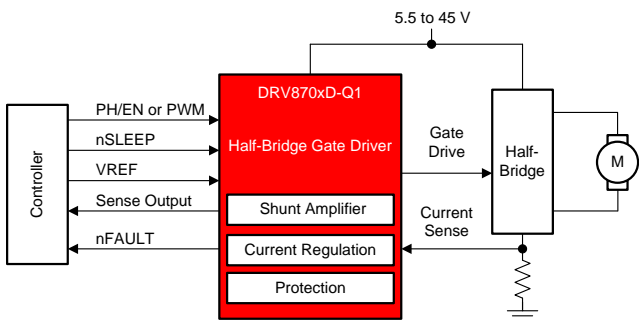

Copyright © 2017, Texas Instruments Incorporated

Gate-Drive Current

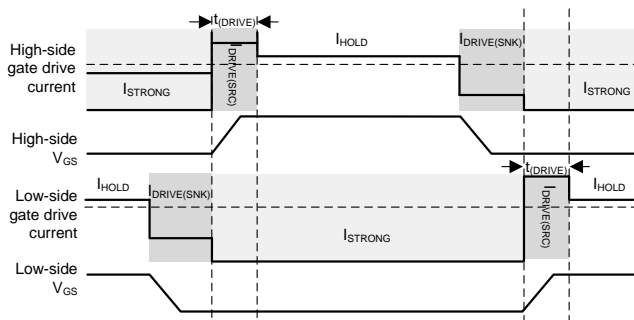

Table of Contents

| | | | |
|------------------------------------------------|-----------|------------------------------------------------------|-----------|
| 1 Features | 1 | 7.6 Register Maps | 41 |
| 2 Applications | 1 | 8 Application and Implementation | 47 |
| 3 Description | 1 | 8.1 Application Information..... | 47 |
| 4 Revision History | 2 | 8.2 Typical Application | 47 |
| 5 Pin Configuration and Functions | 3 | 9 Power Supply Recommendations | 51 |
| 6 Specifications | 5 | 9.1 Bulk Capacitance Sizing | 51 |
| 6.1 Absolute Maximum Ratings | 5 | 10 Layout | 52 |
| 6.2 ESD Ratings..... | 5 | 10.1 Layout Guidelines | 52 |
| 6.3 Recommended Operating Conditions..... | 6 | 10.2 Layout Example | 52 |
| 6.4 Thermal Information | 6 | 11 Device and Documentation Support | 53 |
| 6.5 Electrical Characteristics..... | 6 | 11.1 Documentation Support | 53 |
| 6.6 SPI Timing Requirements | 11 | 11.2 Related Links | 53 |
| 6.7 Switching Characteristics | 11 | 11.3 Receiving Notification of Documentation Updates | 53 |
| 6.8 Typical Characteristics | 13 | 11.4 Community Resources..... | 53 |
| 7 Detailed Description | 18 | 11.5 Trademarks | 53 |
| 7.1 Overview | 18 | 11.6 Electrostatic Discharge Caution..... | 53 |
| 7.2 Functional Block Diagram | 19 | 11.7 Glossary | 53 |
| 7.3 Feature Description..... | 21 | 12 Mechanical, Packaging, and Orderable | 54 |
| 7.4 Device Functional Modes..... | 39 | Information | 54 |
| 7.5 Programming..... | 39 | 12.1 Package Option Addendum | 58 |

4 Revision History

NOTE: Page numbers for previous revisions may differ from page numbers in the current version.

| DATE | REVISION | NOTES |
|------------|----------|------------------|
| March 2017 | * | Initial release. |

5 Pin Configuration and Functions

DRV8702D-Q1 RHB Package With Wettable Flanks
32-Pin VQFN
Top View

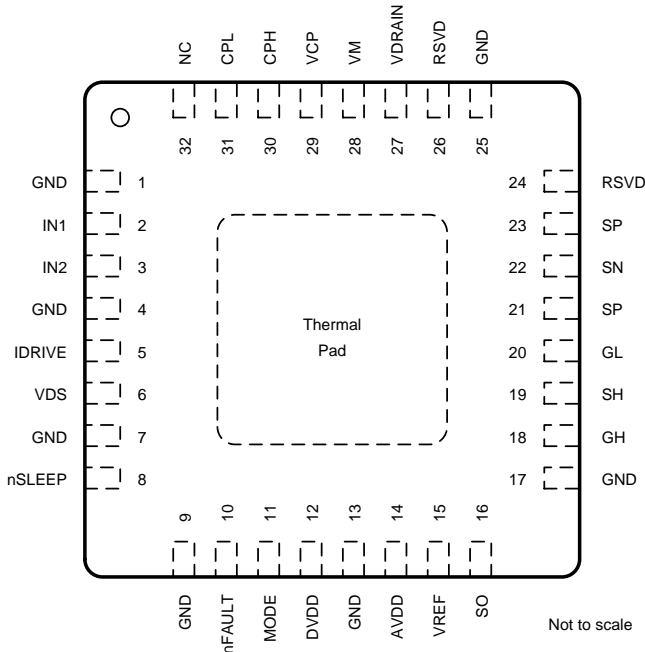

DRV8703D-Q1 RHB Package With Wettable Flanks
32-Pin VQFN
Top View

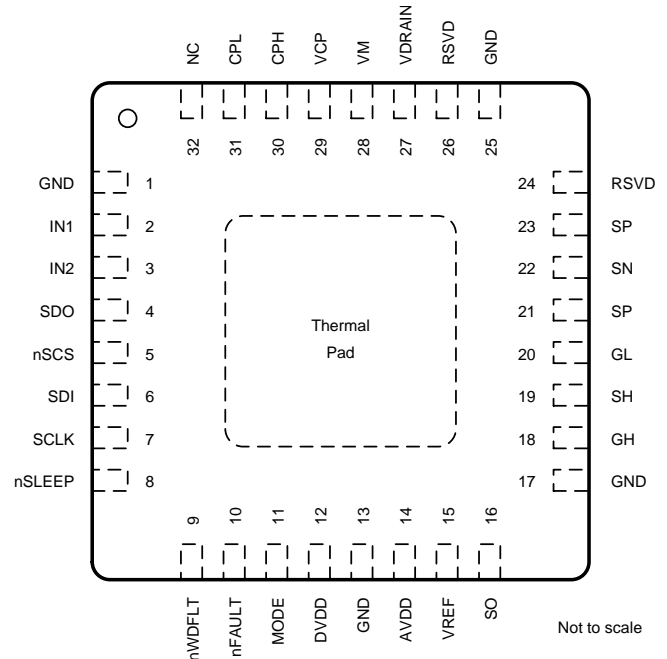

Pin Functions

| NAME | PIN NO. | | TYPE ⁽¹⁾ | DESCRIPTION |
|--------|-------------|-------------|---------------------|--------------------------------------------------------------------------------------------------------------------------------------------------------------------------------------------------|
| | DRV8702D-Q1 | DRV8703D-Q1 | | |
| AVDD | 14 | 14 | PWR | Analog regulator. This pin is the 5-V analog supply regulator. Bypass this pin to ground with a 6.3-V, 1- μ F ceramic capacitor. |
| CPH | 30 | 30 | PWR | Charge-pump switching node. Connect a 0.1- μ F X7R capacitor rated for the supply voltage (VM) between the CPH and CPL pins. |
| CPL | 31 | 31 | PWR | Charge-pump switching node. Connect a 0.1- μ F X7R capacitor rated for the supply voltage (VM) between the CPH and CPL pins. |
| DVDD | 12 | 12 | PWR | Logic regulator. This pin is the regulator for the 3.3-V logic supply. Bypass this pin to ground with a 6.3-V, 1- μ F ceramic capacitor. |
| GH | 18 | 18 | O | High-side gate. Connect this pin to the high-side FET gate. |
| GL | 20 | 20 | O | Low-side gate. Connect this pin to the low-side FET gate. |
| GND | 1 | 1 | PWR | Device ground. Connect this pin to the system ground. |
| GND | 13 | 13 | PWR | Device ground. Connect this pin to the system ground. |
| GND | 17 | 17 | PWR | Device ground. Connect this pin to the system ground. |
| GND | 25 | 25 | PWR | Device ground. Connect this pin to the system ground. |
| GND | 4 | — | PWR | Device ground. Connect this pin to the system ground. |
| GND | 7 | — | PWR | Device ground. Connect this pin to the system ground. |
| GND | 9 | — | PWR | Device ground. Connect this pin to the system ground. |
| IDRIVE | 5 | — | I | Current setting pin for the gate drive. The resistor value or voltage forced on this pin sets the gate-drive current. For more information see the IDRIVE Configuration section. |
| IN1 | 2 | 2 | I | Input control pins. The logic of this pin is dependent on the MODE pin. |
| IN2 | 3 | 3 | I | Input control pins. The logic of this pin is dependent on the MODE pin. |

(1) I = input, O = output, PWR = power, NC = no connect, OD = open-drain output

Pin Functions (continued)

| NAME | PIN | | TYPE ⁽¹⁾ | DESCRIPTION |
|--------|-------------|-------------|---------------------|--------------------------------------------------------------------------------------------------------------------------------------------------------------------------------------------------------------------------------------------------------------------------------|
| | NO. | | | |
| | DRV8702D-Q1 | DRV8703D-Q1 | | |
| MODE | 11 | 11 | I | Mode control pin. Pull this pin to logic high for half-bridge operation without internal current regulation. Leave this pin as no-connect for half-bridge operation with internal current regulation. Operation of this pin is latched on power up or when exiting sleep mode. |
| NC | 32 | 32 | NC | No connect. No internal connection |
| nFAULT | 10 | 10 | OD | Fault indication pin. This pin is pulled logic low when a fault condition occurs. This pin is an open-drain output that requires an external pullup resistor. |
| nSCS | — | 5 | I | SPI chip select. This pin is the select and enable for SPI. This pin is active low. |
| nSLEEP | 8 | 8 | I | Device sleep mode. Pull this pin to logic low to put device into a low-power sleep mode with the FETs in high impedance (Hi-Z). This pin is connected to an internal pulldown resistor. |
| nWDFLT | — | 9 | OD | Watchdog fault indication pin. This pin is pulled logic low when a watchdog fault condition occurs. This pin is an open-drain output that requires an external pullup resistor. |
| RSVD | 26 | 26 | RSVD | Reserved. Do not connect anything. |
| RSVD | 24 | 24 | RSVD | Reserved. Do not connect anything. |
| SCLK | — | 7 | I | SPI clock. This pin is for the SPI clock signal. |
| SDI | — | 6 | I | SPI input. This pin is for the SPI input signal. |
| SDO | — | 4 | OD | SPI output. This pin is for the SPI output signal. This pin is an open-drain output that requires an external pullup resistor. |
| SH | 19 | 19 | I | High-side source. Connect this pin to the high-side FET source. |
| SN | 22 | 22 | I | Shunt-amplifier negative input. Connect this pin to the current-sense resistor. |
| SO | 16 | 16 | O | Shunt-amplifier output. The voltage on this pin is equal to the SP voltage times A_V plus an offset. Place no more than 1 nF of capacitance on this pin. |
| SP | 21 | 21 | I | Shunt-amplifier positive input. Connect this pin to the current-sense resistor. |
| SP | 23 | 23 | I | Shunt-amplifier positive input. Connect this pin to the current-sense resistor. |
| VCP | 29 | 29 | PWR | Charge-pump output. Connect a 16-V, 1- μ F ceramic capacitor between this pin and the VM pin. |
| VDRAIN | 27 | 27 | I | High-side FET drain connection. This pin is common for the half-bridge. |
| VDS | 6 | — | I | VDS monitor setting pin. The resistor value or voltage forced on this pin sets the VDS monitor threshold. For more information see the VDS Configuration section. |
| VM | 28 | 28 | PWR | Power supply. Connect this pin to the motor supply voltage. Bypass this pin to ground with a 0.1- μ F ceramic plus a 10- μ F (minimum) capacitor. |
| VREF | 15 | 15 | I | Current set reference input. The voltage on this pin sets the driver chopping current. |

6 Specifications

6.1 Absolute Maximum Ratings

over operating free-air temperature range (unless otherwise noted)⁽¹⁾

| | | MIN | MAX | UNIT |
|--------------------------------------------------------------|----------------------------------------------------------------------------------|------|-----------------------|------|
| Power supply voltage | VM | -0.3 | 47 | V |
| Charge pump voltage | VCP, CPH | -0.3 | V _{VM} + 12 | V |
| Charge pump negative switching pin | CPL | -0.3 | V _{VM} | V |
| Internal logic regulator voltage | DVDD | -0.3 | 3.8 | V |
| Internal analog regulator voltage | AVDD | -0.3 | 5.75 | V |
| Drain pin voltage | VDRAIN | -0.3 | 47 | V |
| Voltage difference between supply and VDRAIN | VM – VDRAIN | -10 | 10 | V |
| Control pin voltage | IN1, IN2, nSLEEP, nFAULT, VREF, IDRIVE, VVDS, MODE, nSCS, SCLK, SDI, SDO, nWDFLT | -0.3 | 5.75 | V |
| High-side gate pin voltage | GH | -0.3 | V _{VM} + 12 | V |
| Low-side gate pin voltage | GL | -0.3 | 12 | V |
| Continuous phase-node pin voltage | SH | -1.2 | V _{VM} + 1.2 | V |
| Pulsed 10-μs phase-node pin voltage | SH | -2 | V _{VM} + 2 | V |
| Continuous shunt amplifier input pin voltage | SP | -0.5 | 1 | V |
| | SN | -0.3 | 0.3 | V |
| Pulsed 10-μs shunt amplifier input pin voltage | SP | -1 | 1 | V |
| Shunt amplifier output pin voltage | SO | -0.3 | 5.75 | V |
| Shunt amplifier output pin current | SO | 0 | 5 | mA |
| Maximum current, limit current with external series resistor | VDRAIN | -2 | 2 | mA |
| Open-drain output current | nFAULT, SDO, nWDFLT | 0 | 10 | mA |
| Gate pin source current | GH, GL | 0 | 250 | mA |
| Gate pin sink current | GH, GL | 0 | 500 | mA |
| Operating junction temperature, T _J | | -40 | 150 | °C |
| Storage temperature, T _{stg} | | -65 | 150 | °C |

(1) Stresses beyond those listed under *Absolute Maximum Ratings* may cause permanent damage to the device. These are stress ratings only, which do not imply functional operation of the device at these or any other conditions beyond those indicated under *Recommended Operating Conditions*. Exposure to absolute-maximum-rated conditions for extended periods may affect device reliability.

6.2 ESD Ratings

| | | VALUE | UNIT | |
|--------------------|-------------------------|---------------------------------------------------------|-----------------------------------------------|------|
| V _(ESD) | Electrostatic discharge | Human-body model (HBM), per AEC Q100-002 ⁽¹⁾ | | |
| | | Charged-device model (CDM), per AEC Q100-011 | All pins | ±500 |
| | | | Corner pins (1, 8, 9, 16, 17, 24, 25, and 32) | ±750 |

(1) AEC Q100-002 indicates that HBM stressing shall be in accordance with the ANSI/ESDA/JEDEC JS-001 specification.

6.3 Recommended Operating Conditions

| | | | MIN | MAX | UNIT |
|--------------------|------------------------------------------|----------|--------------------|-------------------|------|
| V _{VM} | Power supply voltage | VM | 5.5 | 45 | V |
| V _{CC} | Logic-level input voltage | | 0 | 5.25 | V |
| V _{VREF} | Reference root-mean-square (rms) voltage | VREF | 0.3 ⁽¹⁾ | 3.6 | V |
| f _(PWM) | Applied PWM signal (IN1/IN2) | IN1, IN2 | | 100 | kHz |
| I _{AVDD} | AVDD external load current | | | 30 ⁽²⁾ | mA |
| I _{DVDD} | DVDD external load current | | | 30 ⁽²⁾ | mA |
| I _{SO} | Shunt-amplifier output-current loading | SO | | 5 | mA |
| T _A | Operating ambient temperature | | -40 | 125 | °C |

(1) Operational at V_{VREF} = 0 to approximately 0.3 V, but accuracy is degraded.

(2) Power dissipation and thermal limits must be observed.

6.4 Thermal Information

| THERMAL METRIC ⁽¹⁾ | | DRV870xD-Q1 | | UNIT |
|-------------------------------|----------------------------------------------|-------------|--|------|
| | | RHB (VQFN) | | |
| | | 32 PINS | | |
| R _{θJA} | Junction-to-ambient thermal resistance | 32.9 | | °C/W |
| R _{θJC(top)} | Junction-to-case (top) thermal resistance | 19.6 | | °C/W |
| R _{θJB} | Junction-to-board thermal resistance | 6.8 | | °C/W |
| ψ _{JT} | Junction-to-top characterization parameter | 0.3 | | °C/W |
| ψ _{JB} | Junction-to-board characterization parameter | 6.8 | | °C/W |
| R _{θJC(bot)} | Junction-to-case (bottom) thermal resistance | 1.8 | | °C/W |

(1) For more information about traditional and new thermal metrics, see the [Semiconductor and IC Package Thermal Metrics](#) application report.

6.5 Electrical Characteristics

Over recommended operating conditions unless otherwise noted. Typical limits apply for T_A = 25°C and V_{VM} = 13.5 V

| PARAMETER | | TEST CONDITIONS | MIN | TYP | MAX | UNIT |
|-----------------------------------------------------------------|----------------------------------|-----------------------------------------------------------------------------|------|------|------|------|
| POWER SUPPLIES (VM, AVDD, DVDD) | | | | | | |
| V _{VM} | VM operating voltage | Gate drivers functional | 5.5 | | 45 | V |
| | | Logic functional | 4.5 | | 45 | |
| I _{VM} | VM operating supply current | V _{VM} = 13.5 V; nSLEEP=1 | 5.5 | 7.5 | 12 | mA |
| I _(SLEEP) | VM sleep mode supply current | nSLEEP = 0, V _{VM} = 13.5 V, T _A = 25°C | | | 14 | μA |
| | | nSLEEP = 0, V _{VM} = 13.5 V, T _A = 125°C ⁽¹⁾ | | | 25 | |
| V _{DVDD} | Internal logic regulator voltage | 2-mA load | 3 | 3.3 | 3.5 | V |
| | | 30-mA load, V _{VM} = 13.5 V | 2.9 | 3.2 | 3.5 | |
| V _{AVDD} | Internal logic regulator voltage | 2-mA load | 4.7 | 5 | 5.3 | V |
| | | 30-mA load, V _{VM} = 13.5 V | 4.6 | 5 | 5.3 | |
| CHARGE PUMP (VCP, CPH, CPL) | | | | | | |
| V _{VCP} | VCP operating voltage | V _{VM} = 13.5 V; I _{VCP} = 0 to 12 mA | 22.5 | 23.5 | 24.5 | V |
| | | V _{VM} = 8 V; I _{VCP} = 0 to 10 mA | 13.7 | 14 | 14.8 | |
| | | V _{VM} = 5.5 V; I _{VCP} = 0 to 8 mA | 8.9 | 9.1 | 9.5 | |
| I _{VCP} | Charge-pump current capacity | V _{VM} > 13.5 V | 12 | | | mA |
| | | 8 V < V _{VM} < 13.5 V | 10 | | | |
| | | 5.5 V < V _{VM} < 8 V | 8 | | | |
| CONTROL INPUTS (IN1, IN2, nSLEEP, MODE, nSCS, SCLK, SDI) | | | | | | |
| V _{IL} | Input logic-low voltage | | 0 | | 0.8 | V |
| V _{IH} | Input logic-high voltage | | 1.5 | | 5.25 | V |

(1) Ensured by design and characterization data.

Electrical Characteristics (continued)

Over recommended operating conditions unless otherwise noted. Typical limits apply for $T_A = 25^\circ\text{C}$ and $V_{VM} = 13.5\text{ V}$

| PARAMETER | | TEST CONDITIONS | MIN | TYP | MAX | UNIT |
|----------------------------------------------|----------------------------------------------------------|-------------------------------------------------------------------------------------|-----|--------------|------|------------------|
| V_{hys} | Input logic hysteresis | | 100 | | | mV |
| I_{IL} | Input logic-low current | $V_{IN} = 0\text{ V}$ | -5 | | 5 | μA |
| I_{IH} | Input logic-high current | $V_{IN} = 5\text{ V}$ | | | 70 | μA |
| R_{PD} | Pulldown resistance | | 64 | 100 | 173 | $\text{k}\Omega$ |
| CONTROL OUTPUTS (nFAULT, nWDFLT, SDO) | | | | | | |
| V_{OL} | Output logic-low voltage | $I_O = 2\text{ mA}$ | | | 0.1 | V |
| I_{OZ} | Output high-impedance leakage | 5V pullup voltage | -2 | | 2 | μA |
| FET GATE DRIVERS (GH, SH, GL) | | | | | | |
| V_{GSH} | High-side V_{GS} gate drive (gate-to-source) | $V_{VM} > 13.5\text{ V}$; V_{GSH} with respect to SH | | 10.5 | 11.5 | V |
| | | $V_{VM} = 8\text{ V}$; V_{GSH} with respect to SH | | 5.7 | 6.8 | |
| | | $V_{VM} = 5.5\text{ V}$; V_{GSH} with respect to SH | | 3.4 | 4 | |
| V_{GSL} | Low-side V_{GS} gate drive (gate-to-source) | $V_{VM} > 10.5\text{ V}$ | | 10.5 | | V |
| | | $V_{VM} < 10.5\text{ V}$ | | $V_{VM} - 2$ | | |
| $I_{DRIVE(SRC_HS)}$ | High-side peak source current ($V_{VM} = 5.5\text{V}$) | $R_{(IDRIVE)} < 1\text{ k}\Omega$ to GND (DRV8702D) or IDRIVE = 3'b000 (DRV8703D) | | 10 | | mA |
| | | $R_{(IDRIVE)} = 33\text{ k}\Omega$ to GND (DRV8702D) or IDRIVE = 3'b001 (DRV8703D) | | 20 | | |
| | | $R_{(IDRIVE)} = 200\text{ k}\Omega$ to GND (DRV8702D) or IDRIVE = 3'b010 (DRV8703D) | | 50 | | |
| | | IDRIVE = 3'b011 (DRV8703D) | | 70 | | |
| | | IDRIVE = 3'b100 (DRV8703D) | | 100 | | |
| | | $R_{(IDRIVE)} > 2\text{ M}\Omega$ to GND (DRV8702D) or IDRIVE = 3'b101 (DRV8703D) | | 145 | | |
| | | $R_{(IDRIVE)} = 68\text{ k}\Omega$ to AVDD (DRV8702D) or IDRIVE = 3'b110 (DRV8703D) | | 190 | | |
| | | $R_{(IDRIVE)} = 1\text{ k}\Omega$ to AVDD (DRV8702D) or IDRIVE = 3'b111 (DRV8703D) | | 240 | | |
| $I_{DRIVE(SNK_HS)}$ | High-side peak sink current ($V_{VM} = 5.5\text{V}$) | $R_{(IDRIVE)} < 1\text{ k}\Omega$ to GND (DRV8702D) or IDRIVE = 3'b000 (DRV8703D) | | 20 | | mA |
| | | $R_{(IDRIVE)} = 33\text{ k}\Omega$ to GND (DRV8702D) or IDRIVE = 3'b001 (DRV8703D) | | 40 | | |
| | | $R_{(IDRIVE)} = 200\text{ k}\Omega$ to GND (DRV8702D) or IDRIVE = 3'b010 (DRV8703D) | | 90 | | |
| | | IDRIVE = 3'b011 (DRV8703D) | | 120 | | |
| | | IDRIVE = 3'b100 (DRV8703D) | | 170 | | |
| | | $R_{(IDRIVE)} > 2\text{ M}\Omega$ to GND (DRV8702D) or IDRIVE = 3'b101 (DRV8703D) | | 250 | | |
| | | $R_{(IDRIVE)} = 68\text{ k}\Omega$ to AVDD (DRV8702D) or IDRIVE = 3'b110 (DRV8703D) | | 330 | | |
| | | $R_{(IDRIVE)} = 1\text{ k}\Omega$ to AVDD (DRV8702D) or IDRIVE = 3'b111 (DRV8703D) | | 420 | | |

Electrical Characteristics (continued)

 Over recommended operating conditions unless otherwise noted. Typical limits apply for $T_A = 25^\circ\text{C}$ and $V_{VM} = 13.5\text{ V}$

| PARAMETER | TEST CONDITIONS | MIN | TYP | MAX | UNIT |
|----------------------------------------------------------------------------------------------|--------------------------------------------------------------------------------------------|-----|-----|-----|------|
| $I_{\text{DRIVE}(\text{SRC_LS})}$ Low-side peak source current ($V_{VM} = 5.5\text{V}$) | $R_{(\text{IDRIVE})} < 1\text{ k}\Omega$ to GND (DRV8702D) or IDRIVE = 3'b000 (DRV8703D) | | 10 | | mA |
| | $R_{(\text{IDRIVE})} = 33\text{ k}\Omega$ to GND (DRV8702D) or IDRIVE = 3'b001 (DRV8703D) | | 20 | | |
| | $R_{(\text{IDRIVE})} = 200\text{ k}\Omega$ to GND (DRV8702D) or IDRIVE = 3'b010 (DRV8703D) | | 40 | | |
| | IDRIVE = 3'b011 (DRV8703D) | | 55 | | |
| | IDRIVE = 3'b100 (DRV8703D) | | 75 | | |
| | $R_{(\text{IDRIVE})} > 2\text{ M}\Omega$ to GND (DRV8702D) or IDRIVE = 3'b101 (DRV8703D) | | 115 | | |
| | $R_{(\text{IDRIVE})} = 68\text{ k}\Omega$ to AVDD (DRV8702D) or IDRIVE = 3'b110 (DRV8703D) | | 145 | | |
| | $R_{(\text{IDRIVE})} = 1\text{ k}\Omega$ to AVDD (DRV8702D) or IDRIVE = 3'b111 (DRV8703D) | | 190 | | |
| $I_{\text{DRIVE}(\text{SNK_LS})}$ Low-side peak sink current ($V_{VM} = 5.5\text{V}$) | $R_{(\text{IDRIVE})} < 1\text{ k}\Omega$ to GND (DRV8702D) or IDRIVE = 3'b000 (DRV8703D) | | 20 | | mA |
| | $R_{(\text{IDRIVE})} = 33\text{ k}\Omega$ to GND (DRV8702D) or IDRIVE = 3'b001 (DRV8703D) | | 40 | | |
| | $R_{(\text{IDRIVE})} = 200\text{ k}\Omega$ to GND (DRV8702D) or IDRIVE = 3'b010 (DRV8703D) | | 85 | | |
| | IDRIVE = 3'b011 (DRV8703D) | | 115 | | |
| | IDRIVE = 3'b100 (DRV8703D) | | 160 | | |
| | $R_{(\text{IDRIVE})} > 2\text{ M}\Omega$ to GND (DRV8702D) or IDRIVE = 3'b101 (DRV8703D) | | 235 | | |
| | $R_{(\text{IDRIVE})} = 68\text{ k}\Omega$ to AVDD (DRV8702D) or IDRIVE = 3'b110 (DRV8703D) | | 300 | | |
| | $R_{(\text{IDRIVE})} = 1\text{ k}\Omega$ to AVDD (DRV8702D) or IDRIVE = 3'b111 (DRV8703D) | | 360 | | |
| $I_{\text{DRIVE}(\text{SRC_HS})}$ High-side peak source current ($V_{VM} = 13.5\text{V}$) | $R_{(\text{IDRIVE})} < 1\text{ k}\Omega$ to GND (DRV8702D) or IDRIVE = 3'b000 (DRV8703D) | | 10 | | mA |
| | $R_{(\text{IDRIVE})} = 33\text{ k}\Omega$ to GND (DRV8702D) or IDRIVE = 3'b001 (DRV8703D) | | 20 | | |
| | $R_{(\text{IDRIVE})} = 200\text{ k}\Omega$ to GND (DRV8702D) or IDRIVE = 3'b010 (DRV8703D) | | 50 | | |
| | IDRIVE = 3'b011 (DRV8703D) | | 70 | | |
| | IDRIVE = 3'b100 (DRV8703D) | | 105 | | |
| | $R_{(\text{IDRIVE})} > 2\text{ M}\Omega$ to GND (DRV8702D) or IDRIVE = 3'b101 (DRV8703D) | | 155 | | |
| | $R_{(\text{IDRIVE})} = 68\text{ k}\Omega$ to AVDD (DRV8702D) or IDRIVE = 3'b110 (DRV8703D) | | 210 | | |
| | $R_{(\text{IDRIVE})} = 1\text{ k}\Omega$ to AVDD (DRV8702D) or IDRIVE = 3'b111 (DRV8703D) | | 260 | | |

Electrical Characteristics (continued)

Over recommended operating conditions unless otherwise noted. Typical limits apply for $T_A = 25^\circ\text{C}$ and $V_{VM} = 13.5\text{ V}$

| PARAMETER | TEST CONDITIONS | MIN | TYP | MAX | UNIT |
|-------------------------------------------------------------------------------------|--------------------------------------------------------------------------------------------|-----|--------------------|-----|------------|
| $I_{\text{DRIVE(SNK_HS)}}$ High-side peak sink current ($V_{VM} = 13.5\text{V}$) | $R_{(\text{IDRIVE})} < 1\text{ k}\Omega$ to GND (DRV8702D) or IDRIVE = 3'b000 (DRV8703D) | | 20 | | mA |
| | $R_{(\text{IDRIVE})} = 33\text{ k}\Omega$ to GND (DRV8702D) or IDRIVE = 3'b001 (DRV8703D) | | 40 | | |
| | $R_{(\text{IDRIVE})} = 200\text{ k}\Omega$ to GND (DRV8702D) or IDRIVE = 3'b010 (DRV8703D) | | 95 | | |
| | IDRIVE = 3'b011 (DRV8703D) | | 130 | | |
| | IDRIVE = 3'b100 (DRV8703D) | | 185 | | |
| | $R_{(\text{IDRIVE})} > 2\text{ M}\Omega$ to GND (DRV8702D) or IDRIVE = 3'b101 (DRV8703D) | | 265 | | |
| | $R_{(\text{IDRIVE})} = 68\text{ k}\Omega$ to AVDD (DRV8702D) or IDRIVE = 3'b110 (DRV8703D) | | 350 | | |
| | $R_{(\text{IDRIVE})} = 1\text{ k}\Omega$ to AVDD (DRV8702D) or IDRIVE = 3'b111 (DRV8703D) | | 440 | | |
| $I_{\text{DRIVE(SRC_LS)}}$ Low-side peak source current ($V_{VM} = 13.5\text{V}$) | $R_{(\text{IDRIVE})} < 1\text{ k}\Omega$ to GND (DRV8702D) or IDRIVE = 3'b000 (DRV8703D) | | 10 | | mA |
| | $R_{(\text{IDRIVE})} = 33\text{ k}\Omega$ to GND (DRV8702D) or IDRIVE = 3'b001 (DRV8703D) | | 20 | | |
| | $R_{(\text{IDRIVE})} = 200\text{ k}\Omega$ to GND (DRV8702D) or IDRIVE = 3'b010 (DRV8703D) | | 45 | | |
| | IDRIVE = 3'b011 (DRV8703D) | | 60 | | |
| | IDRIVE = 3'b100 (DRV8703D) | | 90 | | |
| | $R_{(\text{IDRIVE})} > 2\text{ M}\Omega$ to GND (DRV8702D) or IDRIVE = 3'b101 (DRV8703D) | | 130 | | |
| | $R_{(\text{IDRIVE})} = 68\text{ k}\Omega$ to AVDD (DRV8702D) or IDRIVE = 3'b110 (DRV8703D) | | 180 | | |
| | $R_{(\text{IDRIVE})} = 1\text{ k}\Omega$ to AVDD (DRV8702D) or IDRIVE = 3'b111 (DRV8703D) | | 225 | | |
| $I_{\text{DRIVE(SNK_LS)}}$ Low-side peak sink current ($V_{VM} = 13.5\text{V}$) | $R_{(\text{IDRIVE})} < 1\text{ k}\Omega$ to GND (DRV8702D) or IDRIVE = 3'b000 (DRV8703D) | | 20 | | mA |
| | $R_{(\text{IDRIVE})} = 33\text{ k}\Omega$ to GND (DRV8702D) or IDRIVE = 3'b001 (DRV8703D) | | 40 | | |
| | $R_{(\text{IDRIVE})} = 200\text{ k}\Omega$ to GND (DRV8702D) or IDRIVE = 3'b010 (DRV8703D) | | 95 | | |
| | IDRIVE = 3'b011 (DRV8703D) | | 125 | | |
| | IDRIVE = 3'b100 (DRV8703D) | | 180 | | |
| | $R_{(\text{IDRIVE})} > 2\text{ M}\Omega$ to GND (DRV8702D) or IDRIVE = 3'b101 (DRV8703D) | | 260 | | |
| | $R_{(\text{IDRIVE})} = 68\text{ k}\Omega$ to AVDD (DRV8702D) or IDRIVE = 3'b110 (DRV8703D) | | 350 | | |
| | $R_{(\text{IDRIVE})} = 1\text{ k}\Omega$ to AVDD (DRV8702D) or IDRIVE = 3'b111 (DRV8703D) | | 430 | | |
| I_{HOLD} FET holding current | Source current after t_{DRIVE} | | 10 | | mA |
| | Sink current after t_{DRIVE} | | 40 | | |
| I_{STRONG} FET holdoff strong pulldown | GH | | 750 | | mA |
| | GL | | 1000 | | |
| $R_{(\text{OFF})}$ FET gate holdoff resistor | Pulldown GH to SH | | 150 | | k Ω |
| | Pulldown GL to GND | | 150 | | |
| CURRENT SHUNT AMPLIFIER AND PWM CURRENT CONTROL (SP, SN, SO, VREF) | | | | | |
| V_{VREF} VREF input rms voltage | For current internal chopping | | 0.3 ⁽²⁾ | 3.6 | V |

(2) Operational at $V_{\text{VREF}} = 0$ to approximately 0.3 V, but accuracy is degraded.

Electrical Characteristics (continued)

 Over recommended operating conditions unless otherwise noted. Typical limits apply for $T_A = 25^\circ\text{C}$ and $V_{VM} = 13.5\text{ V}$

| PARAMETER | | TEST CONDITIONS | MIN | TYP | MAX | UNIT |
|----------------------------|-----------------------------------------------------------------------------------------------------------------------------------------|---------------------------------------------------------------------|----------------------|-----------------|-------|------------------------------|
| R_{VREF} | VREF input impedance | DRV8702D and DRV8703D VREF_SCL = 00 (100%) | 1 | | | M Ω |
| | | DRV8703D VREF_SCL = 2'b01, 2'b10 or 2'b11 | | 175 | | k Ω |
| A_V | Amplifier gain (DRV8702D-Q1) | $60 < V_{SP} < 225\text{ mV}$; $V_{SN} = \text{GND}$ | 19.3 | 19.8 | 20.3 | V/V |
| A_V | Amplifier gain (DRV8703D-Q1) | GAIN_CS = 00; $10 < V_{SP} < 450\text{ mV}$; $V_{SN} = \text{GND}$ | 9.75 | 10 | 10.25 | V/V |
| | | GAIN_CS = 01; $60 < V_{SP} < 225\text{ mV}$; $V_{SN} = \text{GND}$ | 19.3 | 19.8 | 20.3 | |
| | | GAIN_CS = 10; $10 < V_{SP} < 112\text{ mV}$; $V_{SN} = \text{GND}$ | 38.4 | 39.4 | 40.4 | |
| | | GAIN_CS = 11; $10 < V_{SP} < 56\text{ mV}$; $V_{SN} = \text{GND}$ | 73 | 78 | 81 | |
| V_{IO} | Input-referred offset | $V_{SP} = V_{SN} = \text{GND}$ | | 5 | 10 | mV |
| $V_{IO(DRIFT)}$ | Drift offset ⁽²⁾ | $V_{SP} = V_{SN} = \text{GND}$ | | 10 | | $\mu\text{V}/^\circ\text{C}$ |
| I_{SP} | SP input current | $V_{SP} = 100\text{ mV}$; $V_{SN} = \text{GND}$ | | -20 | | μA |
| V_{SO} | SO pin output voltage range | | $A_V \times V_{OFF}$ | | 4.5 | V |
| $C_{(SO)}$ | Allowable SO pin capacitance | | | | 1 | nF |
| PROTECTION CIRCUITS | | | | | | |
| $V_{(UVLO2)}$ | VM undervoltage lockout | VM falling; UVLO2 report | | 5.25 | 5.45 | V |
| | | VM rising; UVLO2 recovery | | 5.4 | 5.65 | |
| $V_{(UVLO1)}$ | Logic undervoltage lockout | | | | 4.5 | V |
| $V_{hys(UVLO)}$ | VM undervoltage hysteresis | Rising to falling threshold | 100 | | | mV |
| $V_{(CP_UV)}$ | Charge pump undervoltage | VCP falling; CPUV report | | $V_{VM} + 1.5$ | | V |
| | | VCP rising; CPUV recovery | | $V_{VM} + 1.55$ | | |
| $V_{hys(CP_UV)}$ | CP undervoltage hysteresis | Rising to falling threshold | | 50 | | mV |
| $V_{(DS_OCP)}$ | Overcurrent protection trip level, V_{DS} of each external FET (DRV8702D-Q1) High side FETs: VDRAIN – SH Low side FETs: SH – SP | $R_{(VDS)} < 1\text{ k}\Omega$ to GND | | 0.06 | | V |
| | | $R_{(VDS)} = 33\text{ k}\Omega$ to GND | | 0.12 | | |
| | | $R_{(VDS)} = 200\text{ k}\Omega$ to GND | | 0.24 | | |
| | | $R_{(VDS)} > 2\text{ M}\Omega$ to GND | | 0.48 | | |
| | | $R_{(VDS)} = 68\text{ k}\Omega$ to AVDD | | 0.96 | | |
| | | $R_{(VDS)} < 1\text{ k}\Omega$ to AVDD | | Disabled | | |
| $V_{(DS_OCP)}$ | Overcurrent protection trip level, V_{DS} of each external FET (DRV8703D-Q1) High-side FETs: VDRAIN – SH Low-side FETs: SH – SP | VDS_LEVEL = 3'b000 | | 0.06 | | V |
| | | VDS_LEVEL = 3'b001 | | 0.145 | | |
| | | VDS_LEVEL = 3'b010 | | 0.17 | | |
| | | VDS_LEVEL = 3'b011 | | 0.2 | | |
| | | VDS_LEVEL = 3'b100 | | 0.12 | | |
| | | VDS_LEVEL = 3'b101 | | 0.24 | | |
| | | VDS_LEVEL = 3'b110 | | 0.48 | | |
| | | VDS_LEVEL = 3'b111 | | 0.96 | | |
| $V_{(SP_OCP)}$ | Overcurrent protection trip level, measured by sense amplifier | V_{SP} with respect to GND | 0.8 | 1 | 1.2 | V |
| $T_{(OTW)}$ | Thermal warning temperature ⁽¹⁾ | Die temperature T_J | 120 | 135 | 145 | $^\circ\text{C}$ |
| T_{SD} | Thermal shutdown temperature ⁽¹⁾ | Die temperature T_J | 150 | | | $^\circ\text{C}$ |
| T_{hys} | Thermal shutdown hysteresis ⁽¹⁾ | Die temperature T_J | | 20 | | $^\circ\text{C}$ |
| $V_{C(GS)}$ | Gate-drive clamping voltage | Positive clamping voltage | 16.3 | 17 | 17.8 | V |
| | | Negative clamping voltage | -1 | -0.7 | -0.5 | |

6.6 SPI Timing Requirements

| | | MIN | NOM | MAX | UNIT |
|-----------------|---------------------------------------------|-----|-----|-----|------|
| $t_{(CLK)}$ | Minimum SPI clock period | 100 | | | ms |
| $t_{(CLKH)}$ | Clock high time | 50 | | | ns |
| $t_{(CLKL)}$ | Clock low time | 50 | | | ns |
| $t_{su(SDI)}$ | SDI input data setup time | 20 | | | ns |
| $t_h(SDI)$ | SDI input data hold time | 30 | | | ns |
| $t_h(SDO)$ | SDO output hold time | 40 | | | ns |
| $t_{su(SCS)}$ | SCS setup time | 50 | | | ns |
| $t_h(SCS)$ | SCS hold time | 50 | | | ns |
| $t_{(HL_SCS)}$ | SCS minimum high time before SCS active low | 400 | | | ns |

6.7 Switching Characteristics

Over recommended operating conditions unless otherwise noted

| PARAMETER | TEST CONDITIONS | MIN | TYP | MAX | UNIT | | | |
|---------------------------------------------------------------------------|-------------------------------------------|-------------------------------------------------------------------------------------------------|-----|-----|------|---------|---------|-----|
| POWER SUPPLIES (VM, AVDD, DVDD) | | | | | | | | |
| $t_{(SLEEP)}$ | Sleep time | nSLEEP = low to sleep mode | | | 100 | μ s | | |
| $t_{(wu)}$ | Wake-up time | nSLEEP = high to output change | | | 1 | ms | | |
| t_{on} | Turnon time | VM > UVLO2 to output transition | | | 1 | ms | | |
| CHARGE PUMP (VCP, CPH, CPL) | | | | | | | | |
| $f_{S(VCP)}$ | Charge-pump switching frequency | VM > UVLO2 | | | 200 | 400 | 700 | kHz |
| CONTROL INPUTS (IN1, IN2, nSLEEP, MODE, nSCS, SCLK, SDI) | | | | | | | | |
| t_{pd} | Propagation delay | IN1, IN2 or PH, EN to GH or GL | | | 500 | | ns | |
| FET GATE DRIVERS (GH, GH, SH, SH, GL, GL) | | | | | | | | |
| $t_{(DEAD)}$ | Output dead time (DRV8702D-Q1) | Observed $t_{(DEAD)}$ depends on IDRIVE setting | | | 240 | | ns | |
| $t_{(DEAD)}$ | Output dead time (DRV8703D-Q1) | TDEAD = 2'b00; Observed $t_{(DEAD)}$ depends on IDRIVE setting | | | 120 | ns | | |
| | | TDEAD = 2'b01; Observed $t_{(DEAD)}$ depends on IDRIVE setting | | | 240 | | | |
| | | TDEAD = 2'b10; Observed $t_{(DEAD)}$ depends on IDRIVE setting | | | 480 | | | |
| | | TDEAD = 2'b11; Observed $t_{(DEAD)}$ depends on IDRIVE setting | | | 960 | | | |
| $t_{(DRIVE)}$ | Gate drive time | | | | 2.5 | | μ s | |
| CURRENT SHUNT AMPLIFIER AND PWM CURRENT CONTROL (SP, SN, SO, VREF) | | | | | | | | |
| t_s | Settling time to $\pm 1\%$ ⁽¹⁾ | $V_{SP} = V_{SN} = GND$ to $V_{SP} = 240$ mV, $V_{SN} = GND$, $A_V = 10$; $C_{(SO)} = 200$ pF | | | 0.5 | μ s | | |
| | | $V_{SP} = V_{SN} = GND$ to $V_{SP} = 120$ mV, $V_{SN} = GND$, $A_V = 20$; $C_{(SO)} = 200$ pF | | | 1 | | | |
| | | $V_{SP} = V_{SN} = GND$ to $V_{SP} = 60$ mV, $V_{SN} = GND$, $A_V = 40$; $C_{(SO)} = 200$ pF | | | 2 | | | |
| | | $V_{SP} = V_{SN} = GND$ to $V_{SP} = 30$ mV, $V_{SN} = GND$, $A_V = 80$; $C_{(SO)} = 200$ pF | | | 4 | | | |
| t_{off} | PWM off-time (DRV8702D-Q1) | | | | 25 | | μ s | |
| t_{off} | PWM off-time (DRV8703D-Q1) | TOFF = 00 | | | 25 | μ s | | |
| | | TOFF = 01 | | | 50 | | | |
| | | TOFF = 10 | | | 100 | | | |
| | | TOFF = 11 | | | 200 | | | |
| $t_{(BLANK)}$ | PWM blanking time | | | | 2 | | μ s | |

(1) Ensured by design

Switching Characteristics (continued)

Over recommended operating conditions unless otherwise noted

| PARAMETER | TEST CONDITIONS | MIN | TYP | MAX | UNIT | |
|----------------------------|-------------------------------------------------------|-------------------------|-----|-----|---------------|----|
| PROTECTION CIRCUITS | | | | | | |
| $t_{(UVLO)}$ | VM UVLO falling deglitch time | VM falling; UVLO report | | 10 | μs | |
| $t_{(OCP)}$ | Overcurrent deglitch time | 3.7 | 4 | 4.3 | μs | |
| $t_{(RETRY)}$ | Overcurrent retry time | 2.8 | 3 | 3.2 | ms | |
| $t_{(WD)}$ | Watchdog time out (DRV8703D-Q1) | WD_DLY = 2'b00 | | 10 | ms | |
| | | WD_DLY = 2'b01 | | 20 | | |
| | | WD_DLY = 2'b10 | | 50 | | |
| | | WD_DLY = 2'b11 | | 100 | | |
| $t_{(RESET)}$ | Watchdog timer reset period | | | 64 | μs | |
| SPI | | | | | | |
| $t_{(SPI_READY)}$ | SPI read after power on | VM > VUVLO1 | | 5 | 10 | ms |
| $t_{d(SDO)}$ | SDO output data delay time, CLK high to SDO high | $C_L = 20 \text{ pF}$ | | 30 | | ns |
| t_a | SCS access time, SCS low to SDO out of high impedance | | | 10 | ns | |
| t_{dis} | SCS disable time, SCS high to SDO high impedance | | | 10 | ns | |

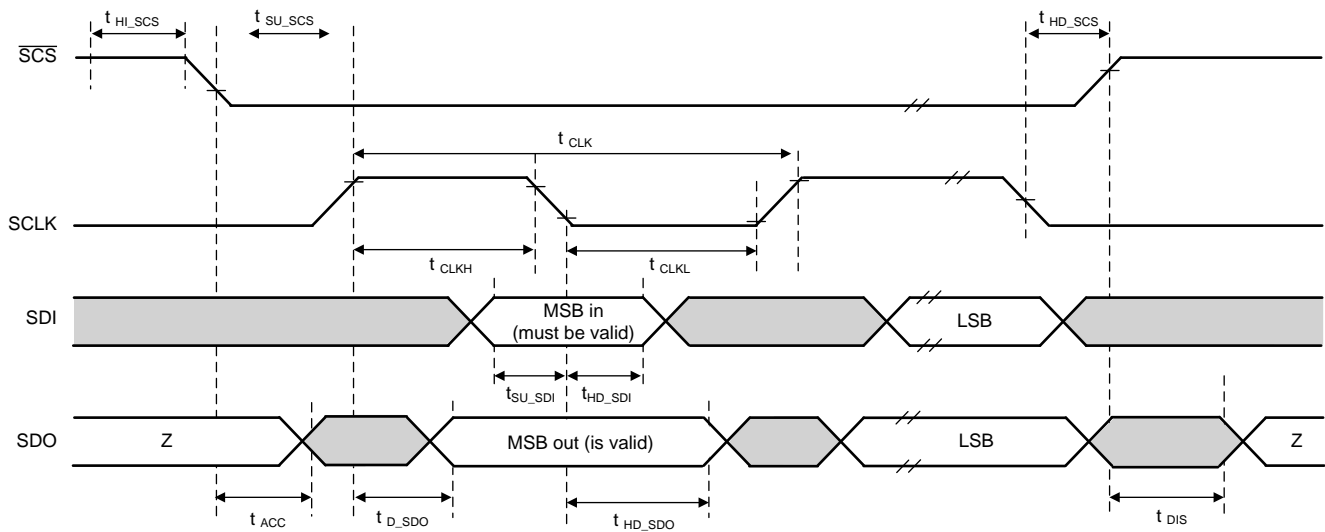
Figure 1. SPI Slave Mode Timing Definition

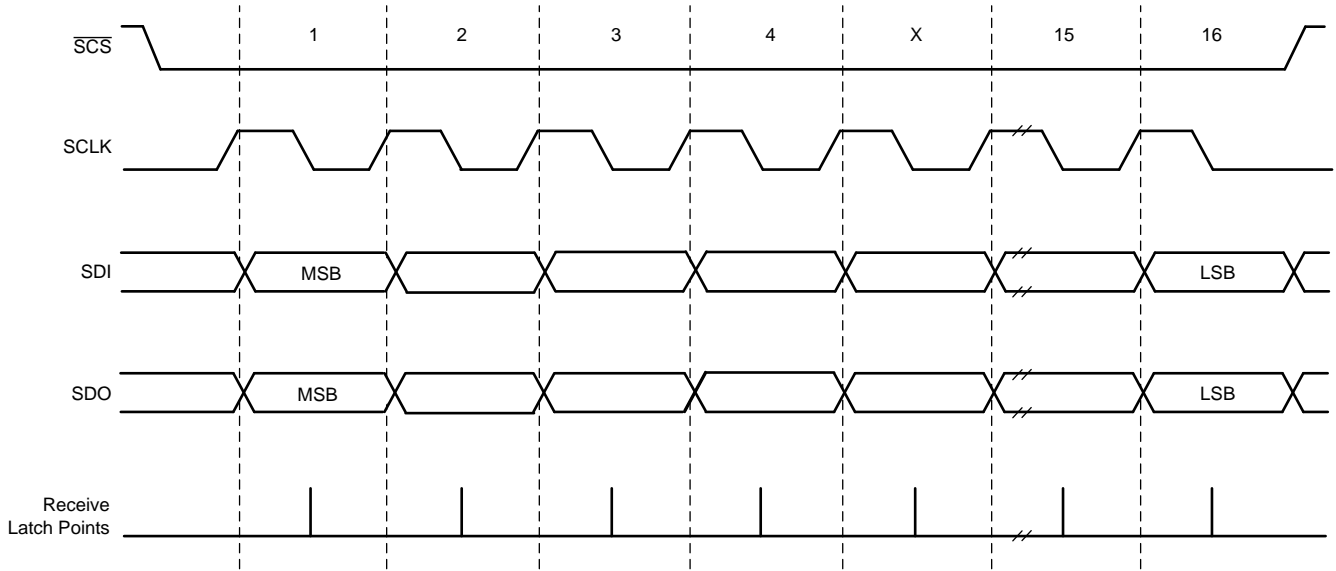

Figure 2. SPI Slave Mode Timing Diagram

6.8 Typical Characteristics

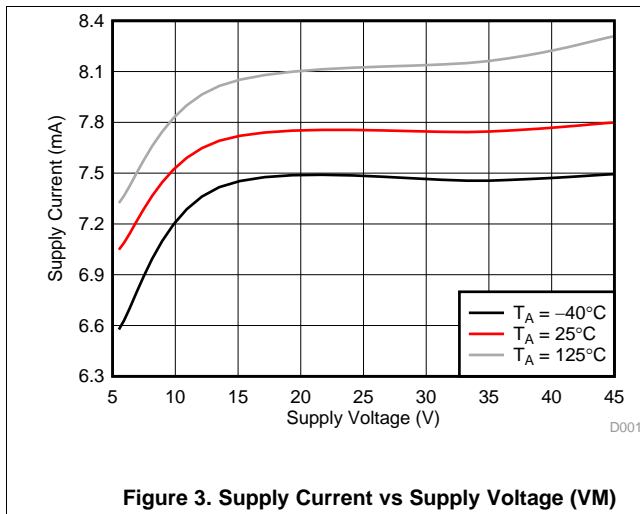

Figure 3. Supply Current vs Supply Voltage (VM)

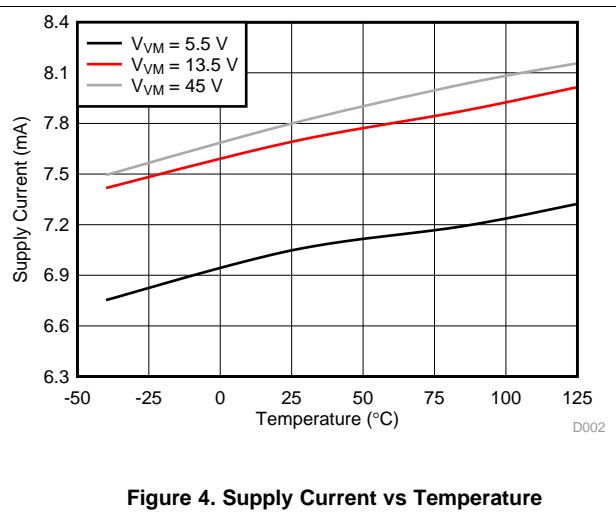

Figure 4. Supply Current vs Temperature

Typical Characteristics (continued)

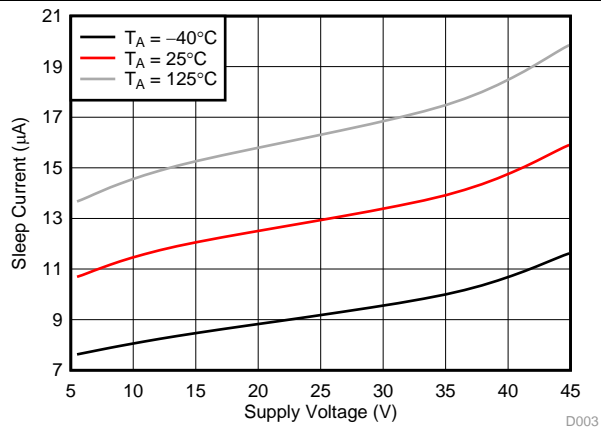

Figure 5. Sleep Current vs Supply Voltage (VM)

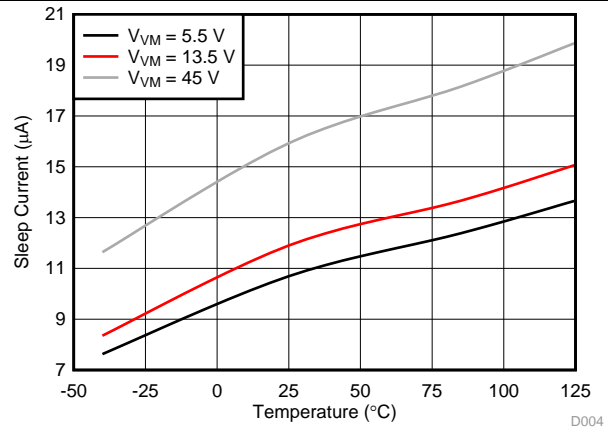

Figure 6. Sleep Current vs Temperature

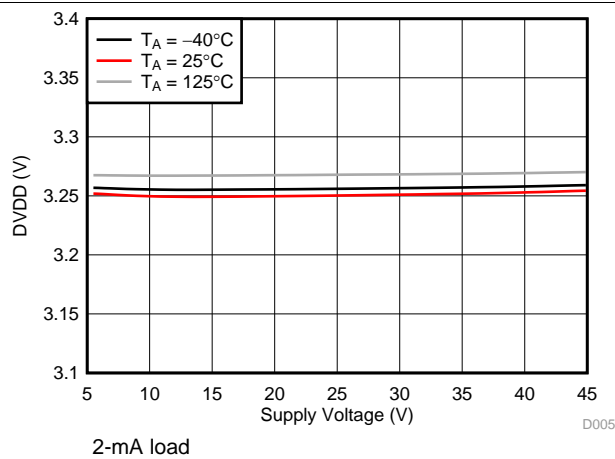

Figure 7. DVDD Regulator

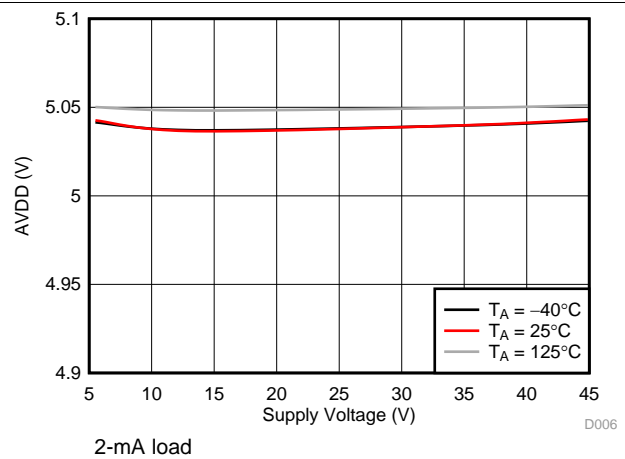

Figure 8. AVDD Regulator

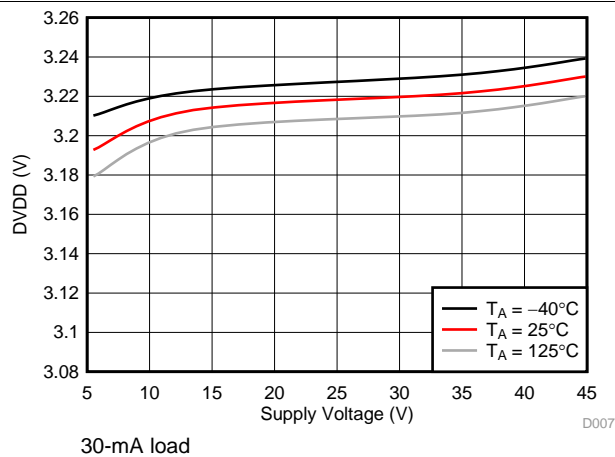

Figure 9. DVDD Regulator

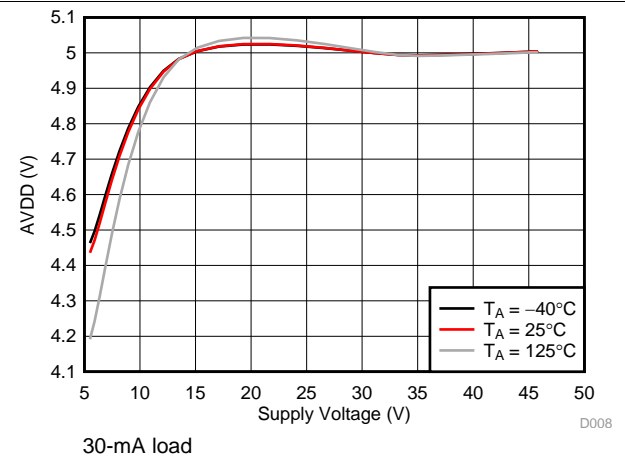
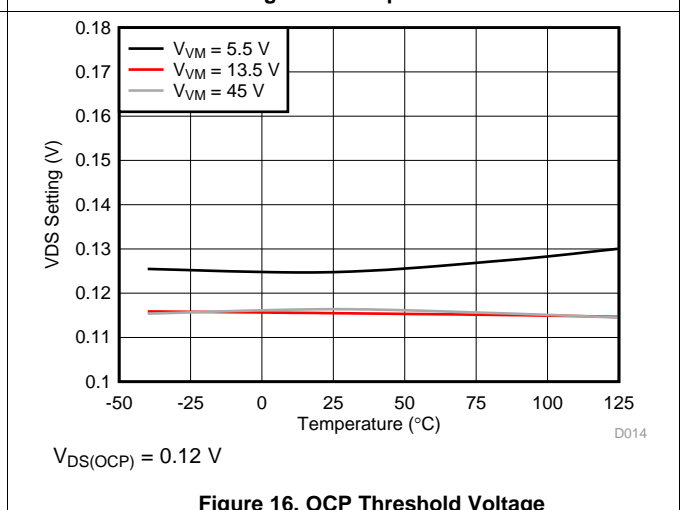
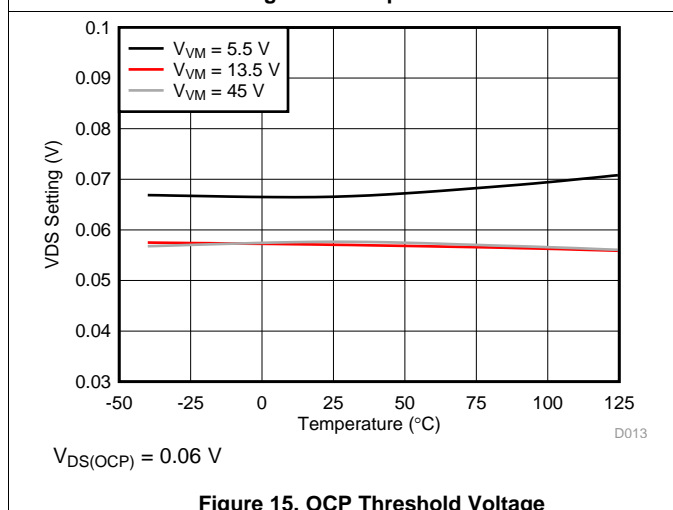
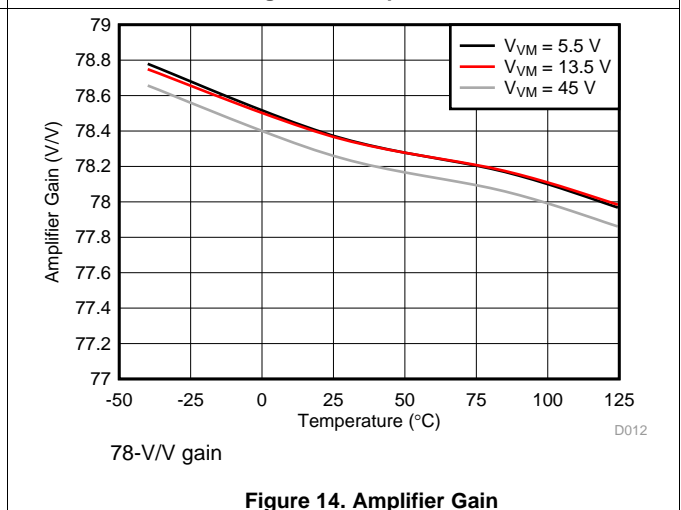
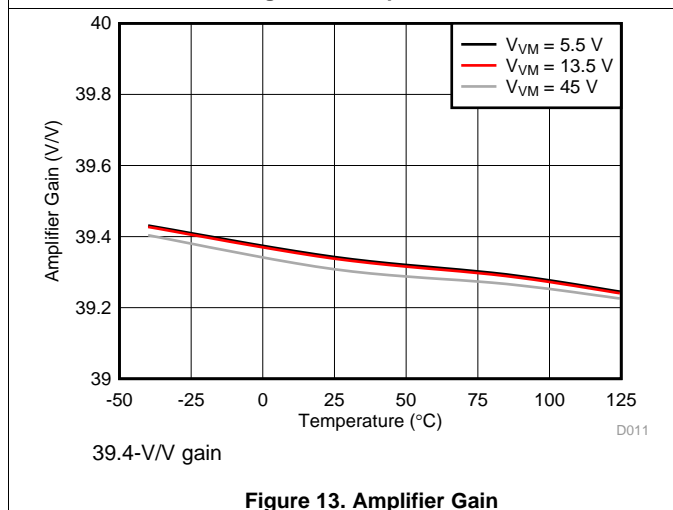
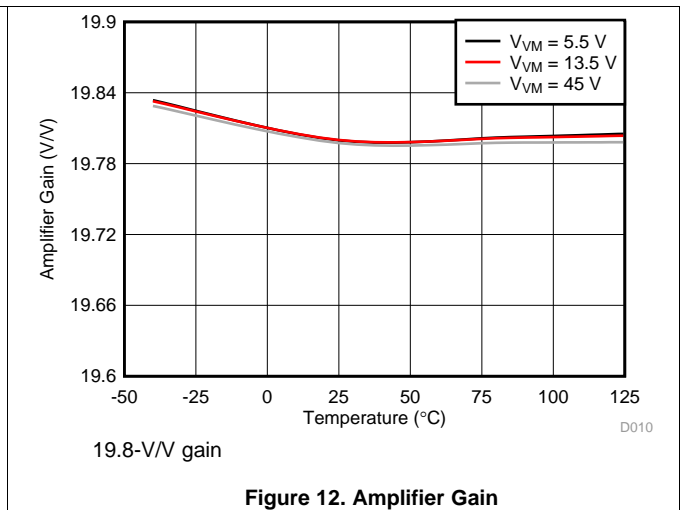
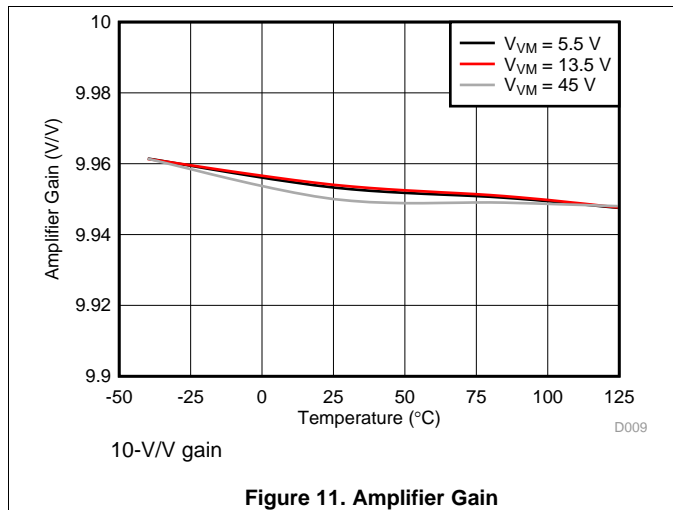

Figure 10. AVDD Regulator

Typical Characteristics (continued)



Typical Characteristics (continued)

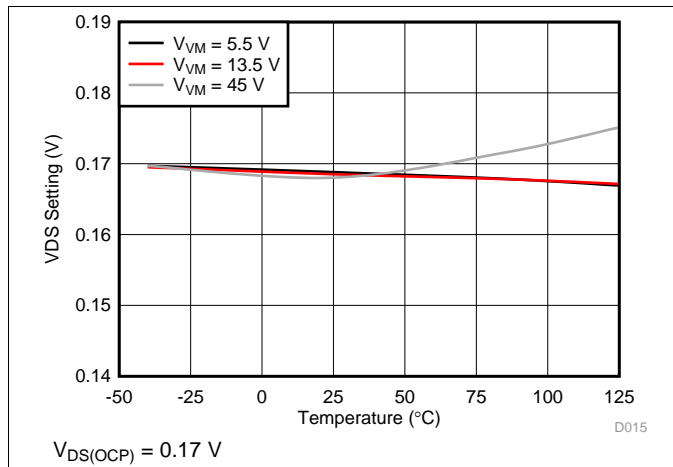

Figure 17. OCP Threshold Voltage

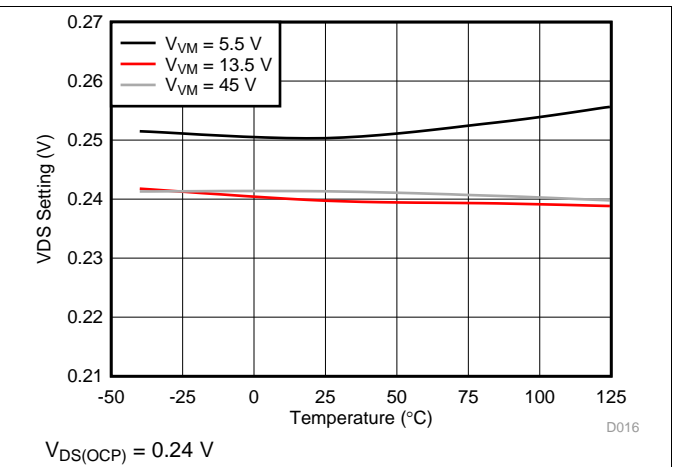

Figure 18. OCP Threshold Voltage

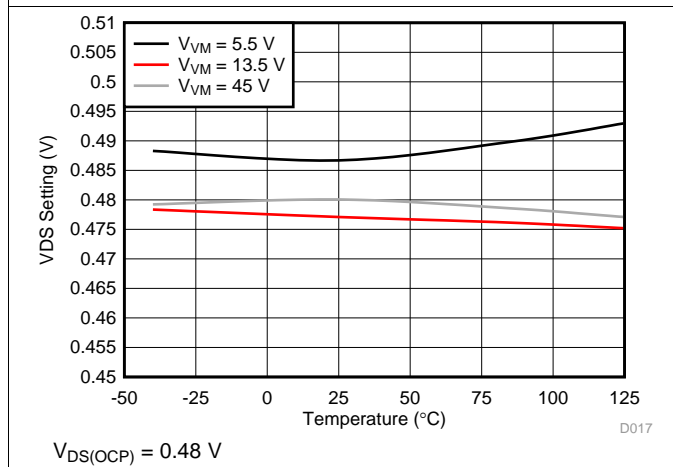

Figure 19. OCP Threshold Voltage

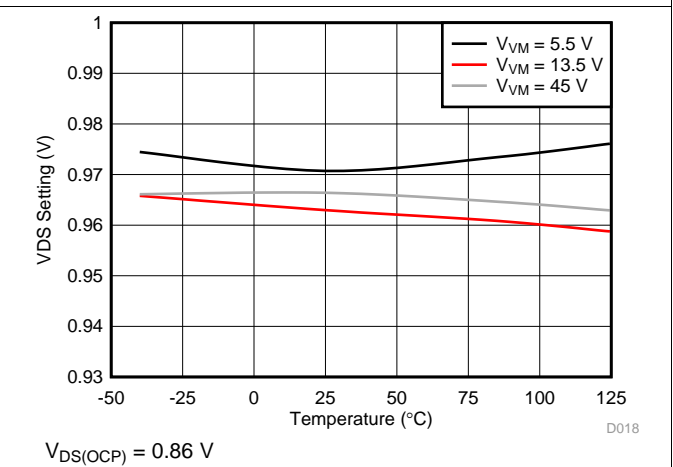

Figure 20. OCP Threshold Voltage

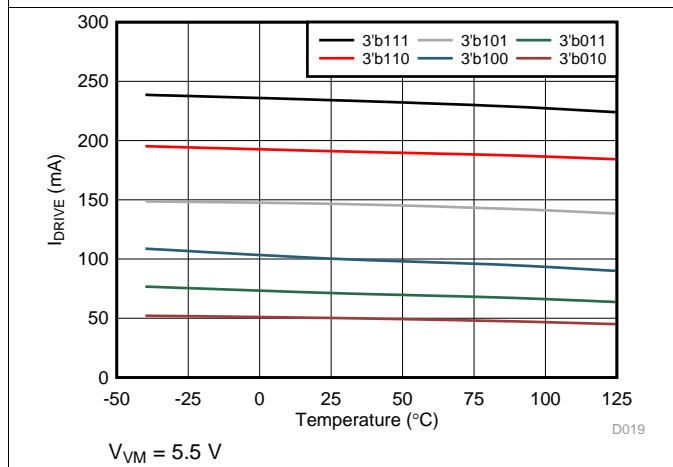

Figure 21. High-Side Source Current

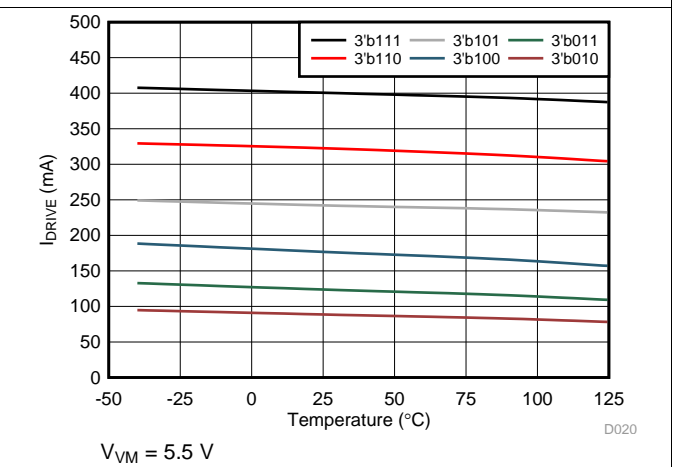

Figure 22. High-Side Sink Current

Typical Characteristics (continued)

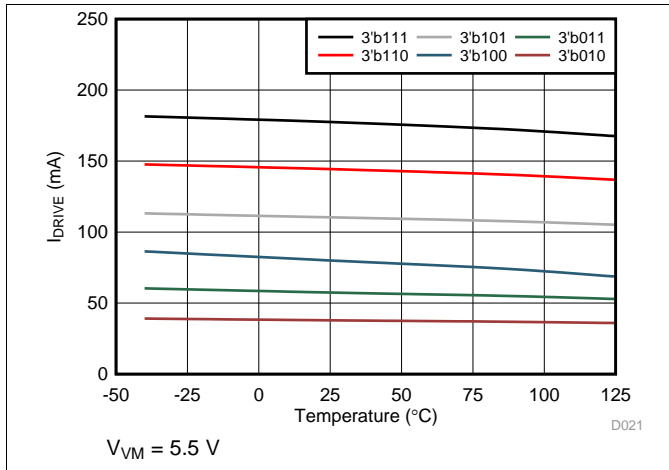

Figure 23. Low-Side Source Current

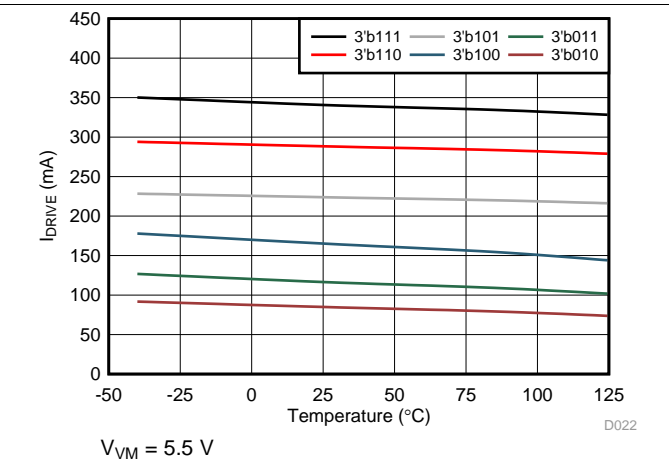

Figure 24. Low-Side Sink Current

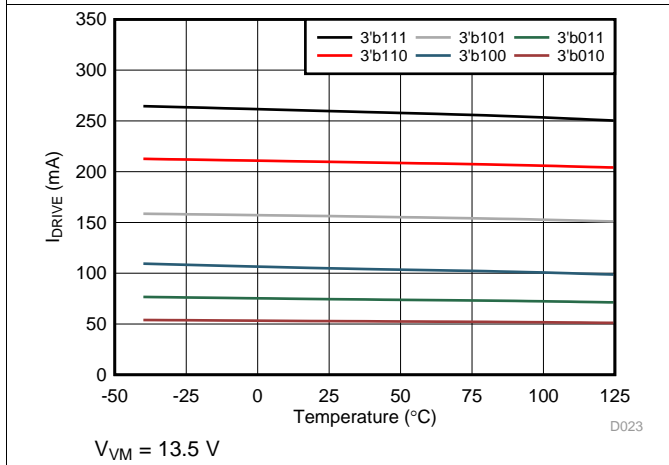

Figure 25. High-Side Source Current

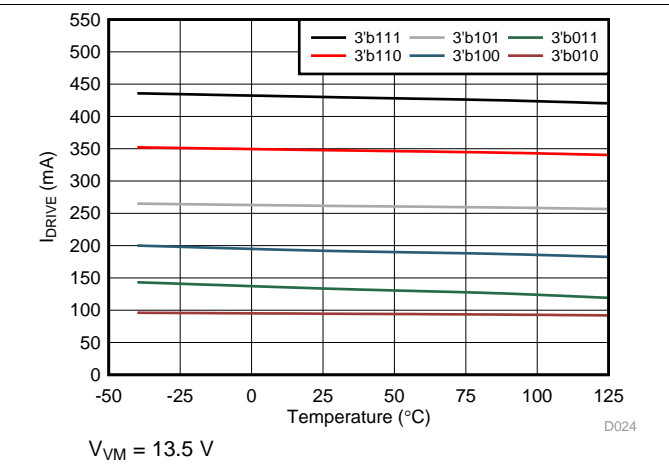

Figure 26. High-Side Sink Current

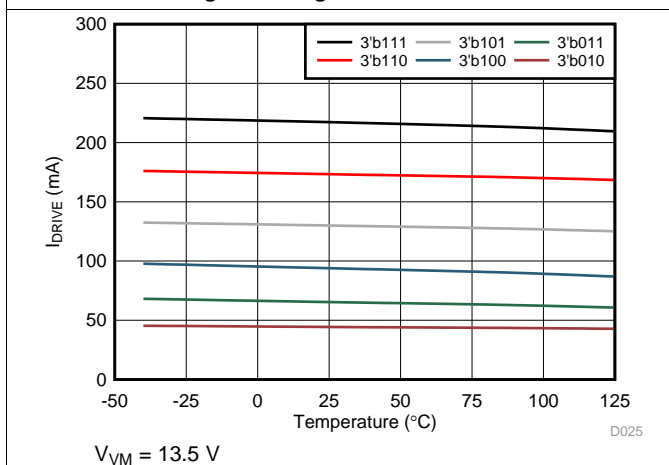

Figure 27. Low-Side Source Current

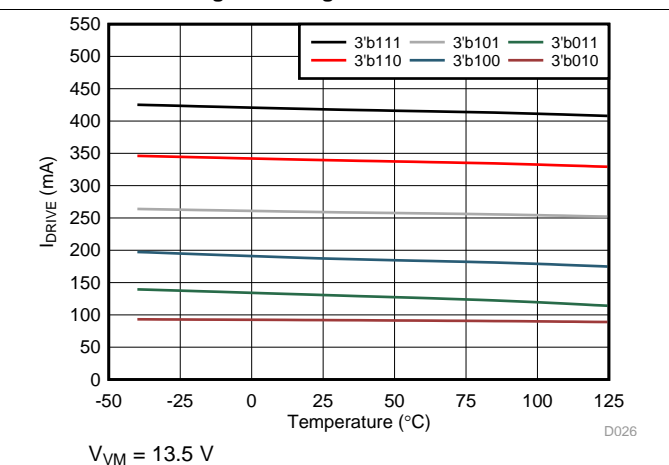

Figure 28. Low-Side Sink Current

7 Detailed Description

7.1 Overview

The DRV870xD-Q1 device is an half-bridge gate driver (also called a gate controller). The device integrates FET gate drivers to control two external NMOS FETs. The device can be powered with a supply voltage from 5.5 V to 45 V.

The device has a low-power sleep mode that is enabled using the nSLEEP pin.

The gate drive strength can be adjusted to optimize a system for a given FET size without adding external series resistors. The IDRIVE pin allows for selection of the peak current driven into the external FET gate. Both the high-side and low-side FETs are driven with a gate source voltage (V_{GS}) of 10.5 V (nominal) when the VM voltage is more than 13.5 V. At lower VM voltages, the V_{GS} is reduced. The high-side gate drive voltage is generated using a doubler-architecture charge pump that regulates to the $VM + 10.5$ V.

This device significantly reduces the component count of discrete motor-driver systems by integrating the required FET drive circuitry into a single device. The DRV870xD-Q1 device also has protection features beyond traditional discrete implementations including: undervoltage lockout (UVLO), overcurrent protection (OCP), gate-driver faults, and thermal shutdown (TSD).

A start-up (inrush) or running current limitation is built in using a fixed time-off current chopping scheme. The chopping current level is set by selecting the value of the sense resistor and setting a voltage on the VREF pin.

A shunt-amplifier output provides accurate current measurements by the system controller. The SO pin outputs a voltage that is approximately 20 times the voltage across the sense resistor on the DRV8702D-Q1 device. For the DRV8703D-Q1, this gain is configurable.

7.2 Functional Block Diagram

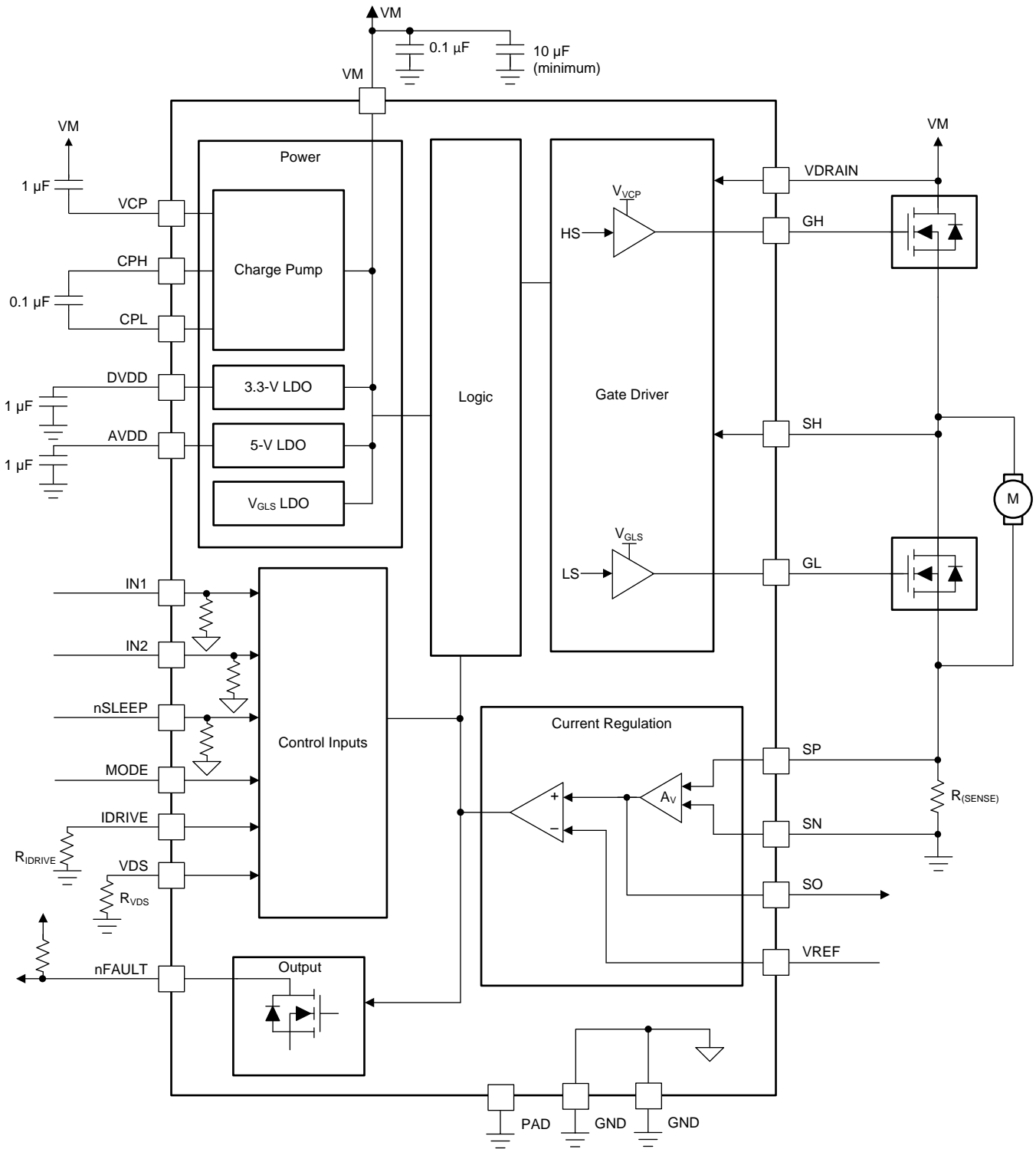

Copyright © 2017, Texas Instruments Incorporated

Figure 29. DRV8702D-Q1 Functional Block Diagram

Functional Block Diagram (continued)

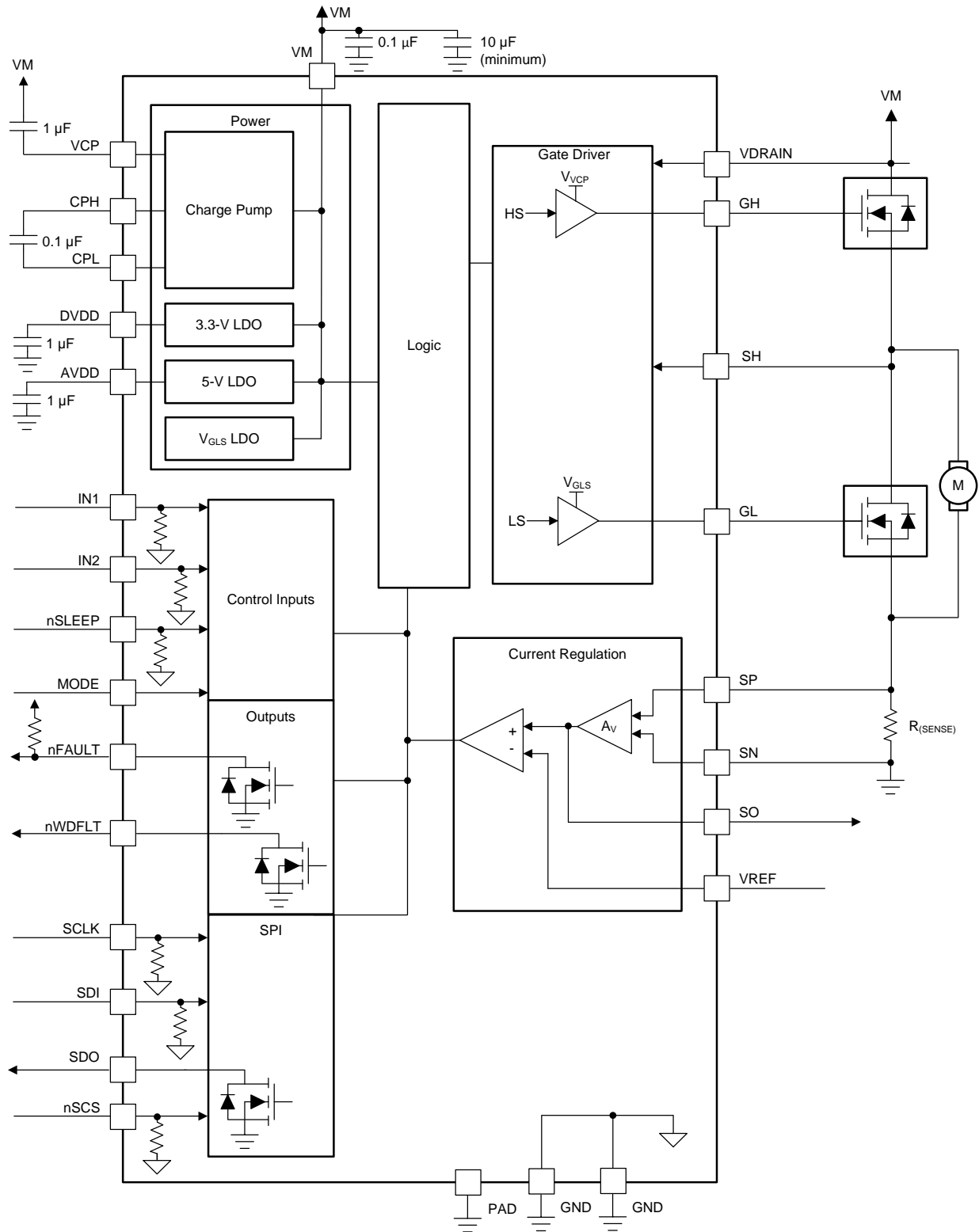

Copyright © 2017, Texas Instruments Incorporated

Figure 30. DRV8703D-Q1 Functional Block Diagram

7.3 Feature Description

Table 1 and Table 2 list the recommended external components for the device.

Table 1. External Components

| COMPONENT | PIN 1 | PIN 2 | RECOMMENDED |
|----------------------|----------------|-----------|--------------------------------------------------------------------------|
| $C_{(VM1)}$ | VM | GND | 0.1- μ F ceramic capacitor rated for VM |
| $C_{(VM2)}$ | VM | GND | ≥ 10 - μ F electrolytic capacitor rated for VM |
| $C_{(VCP)}$ | VCP | VM | 16-V, 1- μ F ceramic capacitor |
| $C_{(SW)}$ | CPH | CPL | 0.1- μ F X7R capacitor rated for VM |
| $C_{(DVDD)}$ | DVDD | GND | 6.3-V, 1- μ F ceramic capacitor |
| $C_{(AVDD)}$ | AVDD | GND | 6.3-V, 1- μ F ceramic capacitor |
| $R_{(IDRIVE)}$ | IDRIVE | GND | For resistor sizing, see the Typical Application section |
| $R_{(VDS)}$ | VDS | GND | For resistor sizing, see the Typical Application section |
| $R_{(nFAULT)}$ | $V_{CC}^{(1)}$ | nFAULT | ≥ 10 k Ω |
| $R_{(nWDFLT)}$ | $V_{CC}^{(1)}$ | nWDFLT | ≥ 10 k Ω |
| $R_{(SENSE)}$ | SP | SN or GND | Optional low-side sense resistor |
| $R_{(VDRAIN)}^{(2)}$ | VDRAIN | VM | 100- Ω series resistor |

- (1) The V_{CC} pin is not a pin on the DRV870xD-Q1, but a V_{CC} supply voltage pullup is required for open-drain outputs nFAULT. These pins can be pulled up to either AVDD or DVDD.
- (2) The $R_{(VDRAIN)}$ resistor should be used between the VDRAIN and VM pins to minimize current to the VDRAIN pin if no external reserve battery protection is implemented on the VDRAIN pin.

Table 2. External Gates

| COMPONENT | GATE | DRAIN | SOURCE | RECOMMENDED |
|------------|------|-------|-----------|--------------------------------------------------------------------------|
| $Q_{(HS)}$ | GH | VM | SH | Supports FETs up to 200 nC at 40 kHz PWM |
| $Q_{(LS)}$ | GL | SH | SP or GND | For more information, see Application and Implementation |

7.3.1 Bridge Control

The DRV870xD-Q1 device is controlled using a configurable input interface. The [Logic Tables](#) section provides the half-bridge operation states. These tables do not consider the current control built into the DRV870xD-Q1 device. The logic operation set by the MODE pin is latched on power-up or when exiting sleep mode. [Figure 31](#) shows the direction of the flow of current through the load when it is connected between the SH pin and GND, and between the SH pin and VM.

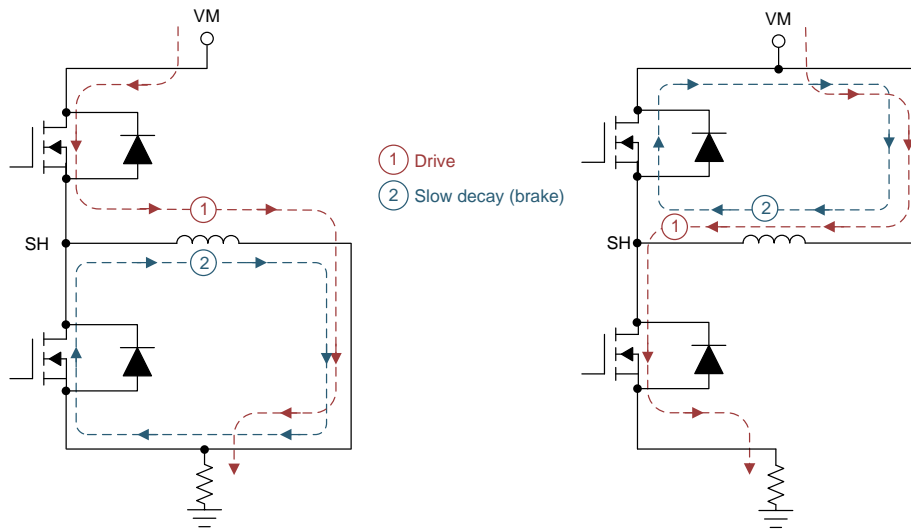

Figure 31. Bridge Control

7.3.1.1 Logic Tables

Table 3, and Table 4 are the device logic tables. An X denotes a don't care input or output.

NOTE

Any other input logic combinations, aside from the ones mentioned in [Table 3](#) and [Table 4](#), result in an error, and the device will trigger a fault.

Table 3. DRV870xD-Q1 PWM Control Interface Without Current Regulation (MODE = 1)

| nSLEEP | IN1 | IN2 | GH | GL | SH | AVDD/DVDD | Description |
|--------|-----|-----|----|----|------|-----------|------------------------------|
| 0 | X | X | X | X | Hi-Z | Disabled | Sleep mode ½-bridge disabled |
| 1 | 0 | 0 | 0 | 1 | L | Enabled | ½-bridge low side on |
| 1 | 1 | 0 | 1 | 0 | H | Enabled | ½-bridge high side on |

Table 4. DRV870xD-Q1 PWM Control Interface With Current Regulation (MODE = Hi-Z)

| nSLEEP | IN1 | IN2 | GH | GL | SH | AVDD/DVDD | Description |
|--------|-----|-----|----|----|------|-----------|------------------------------|
| 0 | X | X | X | X | Hi-Z | Disabled | Sleep mode ½-bridge disabled |
| 1 | 0 | 0 | 0 | 0 | Hi-Z | Enabled | ½-bridge is in tri-state |
| 1 | 1 | 0 | 1 | 0 | H | Enabled | ½-bridge high-side on |
| 1 | 1 | 1 | 0 | 1 | L | Enabled | ½-bridge low-side on |

If MODE = Hi-Z is selected, the device performs current regulation (refer to the [Current Regulation](#) section). Having both the input (INx) pins high puts the motor in brake mode (low-side slow decay). If MODE = 1 is selected, current regulation is disabled and must be performed externally using a MCU. With MODE = 1, the load current recirculation occurs through the high-side FET as shown in [Figure 31](#).

7.3.2 MODE Pin

The MODE pin of the device determines the control interface and latches on power-up or when exiting sleep mode. Figure 32 shows an overview of the internal circuit of the MODE pin.

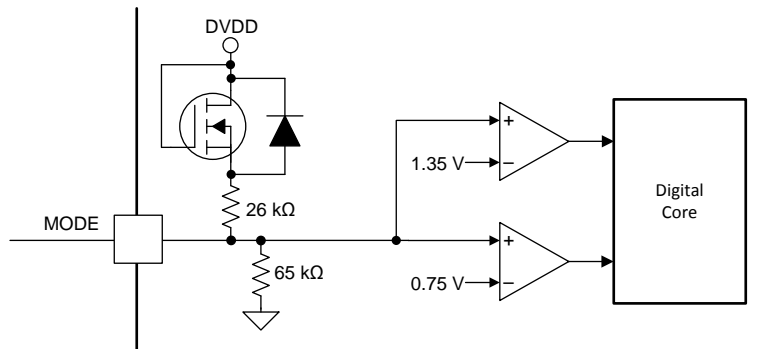

Figure 32. MODE Pin Block Diagram

Table 5 lists the different control interfaces that can be set via MODE pin at power-up or when exiting sleep mode.

Table 5. MODE Pin Configuration

| MODE | CONTROL INTERFACE |
|------|--------------------------------------------------|
| 1 | PWM control interface without current regulation |
| Hi-Z | PWM control interface with current regulation |

During the device power-up sequence, the DVDD pin is enabled first. Then the MODE pin latches. Finally the AVDD pin is enabled. For setting PWM control interface, TI does not recommend connecting the MODE pin to the AVDD pin. Instead the MODE pin should be connected to an external 5-V or 3.3-V supply or to the DVDD pin if not driven by an external microcontroller (MCU).

7.3.3 nFAULT Pin

The nFAULT pin has an open-drain output and should be pulled up to a 5-V or 3.3-V supply. When a fault is detected, the nFAULT line is logic low.

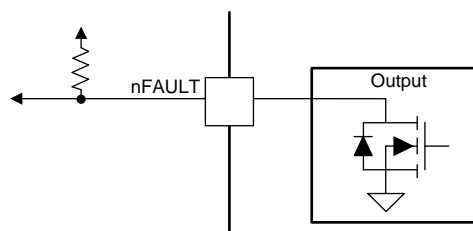

Figure 33. nFAULT Block Diagram

For a 3.3-V pullup the nFAULT pin can be tied to the DVDD pin with a resistor (refer to the [Application and Implementation](#) section). For a 5-V pullup an external 5-V supply should be used. TI does not recommend connecting the nFAULT pin to the AVDD pin.

7.3.4 Current Regulation

The maximum current through the motor winding is regulated by a fixed off-time PWM current regulation or current chopping. When a half-bridge is enabled, current rises through the winding at a rate dependent on the DC voltage and inductance of the winding. When the current hits the current chopping threshold, the bridge enters a brake (low-side slow decay) mode until the t_{off} time expires.

NOTE

Immediately after the current is enabled, the voltage on the SP pin is ignored for a period (t_{BLANK}) before enabling the current-sense circuitry.

The PWM chopping current is set by a comparator that compares the voltage across a current-sense resistor connected to the SP pin, multiplied by a factor of A_V , with a reference voltage from the VREF pin. The factor A_V is the shunt-amplifier gain, which is 19.8 V/V for the DRV8702D-Q1 device or configurable to 10, 19.8, 39.4, or 78 V/V for the DRV8703D-Q1 device.

Use [Equation 1](#) to calculate the chopping current (I_{CHOP}).

$$I_{\text{CHOP}} = \frac{V_{\text{VREF}} - V_{\text{IO}}}{A_V \times R_{\text{(SENSE)}}} \quad (1)$$

For example, if a 50-m Ω sense resistor and a VREF value of 3.3 V are selected, the full-scale chopping current is 3.28 A. The A_V is 19.8 V/V and V_{IO} is assumed to be 50 mV in this example.

NOTE

If the load is connected between the SH pin and VM and current regulation is enabled (MODE pin is Hi-Z), the low-side FET is switched on when the current flowing through the load exceeds the ICHOP threshold. This results in an adverse effect by driving the load at 100% duty cycle because the maximum current flows through the load as the low-side FET remains switched on for the t_{OFF} duration. Texas Instruments recommends using the PWM control interface without current regulation (MODE pin is 1) for this configuration to drive the load.

For DC motors, current regulation is used to limit the start-up and stall current of the motor. If the current regulation feature is not needed, it can be disabled by tying the VREF pin directly to the AVDD pin. If the PWM control-interface mode without current regulation (MODE pin is 1) is selected for operation, the device does not perform PWM current regulation or current chopping.

7.3.5 Amplifier Output (SO)

The SO pin on the DRV870xD-Q1 device outputs an analog voltage equal to the voltage across the SP and SN pins multiplied by A_V . The SO voltage is only valid for when the load is connected in the way shown in [Figure 31](#). Use [Equation 2](#) to calculate the approximate current for the half-bridge.

$$I = \frac{V_{\text{SO}} - V_{\text{IO}}}{A_V \times R_{\text{(SENSE)}}} \quad (2)$$

When the SP and SN voltages are 0 V, the SO pin outputs the amplifier offset voltage, V_{IO} . No capacitor is required on the SO pin.

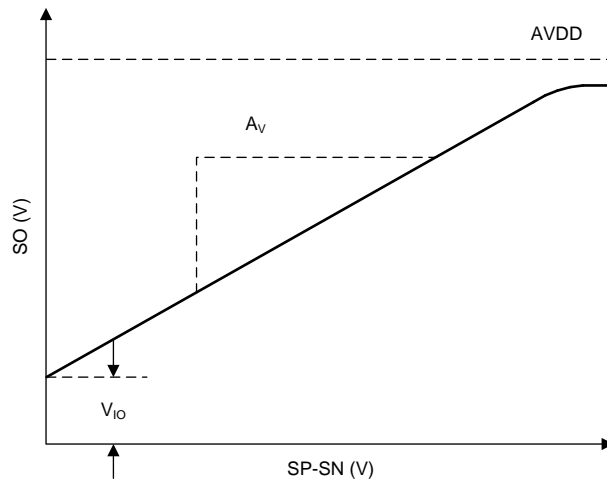

Figure 34. Current Sense Amplifier Output

If the voltage across the SP and SN pins exceeds 1 V, then the DRV870xD-Q1 device flags an overcurrent condition.

The SO pin can source up to 5 mA of current. If the pin is shorted to ground, or if this pin drives a higher current load, the output functions as a constant-current source. The output voltage is not representative of the half-bridge current in this state.

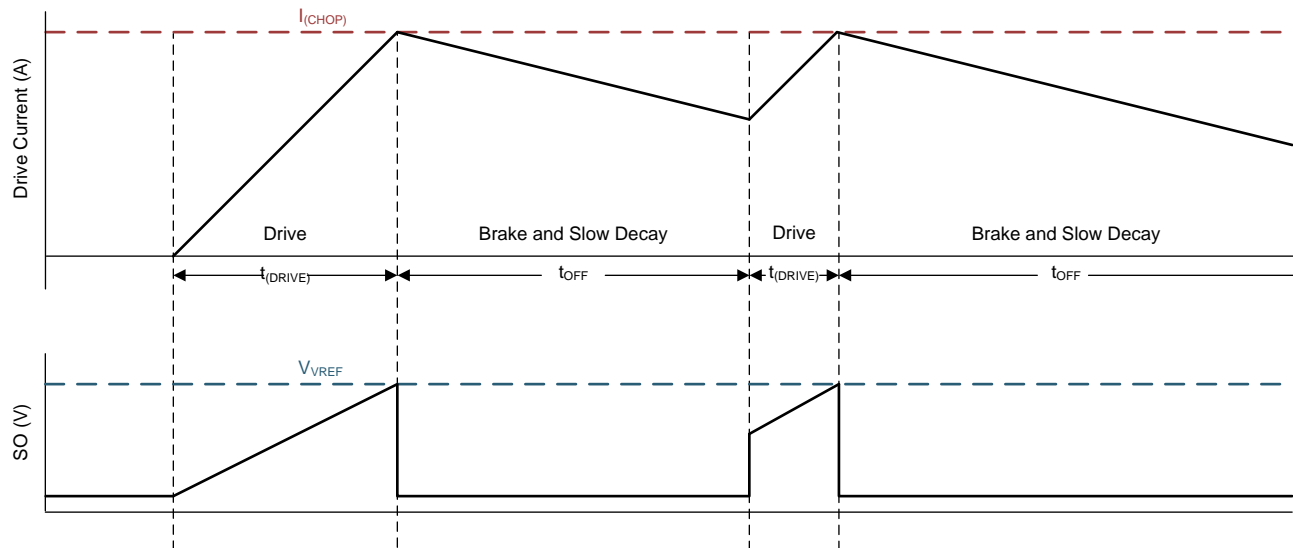

Figure 35. Current Sense Amplifier and Current Chopping Operation

During brake mode (slow decay), current is circulated through the low-side FET. Because current is not flowing through the sense resistor, the SO pin does not represent the motor current.

7.3.5.1 SO Sample and Hold Operation

The DRV8703D-Q1 device allows the shunt amplifier to operate in a sample and hold configuration. To enable this mode, set the SH_EN bit high through the SPI. In this mode, the shunt amplifier output is disabled to the Hi-Z state whenever the driver is in a brake mode. Place an external capacitor on this pin.

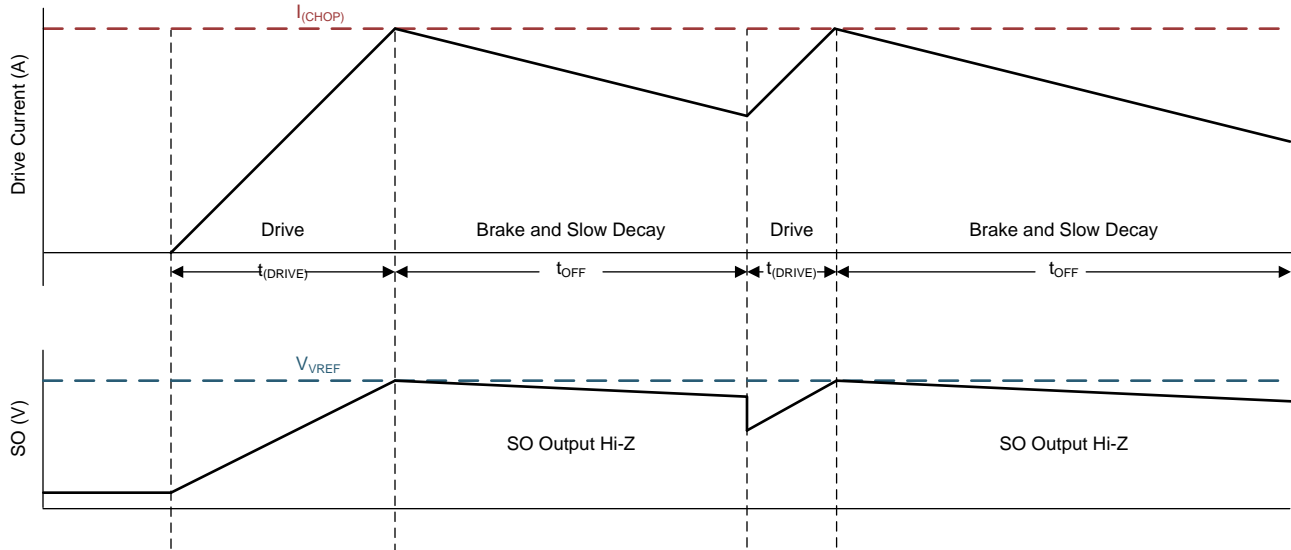

Figure 36. Sample and Hold Operation

7.3.6 PWM Motor Gate Drivers

The DRV870xD-Q1 device has gate drivers for a single half-bridge with external NMOS FETs. Figure 37 shows a block diagram of the predrive circuitry.

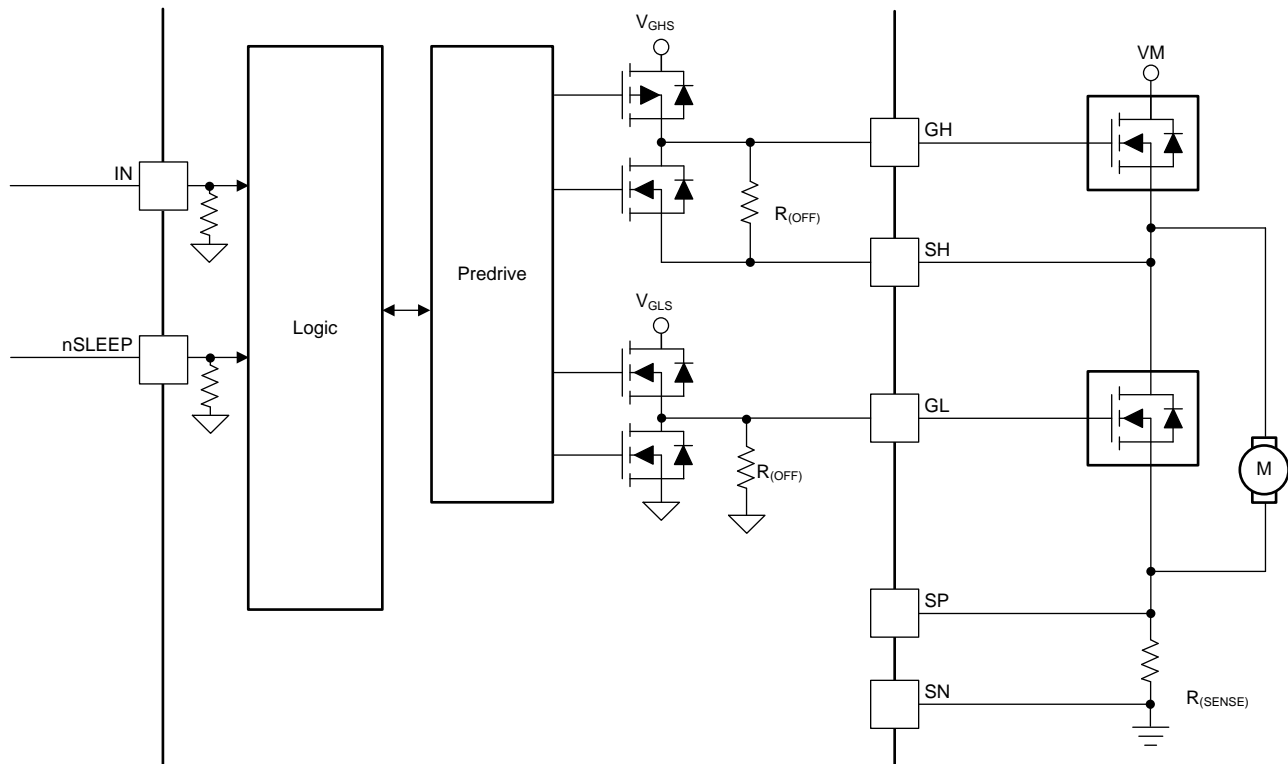

Figure 37. Predrive Block Diagram

Gate drivers inside the DRV870xD-Q1 device directly drive N-Channel MOSFETs, which drive the motor current. The high-side gate drive is supplied by the charge pump, while an internal regulator generates the low-side gate drive.

The peak drive current of the gate drivers is adjustable through the IDRIVE pin for DRV8702D-Q1 device or the IDRIVE register for the DRV8703D-Q1 device. Peak source currents can be set to the values listed in the FET gate drivers section of the [Electrical Characteristics](#) table. The peak sink current is approximately two times the peak source current. Adjusting the peak current changes the output slew rate, which also depends on the FET input capacitance and gate charge.

Fast switching times can cause extra noise on the VM and GND pins. This additional noise can occur specifically because of a relatively slow reverse-recovery time of the low-side body diode, when the body diode conducts reverse-bias momentarily, similar to shoot-through. Slow switching times can cause excessive power dissipation because the external FETs have a longer turnon and turnoff time.

When changing the state of the output, the peak current (I_{DRIVE}) is applied for a short period ($t_{(DRIVE)}$), to charge the gate capacitance. After this time, a weak current source (I_{HOLD}) is used to keep the gate at the desired state. When selecting the gate drive strength for a given external FET, the selected current must be high enough to charge fully and discharge the gate during $t_{(DRIVE)}$, or excessive power is dissipated in the FET.

During high-side turnon, the low-side gate is pulled low with a strong pulldown (I_{STRONG}). This pulldown prevents the low-side FET Q_{GS} from charging and keeps the FET off, even when fast switching occurs at the outputs.

The gate-driver circuits include enforcement of a dead time in analog circuitry, which prevents the high-side and low-side FETs from conducting at the same time. When the switching FETs are on, this handshaking prevents the high-side or low-side FET from turning on until the opposite FET turns off.

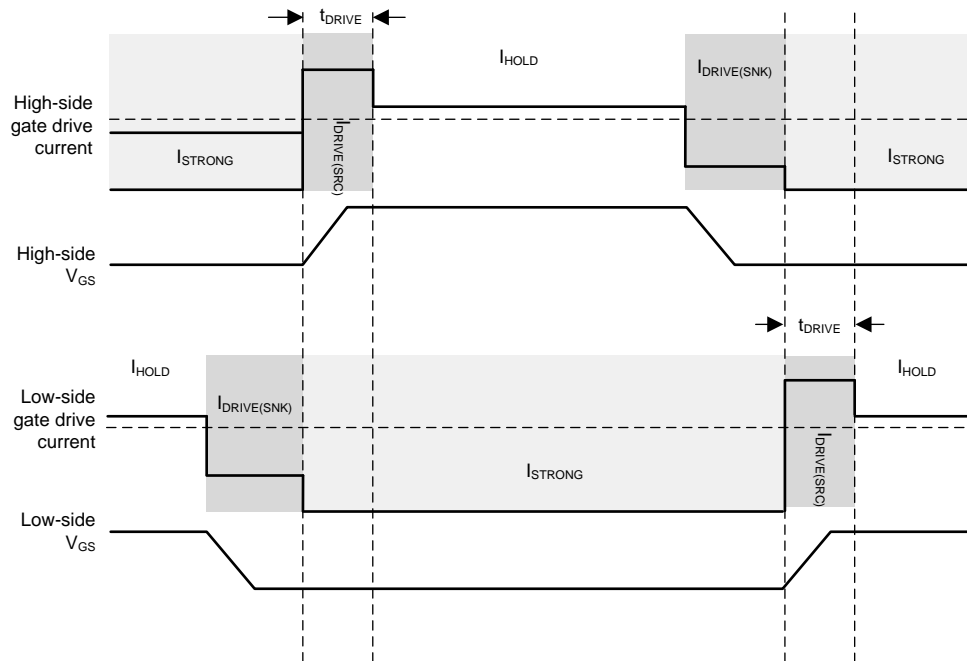

Figure 38. Gate Driver Output to Control External FETs

7.3.6.1 Miller Charge (Q_{GD})

When a FET gate turns on, the following capacitances must be charged:

- Gate-to-source charge, Q_{GS}
- Gate-to-drain charge, Q_{GD} (Miller charge)
- Remaining Q_G

The FET output is slewing primarily during the Q_{GD} charge.

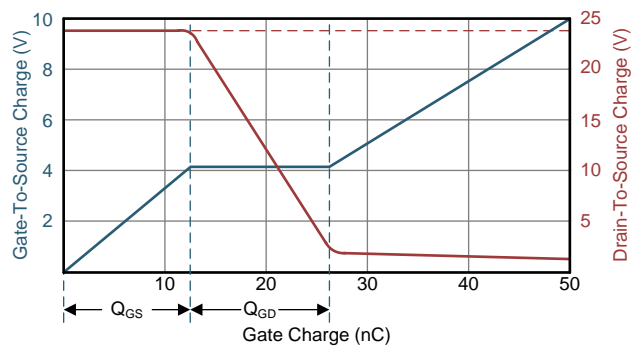
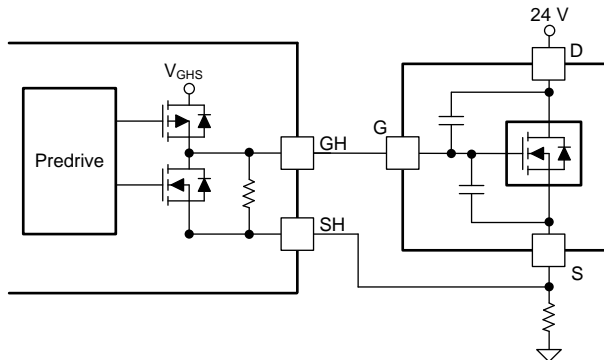

Figure 39. FET Gate Charging Profile

7.3.7 IDRIVE Pin (DRV8702D-Q1 Only)

The rise and fall times of the half-bridge output (SH pin) can be adjusted by setting the IDRIVE resistor value or forcing a voltage onto the IDRIVE pin. The FET gate voltage ramps faster if a higher IDRIVE setting is selected. The ramp of the FET gate directly affects the rise and fall times of the half-bridge output.

Tying the IDRIVE pin to ground selects the lowest drive setting of 10-mA source and 20-mA sink. Leaving this pin open selects the drive setting of 155-mA high side and 130-mA low side for source current, and 265-mA high side, 260-mA low side for sink current, at a VM voltage of 13.5 V. For a detailed list of IDRIVE configurations, see [Table 6](#).

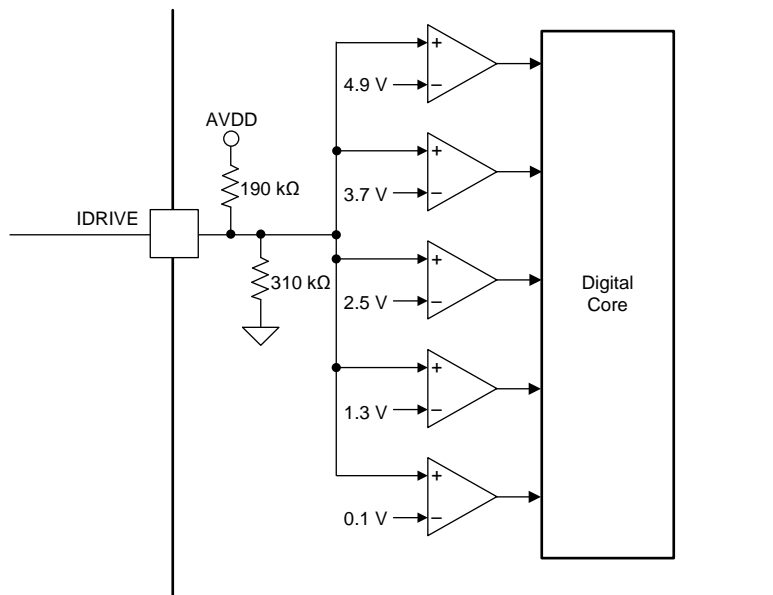
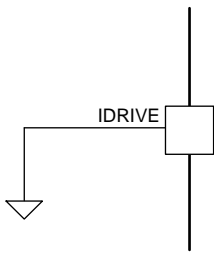
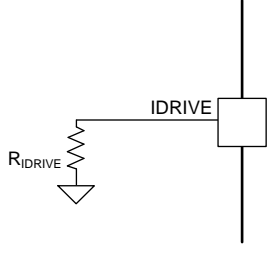
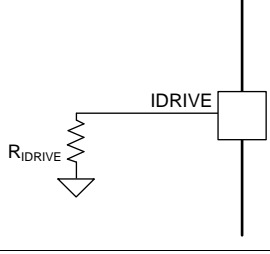
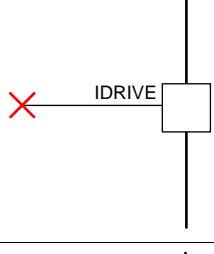
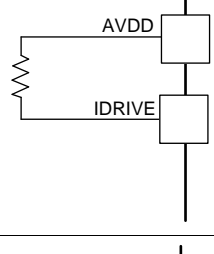
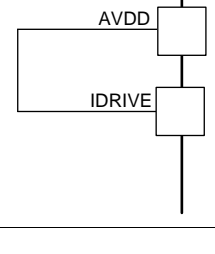

Figure 40. IDRIVE Pin Internal Circuitry

Table 6. DRV8702D-Q1 IDRIVE Settings

| IDRIVE RESISTANCE | IDRIVE VOLTAGE | SOURCE CURRENT | | SINK CURRENT | | CIRCUIT |
|---------------------|----------------|---------------------------------------|---------------------------------------|---------------------------------------|---------------------------------------|---------------------------------------------------------------------------------------|
| | | V _{VM} = 5.5 V | V _{VM} = 13.5 V | V _{VM} = 5.5 V | V _{VM} = 13.5 V | |
| < 1 kΩ to GND | GND | High-side: 10 mA Low-side: 10 mA | High-side: 10 mA Low-side: 10 mA | High-side: 20 mA Low-side: 20 mA | High-side: 20 mA Low-side: 20 mA |  |
| 33 kΩ ± 5% to GND | 0.7 V ± 5% | High-side: 20 mA Low-side: 20 mA | High-side: 20 mA Low-side: 20 mA | High-side: 40 mA Low-side: 40 mA | High-side: 40 mA Low-side: 40 mA |  |
| 200 kΩ ± 5% to GND | 2 V ± 5% | High-side: 50 mA Low-side: 40 mA | High-side: 50 mA Low-side: 45 mA | High-side: 90 mA Low-side: 85 mA | High-side: 95 mA Low-side: 95 mA |  |
| > 2 MΩ to GND, Hi-Z | 3 V ± 5% | High-side: 145 mA Low-side: 115 mA | High-side: 155 mA Low-side: 130 mA | High-side: 250 mA Low-side: 235 mA | High-side: 265 mA Low-side: 260 mA |  |
| 68 kΩ ± 5% to AVDD | 4 V ± 5% | High-side: 190 mA Low-side: 145 mA | High-side: 210 mA Low-side: 180 mA | High-side: 330 mA Low-side: 300 mA | High-side: 350 mA Low-side: 350 mA |  |
| < 1 kΩ to AVDD | AVDD | High-side: 240 mA Low-side: 190 mA | High-side: 260 mA Low-side: 225 mA | High-side: 420 mA Low-side: 360 mA | High-side: 440 mA Low-side: 430 mA |  |

7.3.8 Dead Time

The dead time (t_{DEAD}) is measured as the time when the SH pin is in the Hi-Z state between turning off one of the half-bridge FETs and turning on the other. For example, the output is Hi-Z between turning off the high-side FET and turning on the low-side FET.

The dead time consists of an inserted digital dead time and FET gate slewing. The DRV8702D-Q1 device has a digital dead time of approximately 240 ns. The DRV8703D-Q1 device has programmable dead-time options of 120, 240, 480, 960 ns. In addition to this digital dead time, the output is Hi-Z as long as the voltage across the GL pin to ground or GH pin to SH pin is less than the FET threshold voltage.

The total dead time is dependent on the IDRIVE resistor setting because a portion of the FET gate ramp (GH and GL pins) includes the observable dead time.

7.3.9 Propagation Delay

The propagation delay time (t_{PD}) is measured as the time between an input edge to an output change. This time is composed of two parts: an input deglitcher and output slewing delay. The input deglitcher prevents noise on the input pins from affecting the output state.

The gate drive slew rate also contributes to the delay time. For the output to change state during normal operation, one FET must first be turned off. The FET gate is ramped down according to the IDRIVE resistor selection, and the observed propagation delay ends when the FET gate falls below the threshold voltage.

7.3.10 Overcurrent VDS Monitor

The gate-driver circuit monitors the VDS voltage of each external FET when it is driving current. When the voltage monitored is greater than the OCP threshold voltage ($V_{DS(OCP)}$) after the OCP deglitch time has expired, an OCP condition is detected. The VDS voltage can be adjusted by changing the resistor ($R_{(VDS)}$) on the VDS pin of the DRV8702D-Q1 device. The DRV8703D-Q1 device provides VDS voltage levels by setting the VDS register.

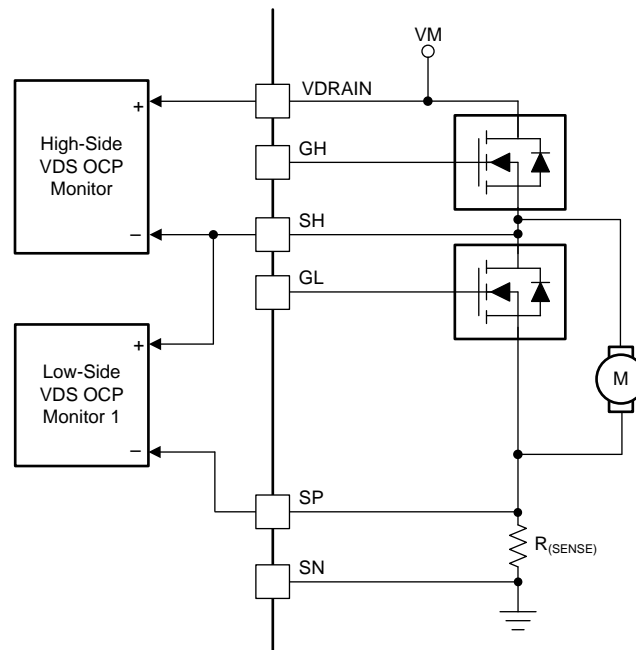

Figure 41. $V_{DS(OCP)}$ Block Diagram

The VDS voltage on the high-side FET is measured across the VDRAIN to SH pin. The low-side VDS monitor measures the VDS voltage across the SH to SP pins. Ensure that the SP pin is always connected to the source of the low-side FET of half-bridge, even when the sense amplifier is not used.

7.3.11 VDS Pin (DRV8702D-Q1 Only)

The VDS pin on the DRV8702D-Q1 device is used to select the VDS threshold voltage for overcurrent detection.

Tying the VDS pin to ground selects the lowest setting of 0.06 V. Leaving this pin open selects the setting of 0.48 V. Tying the VDS pin to the AVDD the pin disables the VDS monitor. For a detailed list of VDS configurations, see [Table 7](#).

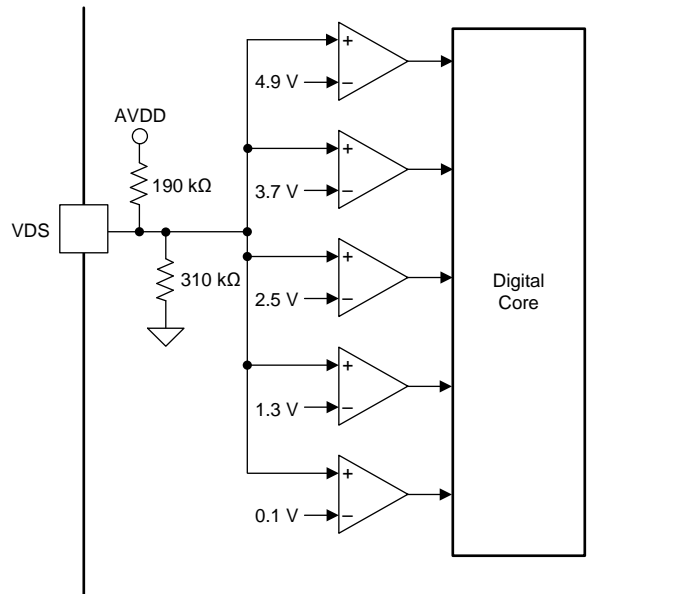
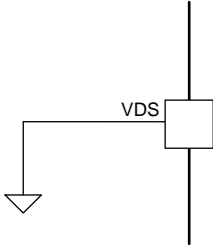
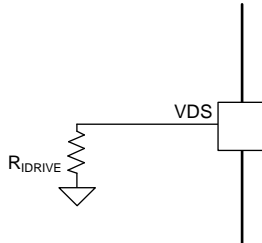
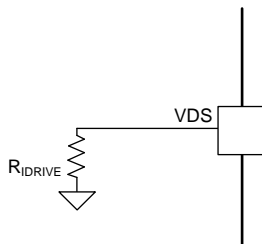
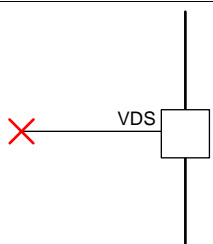
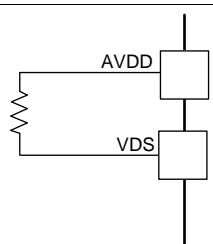
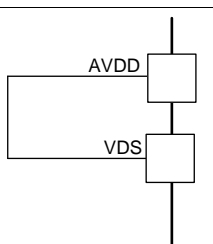

Figure 42. VDS Block Diagram

Table 7. VDS Pin Resistor Setting

| VDS RESISTANCE | VDS VOLTAGE | OVERCURRENT TRIP LEVEL ($V_{DS(OCF)}$) | CIRCUIT |
|--------------------------------|----------------|------------------------------------------|---------------------------------------------------------------------------------------|
| < 1 k Ω to GND | GND | 0.06 V |  |
| 33 k Ω \pm 5% to GND | 0.7 V \pm 5% | 0.12 V |  |
| 200 k Ω \pm 5% to GND | 2 V \pm 5% | 0.24 V |  |
| > 2 M Ω to GND, Hi-Z | 3 V \pm 5% | 0.48 V |  |
| 68 k Ω \pm 5% to AVDD | 4 V \pm 5% | 0.96 V |  |
| < 1 k Ω to AVDD | AVDD | Disabled |  |

7.3.12 Charge Pump

A charge pump is integrated to supply the gate drive voltage of a high-side NMOS (V_{GS_H}). The charge pump requires a capacitor between the VM and VCP pins. Additionally, a low-ESR ceramic capacitor is required between the CPH and CPL pins. When the VM voltage is below 13.5 V, this charge pump functions as a doubler and generates a V_{VCP} equal to $2 \times V_{VM} - 1.5$ V if unloaded. When the VM voltage is more than 13.5 V, the charge pump regulates V_{VCP} such that it is equal to $V_{VM} + 10.5$ V.

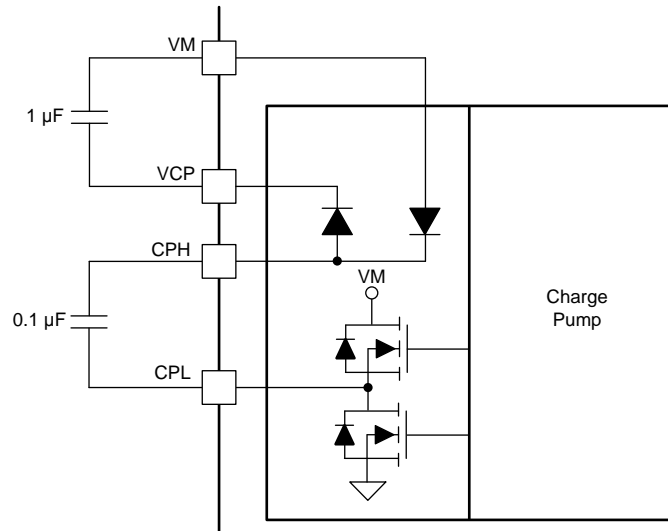

Figure 43. Charge Pump Block Diagram

7.3.13 Gate Drive Clamp

A clamping structure limits the gate-drive output voltage to the $V_{C(GS)}$ voltage to protect the power FETs from damage. The positive voltage clamp is realized using a series of diodes. The negative voltage clamp uses the body diodes of the internal predriver FET.

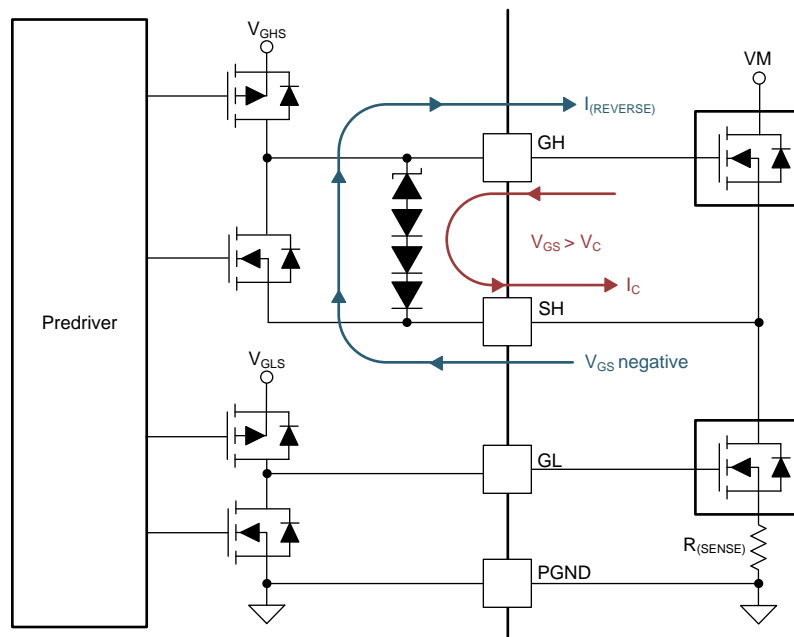

Figure 44. Gate Drive Clamp

7.3.14 Protection Circuits

The DRV870xD-Q1 device is fully protected against VM undervoltage, charge-pump undervoltage, overcurrent, gate-driver shorts, and overtemperature events.

7.3.14.1 VM Undervoltage Lockout (UVLO2)

If the voltage on the VM pin falls below the VM undervoltage lockout threshold voltage (V_{UVLO2}), both FETs in the half-bridge are disabled, the charge pump is disabled, and the nFAULT pin is driven low. The VM_UVFL bit of the DRV8703D-Q1 device is set. The operation resumes when the VM voltage rises above the UVLO2 threshold. The nFAULT pin is released after the operation resumes but the VM_UVFL bit on the DRV8703D-Q1 device remains set until cleared by writing to the CLR_FLT bit.

The SPI settings on the DRV8703D-Q1 device are not reset by this fault even though the output drivers are disabled. The settings are maintained and internal logic remains active until the VM voltage falls below the logic undervoltage threshold (V_{UVLO1}).

7.3.14.2 Logic Undervoltage (UVLO1)

If the voltage on the VM pin falls below the logic undervoltage threshold voltage (V_{UVLO1}), the internal logic is reset. The operation resumes when the VM voltage rises above the UVLO1 threshold. The nFAULT pin is logic low during this state because it is pulled low when the VM undervoltage condition occurs. Decreasing the VM voltage below this undervoltage threshold resets the SPI settings.

7.3.14.3 VCP Undervoltage Lockout (CPUV)

If the voltage on the VCP pin falls below the threshold voltage of the charge-pump undervoltage (CPUV) lockout, both FETs in the half-bridge are disabled and the nFAULT pin is driven low. The DRV8703D-Q1 the VCP_UVFL bit is set. The operation resumes when the VCP voltage rises above the CPUV threshold. The nFAULT pin is released after the operation resumes but the VCP_UVFL bit on the DRV8703D-Q1 device remains set until cleared by writing to the CLR_FLT bit.

7.3.14.4 Overcurrent Protection (OCP)

Overcurrent is sensed by monitoring the VDS voltage drop across the external FETs. If the voltage across a driven FET exceeds the $V_{DS(OCP)}$ level for longer than the OCP deglitch time, an OCP event is recognized. Both FETs in the half-bridge are disabled, and the nFAULT pin is driven low. The OCP bit of the DRV8703D-Q1 device is set. The drive re-enables after the $t_{(RETRY)}$ time has passed. The nFAULT pin becomes high again after the retry time.

If the fault condition is still present, the cycle repeats. If the fault is no longer present, normal operation resumes and the nFAULT pin goes high. The OCP bit on the DRV8703D-Q1 remains set until cleared by writing to the CLR_FLT bit. In addition to this FET VDS monitor, an overcurrent condition is detected if the voltage at the SP pin exceeds $V_{SP(OCP)}$ and the nFAULT pin is driven low. The OCP bit in the DRV8703-Q1 device is set.

7.3.14.5 Gate Driver Fault (GDF)

The GH and GL pins are monitored such that if the voltage on the external FET gate does not increase or decrease after the $t_{(DRIVE)}$ time, a gate driver fault is detected. This fault occurs if the GH or GL pins are shorted to the GND, SH, or VM pin. Additionally, a gate-driver fault occurs if the selected IDRIVE setting is not sufficient to turn on the external FET. Both FETs in the half-bridge are disabled, and the nFAULT pin is driven low. The GDF bit of the DRV8703D-Q1 device is set. The driver re-enables after the OCP retry period ($t_{(RETRY)}$) has passed. The nFAULT pin is released after the operation has resumed but the GDF bit on the DRV8703D-Q1 device remains set until cleared by writing to the CLR_FLT bit.

7.3.14.6 Thermal Shutdown (TSD)

If the die temperature exceeds the T_{SD} temperature, both FETs in the half-bridge are disabled, the charge pump shuts down, the AVDD regulator is disabled, and the nFAULT pin is driven low. The OTSD bit of the DRV8703D-Q1 device is set as well. After the die temperature falls below $T_{SD} - T_{hys}$ temperature, device operation automatically resumes. The nFAULT pin is released after the operation resumes, but the OTSD bit on the DRV8703D-Q1 device remains set until cleared by writing to the CLR_FLT bit.

7.3.14.7 Watchdog Fault (WDFLT, DRV8703D-Q1 Only)

An MCU watchdog function can be enabled to ensure that the external controller that is instructing the DRV8703D-Q1 device is active and in a known state. The SPI watchdog must be enabled by writing a 1 to the WD_EN bit through the SPI (disabled by default, bit is 0). When the watchdog is enabled, an internal timer starts to count down to an interval set by the WD_DLY bits. The register address 0x00 must be read by the MCU within the interval set by the WD_DLY bit to reset the watchdog. If the timer is allowed to expire, the nWDFLT pin is enabled. When the nWDFLT pin is enabled the following occurs:

- The nWDFLT pin goes low for 64 μ s.
- The nFAULT pin is asserted.
- The WD_EN bit is cleared.
- The drivers are disabled.

The WDFLT bit remains asserted, and operation is halted until the CLR_FLT bit has been written to 1.

Table 8 lists the fault responses of the device under the fault conditions.

Table 8. Fault Response

| FAULT | CONDITION | HALF-BRIDGE | CHARGE PUMP | AVDD | DVDD | RECOVERY |
|-----------------------------|--------------------------------------------------------|-------------|-------------|-----------|-----------|---------------------------------------------------------------|
| VM undervoltage (UVLO) | $V_{VM} \leq V_{(UVLOx)}$ (5.45 V, max) | Disabled | Disabled | Disabled | Operating | $V_{VM} \geq V_{(UVLOx)}$ (5.65 V, max) |
| VCP undervoltage (CPUV) | $V_{VCP} \leq V_{(CP_UV)}$ ($V_{VM} + 1.5$, typ) | Disabled | Operating | Operating | Operating | $V_{VCP} \geq V_{(CP_UV)}$ ($V_{VM} + 1.5$, typ) |
| External FET overload (OCP) | $V_{DS} \geq V_{DS(OCP)}$ $V_{SP} - V_{SN} > 1$ V | Disabled | Operating | Operating | Operating | $t_{(RETRY)}$ |
| Gate driver fault (GDF) | Gate voltage unchanged after $t_{(DRIVE)}$ | Disabled | Operating | Operating | Operating | $t_{(RETRY)}$ |
| Watchdog fault (WDFLT) | Watchdog timer expires | Disabled | Operating | Operating | Operating | CLR_FLT bit |
| Thermal shutdown (TSD) | $T_J \geq T_{SD}$ (150°C, min) | Disabled | Disabled | Disabled | Operating | $T_J \leq T_{SD} - T_{hys}$ (T_{hys} is typically 20°C) |

7.3.14.8 Reverse Supply Protection

The circuit in [Figure 45](#) can be implemented to help protect the system from reverse supply conditions. This circuit requires the following additional components:

- NMOS FET
- NPN BJT
- Diode
- 10-k Ω resistor
- 43-k Ω resistor

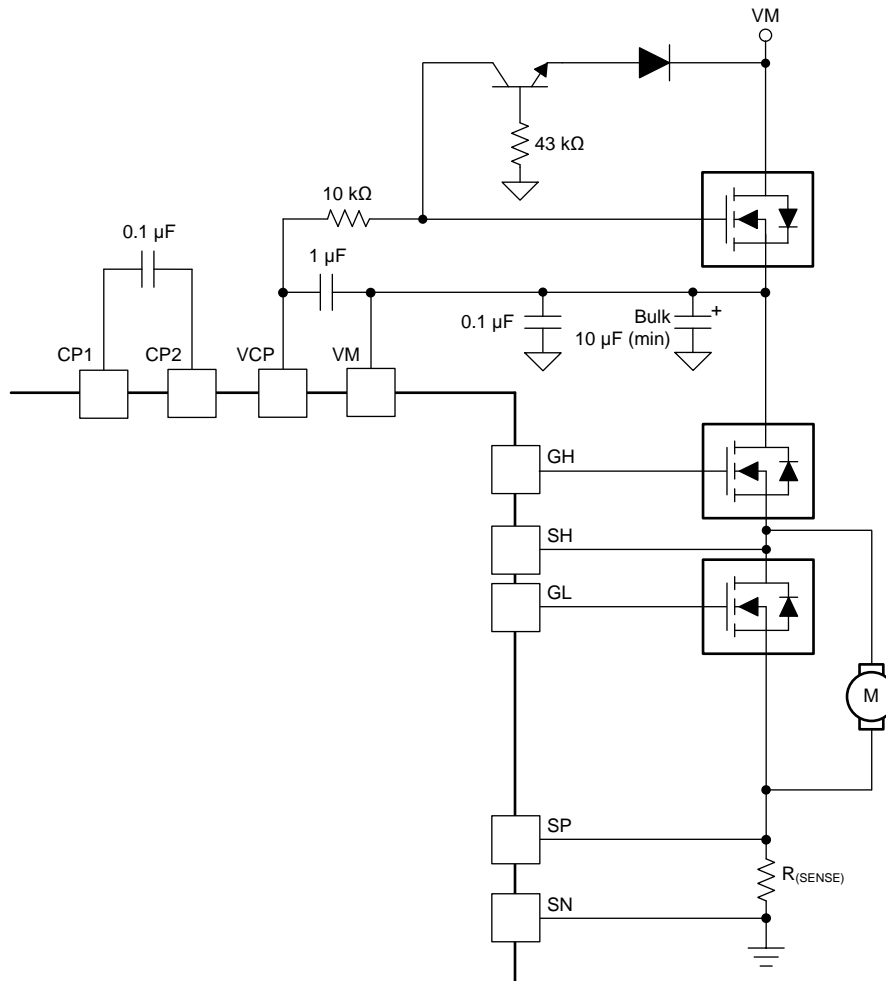

Figure 45. Reverse Supply Protection

7.3.15 Hardware Interface

The DRV8702D-Q1 hardware interface allows the device to be configured without a SPI, however not all of the functionality is configurable like the DRV8703D-Q1 device. The following configuration settings are fixed for the hardware-interface device option:

- The t_{off} value is set to 25 μ s.
- Current regulation is enabled
- The VREF pin voltage is not scaled internally (100%).
- The shunt amplifier has a fixed gain of 19.8 V/V.

7.3.15.1 IDRIVE (6-level input)

The voltage or resistance on the IDRIVE pin sets the peak source and peak sink IDRIVE setting as listed in [Table 9](#).

Table 9. DRV8702D-Q1 IDRIVE Settings

| IDRIVE RESISTANCE | IDRIVE VOLTAGE | SOURCE CURRENT | | SINK CURRENT | |
|--------------------------------|----------------|---------------------------------------|---------------------------------------|---------------------------------------|---------------------------------------|
| | | $V_{VM} = 5.5$ V | $V_{VM} = 13.5$ V | $V_{VM} = 5.5$ V | $V_{VM} = 13.5$ V |
| < 1 k Ω to GND | GND | High-side: 10 mA Low-side: 10 mA | High-side: 10 mA Low-side: 10 mA | High-side: 20 mA Low-side: 20 mA | High-side: 20 mA Low-side: 20 mA |
| 33 k Ω \pm 5% to GND | 0.7 V \pm 5% | High-side: 20 mA Low-side: 20 mA | High-side: 20 mA Low-side: 20 mA | High-side: 40 mA Low-side: 40 mA | High-side: 40 mA Low-side: 40 mA |
| 200 k Ω \pm 5% to GND | 2 V \pm 5% | High-side: 50 mA Low-side: 40 mA | High-side: 50 mA Low-side: 45 mA | High-side: 90 mA Low-side: 85 mA | High-side: 95 mA Low-side: 95 mA |
| > 2 M Ω to GND, Hi-Z | 3 V \pm 5% | High-side: 145 mA Low-side: 115 mA | High-side: 155 mA Low-side: 130 mA | High-side: 250 mA Low-side: 235 mA | High-side: 265 mA Low-side: 260 mA |
| 68 k Ω \pm 5% to AVDD | 4 V \pm 5% | High-side: 190 mA Low-side: 145 mA | High-side: 210 mA Low-side: 180 mA | High-side: 330 mA Low-side: 300 mA | High-side: 350 mA Low-side: 350 mA |
| < 1 k Ω to AVDD | AVDD | High-side: 240 mA Low-side: 190 mA | High-side: 260 mA Low-side: 225 mA | High-side: 420 mA Low-side: 360 mA | High-side: 440 mA Low-side: 430 mA |

7.3.15.2 VDS (6-Level Input)

This input controls the VDS monitor trip voltage as listed in [Table 10](#).

Table 10. DRV8702D-Q1 VDS Settings

| VDS RESISTANCE | VDS VOLTAGE | OVERCURRENT TRIP LEVEL ($V_{DS(OCF)}$) |
|--------------------------------|----------------|------------------------------------------|
| < 1 k Ω to GND | GND | 0.06 V |
| 33 k Ω \pm 5% to GND | 0.7 V \pm 5% | 0.12 V |
| 200 k Ω \pm 5% to GND | 2 V \pm 5% | 0.24 V |
| > 2 M Ω to GND, Hi-Z | 3 V \pm 5% | 0.48 V |
| 68 k Ω \pm 5% to AVDD | 4 V \pm 5% | 0.96 V |
| < 1 k Ω to AVDD | AVDD | Disabled |

7.4 Device Functional Modes

The DRV870xD-Q1 device is active unless the nSLEEP pin is brought low. In sleep mode, the charge pump is disabled, the half-bridge FETs are disabled to the Hi-Z state, and the AVDD and DVDD regulators are disabled.

NOTE

The $t_{(SLEEP)}$ time must elapse after a falling edge on the nSLEEP pin before the device is in sleep mode. The DRV870xD-Q1 device is brought out of sleep mode automatically if the nSLEEP pin is brought high.

The $t_{(WAKE)}$ time must elapse before the outputs change state after wakeup.

On the DRV8703D-Q1 device, the SPI settings are reset when coming out of UVLO or exiting sleep mode.

While the nSLEEP pin is brought low, both external half-bridge FETs are disabled. The high-side gate pin, GH, are pulled to the output node, SH, by an internal resistor and the low-side gate pin, GL, are pulled to ground.

When the VM voltage is not applied and during the power-on time (t_{on}) the outputs are disabled using weak pulldown resistors between the GH and SH pins and the GL and GND pins.

NOTE

The MODE pin controls the device-logic operation for phase and enable, independent half-bridge, or PWM input modes. This operation is latched on power up or when exiting sleep mode.

7.5 Programming

7.5.1 SPI Communication

7.5.1.1 Serial Peripheral Interface (SPI)

The SPI (DRV8703D-Q1 only) is used to set device configurations, operating parameters, and read out diagnostic information. The DRV8703D-Q1 SPI operates in slave mode. The SPI input data (SDI) word consists of a 16-bit word, with a 5-bit command, 3 don't care bits, and 8 bits of data. The SPI output data (SDO) word consists of 8-bit register data and the first 8 bits are don't cares.

A valid frame has to meet following conditions:

- The clock polarity (CPOL) must be set to 0.
- The clock phase (CPHA) must be set to 0.
- The SCLK pin must be low when the nSCS pin goes low and when the nSCS pin goes high.
- No SCLK signal can occur when the nSCS signal is in transition.
- The SCLK pin must be low when the nSCS pin goes high.
- The nSCS pin should be taken high for at least 500 ns between frames.
- When the nSCS pin is asserted high, any signals at the SCLK and SDI pins are ignored, and the SDO pin is in the high impedance state.
- Full 16 SCLK cycles must occur.
- Data is captured on the falling edge of the clock and data is driven on the rising edge of the clock.
- The most-significant bit (MSB) is shifted in and out first
- For a write command, if the data word sent to the SDI pin is less than or more than 16 bits, a frame error occurs and the data word is ignored.
- For a write command, the existing data in the register being written to is shifted out on the SDO pin following the 5-bit command data

Programming (continued)

7.5.1.2 SPI Format

The SDI input-data word is 16 bits long and consists of the following format:

- 1 read or write bit, W (bit 15)
- 4 address bits, A (bits 14 through 11)
- 3 don't care bits, X (10 through 8)
- 8 data bits, D (7:0)

The SDO output-data word is 16 bits long and the first 8 bits are don't care bits. The data word is the content of the register being accessed.

For a write command ($W0 = 0$), the response word on the SDO pin is the data currently in the register being written to.

For a read command ($W0 = 1$), the response word is the data currently in the register being read.

Table 11. SDI Input Data Word Format

| R/W | ADDRESS | | | | DON'T CARE | | | DATA | | | | | | | |
|-----|---------|-----|-----|-----|------------|----|----|------|----|----|----|----|----|----|----|
| B15 | B14 | B13 | B12 | B11 | B10 | B9 | B8 | B7 | B6 | B5 | B4 | B3 | B2 | B1 | B0 |
| W0 | A3 | A2 | A1 | A0 | X | X | X | D7 | D6 | D5 | D4 | D3 | D2 | D1 | D0 |

Table 12. SDO Output Data Word Format

| DON'T CARE | | | | | | | | DATA | | | | | | | |
|------------|-----|-----|-----|-----|-----|----|----|------|----|----|----|----|----|----|----|
| B15 | B14 | B13 | B12 | B11 | B10 | B9 | B8 | B7 | B6 | B5 | B4 | B3 | B2 | B1 | B0 |
| X | X | X | X | X | X | X | X | D7 | D6 | D5 | D4 | D3 | D2 | D1 | D0 |

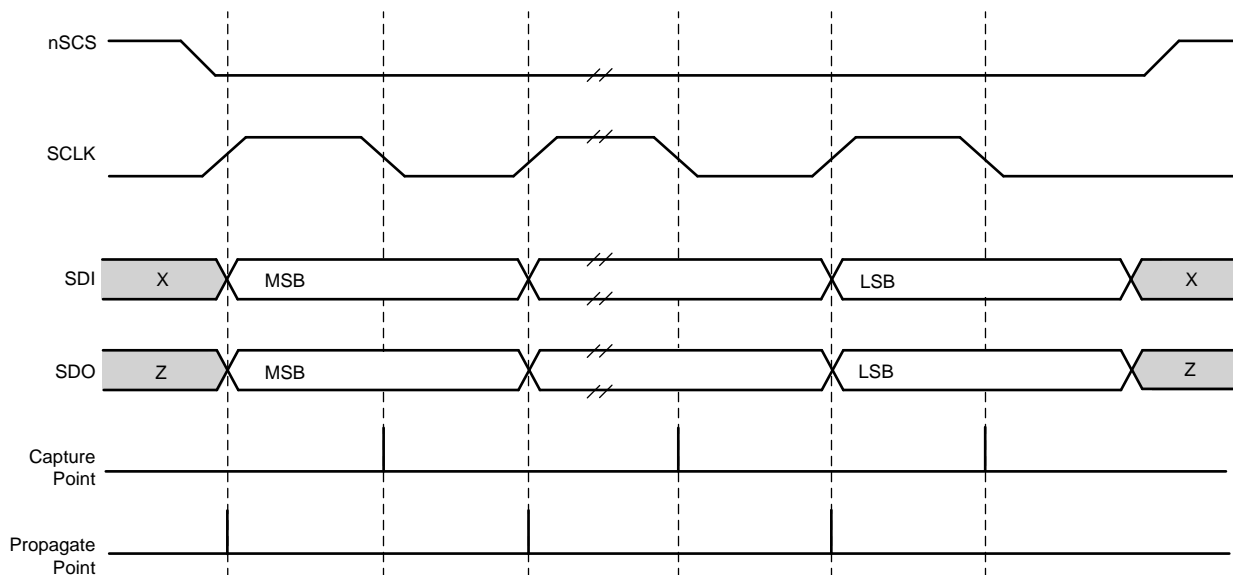

Figure 46. SPI Transaction

The SCLK pin should be low at power-up of the device for reliable SPI transaction. If the SCLK pin cannot be guaranteed to be low at power-up, TI recommends performing a dummy SPI-read transaction (of any register) after power-up to ensure reliable subsequent transactions. Data read from this dummy read transaction should be discarded.

7.6 Register Maps

DRV8703D-Q1 Memory Map

| Register Name | 7 | 6 | 5 | 4 | 3 | 2 | 1 | 0 | Access Type | Address (Hex) |
|---------------|----------|-------|----------|----------|----------|----------|-----------|-----------|-------------|---------------|
| FAULT Status | FAULT | WDFLT | GDF | OCF | VM_UVFL | VCP_UVFL | OTSD | OTW | R | 0 |
| VDS and GDF | RESERVED | | H_GDF | L_GDF | RESERVED | | H_VDS | L_VDS | R | 1 |
| Main | RESERVED | | LOCK | | | IN1 | IN2 | CLR_FLT | RW | 2 |
| IDRIVE and WD | TDEAD | | WD_EN | WD_DLY | | IDRIVE | | | RW | 3 |
| VDS | SO_LIM | VDS | | | RESERVED | | DIS_H_VDS | DIS_L_VDS | RW | 4 |
| Config | TOFF | | CHOP_IDS | VREF_SCL | | SH_EN | GAIN_CS | | RW | 5 |

Table 13. Access Type Codes

| Access Type | Code | Description |
|-------------------|------|-------------|
| Read Type | | |
| R | R | Read |
| Write Type | | |
| W | W | Write |

7.6.1 Status Registers

The status registers are used to report warning and fault conditions. Status registers are read only registers.

[Table 14](#) lists the memory-mapped registers for the status registers. All register offset addresses not listed in [Table 14](#) should be considered as reserved locations and the register contents should not be modified.

Table 14. Status Registers Summary Table

| Address | Register Name | Section |
|---------|--------------------|--------------------|
| 0x00h | FAULT status | Go |
| 0x01h | VDS and GDF status | Go |

7.6.1.1 FAULT Status Register (address = 0x00h)

FAULT status is shown in [Figure 47](#) and described in [Table 15](#).

Return to [Summary Table](#).

Read only

Figure 47. FAULT Status Register

| 7 | 6 | 5 | 4 | 3 | 2 | 1 | 0 |
|-------|-------|------|------|---------|----------|------|------|
| FAULT | WDFLT | GDF | OCF | VM_UVFL | VCP_UVFL | OTSD | OTW |
| R-0b | R-0b | R-0b | R-0b | R-0b | R-0b | R-0b | R-0b |

Table 15. FAULT Status Field Descriptions

| Bit | Field | Type | Default | Description |
|-----|----------|------|---------|-------------------------------------------------------------|
| 7 | FAULT | R | 0b | Logic OR of the FAULT status register excluding the OTW bit |
| 6 | WDFLT | R | 0b | Watchdog time-out fault |
| 5 | GDF | R | 0b | Indicates gate drive fault condition |
| 4 | OCF | R | 0b | Indicates VDS monitor overcurrent fault condition |
| 3 | VM_UVFL | R | 0b | Indicates VM undervoltage lockout fault condition |
| 2 | VCP_UVFL | R | 0b | Indicates charge-pump undervoltage fault condition |
| 1 | OTSD | R | 0b | Indicates overtemperature shutdown |
| 0 | OTW | R | 0b | Indicates overtemperature warning |

7.6.1.2 VDS and GDF Status Register Name (address = 0x01h)

VDS and GDF status is shown in [Figure 48](#) and described in [Table 16](#).

Return to [Summary Table](#).

Read only

Figure 48. VDS and GDF Status Register

| 7 | 6 | 5 | 4 | 3 | 2 | 1 | 0 |
|----------|---|-------|-------|----------|---|-------|-------|
| RESERVED | | H_GDF | L_GDF | RESERVED | | H_VDS | L_VDS |
| R-00b | | R-0b | R-0b | R-00b | | R-0b | R-0b |

Table 16. VDS and GDF Status Field Descriptions

| Bit | Field | Type | Default | Description |
|-----|----------|------|---------|-----------------------------------------------------------------------------|
| 7-6 | RESERVED | R | 00b | Reserved |
| 5 | H_GDF | R | 0b | Indicates gate drive fault on the high-side FET of half-bridge |
| 4 | L_GDF | R | 0b | Indicates gate drive fault on the low-side FET of half-bridge |
| 3-2 | RESERVED | R | 00b | Reserved |
| 1 | H_VDS | R | 0b | Indicates VDS monitor overcurrent fault on the high-side FET of half-bridge |
| 0 | L_VDS | R | 0b | Indicates VDS monitor overcurrent fault on the low-side FET of half-bridge |

7.6.2 Control Registers

The control registers are used to configure the device. Control registers are read and write capable.

[Table 17](#) lists the memory-mapped registers for the status registers. All register offset addresses not listed in [Table 17](#) should be considered as reserved locations and the register contents should not be modified.

Table 17. Status Registers Summary Table

| Address | Register Name | Section |
|---------|-----------------------|--------------------|
| 0x02h | Main control | Go |
| 0x03h | IDRIVE and WD control | Go |
| 0x04h | VDS control | Go |
| 0x05h | Config control | Go |

7.6.2.1 Main Control Register Name (address = 0x02h)

Main control is shown in [Figure 49](#) and described in [Table 18](#).

Return to [Summary Table](#).

Read and write

Figure 49. Main Control Register

| 7 | 6 | 5 | 4 | 3 | 2 | 1 | 0 |
|----------|---|----------|---|---|--------|--------|---------|
| RESERVED | | LOCK | | | IN1 | IN2 | CLR_FLT |
| R/W-00b | | R/W-011b | | | R/W-0b | R/W-0b | R/W-0b |

Table 18. Main Control Field Descriptions

| Bit | Field | Type | Default | Description |
|-----|----------|------|---------|-----------------------------------------------------------------------------------------------------------------------------------------------------------------------------------------------------------------------------------------------------------------------------------------|
| 7-6 | RESERVED | R/W | 00b | Reserved |
| 5-3 | LOCK | R/W | 011b | Write 110b to lock the settings by ignoring further register changes except to address 0x02h. Writing any sequence other than 110b has no effect when unlocked. Write 011b to this register to unlock all registers. Writing any sequence other than 011b has no effect when locked. |
| 2 | IN1 | R/W | 0b | This bit is ORed with the IN1 pin |
| 1 | IN2 | R/W | 0b | This bit is ORed with the IN2 pin |
| 0 | CLR_FLT | R/W | 0b | Write a 1 to this bit to clear the fault bits |

7.6.2.2 IDRIVE and WD Control Register Name (address = 0x03h)

 IDRIVE and WD control is shown in [Figure 50](#) and described in [Table 19](#).

 Return to [Summary Table](#).

Read and write

Figure 50. IDRIVE and WD Register

| 7 | 6 | 5 | 4 | 3 | 2 | 1 | 0 |
|---------|---|--------|---------|---|----------|---|---|
| TDEAD | | WD_EN | WD_DLY | | IDRIVE | | |
| R/W-00b | | R/W-0b | R/W-00b | | R/W-111b | | |

Table 19. IDRIVE and WD Field Descriptions

| Bit | Field | Type | Default | Description |
|-----|--------|------|---------|---------------------------------------------------------------------------------------------------------------------------|
| 7-6 | TDEAD | R/W | 00b | Dead time 00b = 120 ns 01b = 240 ns 10b = 480 ns 11b = 960 ns |
| 5 | WD_EN | R/W | 0b | Time-out of the watchdog timer |
| 4-3 | WD_DLY | R/W | 00b | Enables or disables the watchdog timer (disabled by default) 00b = 10 ms 01b = 20 ms 10b = 50 ms 11b = 100 ms |
| 2-0 | IDRIVE | R/W | 111b | Sets the peak source current and peak sink current of the gate drive. Table 20 lists the bit settings. |

Table 20. IDRIVE Bit Settings

| Bit Value | Source Current | | Sink Current | |
|-----------|---------------------------------------|---------------------------------------|---------------------------------------|---------------------------------------|
| | V _{VM} = 5.5 V | V _{VM} = 13.5 V | V _{VM} = 5.5 V | V _{VM} = 13.5 V |
| 000b | High-side: 10 mA Low-side: 10 mA | High-side: 10 mA Low-side: 10 mA | High-side: 20 mA Low-side: 20 mA | High-side: 20 mA Low-side: 20 mA |
| 001b | High-side: 20 mA Low-side: 20 mA | High-side: 20 mA Low-side: 20 mA | High-side: 40 mA Low-side: 40 mA | High-side: 40 mA Low-side: 40 mA |
| 010b | High-side: 50 mA Low-side: 40 mA | High-side: 50 mA Low-side: 45 mA | High-side: 90 mA Low-side: 85 mA | High-side: 95 mA Low-side: 95 mA |
| 011b | High-side: 70 mA Low-side: 55 mA | High-side: 70 mA Low-side: 60 mA | High-side: 120 mA Low-side: 115 mA | High-side: 130 mA Low-side: 125 mA |
| 100b | High-side: 100 mA Low-side: 75 mA | High-side: 105 mA Low-side: 90 mA | High-side: 170 mA Low-side: 160 mA | High-side: 185 mA Low-side: 180 mA |
| 101b | High-side: 145 mA Low-side: 115 mA | High-side: 155 mA Low-side: 130 mA | High-side: 250 mA Low-side: 235 mA | High-side: 265 mA Low-side: 260 mA |
| 110b | High-side: 190 mA Low-side: 145 mA | High-side: 210 mA Low-side: 180 mA | High-side: 330 mA Low-side: 300 mA | High-side: 350 mA Low-side: 350 mA |
| 111b | High-side: 240 mA Low-side: 190 mA | High-side: 260 mA Low-side: 225 mA | High-side: 420 mA Low-side: 360 mA | High-side: 440 mA Low-side: 430 mA |

7.6.2.3 VDS Control Register Name (address = 0x04h)

VDS control is shown in [Figure 51](#) and described in [Table 21](#).

Return to [Summary Table](#).

Read and write

Figure 51. VDS Control Register

| 7 | 6 | 5 | 4 | 3 | 2 | 1 | 0 |
|--------|----------|---|---|----------|---|-----------|-----------|
| SO_LIM | VDS | | | RESERVED | | DIS_H_VDS | DIS_L_VDS |
| R/W-0b | R/W-111b | | | R-00b | | R/W-0b | R/W-0b |

Table 21. VDS Control Field Descriptions

| Bit | Field | Type | Default | Description |
|-----|-----------|------|---------|------------------------------------------------------------------------------------------------------------------------------------------------------------------------------------|
| 7 | SO_LIM | R/W | 0b | 0b = Default operation 1b = SO output is voltage-limited to 3.6 V |
| 6-4 | VDS | R/W | 111b | Sets the $V_{DS(OC)}$ monitor for each FET 000b = 0.06 V 001b = 0.145 V 010b = 0.17 V 011b = 0.2 V 100b = 0.12 V 101b = 0.24 V 110b = 0.48 V 111b = 0.96 V |
| 3-2 | RESERVED | R | 00b | Reserved |
| 1 | DIS_H_VDS | R/W | 0b | Disables the VDS monitor on the high-side FET of half-bridge (enabled by default) |
| 0 | DIS_L_VDS | R/W | 0b | Disables the VDS monitor on the low-side FET of half-bridge (enabled by default) |

7.6.2.4 Config Control Register Name (address = 0x05h)

Config control is shown in [Figure 52](#) and described in [Table 22](#).

Return to [Summary Table](#).

Read and write

Figure 52. Config Control Register

| 7 | 6 | 5 | 4 | 3 | 2 | 1 | 0 |
|---------|---|----------|----------|---|--------|---------|---|
| TOFF | | CHOP_IDS | VREF_SCL | | SH_EN | GAIN_CS | |
| R/W-00b | | R/W-0b | R/W-00b | | R/W-0b | R/W-01b | |

Table 22. Config Control Field Descriptions

| Bit | Field | Type | Default | Description |
|-----|----------|------|---------|---------------------------------------------------------------------------------------------------------------------|
| 7-6 | TOFF | R/W | 00b | Off time for PWM current chopping 00b = 25 μ s 01b = 50 μ s 10b = 100 μ s 11b = 200 μ s |
| 5 | CHOP_IDS | R/W | 0b | Disables current regulation (enabled by default) |
| 4-3 | VREF_SCL | R/W | 00b | Scale factor for the VREF input 00b = 100% 01b = 75% 10b = 50% 11b = 25% |
| 2 | SH_EN | R/W | 0b | Enables sample and hold operation of the shunt amplifier (disabled by default) |
| 1-0 | GAIN_CS | R/W | 01b | Shunt amplifier gain setting 00b = 10 V/V 01b = 19.8 V/V 10b = 39.4 V/V 11b = 78 V/V |

8 Application and Implementation

NOTE

Information in the following applications sections is not part of the TI component specification, and TI does not warrant its accuracy or completeness. TI's customers are responsible for determining suitability of components for their purposes. Customers should validate and test their design implementation to confirm system functionality.

8.1 Application Information

The DRV870xD-Q1 device is used in brushed-DC, solenoid, or relay-control applications. The following typical application can be used to configure the DRV870xD-Q1 device.

8.2 Typical Application

This application features the DRV8702D-Q1 device.

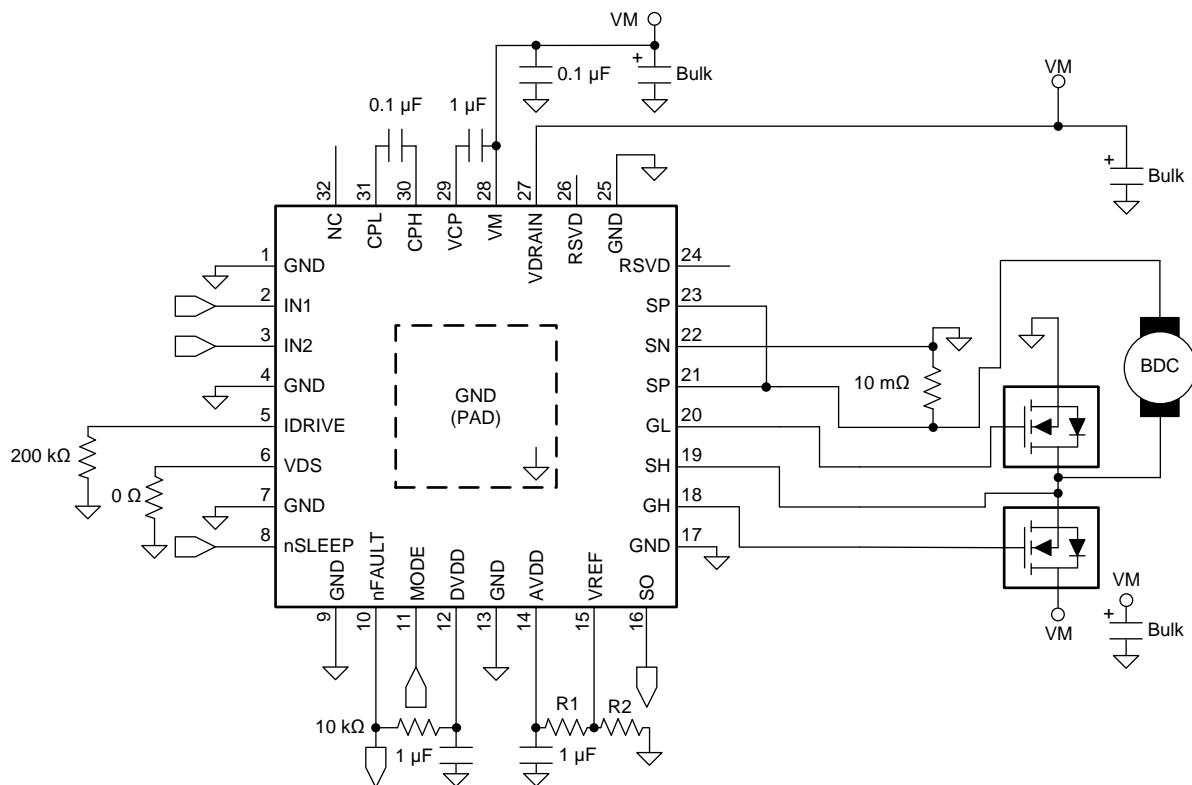

Copyright © 2017, Texas Instruments Incorporated

Figure 53. DRV8702D-Q1 Typical Application Schematic

Typical Application (continued)

8.2.1 Design Requirements

For this design example, use the parameters listed in [Table 23](#) as the input parameters.

Table 23. Design Parameters

| DESIGN PARAMETER | REFERENCE | EXAMPLE VALUE |
|------------------------------|--------------|------------------|
| Nominal supply voltage | VM | 14 V |
| Supply voltage range | | 7 V to 35 V |
| FET part number | | CSD18502Q5B |
| FET total gate charge | Q_g | 52 nC (typical) |
| FET gate-to-drain charge | Q_{gd} | 8.4 nC (typical) |
| Target FET gate rise time | t_r | 100 to 300 ns |
| Motor current chopping level | $I_{(CHOP)}$ | 15 A |

8.2.2 Detailed Design Procedure

8.2.2.1 External FET Selection

The DRV8702D-Q1 FET support is based on the charge-pump capacity and PWM-output frequency. For a quick calculation of FET driving capacity, use [Equation 3](#) when drive and brake (slow decay) are the primary modes of operation.

$$Q_g < \frac{I_{VCP}}{f_{(PWM)}}$$

where

- f_{PWM} is the maximum desired PWM frequency to be applied to the DRV8702D-Q1 inputs or the current chopping frequency, whichever is larger.
- I_{VCP} is the charge-pump capacity, which depends on the VM voltage.

The internal current chopping frequency is at most equal to the PWM frequency as shown in [Equation 4](#).

$$f_{(PWM)} < \frac{1}{t_{off} + t_{(BLANK)}}$$

For example, if the VM voltage of a system is 7 V ($I_{VCP} = 8$ mA) and uses a maximum PWM frequency of 40 kHz, then the DRV8702D-Q1 device will support FETs with a Q_g up to 200 nC.

If the application requires a forced fast decay (or alternating between drive and reverse drive), use [Equation 5](#) to calculate the maximum FET driving capacity.

$$Q_g < \frac{I_{VCP}}{2 \times f_{(PWM)}}$$

8.2.2.2 IDRIVE Configuration

The IDRIVE current is selected based on the gate charge of the FETs. The IDRIVE pin must be configured so that the FET gates are charged entirely during the $t_{(DRIVE)}$ time. If the selected IDRIVE current is too low for a given FET, then the FET may not turn on completely. TI recommends adjusting these values in-system with the required external FETs and motor to determine the best possible setting for any application.

For FETs with a known gate-to-drain charge (Q_{gd}) and desired rise time (t_r), the IDRIVE current can be selected based on the [Equation 6](#).

$$I_{DRIVE} > \frac{Q_{gd}}{t_r}$$

If the gate-to-drain charge is 2.3 nC and the desired rise time is around 100 to 300 ns, use [Equation 7](#) to calculate the minimum IDRIVE (I_{DRIVE1}) and [Equation 8](#) to calculate the maximum IDRIVE (I_{DRIVE2}).

$$I_{DRIVE1} = 8.4 \text{ nC} / 100 \text{ ns} = 84 \text{ mA} \quad (7)$$

$$I_{DRIVE2} = 8.4 \text{ nC} / 300 \text{ ns} = 28 \text{ mA} \quad (8)$$

Select a value for IDRIVE between 28 and 84 mA. An IDRIVE value of approximately 50 mA for the source (approximately 100 mA sink) was selected for this application. This value requires a 200-k Ω resistor from the IDRIVE pin to ground.

8.2.2.3 VDS Configuration

The VDS monitor is configured based on the maximum current and $R_{DS(on)}$ of the FETs. The VDS pin of the DRV8702D-Q1 selects the VDS monitor trip threshold. Use [Equation 3](#) to calculate the trip current.

$$I_{VDS} > \frac{V_{VDS}}{R_{DS(on)}} \quad (9)$$

If the $R_{DS(on)}$ of the FET is 1.8 m Ω and the desired VDS trip is less than 100 A, the V_{VDS} voltage is equal to 180 mV as shown in [Equation 10](#).

$$V_{VDS} = I_{VDS} \times R_{DS(on)} = 100 \text{ A} \times 1.8 \text{ m}\Omega = 180 \text{ mV} \quad (10)$$

Select a value for the VDS voltage that less than 180 mV. A V_{VDS} value of 0.12 V was selected for this application. This value requires tying the VDS pin to ground.

8.2.2.4 Current Chopping Configuration

The chopping current is set based on the sense resistor value and the analog voltage at the VREF pin. Use [Equation 11](#) to calculate the current ($I_{(CHOP)}$). The amplifier gain, A_V , is 19.8 V/V for the DRV8702D-Q1 and V_{IO} is typically 2.5 mV (input referred).

$$I_{(CHOP)} = \frac{V_{VREF} - V_{IO}}{A_V \times R_{(SENSE)}} \quad (11)$$

For example, if the desired chopping current is 15 A, select a value of 10 m Ω for $R_{(SENSE)}$. The value of V_{VREF} must therefore be 3.05 V. Add a resistor divider from the AVDD (5 V) pin to set the V_{VREF} at approximately 3.05 V. Select a value of 13 k Ω for and 20 k Ω for R1.

8.2.3 Application Curves

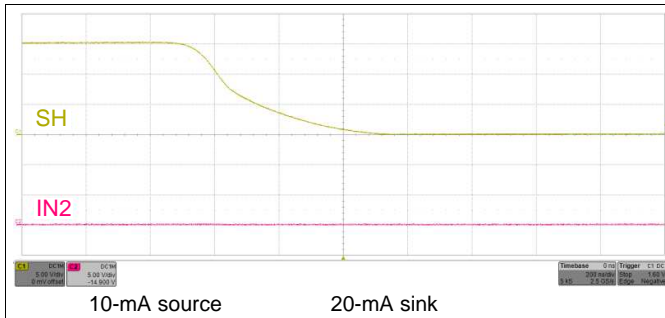

Figure 54. SH Fall Time

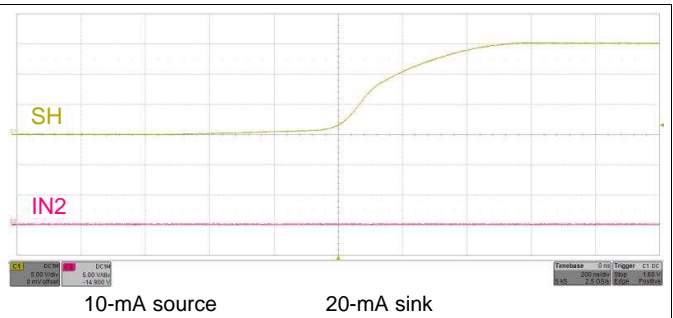

Figure 55. SH Rise Time

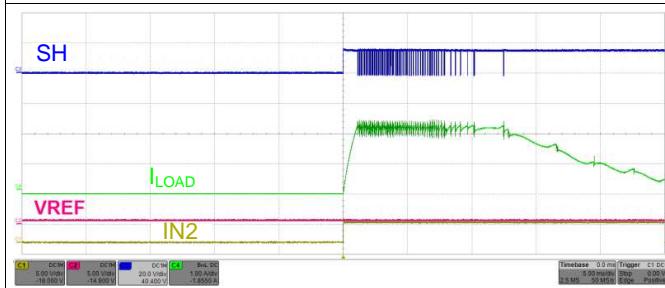

Figure 56. Current Profile on Motor Startup With Regulation

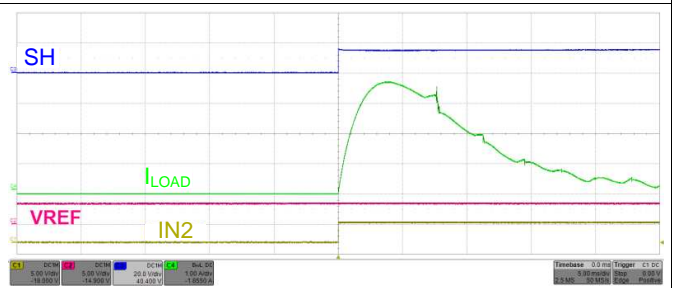

Figure 57. Current Profile on Motor Startup Without Regulation

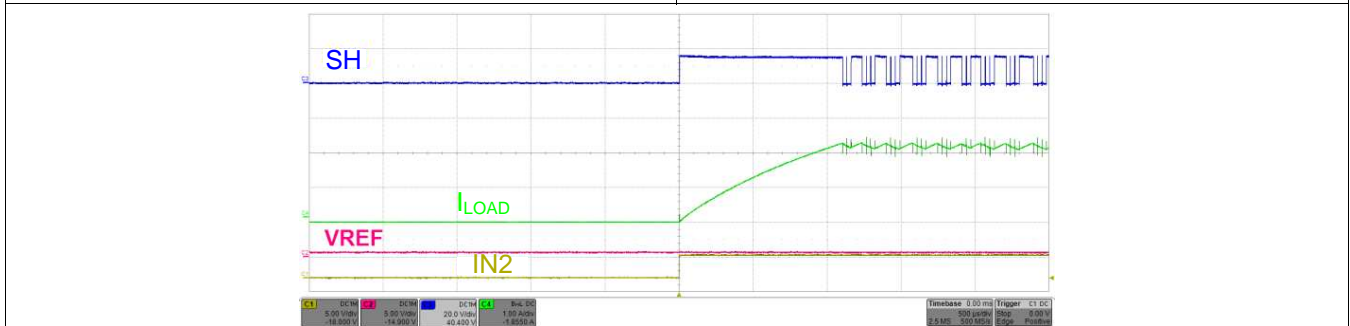

Figure 58. Current Regulating at 2.25 A on Motor Startup

9 Power Supply Recommendations

The DRV8702D-Q1 device is designed to operate with an input voltage supply (VM) range from 5.5 V to 45 V. A 0.1- μ F ceramic capacitor rated for VM must be placed as close to the DRV8702D-Q1 device as possible. Also, a bulk capacitor valued at least 10 μ F must be placed on the VM pin.

Additional bulk capacitance is required to bypass the external half-bridge FETs.

9.1 Bulk Capacitance Sizing

Bulk capacitance sizing is an important factor in motor drive system design. It is beneficial to have more bulk capacitance, while the disadvantages are increased cost and physical size.

The amount of local capacitance needed depends on a variety of factors including:

- The highest current required by the motor system.
- The capacitance of the power supply and the ability of the power supply to source current.
- The amount of parasitic inductance between the power supply and motor system.
- The acceptable voltage ripple.
- The type of motor used (brushed DC, brushless DC, and stepper).
- The motor braking method.

The inductance between the power supply and motor drive system limits the rate that current can change from the power supply. If the local bulk capacitance is too small, the system responds to excessive current demands or dumps from the motor with a change in voltage. When sufficient bulk capacitance is used, the motor voltage remains stable, and high current can be quickly supplied.

The data sheet provides a recommended value, but system-level testing is required to determine the appropriate sized bulk capacitor.

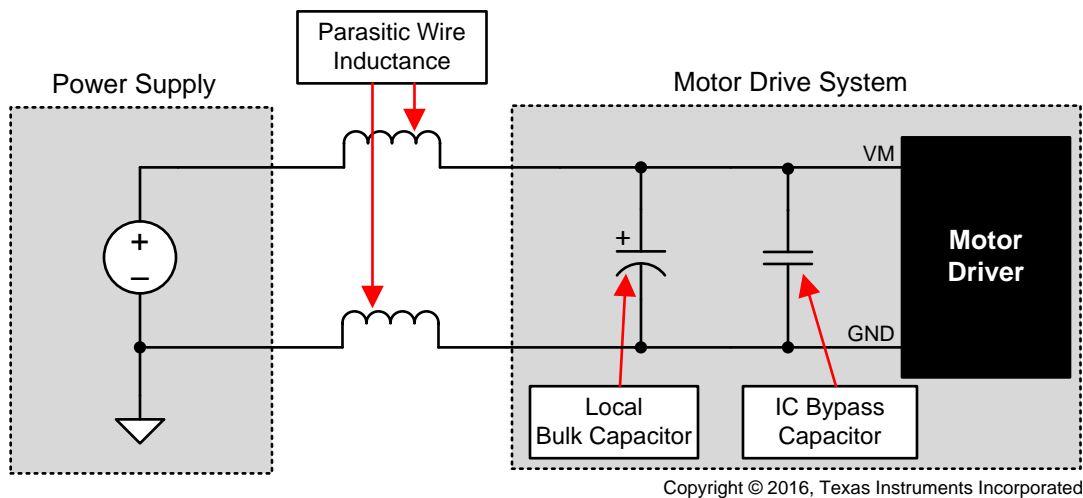

Figure 59. Example Setup of Motor Drive System With External Power Supply

The voltage rating for bulk capacitors should be higher than the operating voltage to provide a margin for cases when the motor transfers energy to the supply.

10 Layout

10.1 Layout Guidelines

The VM pin should be bypassed to ground using a low-ESR ceramic bypass capacitor with a recommended value of 0.1 μF rated for VM. This capacitor should be placed as close to the VM pin as possible with a thick trace or ground-plane connection to the GND pin of the device. The VM pin must also be bypassed to ground using a bulk capacitor rated for VM. This capacitor can be electrolytic and must be at least 10 μF .

A low-ESR ceramic capacitor must be placed between the CPL and CPH pins. A value of 0.1 μF rated for VM is recommended. Place this capacitor as close to the pins as possible. A low-ESR ceramic capacitor must be placed in between the VM and VCP pins. A value of 1 μF rated for 16 V is recommended. Place this component as close to the pins as possible.

Bypass the AVDD and DVDD pins to ground with ceramic capacitors rated for 6.3 V. Place these bypassing capacitors as close to the pins as possible.

Use separate traces to connect the SP and SN pins to the $R_{(\text{SENSE})}$ resistor.

10.2 Layout Example

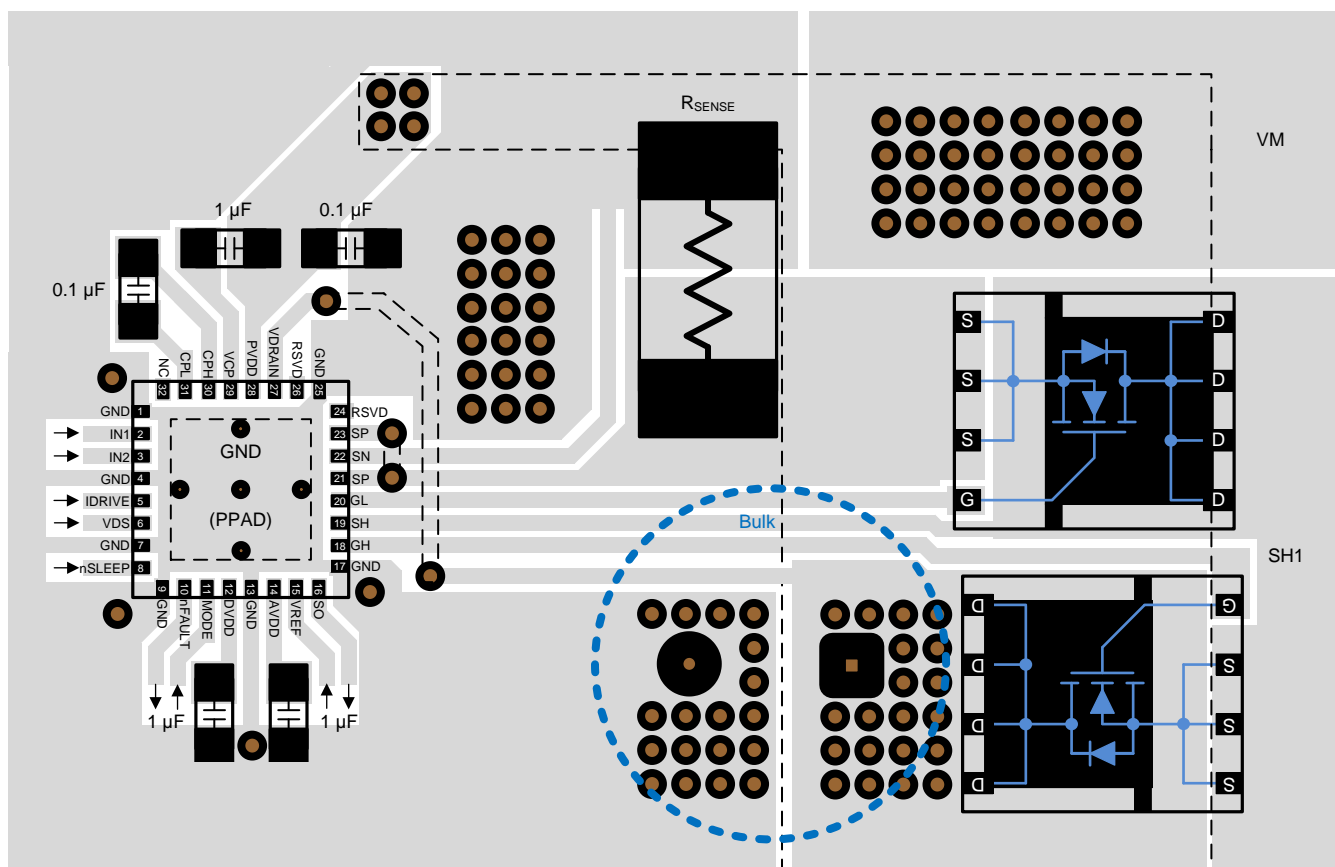

Figure 60. DRV8702D-Q1 Layout Example

11 Device and Documentation Support

11.1 Documentation Support

11.1.1 Related Documentation

For related documentation see the following:

- [Driving a Unidirectional Brushed DC Motor With Smart Gate Drive](#)
- [DRV8702-Q1 EVM User's Guide](#)
- [DRV8703-Q1 EVM User's Guide](#)
- [Small Footprint Motor Driver Sunroof Module Design Guide](#)

11.2 Related Links

The table below lists quick access links. Categories include technical documents, support and community resources, tools and software, and quick access to sample or buy.

Table 24. Related Links

| PARTS | PRODUCT FOLDER | ORDER NOW | TECHNICAL DOCUMENTS | TOOLS & SOFTWARE | SUPPORT & COMMUNITY |
|-------------|----------------------------|----------------------------|----------------------------|----------------------------|----------------------------|
| DRV8702D-Q1 | Click here | Click here | Click here | Click here | Click here |
| DRV8703D-Q1 | Click here | Click here | Click here | Click here | Click here |

11.3 Receiving Notification of Documentation Updates

To receive notification of documentation updates, navigate to the device product folder on ti.com. In the upper right corner, click on *Alert me* to register and receive a weekly digest of any product information that has changed. For change details, review the revision history included in any revised document.

11.4 Community Resources

The following links connect to TI community resources. Linked contents are provided "AS IS" by the respective contributors. They do not constitute TI specifications and do not necessarily reflect TI's views; see TI's [Terms of Use](#).

TI E2E™ Online Community *TI's Engineer-to-Engineer (E2E) Community*. Created to foster collaboration among engineers. At e2e.ti.com, you can ask questions, share knowledge, explore ideas and help solve problems with fellow engineers.

Design Support *TI's Design Support* Quickly find helpful E2E forums along with design support tools and contact information for technical support.

11.5 Trademarks

E2E is a trademark of Texas Instruments.
All other trademarks are the property of their respective owners.

11.6 Electrostatic Discharge Caution



This integrated circuit can be damaged by ESD. Texas Instruments recommends that all integrated circuits be handled with appropriate precautions. Failure to observe proper handling and installation procedures can cause damage.

ESD damage can range from subtle performance degradation to complete device failure. Precision integrated circuits may be more susceptible to damage because very small parametric changes could cause the device not to meet its published specifications.

11.7 Glossary

SLYZ022 — *TI Glossary*.

This glossary lists and explains terms, acronyms, and definitions.

12 Mechanical, Packaging, and Orderable Information

The following pages include mechanical, packaging, and orderable information. This information is the most current data available for the designated devices. This data is subject to change without notice and revision of this document. For browser-based versions of this data sheet, refer to the left-hand navigation.

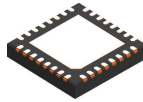

RHB0032N

PACKAGE OUTLINE
VQFN - 0.9 mm max height

PLASTIC QUAD FLATPACK - NO LEAD

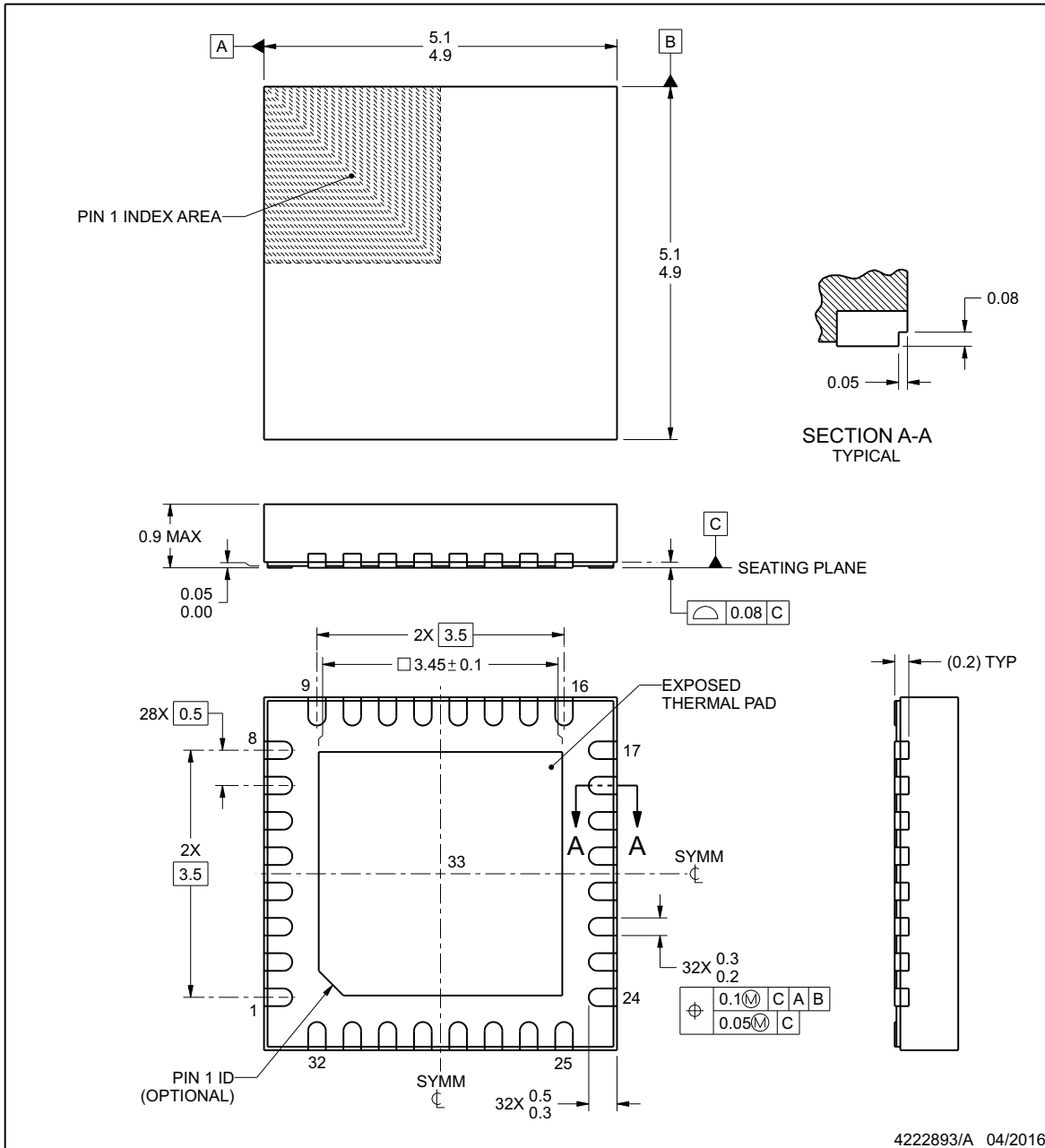

NOTES:

1. All linear dimensions are in millimeters. Any dimensions in parenthesis are for reference only. Dimensioning and tolerancing per ASME Y14.5M.
2. This drawing is subject to change without notice.
3. The package thermal pad must be soldered to the printed circuit board for thermal and mechanical performance.

EXAMPLE BOARD LAYOUT

RHB0032N

VQFN - 0.9 mm max height

PLASTIC QUAD FLATPACK - NO LEAD

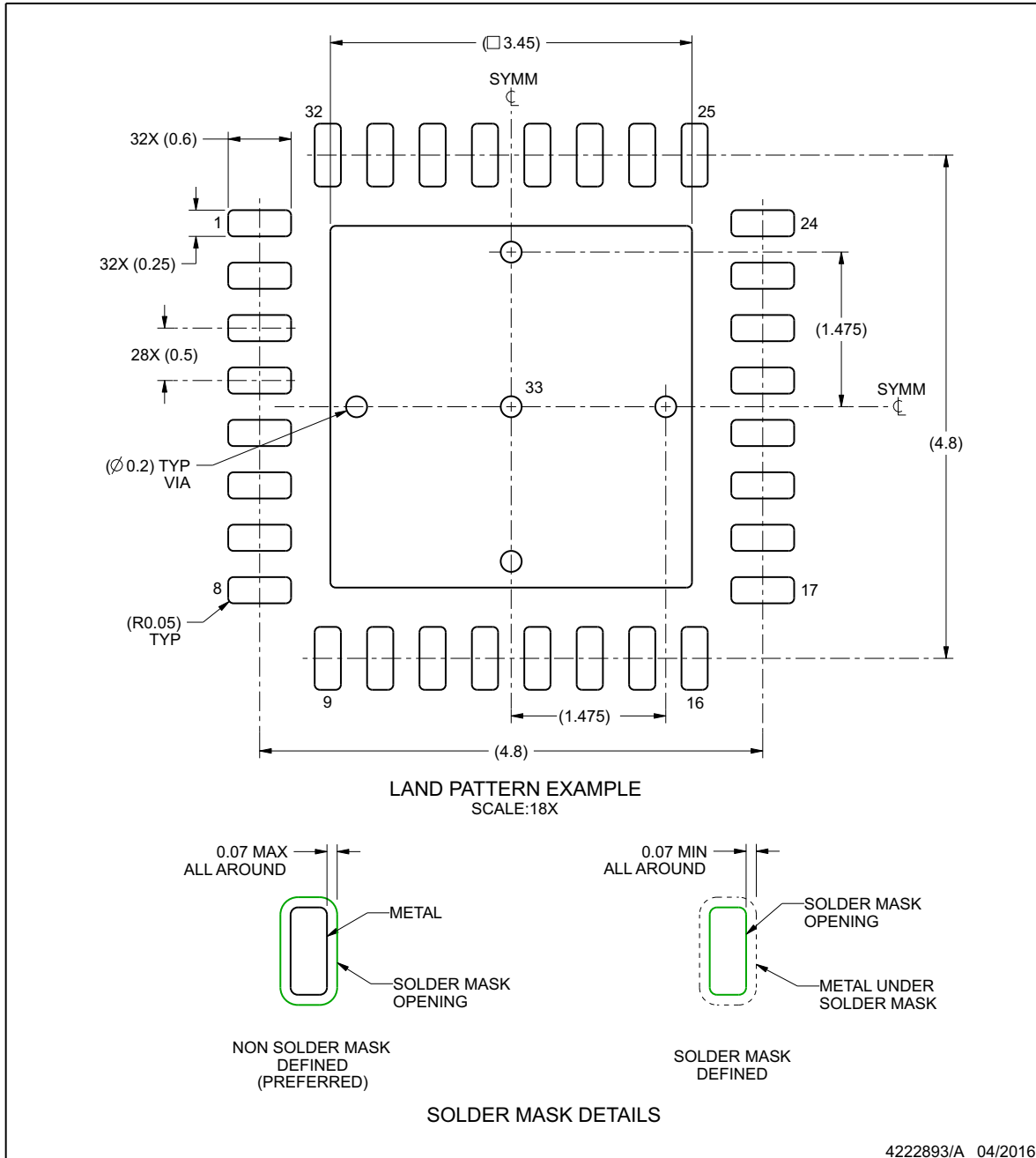

NOTES: (continued)

4. This package is designed to be soldered to a thermal pad on the board. For more information, see Texas Instruments literature number SLUA271 (www.ti.com/lit/sluea271).
5. Vias are optional depending on application, refer to device data sheet. If any vias are implemented, refer to their locations shown on this view. It is recommended that vias under paste be filled, plugged or tented.

EXAMPLE STENCIL DESIGN

RHB0032N

VQFN - 0.9 mm max height

PLASTIC QUAD FLATPACK - NO LEAD

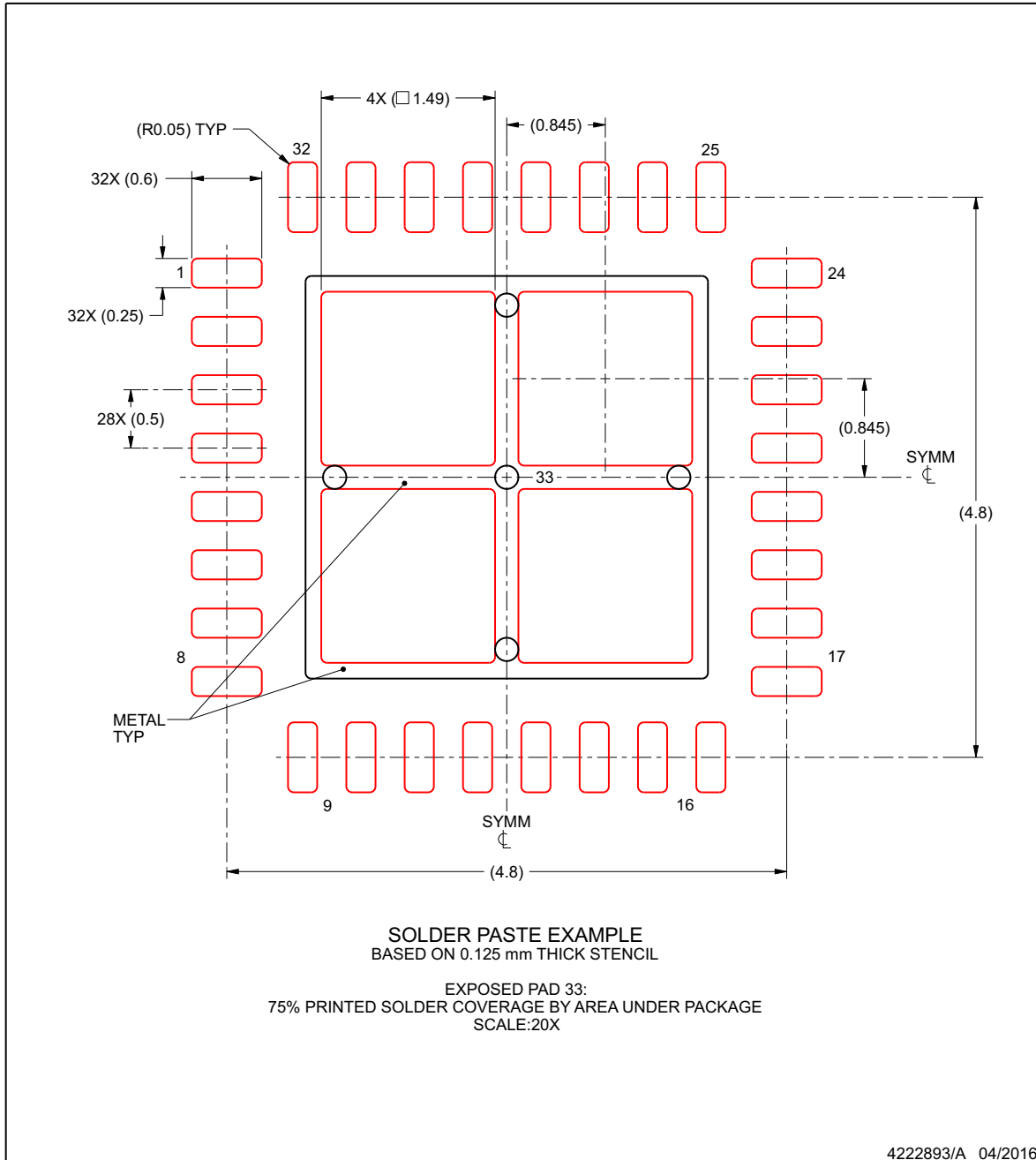

NOTES: (continued)

6. Laser cutting apertures with trapezoidal walls and rounded corners may offer better paste release. IPC-7525 may have alternate design recommendations.

12.1 Package Option Addendum

12.1.1 Packaging Information

| Orderable Device | Status ⁽¹⁾ | Package Type | Package Drawing | Pins | Package Qty | Eco Plan ⁽²⁾ | Lead/Ball Finish ⁽³⁾ | MSL Peak Temp ⁽⁴⁾ | Op Temp (°C) | Device Marking ⁽⁵⁾⁽⁶⁾ |
|------------------|-----------------------|--------------|-----------------|------|-------------|-------------------------|---------------------------------|------------------------------|--------------|----------------------------------|
| DRV8702DQRHBRQ1 | PREVIEW | VQFN | RHB | 32 | 3000 | Green (RoHS & no Sb/Br) | CU SN | Level-3-260C-168 HR | -40 to 125 | |
| DRV8702DQRHBTQ1 | PREVIEW | VQFN | RHB | 32 | 250 | Green (RoHS & no Sb/Br) | CU SN | Level-3-260C-168 HR | -40 to 125 | |
| DRV8703DQRHBRQ1 | PREVIEW | VQFN | RHB | 32 | 3000 | Green (RoHS & no Sb/Br) | CU SN | Level-3-260C-168 HR | -40 to 125 | |
| DRV8703DQRHBTQ1 | PREVIEW | VQFN | RHB | 32 | 250 | Green (RoHS & no Sb/Br) | CU SN | Level-3-260C-168 HR | -40 to 125 | |

(1) The marketing status values are defined as follows:

ACTIVE: Product device recommended for new designs.

LIFEBUY: TI has announced that the device will be discontinued, and a lifetime-buy period is in effect.

NRND: Not recommended for new designs. Device is in production to support existing customers, but TI does not recommend using this part in a new design.

PRE_PROD Unannounced device, not in production, not available for mass market, nor on the web, samples not available.

PREVIEW: Device has been announced but is not in production. Samples may or may not be available.

OBSOLETE: TI has discontinued the production of the device.

(2) Eco Plan - The planned eco-friendly classification: Pb-Free (RoHS), Pb-Free (RoHS Exempt), or Green (RoHS & no Sb/Br) - please check <http://www.ti.com/productcontent> for the latest availability information and additional product content details.

TBD: The Pb-Free/Green conversion plan has not been defined.

Pb-Free (RoHS): TI's terms "Lead-Free" or "Pb-Free" mean semiconductor products that are compatible with the current RoHS requirements for all 6 substances, including the requirement that lead not exceed 0.1% by weight in homogeneous materials. Where designed to be soldered at high temperatures, TI Pb-Free products are suitable for use in specified lead-free processes.

Pb-Free (RoHS Exempt): This component has a RoHS exemption for either 1) lead-based flip-chip solder bumps used between the die and package, or 2) lead-based die adhesive used between the die and leadframe. The component is otherwise considered Pb-Free (RoHS compatible) as defined above.

Green (RoHS & no Sb/Br): TI defines "Green" to mean Pb-Free (RoHS compatible), and free of Bromine (Br) and Antimony (Sb) based flame retardants (Br or Sb do not exceed 0.1% by weight in homogeneous material)

(3) Lead/Ball Finish - Orderable Devices may have multiple material finish options. Finish options are separated by a vertical ruled line. Lead/Ball Finish values may wrap to two lines if the finish value exceeds the maximum column width.

(4) MSL, Peak Temp. -- The Moisture Sensitivity Level rating according to the JEDEC industry standard classifications, and peak solder temperature.

(5) There may be additional marking, which relates to the logo, the lot trace code information, or the environmental category on the device

(6) Multiple Device markings will be inside parentheses. Only on Device Marking contained in parentheses and separated by a "~" will appear on a device. If a line is indented then it is a continuation of the previous line and the two combined represent the entire Device Marking for that device.

Important Information and Disclaimer: The information provided on this page represents TI's knowledge and belief as of the date that it is provided. TI bases its knowledge and belief on information provided by third parties, and makes no representation or warranty as to the accuracy of such information. Efforts are underway to better integrate information from third parties. TI has taken and continues to take reasonable steps to provide representative and accurate information but may not have conducted destructive testing or chemical analysis on incoming materials and chemicals. TI and TI suppliers consider certain information to be proprietary, and thus CAS numbers and other limited information may not be available for release.

In no event shall TI's liability arising out of such information exceed the total purchase price of the TI part(s) at issue in this document sold by TI to Customer on an annual basis.

12.1.2 Tape and Reel Information

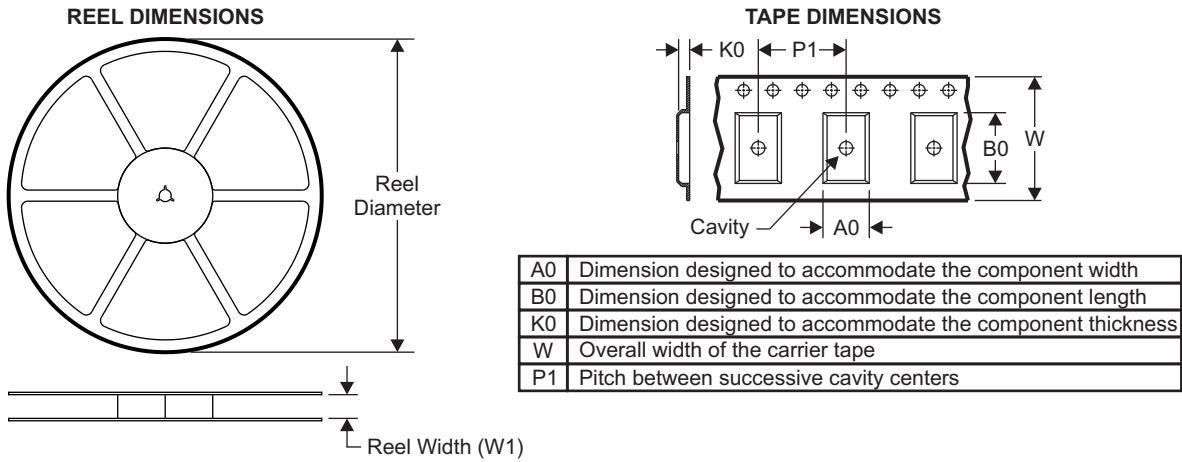

QUADRANT ASSIGNMENTS FOR PIN 1 ORIENTATION IN TAPE

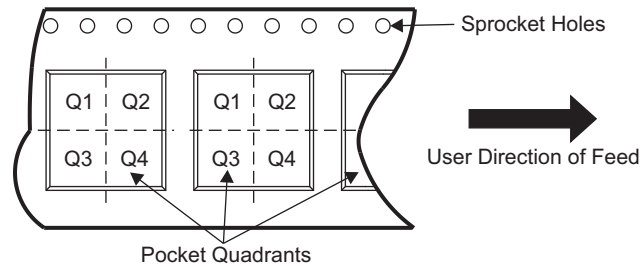

| Device | Package Type | Package Drawing | Pins | SPQ | Reel Diameter (mm) | Reel Width W1 (mm) | A0 (mm) | B0 (mm) | K0 (mm) | P1 (mm) | W (mm) | Pin1 Quadrant |
|-----------------|--------------|-----------------|------|-----|--------------------|--------------------|---------|---------|---------|---------|--------|---------------|
| DRV8702DQRHBTQ1 | VQFN | RHB | 32 | 250 | 180.0 | 12.4 | 5.25 | 5.25 | 1.1 | 8.0 | 12.0 | Q2 |

DRV8702D-Q1, DRV8703D-Q1

SLVSDX8 – MARCH 2017

www.ti.com
TAPE AND REEL BOX DIMENSIONS

| Device | Package Type | Package Drawing | Pins | SPQ | Length (mm) | Width (mm) | Height (mm) |
|-----------------|--------------|-----------------|------|-----|-------------|------------|-------------|
| DRV8702DQRHBTQ1 | VQFN | RHB | 32 | 250 | 195.0 | 200.0 | 45.0 |

PACKAGING INFORMATION

| Orderable Device | Status (1) | Package Type | Package Drawing | Pins | Package Qty | Eco Plan (2) | Lead/Ball Finish (6) | MSL Peak Temp (3) | Op Temp (°C) | Device Marking (4/5) | Samples |
|------------------|---------------|--------------|-----------------|------|-------------|-------------------------|-------------------------|----------------------|--------------|-------------------------|-------------------------|
| DRV8702DQRHBRQ1 | ACTIVE | VQFN | RHB | 32 | 3000 | Green (RoHS & no Sb/Br) | CU SN | Level-3-260C-168 HR | -40 to 125 | 8702D | Samples |
| DRV8702DQRHBTQ1 | ACTIVE | VQFN | RHB | 32 | 250 | Green (RoHS & no Sb/Br) | CU SN | Level-3-260C-168 HR | -40 to 125 | 8702D | Samples |
| DRV8703DQRHBRQ1 | ACTIVE | VQFN | RHB | 32 | 3000 | Green (RoHS & no Sb/Br) | CU SN | Level-3-260C-168 HR | -40 to 125 | 8703D | Samples |
| DRV8703DQRHBTQ1 | ACTIVE | VQFN | RHB | 32 | 250 | Green (RoHS & no Sb/Br) | CU SN | Level-3-260C-168 HR | -40 to 125 | 8703D | Samples |

(1) The marketing status values are defined as follows:

ACTIVE: Product device recommended for new designs.

LIFEBUY: TI has announced that the device will be discontinued, and a lifetime-buy period is in effect.

NRND: Not recommended for new designs. Device is in production to support existing customers, but TI does not recommend using this part in a new design.

PREVIEW: Device has been announced but is not in production. Samples may or may not be available.

OBSELETE: TI has discontinued the production of the device.

(2) Eco Plan - The planned eco-friendly classification: Pb-Free (RoHS), Pb-Free (RoHS Exempt), or Green (RoHS & no Sb/Br) - please check <http://www.ti.com/productcontent> for the latest availability information and additional product content details.

TBD: The Pb-Free/Green conversion plan has not been defined.

Pb-Free (RoHS): TI's terms "Lead-Free" or "Pb-Free" mean semiconductor products that are compatible with the current RoHS requirements for all 6 substances, including the requirement that lead not exceed 0.1% by weight in homogeneous materials. Where designed to be soldered at high temperatures, TI Pb-Free products are suitable for use in specified lead-free processes.

Pb-Free (RoHS Exempt): This component has a RoHS exemption for either 1) lead-based flip-chip solder bumps used between the die and package, or 2) lead-based die adhesive used between the die and leadframe. The component is otherwise considered Pb-Free (RoHS compatible) as defined above.

Green (RoHS & no Sb/Br): TI defines "Green" to mean Pb-Free (RoHS compatible), and free of Bromine (Br) and Antimony (Sb) based flame retardants (Br or Sb do not exceed 0.1% by weight in homogeneous material)

(3) MSL, Peak Temp. - The Moisture Sensitivity Level rating according to the JEDEC industry standard classifications, and peak solder temperature.

(4) There may be additional marking, which relates to the logo, the lot trace code information, or the environmental category on the device.

(5) Multiple Device Markings will be inside parentheses. Only one Device Marking contained in parentheses and separated by a "~" will appear on a device. If a line is indented then it is a continuation of the previous line and the two combined represent the entire Device Marking for that device.

(6) Lead/Ball Finish - Orderable Devices may have multiple material finish options. Finish options are separated by a vertical ruled line. Lead/Ball Finish values may wrap to two lines if the finish value exceeds the maximum column width.

Important Information and Disclaimer: The information provided on this page represents TI's knowledge and belief as of the date that it is provided. TI bases its knowledge and belief on information provided by third parties, and makes no representation or warranty as to the accuracy of such information. Efforts are underway to better integrate information from third parties. TI has taken and continues to take reasonable steps to provide representative and accurate information but may not have conducted destructive testing or chemical analysis on incoming materials and chemicals. TI and TI suppliers consider certain information to be proprietary, and thus CAS numbers and other limited information may not be available for release.

In no event shall TI's liability arising out of such information exceed the total purchase price of the TI part(s) at issue in this document sold by TI to Customer on an annual basis.

TAPE AND REEL INFORMATION



QUADRANT ASSIGNMENTS FOR PIN 1 ORIENTATION IN TAPE



*All dimensions are nominal

| Device | Package Type | Package Drawing | Pins | SPQ | Reel Diameter (mm) | Reel Width W1 (mm) | A0 (mm) | B0 (mm) | K0 (mm) | P1 (mm) | W (mm) | Pin1 Quadrant |
|-----------------|--------------|-----------------|------|-----|--------------------|--------------------|---------|---------|---------|---------|--------|---------------|
| DRV8702DQRHBTQ1 | VQFN | RHB | 32 | 250 | 180.0 | 12.4 | 5.25 | 5.25 | 1.1 | 8.0 | 12.0 | Q2 |
| DRV8703DQRHBTQ1 | VQFN | RHB | 32 | 250 | 180.0 | 12.4 | 5.25 | 5.25 | 1.1 | 8.0 | 12.0 | Q2 |

TAPE AND REEL BOX DIMENSIONS



*All dimensions are nominal

| Device | Package Type | Package Drawing | Pins | SPQ | Length (mm) | Width (mm) | Height (mm) |
|-----------------|--------------|-----------------|------|-----|-------------|------------|-------------|
| DRV8702DQRHBTQ1 | VQFN | RHB | 32 | 250 | 195.0 | 200.0 | 45.0 |
| DRV8703DQRHBTQ1 | VQFN | RHB | 32 | 250 | 195.0 | 200.0 | 45.0 |

RHB (S-PVQFN-N32)

PLASTIC QUAD FLATPACK NO-LEAD

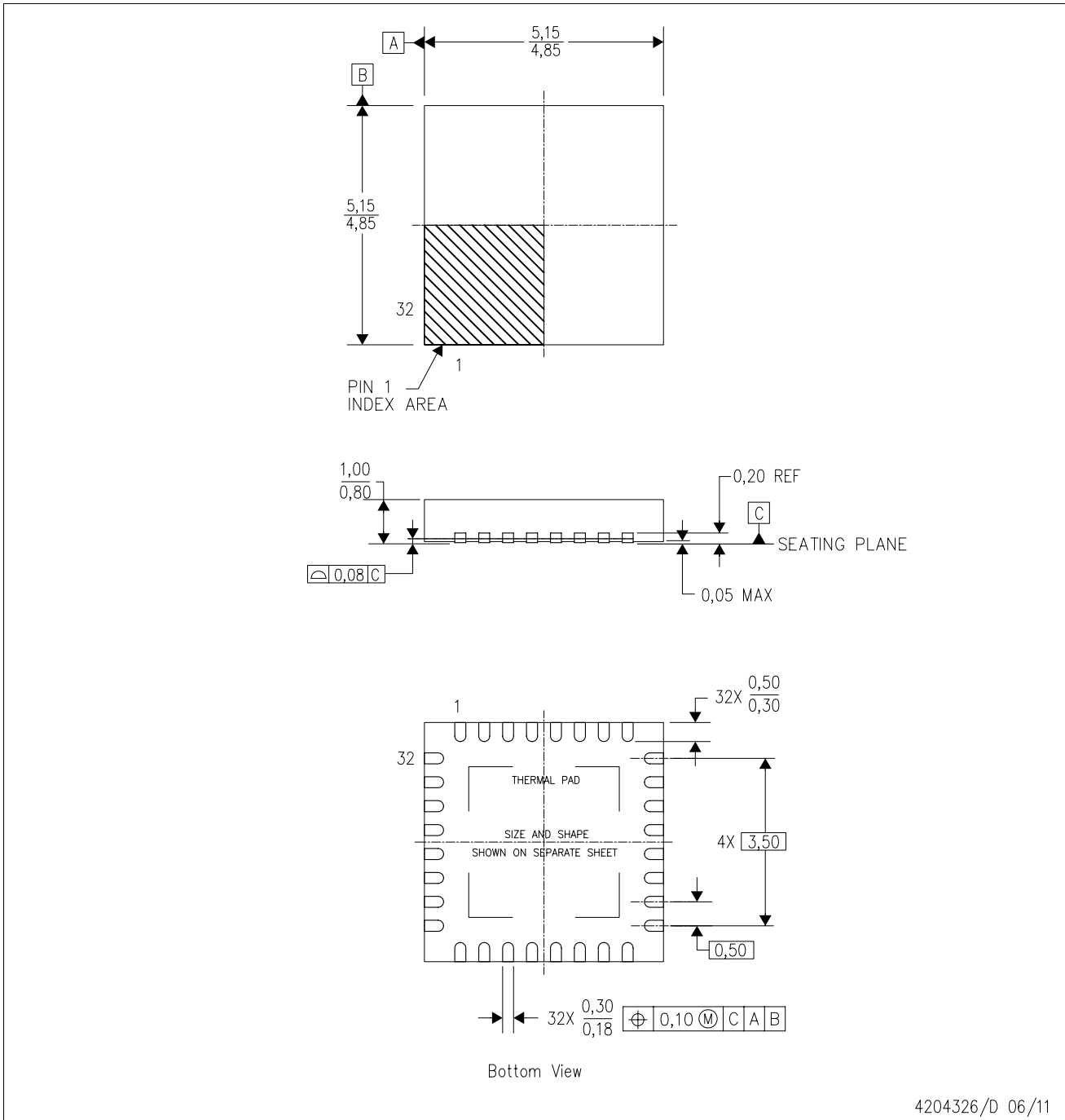

4204326/D 06/11

- NOTES:
- All linear dimensions are in millimeters. Dimensioning and tolerancing per ASME Y14.5M-1994.
 - This drawing is subject to change without notice.
 - QFN (Quad Flatpack No-Lead) Package configuration.
 - The package thermal pad must be soldered to the board for thermal and mechanical performance.
 - See the additional figure in the Product Data Sheet for details regarding the exposed thermal pad features and dimensions.
 - Falls within JEDEC MO-220.

IMPORTANT NOTICE

Texas Instruments Incorporated (TI) reserves the right to make corrections, enhancements, improvements and other changes to its semiconductor products and services per JESD46, latest issue, and to discontinue any product or service per JESD48, latest issue. Buyers should obtain the latest relevant information before placing orders and should verify that such information is current and complete.

TI's published terms of sale for semiconductor products (<http://www.ti.com/sc/docs/stdterms.htm>) apply to the sale of packaged integrated circuit products that TI has qualified and released to market. Additional terms may apply to the use or sale of other types of TI products and services.

Reproduction of significant portions of TI information in TI data sheets is permissible only if reproduction is without alteration and is accompanied by all associated warranties, conditions, limitations, and notices. TI is not responsible or liable for such reproduced documentation. Information of third parties may be subject to additional restrictions. Resale of TI products or services with statements different from or beyond the parameters stated by TI for that product or service voids all express and any implied warranties for the associated TI product or service and is an unfair and deceptive business practice. TI is not responsible or liable for any such statements.

Buyers and others who are developing systems that incorporate TI products (collectively, "Designers") understand and agree that Designers remain responsible for using their independent analysis, evaluation and judgment in designing their applications and that Designers have full and exclusive responsibility to assure the safety of Designers' applications and compliance of their applications (and of all TI products used in or for Designers' applications) with all applicable regulations, laws and other applicable requirements. Designer represents that, with respect to their applications, Designer has all the necessary expertise to create and implement safeguards that (1) anticipate dangerous consequences of failures, (2) monitor failures and their consequences, and (3) lessen the likelihood of failures that might cause harm and take appropriate actions. Designer agrees that prior to using or distributing any applications that include TI products, Designer will thoroughly test such applications and the functionality of such TI products as used in such applications.

TI's provision of technical, application or other design advice, quality characterization, reliability data or other services or information, including, but not limited to, reference designs and materials relating to evaluation modules, (collectively, "TI Resources") are intended to assist designers who are developing applications that incorporate TI products; by downloading, accessing or using TI Resources in any way, Designer (individually or, if Designer is acting on behalf of a company, Designer's company) agrees to use any particular TI Resource solely for this purpose and subject to the terms of this Notice.

TI's provision of TI Resources does not expand or otherwise alter TI's applicable published warranties or warranty disclaimers for TI products, and no additional obligations or liabilities arise from TI providing such TI Resources. TI reserves the right to make corrections, enhancements, improvements and other changes to its TI Resources. TI has not conducted any testing other than that specifically described in the published documentation for a particular TI Resource.

Designer is authorized to use, copy and modify any individual TI Resource only in connection with the development of applications that include the TI product(s) identified in such TI Resource. NO OTHER LICENSE, EXPRESS OR IMPLIED, BY ESTOPPEL OR OTHERWISE TO ANY OTHER TI INTELLECTUAL PROPERTY RIGHT, AND NO LICENSE TO ANY TECHNOLOGY OR INTELLECTUAL PROPERTY RIGHT OF TI OR ANY THIRD PARTY IS GRANTED HEREIN, including but not limited to any patent right, copyright, mask work right, or other intellectual property right relating to any combination, machine, or process in which TI products or services are used. Information regarding or referencing third-party products or services does not constitute a license to use such products or services, or a warranty or endorsement thereof. Use of TI Resources may require a license from a third party under the patents or other intellectual property of the third party, or a license from TI under the patents or other intellectual property of TI.

TI RESOURCES ARE PROVIDED "AS IS" AND WITH ALL FAULTS. TI DISCLAIMS ALL OTHER WARRANTIES OR REPRESENTATIONS, EXPRESS OR IMPLIED, REGARDING RESOURCES OR USE THEREOF, INCLUDING BUT NOT LIMITED TO ACCURACY OR COMPLETENESS, TITLE, ANY EPIDEMIC FAILURE WARRANTY AND ANY IMPLIED WARRANTIES OF MERCHANTABILITY, FITNESS FOR A PARTICULAR PURPOSE, AND NON-INFRINGEMENT OF ANY THIRD PARTY INTELLECTUAL PROPERTY RIGHTS. TI SHALL NOT BE LIABLE FOR AND SHALL NOT DEFEND OR INDEMNIFY DESIGNER AGAINST ANY CLAIM, INCLUDING BUT NOT LIMITED TO ANY INFRINGEMENT CLAIM THAT RELATES TO OR IS BASED ON ANY COMBINATION OF PRODUCTS EVEN IF DESCRIBED IN TI RESOURCES OR OTHERWISE. IN NO EVENT SHALL TI BE LIABLE FOR ANY ACTUAL, DIRECT, SPECIAL, COLLATERAL, INDIRECT, PUNITIVE, INCIDENTAL, CONSEQUENTIAL OR EXEMPLARY DAMAGES IN CONNECTION WITH OR ARISING OUT OF TI RESOURCES OR USE THEREOF, AND REGARDLESS OF WHETHER TI HAS BEEN ADVISED OF THE POSSIBILITY OF SUCH DAMAGES.

Unless TI has explicitly designated an individual product as meeting the requirements of a particular industry standard (e.g., ISO/TS 16949 and ISO 26262), TI is not responsible for any failure to meet such industry standard requirements.

Where TI specifically promotes products as facilitating functional safety or as compliant with industry functional safety standards, such products are intended to help enable customers to design and create their own applications that meet applicable functional safety standards and requirements. Using products in an application does not by itself establish any safety features in the application. Designers must ensure compliance with safety-related requirements and standards applicable to their applications. Designer may not use any TI products in life-critical medical equipment unless authorized officers of the parties have executed a special contract specifically governing such use. Life-critical medical equipment is medical equipment where failure of such equipment would cause serious bodily injury or death (e.g., life support, pacemakers, defibrillators, heart pumps, neurostimulators, and implantables). Such equipment includes, without limitation, all medical devices identified by the U.S. Food and Drug Administration as Class III devices and equivalent classifications outside the U.S.

TI may expressly designate certain products as completing a particular qualification (e.g., Q100, Military Grade, or Enhanced Product). Designers agree that it has the necessary expertise to select the product with the appropriate qualification designation for their applications and that proper product selection is at Designers' own risk. Designers are solely responsible for compliance with all legal and regulatory requirements in connection with such selection.

Designer will fully indemnify TI and its representatives against any damages, costs, losses, and/or liabilities arising out of Designer's non-compliance with the terms and provisions of this Notice.