

## Dual Full Bridge PWM Motor Driver

### FEATURES

- High-Efficiency Power Stage (up to 96%) with Low  $R_{DS(on)}$  MOSFETs (80 m $\Omega$  at  $T_J = 25^\circ\text{C}$ )
- Operating Supply Voltage up to 50 V (65 V Absolute Maximum)
- 10 A Continuous Output Current and 24 A Peak Current per Device
- PWM Operating Frequency up to 500 kHz
- Integrated Self-Protection Circuits
- Programmable Cycle-by-Cycle Current Limit Protection
- Independent Supply and Ground Pins for Each Half Bridge
- Intelligent Gate Drive and Cross Conduction Prevention
- No External Snubber or Schottky Diode is Required
- Thermally Enhanced DKD (36-pin PSOP3) Package

### APPLICATIONS

- DC and Brushless DC Motors
- Three Phase Permanent Magnet Synchronous Motors
- Robotic and Haptic Control System
- Actuators and Pumps
- Precision Instruments
- TEC Drivers

### DESCRIPTION

The DRV8402 is a high performance, integrated dual full bridge motor driver with an advanced protection system. Because of the low  $R_{DS(on)}$  and intelligent gate drive design, the efficiency of this motor driver can be up to 96%, which enables the use of smaller power supplies and heatsinks, and is a good candidate for energy efficient applications. This device requires two power supplies, one at 12 V for GVDD and VDD, and one up to 50 V for PVDD. The DRV8402 is capable of driving 5 A continuous RMS current and 12 A peak current per full bridge with low idle power dissipation. It can also be used for up to 10 A continuous current and 24 A peak current in parallel full bridge operation.

The DRV8402 can operate at up to 500 kHz switching frequency while still maintains precise control and high efficiency. It also has an innovative protection system integrated on-chip, safeguarding the device against a wide range of fault conditions that could damage the system. These safeguards are short-circuit protection, overcurrent protection, undervoltage protection, and two-stage thermal protection. The DRV8402 has a current-limiting circuit that prevents device shutdown during load transients such as motor start-up. A programmable overcurrent detector allows adjustable current limit and protection level to meet different motor requirements.

The DRV8402 has unique independent supply and ground pins for each half bridge, which makes it possible to provide current measurement through external shunt resistor and support multiple motors with different power supply voltage requirements.

### Simplified Application Diagram

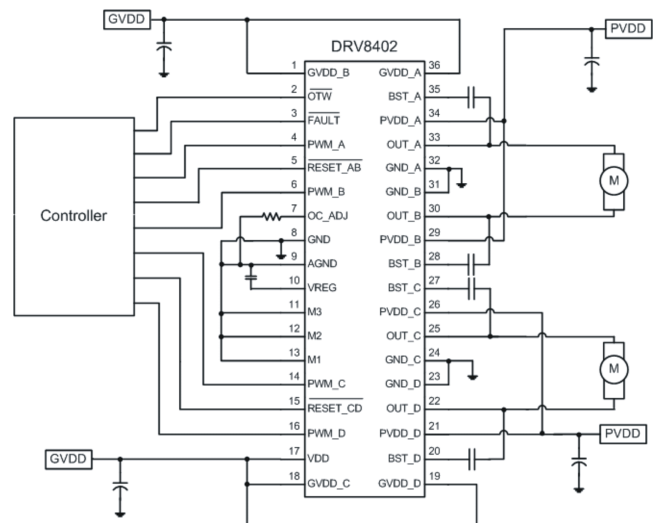

Please be aware that an important notice concerning availability, standard warranty, and use in critical applications of Texas Instruments semiconductor products and disclaimers thereto appears at the end of this data sheet.



These devices have limited built-in ESD protection. The leads should be shorted together or the device placed in conductive foam during storage or handling to prevent electrostatic damage to the MOS gates.

## ABSOLUTE MAXIMUM RATINGS

Over operating free-air temperature range unless otherwise noted <sup>(1)</sup>

PARAMETER	VALUE
VDD to AGND	–0.3 V to 13.2 V
GVDD_X to AGND	–0.3 V to 13.2 V
PVDD_X to GND_X <sup>(2)</sup>	–0.3 V to 65 V
OUT_X to GND_X <sup>(2)</sup>	–0.3 V to 65V
BST_X to GND_X <sup>(2)</sup>	–0.3 V to 75 V
Transient peak output current (per pin), pulse width limited by internal over-current protection circuit.	15 A
VREG to AGND	–0.3 V to 4.2 V
GND_X to GND	–0.3 V to 0.3 V
GND_X to AGND	–0.3 V to 0.3 V
GND to AGND	–0.3 V to 0.3 V
PWM_X, OC_ADJ, M1, M2, M3 to AGND	–0.3 V to 4.2 V
RESET_X, FAULT, OTW to AGND	–0.3 V to 7 V
Maximum continuous sink current (FAULT, OTW)	9 mA
Maximum operating junction temperature range, T <sub>J</sub>	–40°C to 150°C
Storage temperature, T <sub>stg</sub>	–55°C to 150°C

- (1) Stresses beyond those listed under *Absolute Maximum Ratings* may cause permanent damage to the device. These are stress ratings only, and functional operation of the device at these or any other conditions beyond those indicated under *Recommended Operating Conditions* is not implied. Exposure to absolute-maximum-rated conditions for extended periods may affect device reliability.
- (2) These voltages represent the dc voltage + peak ac waveform measured at the terminal of the device in all conditions.

## RECOMMENDED OPERATING CONDITIONS

PARAMETER	DESCRIPTION	MIN	NOM	MAX	UNIT
PVDD_X	Half bridge X (A, B, C, or D) DC supply voltage	0	50	52.5	V
GVDD_X	Supply for logic regulators and gate-drive circuitry	11.4	12.3	13.2	V
VDD	Digital regulator input	11.4	12.3	13.2	V
I <sub>O_pulse</sub>	Pulsed peak current per output pin			12	A
I <sub>O</sub>	Continuous current per output pin			5	A
F <sub>Sw</sub>	PWM switching frequency			500	kHz
L <sub>O</sub>	Minimum output inductance under short-circuit condition and parallel mode		4		μH
R <sub>OC_P_CBC</sub>	OC programming resistor range in cycle by cycle current limit modes, Resistor tolerance = 5%	27		39	kΩ
R <sub>OC_P_OCL</sub>	OC programming resistor range in OC latching shutdown modes, Resistor tolerance = 5%	22		39	kΩ
T <sub>A</sub>	Operating ambient temperature	–40		85	°C

## Package Heat Dissipation Ratings

PARAMETER	VALUE
R <sub>θJC</sub> , junction-to-case (heat slug) thermal resistance (all bridges running)	1°C/W
R <sub>θJA</sub> , junction-to-ambient thermal resistance	This device is not intended to be used without a heatsink. Therefore, R <sub>θJA</sub> is not specified. See the <i>Thermal Information</i> section.
Exposed heat slug area	80 mm <sup>2</sup>

## DEVICE INFORMATION

### Pin Assignment

The DRV8402 is available in a thermally enhanced package:

- 36-pin PSOP3 package (DKD)

This package contains a heat slug that is located on the top side of the device for convenient thermal coupling to the heatsink.

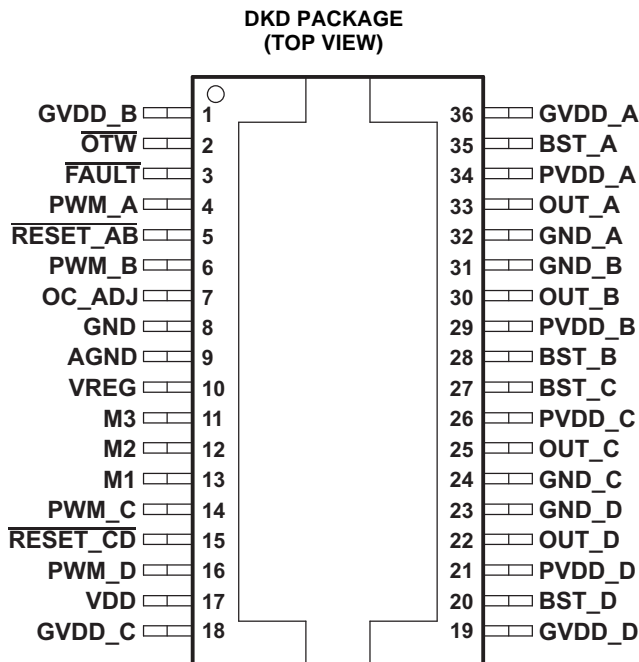

### MODE Selection Pins

MODE PINS			OUTPUT CONFIGURATION	DESCRIPTION
M3	M2	M1		
0	0	0	2 FB	Dual full bridge with cycle-by-cycle current limit
0	0	1	2 FB	Dual full bridge with OC latching shutdown (no cycle-by-cycle current limit)
0	1	0	1 PFB	Parallel full bridge with cycle-by-cycle current limit
0	1	1	1 PFB	Parallel full bridge with OC latching shutdown
1	0	0	4 HB	Half bridge with cycle-by-cycle current limit. Protection works similarly to full bridge mode. Only difference in half bridge mode is that OUT_X is Hi-Z instead of a pulldown through internal pulldown resistor when RESET pin is low.
1	0	1	4 HB	Half bridge with OC latching shutdown. Protection works similarly to full bridge mode. Only difference in half bridge mode is that OUT_X is Hi-Z instead of a pulldown through internal pulldown resistor when RESET pin is low.
1	1	0	Reserved	
1	1	1		

## Pin Functions

PIN		FUNCTION <sup>(1)</sup>	DESCRIPTION
NAME	DKD NO.		
AGND	9	P	Analog ground
BST_A	35	P	High side bootstrap supply (BST), external capacitor to OUT_A required
BST_B	28	P	High side bootstrap supply (BST), external capacitor to OUT_B required
BST_C	27	P	High side bootstrap supply (BST), external capacitor to OUT_C required
BST_D	20	P	High side bootstrap supply (BST), external capacitor to OUT_D required
GND	8	P	Ground
GND_A	32	P	Power ground for half-bridge A
GND_B	31	P	Power ground for half-bridge B
GND_C	24	P	Power ground for half-bridge C
GND_D	23	P	Power ground for half-bridge D
GVDD_A	36	P	Gate-drive voltage supply requires 0.1- $\mu$ F capacitor to AGND
GVDD_B	1	P	Gate-drive voltage supply requires 0.1- $\mu$ F capacitor to AGND
GVDD_C	18	P	Gate-drive voltage supply requires 0.1- $\mu$ F capacitor to AGND
GVDD_D	19	P	Gate-drive voltage supply requires 0.1- $\mu$ F capacitor to AGND
M1	13	I	Mode selection pin
M2	12	I	Mode selection pin
M3	11	I	Mode selection pin
OC_ADJ	7	O	Analog overcurrent programming pin requires resistor to ground
$\overline{\text{OTW}}$	2	O	Overtemperature warning signal, open-drain, active-low
OUT_A	33	O	Output, half-bridge A
OUT_B	30	O	Output, half-bridge B
OUT_C	25	O	Output, half-bridge C
OUT_D	22	O	Output, half-bridge D
PVDD_A	34	P	Power supply input for half-bridge A requires close decoupling of 0.01- $\mu$ F capacitor in parallel with a 1.0- $\mu$ F capacitor to GND_A.
PVDD_B	29	P	Power supply input for half-bridge B requires close decoupling of 0.01- $\mu$ F capacitor in parallel with a 1.0- $\mu$ F capacitor to GND_B.
PVDD_C	26	P	Power supply input for half-bridge C requires close decoupling of 0.01- $\mu$ F capacitor in parallel with a 1.0- $\mu$ F capacitor to GND_C.
PVDD_D	21	P	Power supply input for half-bridge D requires close decoupling of 0.01- $\mu$ F capacitor in parallel with a 1.0- $\mu$ F capacitor to GND_D.
PWM_A	4	I	Input signal for half-bridge A
PWM_B	6	I	Input signal for half-bridge B
PWM_C	14	I	Input signal for half-bridge C
PWM_D	16	I	Input signal for half-bridge D
$\overline{\text{RESET\_AB}}$	5	I	Reset signal for half-bridge A and half-bridge B, active-low
$\overline{\text{RESET\_CD}}$	15	I	Reset signal for half-bridge C and half-bridge D, active-low
$\overline{\text{FAULT}}$	3	O	Fault signal, open-drain, active-low
VDD	17	P	Power supply for digital voltage regulator requires a 47- $\mu$ F capacitor in parallel with a 0.1- $\mu$ F capacitor to GND for decoupling.
VREG	10	P	Digital regulator supply filter pin requires 0.1- $\mu$ F capacitor to AGND.

(1) I = input, O = output, P = power

SYSTEM BLOCK DIAGRAM

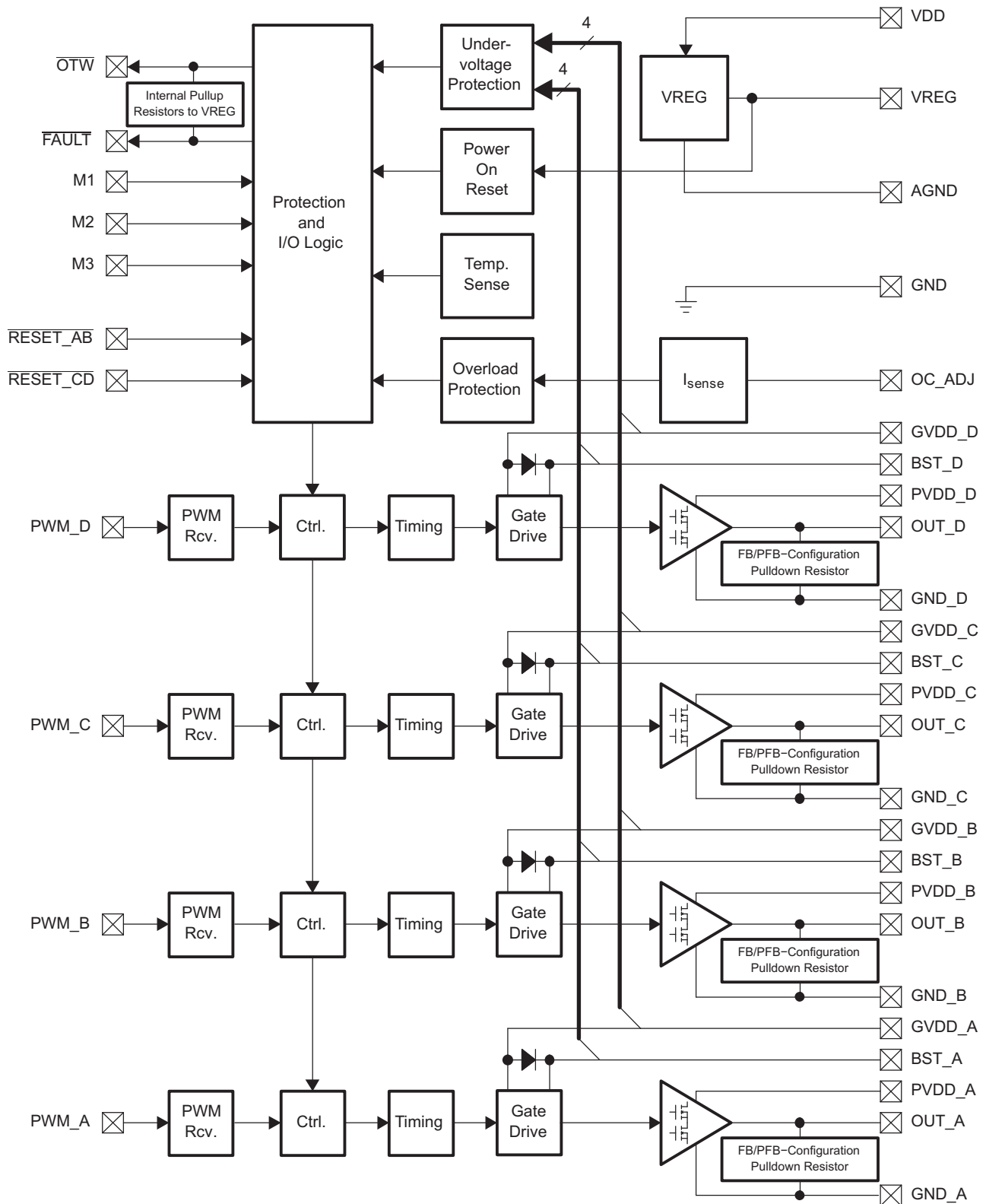

### ELECTRICAL CHARACTERISTICS

Ta = 25 °C, PVDD = 50 V, GVDD = VDD = 12 V, F<sub>sw</sub> = 400 kHz, unless otherwise noted. All performance is in accordance with recommended operating conditions unless otherwise specified.

PARAMETER		TEST CONDITIONS	MIN	TYP	MAX	UNIT
<b>Internal Voltage Regulator and Current Consumption</b>						
V <sub>REG</sub>	Voltage regulator, only used as a reference node	VDD = 12 V	2.95	3.3	3.65	V
I <sub>VDD</sub>	VDD supply current	Idle, reset mode		9	12	mA
I <sub>GVDD_X</sub>	Gate supply current per half-bridge	Reset mode		1.7	2	mA
I <sub>PVDD_X</sub>	Half-bridge X (A, B, C, or D) idle current	Reset mode		0.5	1	mA
<b>Output Stage</b>						
R <sub>DS(on)</sub>	MOSFET drain-to-source resistance, low side (LS)	T <sub>J</sub> = 25°C, includes metallization resistance, GVDD = 12 V		90		mΩ
	MOSFET drain-to-source resistance, high side (HS)	T <sub>J</sub> = 25°C, includes metallization resistance, GVDD = 12 V		90		mΩ
V <sub>F</sub>	Diode forward voltage drop	T <sub>J</sub> = 25°C - 125°C, I <sub>O</sub> = 5 A		1		V
t <sub>R</sub>	Output rise time	Resistive load, I <sub>O</sub> = 5 A		9		nS
t <sub>F</sub>	Output fall time	Resistive load, I <sub>O</sub> = 5 A		9		nS
t <sub>PD_ON</sub>	Propagation delay when FET is on	Resistive load, I <sub>O</sub> = 5 A		42		nS
t <sub>PD_OFF</sub>	Propagation delay when FET is off	Resistive load, I <sub>O</sub> = 5 A		40		nS
t <sub>DT</sub>	Dead time between HS and LS FETs	Resistive load, I <sub>O</sub> = 5 A		5		nS
<b>I/O Protection</b>						
V <sub>uvp,G</sub>	Gate supply voltage GVDD_X undervoltage protection			8.5		V
V <sub>uvp,hyst</sub> <sup>(1)</sup>	Hysteresis for gate supply undervoltage event			0.8		V
OTW <sup>(1)</sup>	Overtemperature warning		115	125	135	°C
OTW <sub>hyst</sub> <sup>(1)</sup>	Hysteresis temperature to reset $\overline{\text{OTW}}$ event			25		°C
OTSD <sup>(1)</sup>	Overtemperature shut down			150		°C
OTE-OTW <sub>differential</sub> <sup>(1)</sup>	OTE-OTW overtemperature detect temperature difference			25		°C
OTSD <sub>HYST</sub> <sup>(1)</sup>	Hysteresis temperature for $\overline{\text{FAULT}}$ to be released following an OTSD event.			25		°C
I <sub>OC</sub>	Overcurrent limit protection	Resistor—programmable, nominal, R <sub>OCP</sub> = 27 kΩ		10.6		A
I <sub>OCT</sub>	Overcurrent response time	Time from application of short condition to Hi-Z of affected FET(s)		250		ns
R <sub>PD</sub>	Internal pulldown resistor at the output of each half-bridge	Connected when RESET_AB or RESET_CD is active to provide bootstrap capacitor charge. Not used in SE mode		1		kΩ
<b>Static Digital Specifications</b>						
V <sub>IH</sub>	High-level input voltage	PWM_A, PWM_B, PWM_C, PWM_D, M1, M2, M3, RESET_AB, RESET_CD		2		V
V <sub>IL</sub>	Low-level input voltage				0.8	V
I <sub>ikg</sub>	Input leakage current		-100		100	μA
<b>OTW / FAULT</b>						
R <sub>INT_PU</sub>	Internal pullup resistance, $\overline{\text{OTW}}$ to VREG, $\overline{\text{FAULT}}$ to VREG		20	26	35	kΩ
V <sub>OH</sub>	High-level output voltage	Internal pullup resistor only	2.95	3.3	3.65	V
		External pullup of 4.7 kΩ to 5 V	4.5		5	
V <sub>OL</sub>	Low-level output voltage	I <sub>O</sub> = 4 mA		0.2	0.4	V

(1) Specified by design

TYPICAL CHARACTERISTICS

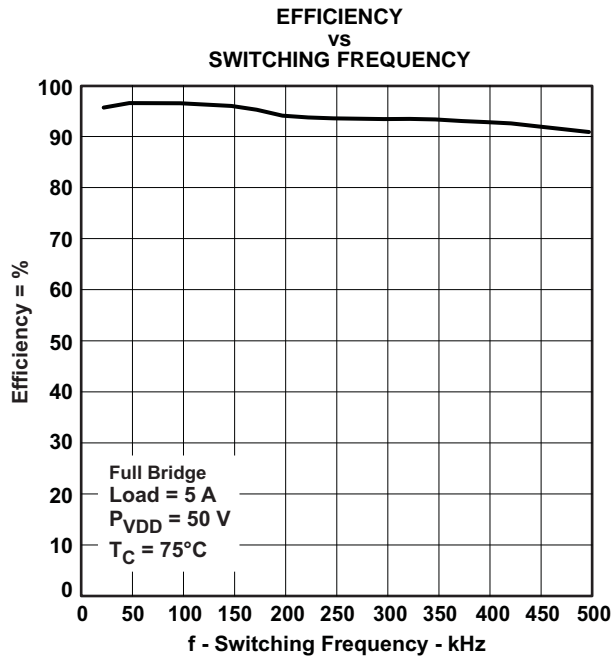

Figure 1.

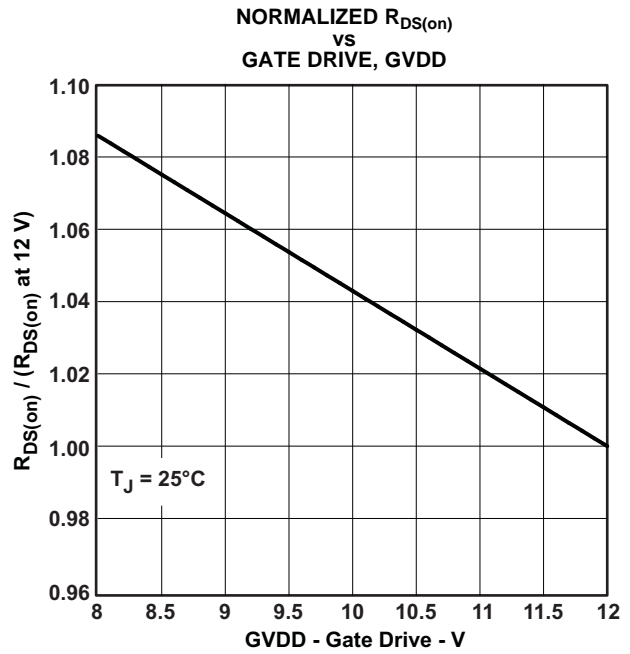

Figure 2.

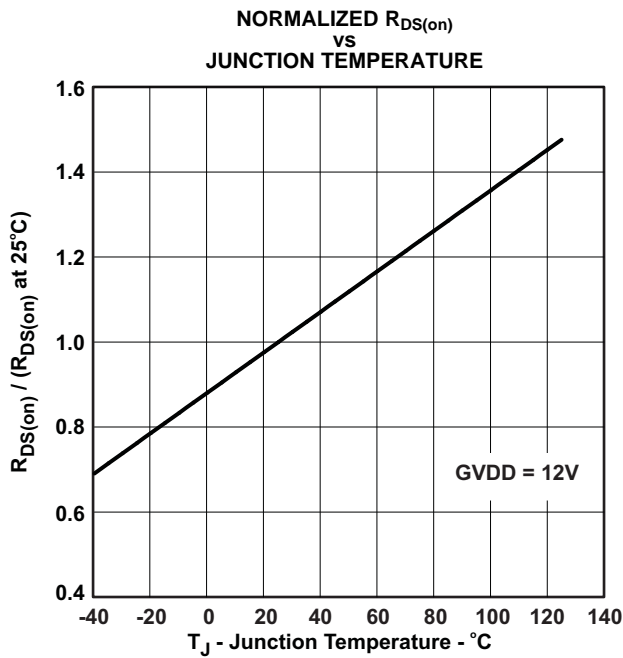

Figure 3.

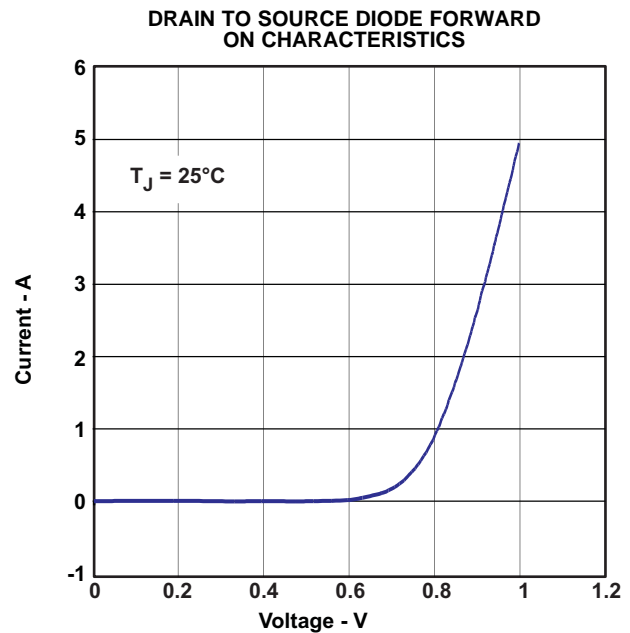

Figure 4.

TYPICAL CHARACTERISTICS (continued)

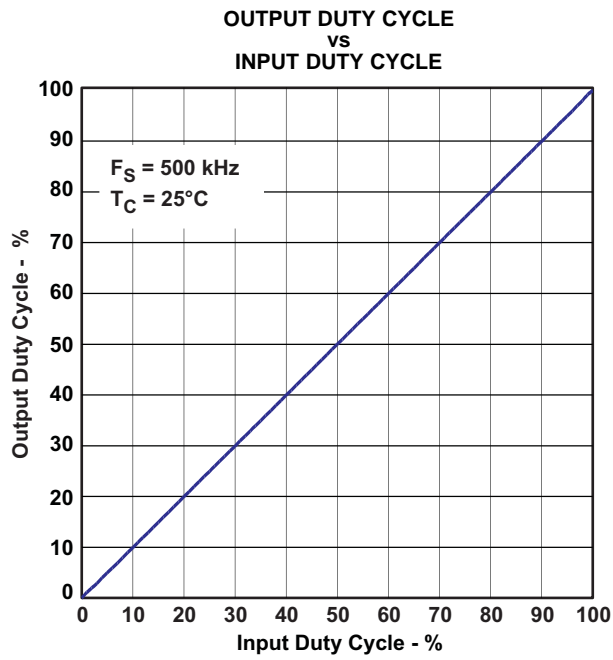

Figure 5.



## THEORY OF OPERATION

### POWER SUPPLIES

To help with system design, the DRV8402 needs only a 12 V supply in addition to power-stage supply. An internal voltage regulator provides suitable voltage levels for the digital and low-voltage analog circuitry. Additionally, all circuitry requiring a floating voltage supply, for example, the high-side gate drive, is accommodated by built-in bootstrap circuitry requiring only a few external capacitors.

To provide electrical characteristics, the PWM signal path including gate drive and output stage is designed as identical, independent half-bridges. For this reason, each half-bridge has separate gate drive supply (GVDD\_X), bootstrap pins (BST\_X), and power-stage supply pins (PVDD\_X). Furthermore, an additional pin (VDD) is provided as supply for all common circuits. Although supplied from the same 12-V source, it is recommended that a 1 – 10  $\Omega$  resistor is used to separate the GVDD\_X pins from VDD on the printed-circuit board (PCB). Special attention should be paid to placing all decoupling capacitors as close to their associated pins as possible. In general, inductance between the power supply pins and decoupling capacitors must be avoided.

For a properly functioning bootstrap circuit, a small ceramic capacitor must be connected from each bootstrap pin (BST\_X) to the power-stage output pin (OUT\_X). When the power-stage output is low, the bootstrap capacitor is charged through an internal diode connected between the gate-drive power-supply pin (GVDD\_X) and the bootstrap pin. When the power-stage output is high, the bootstrap capacitor potential is shifted above the output potential and thus provides a suitable voltage supply for the high-side gate driver. In an application with PWM switching frequencies in the range from 25 kHz to 500 kHz, the use of 47 nF ceramic capacitors, size 0603 or 0805, is recommended for the bootstrap supply. These 47 nF capacitors ensure sufficient energy storage, even during minimal PWM duty cycles, to keep the high-side power stage FET fully turned on during the remaining part of the PWM cycle. In an application running at a switching frequency lower than 25 kHz, the bootstrap capacitor might need to be increased in value.

Special attention should be paid to the power-stage power supply; this includes component selection, PCB placement, and routing. As indicated, each half-bridge has independent power-stage supply pins (PVDD\_X). For optimal electrical performance, EMI

compliance, and system reliability, it is important that each PVDD\_X pin is decoupled with a ceramic capacitor placed as close as possible to each supply pin. It is recommended to follow the PCB layout of the DRV8402 in EVM board.

The 12 V supply should be from a low-noise, low-output-impedance voltage regulator. Likewise, the 50 V power-stage supply is assumed to have low output impedance and low noise. The power-supply sequence is not critical as facilitated by the internal power-on-reset circuit. Moreover, the DRV8402 is fully protected against erroneous power-stage turn-on due to parasitic gate charging. Thus, voltage-supply ramp rates (dv/dt) are non-critical within the specified range (see the *Recommended Operating Conditions* section of this data sheet).

### SYSTEM POWER-UP/POWER-DOWN SEQUENCE

#### Powering Up

The DRV8402 does not require a power-up sequence. The outputs of the H-bridges remain in a high impedance state until the gate-drive supply voltage (GVDD\_X) and VDD voltage are above the undervoltage protection (UVP) voltage threshold (see the *Electrical Characteristics* section of this data sheet). Although not specifically required, holding RESET\_AB and RESET\_CD in a low state while powering up the device is recommended. This allows an internal circuit to charge the external bootstrap capacitors by enabling a weak pulldown of the half-bridge output (except in half-bridge modes).

#### Powering Down

The DRV8402 does not require a power-down sequence. The device remains fully operational as long as the gate-drive supply (GVDD\_X) voltage and VDD voltage are above the UVP voltage threshold (see the *Electrical Characteristics* section of this data sheet). Although not specifically required, it is a good practice to hold RESET\_AB and RESET\_CD low during power down to prevent any unknown state during this transition.

## ERROR REPORTING

The  $\overline{\text{FAULT}}$  and  $\overline{\text{OTW}}$  pins are both active-low, open-drain outputs. Their function is for protection-mode signaling to a PWM controller or other system-control device.

Any fault resulting in device shutdown is signaled by the  $\overline{\text{FAULT}}$  pin going low. Likewise,  $\overline{\text{OTW}}$  goes low when the device junction temperature exceeds 125°C (see [Table 1](#)).

**Table 1.**

$\overline{\text{FAULT}}$	$\overline{\text{OTW}}$	DESCRIPTION
0	0	Overtemperature warning and (overtemperature shut down or overcurrent shut down or undervoltage protection) occurred
0	1	Overcurrent shut-down or undervoltage protection occurred
1	0	Overtemperature warning
1	1	Device under normal operation

Note that asserting either  $\overline{\text{RESET\_AB}}$  or  $\overline{\text{RESET\_CD}}$  low forces the  $\overline{\text{FAULT}}$  signal high, independent of faults being present. For proper error reporting, set both  $\overline{\text{RESET\_AB}}$  and  $\overline{\text{RESET\_CD}}$  high during normal operation.

TI recommends monitoring the  $\overline{\text{OTW}}$  signal using the system microcontroller and responding to an  $\overline{\text{OTW}}$  signal by reducing the load current to prevent further heating of the device resulting in device overtemperature shutdown (OTSD).

To reduce external component count, an internal pullup resistor to 3.3 V is provided on both  $\overline{\text{FAULT}}$  and  $\overline{\text{OTW}}$  outputs. Level compliance for 5-V logic can be obtained by adding external pull-up resistors to 5 V (see the *Electrical Characteristics* section of this data sheet for further specifications).

## DEVICE PROTECTION SYSTEM

The DRV8402 contains advanced protection circuitry carefully designed to facilitate system integration and ease of use, as well as to safeguard the device from permanent failure due to a wide range of fault conditions such as short circuits, overcurrent, overtemperature, and undervoltage. The DRV8402 responds to a fault by immediately setting the power stage in a high-impedance (Hi-Z) state and asserting the  $\overline{\text{FAULT}}$  pin low. In situations other than overcurrent or overtemperature, the device automatically recovers when the fault condition has been removed or the gate supply voltage has increased. For highest possible reliability, recovering from an overcurrent shut down (OCSD) or OTSD fault requires external reset of the device (see the *Device Reset* section of this data sheet) no sooner than 1 second after the shutdown.

## Bootstrap Capacitor Under Voltage Protection

When the device runs at a low switching frequency (e.g. less than 20 kHz with 47 nF bootstrap capacitor), the bootstrap capacitor voltage might not be able to maintain a proper voltage level for the high-side gate driver. A bootstrap capacitor undervoltage protection circuit (BST\_UVP) will start under this circumstance to prevent the potential failure of the high-side MOSFET. When the voltage on the bootstrap capacitors is less than required for safe operation, the DRV8402 will initiate bootstrap capacitor recharge sequences (turn off high side FET for a short period) until the bootstrap capacitors are properly charged for safe operation. This function may also be activated when PWM duty cycle is too high (e.g. higher than 99.5%). Note that bootstrap capacitor might not be able to be charged up if no load is presented at output.

Because the extra pulse width to charge bootstrap capacitor is so short, that the output current disruption due to the extra charge is negligible most of the time when output inductor is present.

## Overcurrent (OC) Protection

The device has independent, fast-reacting current detectors with programmable trip threshold (OC threshold) on all high-side and low-side power-stage FETs. There are two settings for OC protection through Mode selection pins: cycle-by-cycle (CBC) current limiting mode and OC latching (OCL) shut down mode.

In CBC current limiting mode, the detector outputs are monitored by two protection systems. The first protection system controls the power stage in order to prevent the output current from further increasing, i.e., it performs a CBC current-limiting function rather than prematurely shutting down the device. This feature could effectively limit the inrush current during motor start-up or transient without damaging the device. During short to power and short to ground condition, the current limit circuitry might not be able to control the current in a proper level, a second protection system triggers a latching shutdown, resulting in the power stage being set in the high-impedance (Hi-Z) state. Current limiting and overcurrent protection are independent for half-bridges A, B, C, and, D, respectively.

In OCL shut down mode, the cycle-by-cycle current limit and error recovery circuitry is disabled and an overcurrent condition will cause the device to shutdown immediately. After shutdown,  $\overline{\text{RESET\_AB}}$  and/or  $\overline{\text{RESET\_CD}}$  must be asserted to restore normal operation after the overcurrent condition is removed.

For added flexibility, the OC threshold is programmable within a limited range using a single external resistor connected between the OC\_ADJ pin and AGND pin. See [Table 2](#) for information on the correlation between programming-resistor value and the OC threshold. It should be noted that a properly functioning overcurrent detector assumes the presence of a proper inductor at the power-stage output (minimum 2  $\mu$ H). Short-circuit protection is not provided directly at the output pins of the power stage, but only after the inductor. If a further smaller inductor is preferred for any reason, using OCL mode setting is recommended.

**Table 2.**

OC-Adjust Resistor Values (k $\Omega$ )	Max. Current Before OC Occurs (A)
22 <sup>(1)</sup>	12.2
24 <sup>(1)</sup>	11.5
27	10.6
30	9.9
33	9.3
36	8.7
39	8.2

(1) Recommended to use in OCL Mode Only

### Overtemperature Protection

The DRV8402 has a two-level temperature-protection system that asserts an active-low warning signal (OTW) when the device junction temperature exceeds 125°C (nominal) and, if the device junction temperature exceeds 150°C (nominal), the device is put into thermal shutdown, resulting in all half-bridge outputs being set in the high-impedance (Hi-Z) state and  $\overline{\text{FAULT}}$  being asserted low. OTSD is latched in this case and RESET\_AB and RESET\_CD must be asserted low.

### Undervoltage Protection (UVP) and Power-On Reset (POR)

The UVP and POR circuits of the DRV8402 fully protect the device in any power-up/down and brownout situation. While powering up, the POR circuit resets the overcurrent circuit and ensures that all circuits are fully operational when the GVDD\_X and VDD supply voltages reach 9.8 V (typical). Although GVDD\_X and VDD are independently monitored, a supply voltage drop below the UVP threshold on any VDD or GVDD\_X pin results in all half-bridge outputs immediately being set in the high-impedance (Hi-Z) state and  $\overline{\text{FAULT}}$  being asserted low. The device automatically resumes operation when all supply voltage on the bootstrap capacitors have increased above the UVP threshold.

### DEVICE RESET

Two reset pins are provided for independent control of half-bridges A/B and C/D. When  $\overline{\text{RESET\_AB}}$  is asserted low, all four power-stage FETs in half-bridges A and B are forced into a high-impedance (Hi-Z) state. Likewise, asserting  $\overline{\text{RESET\_CD}}$  low forces all four power-stage FETs in half-bridges C and D into a high-impedance state.

In full bridge and parallel full bridge configurations, to accommodate bootstrap charging prior to switching start, asserting the reset inputs low enables weak pulldown of the half-bridge outputs. In half bridge configuration, the weak pulldowns are not enabled, and it is, therefore, recommended to precharge bootstrap capacitor by providing a low pulse on the PWM inputs first when reset is asserted high.

Asserting either reset input low removes any fault information to be signaled on the  $\overline{\text{FAULT}}$  output, i.e.,  $\overline{\text{FAULT}}$  is forced high.

A rising-edge transition on either reset input allows the device to resume operation after an overcurrent fault.



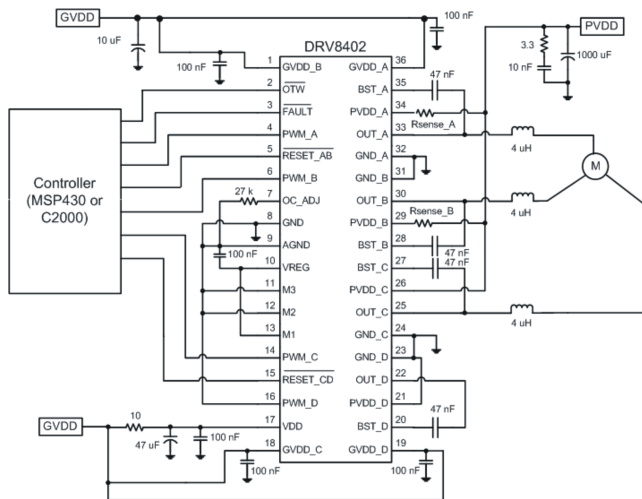

**Figure 8. Application Diagram Example for Three Phase PMSM Operation**

## THERMAL INFORMATION

The thermally enhanced package provided with the DRV8402 is designed to interface directly to heat sink using a thermal interface compound, (e.g., Arctic Silver, TIMTronics 413, Ceramic thermal compound, etc.). The heat sink then absorbs heat from the ICs and couples it to the local air.

$R_{\theta JA}$  is a system thermal resistance from junction to ambient air. As such, it is a system parameter with the following components:

- $R_{\theta JC}$  (the thermal resistance from junction to case, or in this example the heat slug)
- Thermal grease thermal resistance
- Heat sink thermal resistance

The thermal grease thermal resistance can be calculated from the exposed heat slug area and the thermal grease manufacturer's area thermal resistance (expressed in  $^{\circ}\text{C}\text{-in}^2/\text{W}$  or  $^{\circ}\text{C}\text{-mm}^2/\text{W}$ ). The approximate exposed heat slug size is as follows:

- DRV8402, 36-pin PSOP3 .....  $0.124 \text{ in}^2$  ( $80 \text{ mm}^2$ )

The thermal resistance of thermal pads is considered higher than a thin thermal grease layer. Thermal tape has an even higher thermal resistance and should not be used at all. Heat sink thermal resistance is predicted by the heat sink vendor, modeled using a continuous flow dynamics (CFD) model, or measured.

Thus the system  $R_{\theta JA} = R_{\theta JC} + \text{thermal grease resistance} + \text{heat sink resistance}$ .

See the TI application report, *IC Package Thermal Metrics* (SPRA953A), for more thermal information.

**PACKAGING INFORMATION**

Orderable Device	Status <sup>(1)</sup>	Package Type	Package Drawing	Pins	Package Qty	Eco Plan <sup>(2)</sup>	Lead/Ball Finish	MSL Peak Temp <sup>(3)</sup>
DRV8402DKD	ACTIVE	SSOP	DKD	36	29	Green (RoHS & no Sb/Br)	CU NIPDAU	Level-4-260C-72 HR
DRV8402DKDR	ACTIVE	SSOP	DKD	36	500	Green (RoHS & no Sb/Br)	CU NIPDAU	Level-4-260C-72 HR

<sup>(1)</sup> The marketing status values are defined as follows:

**ACTIVE:** Product device recommended for new designs.

**LIFEBUY:** TI has announced that the device will be discontinued, and a lifetime-buy period is in effect.

**NRND:** Not recommended for new designs. Device is in production to support existing customers, but TI does not recommend using this part in a new design.

**PREVIEW:** Device has been announced but is not in production. Samples may or may not be available.

**OBsolete:** TI has discontinued the production of the device.

<sup>(2)</sup> Eco Plan - The planned eco-friendly classification: Pb-Free (RoHS), Pb-Free (RoHS Exempt), or Green (RoHS & no Sb/Br) - please check <http://www.ti.com/productcontent> for the latest availability information and additional product content details.

**TBD:** The Pb-Free/Green conversion plan has not been defined.

**Pb-Free (RoHS):** TI's terms "Lead-Free" or "Pb-Free" mean semiconductor products that are compatible with the current RoHS requirements for all 6 substances, including the requirement that lead not exceed 0.1% by weight in homogeneous materials. Where designed to be soldered at high temperatures, TI Pb-Free products are suitable for use in specified lead-free processes.

**Pb-Free (RoHS Exempt):** This component has a RoHS exemption for either 1) lead-based flip-chip solder bumps used between the die and package, or 2) lead-based die adhesive used between the die and leadframe. The component is otherwise considered Pb-Free (RoHS compatible) as defined above.

**Green (RoHS & no Sb/Br):** TI defines "Green" to mean Pb-Free (RoHS compatible), and free of Bromine (Br) and Antimony (Sb) based flame retardants (Br or Sb do not exceed 0.1% by weight in homogeneous material)

<sup>(3)</sup> MSL, Peak Temp. -- The Moisture Sensitivity Level rating according to the JEDEC industry standard classifications, and peak solder temperature.

**Important Information and Disclaimer:**The information provided on this page represents TI's knowledge and belief as of the date that it is provided. TI bases its knowledge and belief on information provided by third parties, and makes no representation or warranty as to the accuracy of such information. Efforts are underway to better integrate information from third parties. TI has taken and continues to take reasonable steps to provide representative and accurate information but may not have conducted destructive testing or chemical analysis on incoming materials and chemicals. TI and TI suppliers consider certain information to be proprietary, and thus CAS numbers and other limited information may not be available for release.

In no event shall TI's liability arising out of such information exceed the total purchase price of the TI part(s) at issue in this document sold by TI to Customer on an annual basis.

**TAPE AND REEL INFORMATION**



**QUADRANT ASSIGNMENTS FOR PIN 1 ORIENTATION IN TAPE**



\*All dimensions are nominal

Device	Package Type	Package Drawing	Pins	SPQ	Reel Diameter (mm)	Reel Width W1 (mm)	A0 (mm)	B0 (mm)	K0 (mm)	P1 (mm)	W (mm)	Pin1 Quadrant
DRV8402DKDR	SSOP	DKD	36	500	330.0	24.4	14.7	16.4	4.0	20.0	24.0	Q1

**TAPE AND REEL BOX DIMENSIONS**

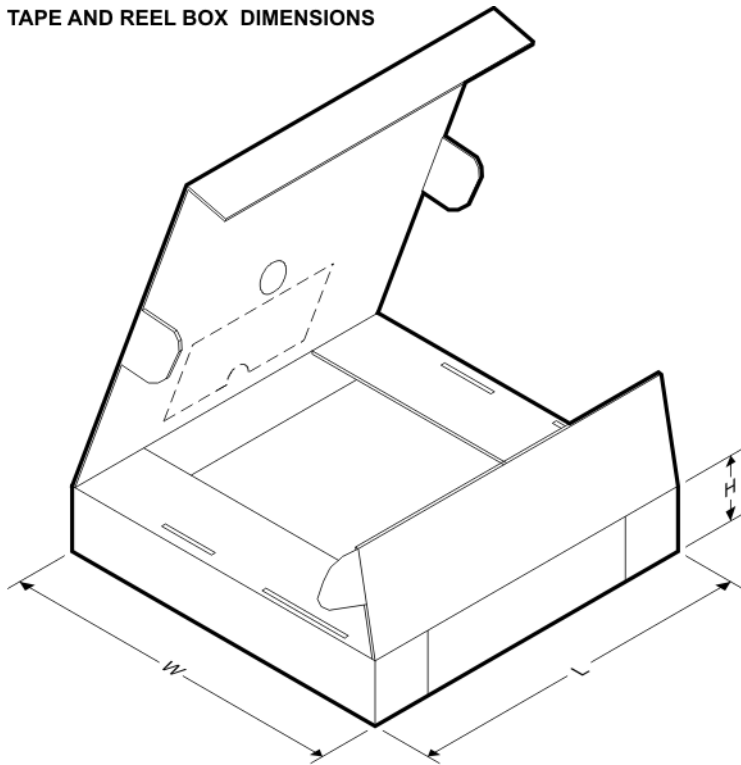

\*All dimensions are nominal

Device	Package Type	Package Drawing	Pins	SPQ	Length (mm)	Width (mm)	Height (mm)
DRV8402DKDR	SSOP	DKD	36	500	346.0	346.0	41.0



DKD (R-PDSO-G36)

PLASTIC SMALL OUTLINE

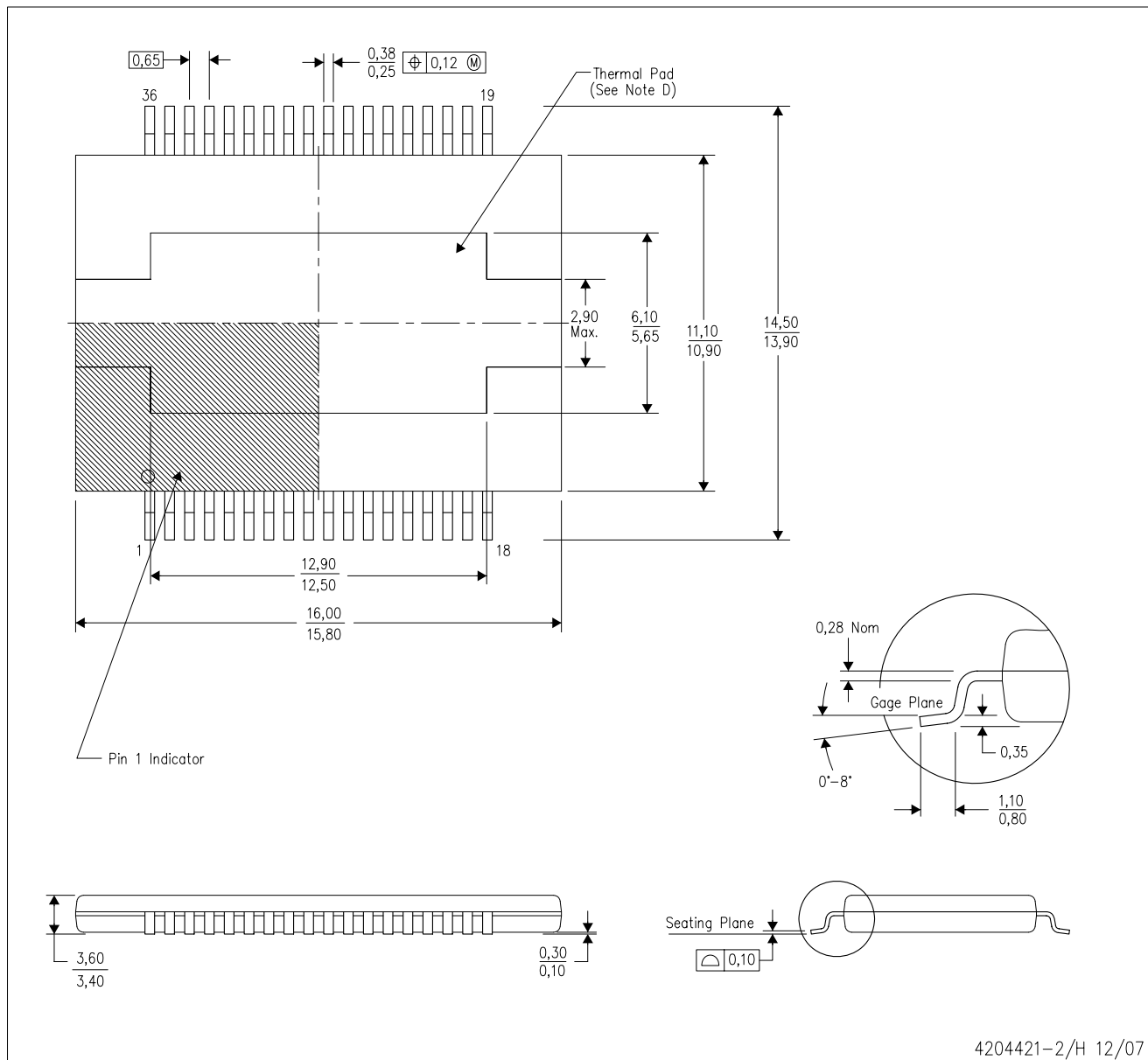

- NOTES:
- A. All linear dimensions are in millimeters.
  - B. This drawing is subject to change without notice.
  - C. Body dimensions do not include mold flash or protrusion not to exceed 0.15mm.
  - D. The package thermal performance is optimized for conductive cooling with attachment to an external heat sink. See the product data sheet for details regarding the exposed thermal pad dimensions.

## IMPORTANT NOTICE

Texas Instruments Incorporated and its subsidiaries (TI) reserve the right to make corrections, modifications, enhancements, improvements, and other changes to its products and services at any time and to discontinue any product or service without notice. Customers should obtain the latest relevant information before placing orders and should verify that such information is current and complete. All products are sold subject to TI's terms and conditions of sale supplied at the time of order acknowledgment.

TI warrants performance of its hardware products to the specifications applicable at the time of sale in accordance with TI's standard warranty. Testing and other quality control techniques are used to the extent TI deems necessary to support this warranty. Except where mandated by government requirements, testing of all parameters of each product is not necessarily performed.

TI assumes no liability for applications assistance or customer product design. Customers are responsible for their products and applications using TI components. To minimize the risks associated with customer products and applications, customers should provide adequate design and operating safeguards.

TI does not warrant or represent that any license, either express or implied, is granted under any TI patent right, copyright, mask work right, or other TI intellectual property right relating to any combination, machine, or process in which TI products or services are used. Information published by TI regarding third-party products or services does not constitute a license from TI to use such products or services or a warranty or endorsement thereof. Use of such information may require a license from a third party under the patents or other intellectual property of the third party, or a license from TI under the patents or other intellectual property of TI.

Reproduction of TI information in TI data books or data sheets is permissible only if reproduction is without alteration and is accompanied by all associated warranties, conditions, limitations, and notices. Reproduction of this information with alteration is an unfair and deceptive business practice. TI is not responsible or liable for such altered documentation. Information of third parties may be subject to additional restrictions.

Resale of TI products or services with statements different from or beyond the parameters stated by TI for that product or service voids all express and any implied warranties for the associated TI product or service and is an unfair and deceptive business practice. TI is not responsible or liable for any such statements.

TI products are not authorized for use in safety-critical applications (such as life support) where a failure of the TI product would reasonably be expected to cause severe personal injury or death, unless officers of the parties have executed an agreement specifically governing such use. Buyers represent that they have all necessary expertise in the safety and regulatory ramifications of their applications, and acknowledge and agree that they are solely responsible for all legal, regulatory and safety-related requirements concerning their products and any use of TI products in such safety-critical applications, notwithstanding any applications-related information or support that may be provided by TI. Further, Buyers must fully indemnify TI and its representatives against any damages arising out of the use of TI products in such safety-critical applications.

TI products are neither designed nor intended for use in military/aerospace applications or environments unless the TI products are specifically designated by TI as military-grade or "enhanced plastic." Only products designated by TI as military-grade meet military specifications. Buyers acknowledge and agree that any such use of TI products which TI has not designated as military-grade is solely at the Buyer's risk, and that they are solely responsible for compliance with all legal and regulatory requirements in connection with such use.

TI products are neither designed nor intended for use in automotive applications or environments unless the specific TI products are designated by TI as compliant with ISO/TS 16949 requirements. Buyers acknowledge and agree that, if they use any non-designated products in automotive applications, TI will not be responsible for any failure to meet such requirements.

Following are URLs where you can obtain information on other Texas Instruments products and application solutions:

### Products

Amplifiers	<a href="http://amplifier.ti.com">amplifier.ti.com</a>
Data Converters	<a href="http://dataconverter.ti.com">dataconverter.ti.com</a>
DLP® Products	<a href="http://www.dlp.com">www.dlp.com</a>
DSP	<a href="http://dsp.ti.com">dsp.ti.com</a>
Clocks and Timers	<a href="http://www.ti.com/clocks">www.ti.com/clocks</a>
Interface	<a href="http://interface.ti.com">interface.ti.com</a>
Logic	<a href="http://logic.ti.com">logic.ti.com</a>
Power Mgmt	<a href="http://power.ti.com">power.ti.com</a>
Microcontrollers	<a href="http://microcontroller.ti.com">microcontroller.ti.com</a>
RFID	<a href="http://www.ti-rfid.com">www.ti-rfid.com</a>
RF/IF and ZigBee® Solutions	<a href="http://www.ti.com/lprf">www.ti.com/lprf</a>

### Applications

Audio	<a href="http://www.ti.com/audio">www.ti.com/audio</a>
Automotive	<a href="http://www.ti.com/automotive">www.ti.com/automotive</a>
Broadband	<a href="http://www.ti.com/broadband">www.ti.com/broadband</a>
Digital Control	<a href="http://www.ti.com/digitalcontrol">www.ti.com/digitalcontrol</a>
Medical	<a href="http://www.ti.com/medical">www.ti.com/medical</a>
Military	<a href="http://www.ti.com/military">www.ti.com/military</a>
Optical Networking	<a href="http://www.ti.com/opticalnetwork">www.ti.com/opticalnetwork</a>
Security	<a href="http://www.ti.com/security">www.ti.com/security</a>
Telephony	<a href="http://www.ti.com/telephony">www.ti.com/telephony</a>
Video & Imaging	<a href="http://www.ti.com/video">www.ti.com/video</a>
Wireless	<a href="http://www.ti.com/wireless">www.ti.com/wireless</a>

Mailing Address: Texas Instruments, Post Office Box 655303, Dallas, Texas 75265  
Copyright © 2009, Texas Instruments Incorporated