



DAC1220

For most current data sheet and other product information, visit [www.burr-brown.com](http://www.burr-brown.com)

## 20-Bit Low Power DIGITAL-TO-ANALOG CONVERTER

### FEATURES

- 20-BIT MONOTONICITY GUARANTEED OVER  $-40^{\circ}\text{C}$  to  $+85^{\circ}\text{C}$
- LOW POWER: 2.5mW
- VOLTAGE OUTPUT
- SETTLING TIME: 2ms to 0.012%
- MAX LINEARITY ERROR:  $\pm 0.0015\%$
- ON-CHIP CALIBRATION

### APPLICATIONS

- PROCESS CONTROL
- ATE PIN ELECTRONICS
- CLOSED-LOOP SERVO-CONTROL
- SMART TRANSMITTERS
- PORTABLE INSTRUMENTS

### DESCRIPTION

The DAC1220 is a 20-bit digital-to-analog (D/A) converter offering 20-bit monotonic performance over the specified temperature range. It utilizes delta-sigma technology to achieve inherently linear performance in a small package at very-low power. The resolution of the device can be programmed to 20 bits for full-scale, settling to 0.003% within 15ms typical, or 16 bits for full-scale, settling to 0.012% within 2ms max. The output range is two times the external reference voltage. On-chip calibration circuitry dramatically reduces low offset and gain errors.

The DAC1220 features a synchronous serial interface. In single-converter applications, the serial interface can be accomplished with just two wires, allowing low-cost isolation. For multiple converters, a  $\overline{\text{CS}}$  signal allows for selection of the appropriate D/A converter.

The DAC1220 has been designed for closed-loop control applications in the industrial process control market and high-resolution applications in the test and measurement market. It is also ideal for remote applications, battery-powered instruments, and isolated systems. The DAC1220 is available in a SSOP-16 package.

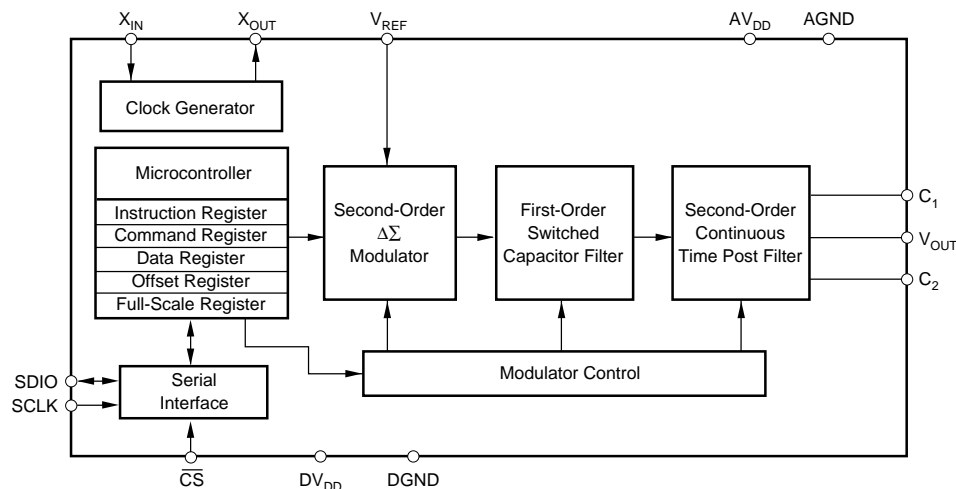

International Airport Industrial Park • Mailing Address: PO Box 11400, Tucson, AZ 85734 • Street Address: 6730 S. Tucson Blvd., Tucson, AZ 85706 • Tel: (520) 746-1111  
Twx: 910-952-1111 • Internet: <http://www.burr-brown.com/> • Cable: BBRCORP • Telex: 066-6491 • FAX: (520) 889-1510 • Immediate Product Info: (800) 548-6132

# SPECIFICATIONS

All specifications  $T_{MIN}$  to  $T_{MAX}$ ,  $AV_{DD} = DV_{DD} = +5V$ ,  $f_{XIN} = 2.5MHz$ ,  $V_{REF} = +2.5V$ , and 16-bit mode, unless otherwise noted.

PARAMETER	CONDITIONS	DAC1220E			UNITS
		MIN	TYP	MAX	
<b>ACCURACY</b>					
Monotonicity		16			Bits
Monotonicity	20-Bit Mode	20			Bits
Linearity Error				$\pm 1^{(1)}$	LSB
Unipolar Offset Error <sup>(2)</sup>	$V_{OUT} = 20mV$			$\pm 4$	LSB
Unipolar Offset Error Drift <sup>(3)</sup>			1		ppm/°C
Bipolar Zero Offset Error <sup>(2)</sup>	$V_{OUT} = V_{REF}$		$\pm 1$		LSB
Bipolar Zero Offset Drift <sup>(3)</sup>			1		ppm/°C
Gain Error <sup>(2)</sup>				$\pm 10$	LSB
Gain Error Drift <sup>(3)</sup>			2		ppm/°C
Power Supply Rejection Ratio	at DC, $dB = -20\log(\Delta V_{OUT}/\Delta V_{DD})$		60		dB
<b>ANALOG OUTPUT</b>					
Output Voltage <sup>(4)</sup>		0		$2 \cdot V_{REF}$	V
Output Current				0.5	mA
Capacitive Load			500		pF
Short-Circuit Current			$\pm 20$		mA
Short-Circuit Duration	GND or $V_{DD}$		Indefinite		
<b>DYNAMIC PERFORMANCE</b>					
Settling Time <sup>(5)</sup>	To $\pm 0.012\%$		1.8	2	ms
	20-Bit Mode, to $\pm 0.003\%$		15		ms
Output Noise Voltage	0.1Hz to 10Hz		1		$\mu V_{rms}$
<b>REFERENCE INPUT</b>					
Input Voltage		2.25	2.5	2.75	V
Input Impedance			100		k $\Omega$
<b>DIGITAL INPUT/OUTPUT</b>					
Logic Family		TTL-Compatible CMOS			
Logic Levels (all except $X_{IN}$ )				$DV_{DD} + 0.3$	V
$V_{IH}$		2.0		0.8	V
$V_{IL}$		-0.3			V
$V_{OH}$	$I_{OH} = -0.8mA$	3.6			V
$V_{OL}$	$I_{OL} = 1.6mA$			0.4	V
Input-Leakage Current				$\pm 10$	$\mu A$
$X_{IN}$ Frequency Range ( $f_{XIN}$ )		0.5		2.5	MHz
Data Format	User Programmable	Offset Two's Complement or Straight Binary			
<b>POWER SUPPLY REQUIREMENTS</b>					
Power Supply Voltage		4.75		5.25	V
Supply Current					
Analog Current			360		$\mu A$
Digital Current			140		$\mu A$
Analog Current	20-Bit Mode		460		$\mu A$
Digital Current	20-Bit Mode		140		$\mu A$
Power Dissipation			2.5	3.5	mW
	20-Bit Mode		3.0		mW
	Sleep Mode		0.45		mW
<b>TEMPERATURE RANGE</b>					
Specified Performance		-40		+85	°C

NOTES: (1) Valid from  $AGND + 20mV$  to  $AV_{DD} - 20mV$ , in the 16-bit mode. (2) Applies after calibration, in 16-bit mode. (3) Re-calibration can remove these errors. (4) Ideal output voltage, does not take into account gain and offset error. (5) Valid from  $AGND + 20mV$  to  $AV_{DD} - 20mV$ . Outside of this range, settling time may be twice the value indicated. For 16-bit mode,  $C_1 = 2.2nF$ ,  $C_2 = 0.22nF$ ; for 20-bit mode,  $C_1 = 10nF$ ,  $C_2 = 3.3nF$ .

## PIN CONFIGURATION

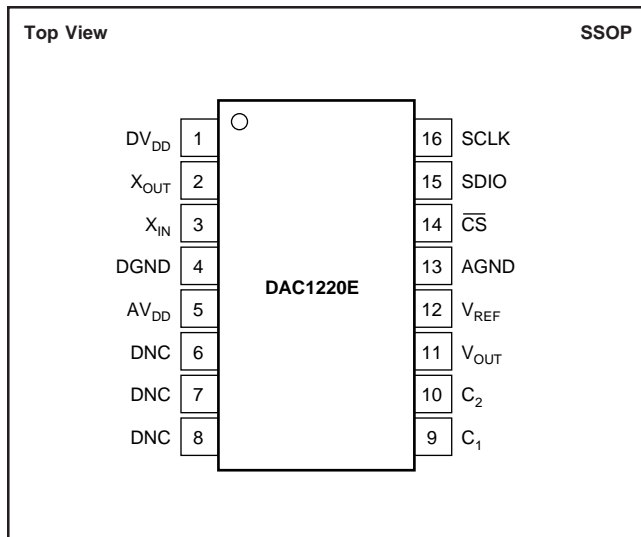

## PIN DESCRIPTIONS

PIN	NAME	DESCRIPTION
1	DV <sub>DD</sub>	Digital Supply, +5V nominal
2	X <sub>OUT</sub>	System Clock Output (for Crystal)
3	X <sub>IN</sub>	System Clock Input
4	DGND	Digital Ground
5	AV <sub>DD</sub>	Analog Supply, +5V nominal
6	DNC	Do Not Connect
7	DNC	Do Not Connect
8	DNC	Do Not Connect
9	C <sub>1</sub>	Filter Capacitor, see text.
10	C <sub>2</sub>	Filter Capacitor, see text.
11	V <sub>OUT</sub>	Analog Output Voltage
12	V <sub>REF</sub>	Reference Input
13	AGND	Analog Ground
14	$\overline{CS}$	Chip Select Input
15	SDIO	Serial Data Input/Output
16	SCLK	Clock Input for Serial Data Transfer

## ABSOLUTE MAXIMUM RATINGS<sup>(1)</sup>

AV <sub>DD</sub> to DV <sub>DD</sub> .....	±0.3V
AV <sub>DD</sub> to AGND .....	-0.3V to 6V
DV <sub>DD</sub> to DGND .....	-0.3V to 6V
AGND to DGND .....	±0.3V
V <sub>REF</sub> Voltage to AGND .....	2.0V to 3.0V
Digital Input Voltage to DGND .....	-0.3V to DV <sub>DD</sub> + 0.3V
Digital Output Voltage to DGND .....	-0.3V to DV <sub>DD</sub> + 0.3V
Package Power Dissipation .....	(T <sub>JMAX</sub> - T <sub>A</sub> )/θ <sub>JA</sub>
Maximum Junction Temperature (T <sub>JMAX</sub> ) .....	+150°C
Thermal Resistance, θ <sub>JA</sub>	
SSOP-16 .....	200°C/W
Lead Temperature (soldering, 10s) .....	+300°C

NOTE: (1) Stresses above those listed under "Absolute Maximum Ratings" may cause permanent damage to the device. Exposure to absolute maximum conditions for extended periods may affect device reliability.



## ELECTROSTATIC DISCHARGE SENSITIVITY

This integrated circuit can be damaged by ESD. Burr-Brown recommends that all integrated circuits be handled with appropriate precautions. Failure to observe proper handling and installation procedures can cause damage.

ESD damage can range from subtle performance degradation to complete device failure. Precision integrated circuits may be more susceptible to damage because very small parametric changes could cause the device not to meet its published specifications.

## PACKAGE/ORDERING INFORMATION

PRODUCT	MAXIMUM LINEARITY ERROR (LSB)	PACKAGE	PACKAGE DRAWING NUMBER	SPECIFICATION TEMPERATURE RANGE	ORDERING NUMBER <sup>(1)</sup>	TRANSPORT MEDIA
DAC1220E "	±1 "	SSOP-16 "	322 "	-40°C to +85°C "	DAC1220E DAC1220E/2K5	Rails Tape and Reel

NOTE: (1) Models with a slash (/) are available only in Tape and Reel in the quantities indicated (e.g., /2K5 indicates 2500 devices per reel). Ordering 2500 pieces of "DAC1220E/2K5" will get a single 2500-piece Tape and Reel.

The information provided herein is believed to be reliable; however, BURR-BROWN assumes no responsibility for inaccuracies or omissions. BURR-BROWN assumes no responsibility for the use of this information, and all use of such information shall be entirely at the user's own risk. Prices and specifications are subject to change without notice. No patent rights or licenses to any of the circuits described herein are implied or granted to any third party. BURR-BROWN does not authorize or warrant any BURR-BROWN product for use in life support devices and/or systems.

# TYPICAL PERFORMANCE CURVES

At  $T_A = +25^\circ\text{C}$ ,  $AV_{DD} = DV_{DD} = +5.0\text{V}$ ,  $f_{XIN} = 2.5\text{MHz}$ ,  $V_{REF} = 2.5\text{V}$ ,  $C_1 = 2.2\text{nF}$  and  $C_2 = 0.22\text{nF}$ , calibrated mode, unless otherwise specified.

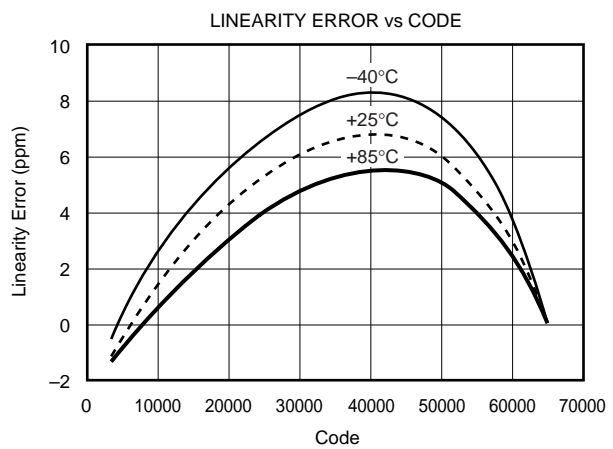
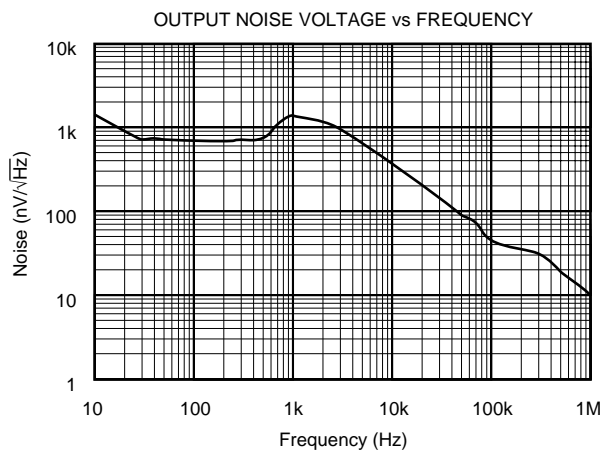
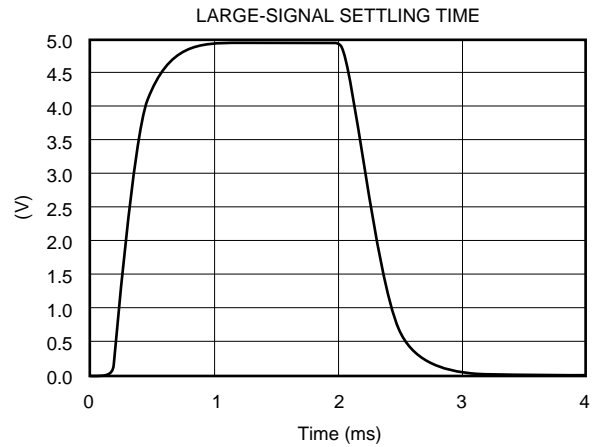
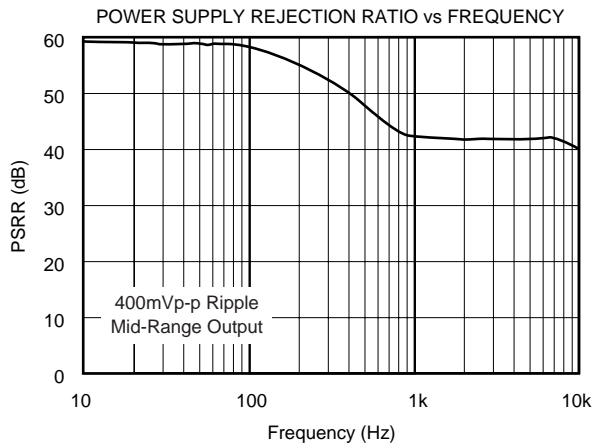

## THEORY OF OPERATION

The DAC1220 is a precision, high dynamic range, self-calibrating, 20-bit, delta-sigma digital-to-analog converter. It contains a second-order delta-sigma modulator, a first-order switched-capacitor filter, a second-order continuous-time post filter, a microcontroller including the Instruction, Command and Calibration registers, a serial interface, and a clock generator circuit.

The design topology provides low system noise and good power-supply rejection. The modulator frequency of the delta-sigma D/A converter is controlled by the system clock.

The DAC1220 also includes complete onboard calibration that can correct for internal offset and gain errors. The calibration registers are fully readable and writable. This feature allows for system calibration. The various settings, modes, and registers of the DAC1220 are read or written via a synchronous serial interface. This interface operates as an externally clocked interface.

### DEFINITION OF TERMS

**Differential Nonlinearity Error**—The differential nonlinearity error is the difference between an actual step width and the ideal value of 1 LSB. If the step width is exactly 1 LSB, the differential nonlinearity error is zero. A differential nonlinearity specification of less than 1 LSB guarantees monotonicity.

**Drift**—The drift is the change in a parameter over temperature.

**Full-Scale Range (FSR)**—This is the magnitude of the typical analog output voltage range which is  $2 \cdot V_{REF}$ . For example, when the converter is configured with a 2.5V reference, the full-scale range is 5.0V.

**Gain Error**—This error represents the difference in the slope between the actual and ideal transfer functions.

**Linearity Error**—The linearity error is the deviation of the actual transfer function from an ideal straight line between the data end points.

**Least Significant Bit (LSB) Weight**—This is the ideal change in voltage that the analog output will change with a change in the digital input code of 1 LSB.

**Monotonicity**—Monotonicity assures that the analog output will increase or stay the same for increasing digital input codes.

**Offset Error**—The offset error is the difference between the expected and actual output, when the output is zero. The value is calculated from measurements made when  $V_{OUT} = 20\text{mV}$ .

**Settling Time**—The settling time is the time it takes the output to settle to its new value after the digital code has been changed.

$f_{XIN}$ —The frequency of the crystal oscillator or CMOS-compatible input signal at the  $X_{IN}$  input of the DAC1220.

## ANALOG OPERATION

The system clock is divided down to provide the sample clock for the modulator. The sample clock is used by the modulator to convert the multi-bit digital input into a one-bit digital output stream. The use of a 1-bit DAC provides inherent linearity. The digital output stream is then converted into an analog signal via the 1-bit DAC and then filtered by the 1st-order switched capacitor filter.

The output of the switched-capacitor filter feeds into the continuous time filter. The continuous time filter uses external capacitors connected between the  $C_1$ ,  $C_2$ ,  $V_{REF}$ , and  $V_{OUT}$  pins to adjust the settling time. The connections for the capacitors are shown in Figure 1 ( $C_1$  connects between the  $V_{REF}$  and  $C_1$  pins, and  $C_2$  connects between the  $V_{OUT}$  and  $C_2$  pins).

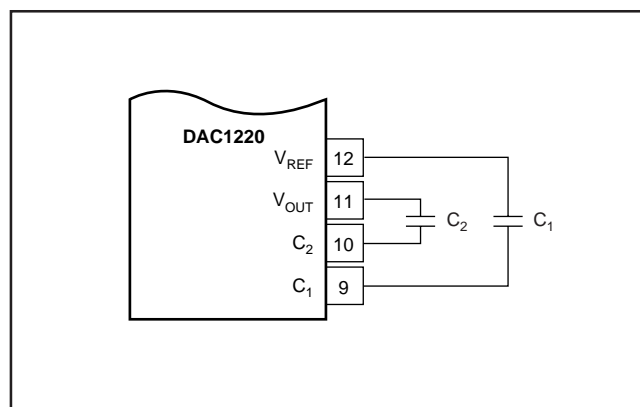

FIGURE 1. External Capacitor Connections.

CAPACITOR	16-BIT MODE	20-BIT MODE
$C_1$	2.2nF	10nF
$C_2$	0.22nF	3.3nF

TABLE I. External Capacitor Values.

### CALIBRATION

The DAC1220 offers a self-calibration mode which automatically calibrates the output offset and gain. The calibration is performed once and then normal operation is resumed. In general, calibration is recommended immediately after power-on and whenever there is a “significant” change in the operating environment. The amount of change which should cause a re-calibration is dependent on the application. Where high accuracy is important, re-calibration should be done on changes in temperature and power supply.

After a calibration has been accomplished, the Offset Calibration Register (OCR) and the Full-Scale Calibration Register (FCR) contain the results of the calibration.

Note that the values in the calibration registers will vary from configuration-to-configuration and from part to part.

## Self-Calibration

A self-calibration is performed after the bits “01” have been written to the Command Register Operation Mode bits (MD1 through MD0) and a “1” has been written to the Command Register sample-and-hold bit (SH). This initiates a self-calibration on the next clock cycle. The offset correction code is determined by a repeated sequence of auto-zeroing the calibration comparator to the offset reference value. The end result is then averaged, Offset Two’s Complement adjusted, and placed in the OCR. The gain correction is done in a similar fashion except the correction is done against  $V_{REF}$  to eliminate common-mode errors. The FCR result represents the gain code and is not Offset Two’s Complement adjusted.

The calibration function takes between 300ms and 500ms to complete (for  $f_{XIN} = 2.5\text{MHz}$ ). Once calibration is initiated, further writing of register bits is disabled until calibration completes. The status of calibration can be verified by reading the status of the Command Register Operation Mode bits (MD1 through MD0). These bits will return to normal mode “00” when calibration is complete.

Self-calibration can be done with the output isolated or connected. This is done by setting (output connected) or clearing (output isolated) the CALPIN bit in the CMR register.

## Output Mode

The DAC1220 can operate in either 16-bit mode or 20-bit mode. The mode is determined by setting (20-bit) or clearing (16-bit) the RES bit in the CMR register.

The output of the DAC1220 can be synchronously reset. By setting the CLR bit in the CMR, the data input register is cleared to zero. This will result in an output of 0V when  $DF = 1$  or  $V_{REF}$  when  $DF = 0$ , assuming no calibration errors.

The settling time is determined by the DISF, RES, and ADPT bits of the command register. The default state of  $DISF = 0$  and  $ADPT = 0$  enables fast settling, unless the output step is small ( $\approx 40\text{mV}$ ). However, the DAC1220 can be forced to always use fast settling if the ADPT bit is set to 1. If DISF is set to 1, all fast settling is disabled.

The SH bit of the CMR register determines if  $C_2$  is internally connected to  $V_{REF}$ . By clearing the SH bit,  $C_2$  is disconnected from  $V_{REF}$ .

The CRST bit of the CMR register can be used to reset the offset and calibration registers. By setting the CRST bit, the contents of the calibration register are reset to 0.

## REFERENCE INPUT

The reference input voltage of 2.5V can be directly connected to  $V_{REF}$ .

The recommended reference circuit for the DAC1220 is shown in Figure 2.

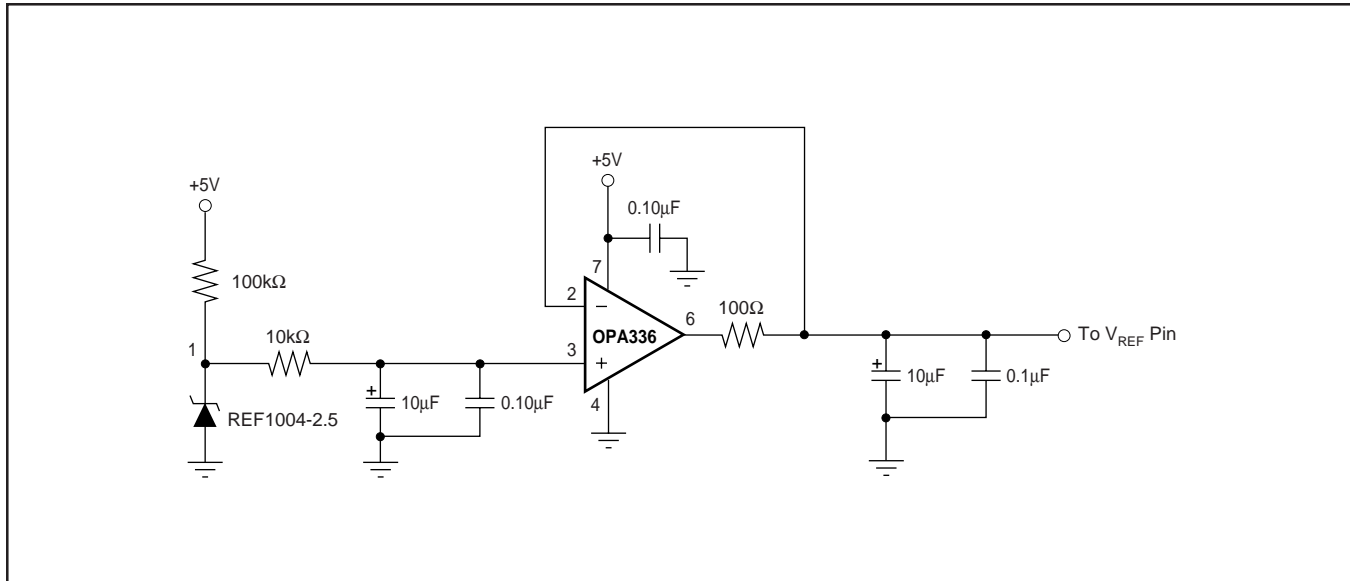

FIGURE 2. Recommended External Voltage Reference Circuit for Best Low Noise Operation with the DAC1220.

# DIGITAL OPERATION

## SYSTEM CONFIGURATION

The DAC1220 is controlled by 8-bit instruction codes (INSR) and 16-bit command codes (CMR) via the serial interface, which is externally clocked.

The DAC1220 Microcontroller (MC) consists of an ALU and a register bank. The MC has three states: power-on reset, calibration, and normal operation. In the power-on reset state, the MC resets all the registers to their default states. In the calibration state, the MC performs offset and gain self-calibration. In the normal state, the MC performs D/A conversions.

The DAC1220 has five internal registers, as shown in Table II. Two of these, the Instruction Register (INSR) and the Command Register (CMR), control the operation of the converter. The Instruction register utilizes an 8-bit instruction code to control the serial interface to determine whether the next operation is either a read or a write, to control the word length and to select the appropriate register to read/write. Communication with the DAC1220 is controlled via the INSR. The INSR is written as the first part of each serial communication. The instruction that is sent determines what type of communication will occur next. It is not possible to read the INSR. The Command register has a 16-bit command code to set up the DAC1220 operation mode, resolution mode, settling mode and data format. The Data Input Register (DIR) contains the value for the next conversion. The Offset and Full-Scale Calibration Registers (OCR and FCR) contain data used for correcting the internal conversion value after it is placed into the DIR. The data in these two registers may be the result of a calibration routine, or they may be values which have been written directly via the serial interface.

INSR	Instruction Register	8 Bits
DIR	Data Input Register	24 Bits
CMR	Command Register	16 Bits
OCR	Offset Calibration Register	24 Bits
FCR	Full-Scale Calibration Register	24 Bits

TABLE II. DAC1220 Registers.

### Instruction Register (INSR)

Each serial communication starts with the 8 bits of the INSR being sent to the DAC1220. The read/write bit, the number of bytes n, and the starting register address are defined, as shown in Table III. When the n bytes have been transferred, the instruction is complete. A new communication cycle is initiated by sending a new INSR (under restrictions outlined in the Interfacing section).

MSB				LSB			
R/W	MB1	MB0	0	A3	A3	A1	A0

TABLE III. Instruction Register.

**R/W (Read/Write) Bit**—For a write operation to occur, this bit of the INSR must be 0. For a read, this bit must be 1, as follows:

R/W	
0	Write
1	Read

**MB1, MB0 (Multiple Bytes) Bits**—These two bits are used to control the word length (number of bytes) of the read or write operation, as follows:

MB1	MB0	
0	0	1 Byte
0	1	2 Bytes
1	0	3 Bytes

**A3 – A0 (Address) Bits**—These four bits select the beginning register location that will be read from or written to, as shown in Table III. Each subsequent byte will be read from or written to the next higher location (increment address). If the BD bit in the Command register is set, each subsequent byte will be read from or written to the next lower location (decrement address). This bit does not affect INSR register or the write operation for the CMR register. If the next location is reserved in Table III, the results are unknown. Reading or writing continues until the number of bytes specified by MB1 and MB0 have been transferred.

A3	A2	A1	A0	
0	0	0	0	Data Input Register Byte 2 MSB
0	0	0	1	Data Input Register Byte 1
0	0	1	0	Data Input Register Byte 0 LSB
0	0	1	1	Reserved
0	1	0	0	Command Register Byte 1 MSB
0	1	0	1	Command Register Byte 0 LSB
0	1	1	0	Reserved
0	1	1	1	Reserved
1	0	0	0	Offset Cal Register Byte 2 MSB
1	0	0	1	Offset Cal Register Byte 1
1	0	1	0	Offset Cal Register Byte 0 LSB
1	0	1	1	Reserved
1	1	0	0	Full-Scale Cal Register Byte 2 MSB
1	1	0	1	Full-Scale Cal Register Byte 1
1	1	1	0	Full-Scale Cal Register Byte 0 LSB
1	1	1	1	Reserved

TABLE IV. A3 - A0 Addressing.

## Command Register (CMR)

The CMR controls all of the functionality of the DAC1220. The new configuration is latched in on the negative transition of SCLK for the last bit of the last byte of data being written to the command register. The organization of the CMR is comprised of 16 bits of information in 2 bytes of 8 bits each.

MSB				Byte 1				Byte 0				LSB			
ADPT	CALPIN	SH	0	1	0	CRST	0	RES	CLR	DF	DISF	BD	MSB	MD1	MD0

**NOTE:** In order to obtain optimal performance, the default bit states for the Command Register should be used (refer to Table VI). The only exception is the SH bit—the default bit state is 0, however, the bit should be set to 1 for optimal performance.

TABLE V. Command Register.

**ADPT (Adaptive Filter Disable) Bit**—The ADPT bit determines if the adaptive filter is enabled or disabled. When the Adaptive Filter is enabled, the DAC1220 does fast settling only when there is an output step of larger than  $\approx 40\text{mV}$ . For small changes in the data, fast settling is not necessary. When  $\text{ADPT} = 1$ , the Adaptive Filter is disabled and the DAC1220 will not look at the size of a step to determine the necessity of using fast settling. In either case, fast settling can be defeated if  $\text{DISF} = 1$ .

ADPT	
0	Enabled (default)
1	Disabled

**CALPIN (Calibration Pin) Bit**—The Calibration Pin bit determines if the output is isolated or connected during calibration.

CALPIN		
0	Output Isolated	Default
1	Output Connected	

**SH (Sample/Hold) Bit** —The Sample-and-Hold bit determines if  $C_2$  is internally connected to  $V_{\text{REF}}$ . For best performance, it is recommended to set this bit to 1.

SH		
0	Disconnected	Default
1	Connected	Recommended

**CRST (Calibration Reset) Bit**—The CRST bit resets the offset and full-scale calibration registers.

CRST		
0	OFF	Default
1	Reset	

**RES (Resolution) Bit**—The Resolution bit selects either 16-bit or 20-bit resolution.

RES		
0	16-Bit	Default
1	20-Bit	

**CLR (Clear) Bit**—The CLR bit synchronously resets the data input register to zero. The analog output will be based on the DF bit—if 1, the output will be  $0\text{V}$ ; if 0, the output will be  $V_{\text{REF}}$ .

CLR		
0	OFF	Default
1	ON	

**DF (Data Format) Bit**—The DF bit controls the format of the input data, shown in hexadecimal (either Offset Two's Complement or Straight Binary), as shown:

Input Code		$V_{\text{OUT}}$
Offset Two's Complement DF = 0 (default)	Straight Binary DF = 1	
8000	0000	0
0000	8000	$V_{\text{REF}}$
7FFF	FFFF	$2 \cdot V_{\text{REF}}$

**DISF (Disable Fast Settling) Bit**—The DISF bit disables the fast settling option. If this bit is zero, the fast settling performance is determined by the ADPT bit, the RES bit, and the ADPT bit.

DISF	
0	Fast Settling (default)
1	Disable Fast Settling

**BD (Byte Order) Bit**—The BD bit controls the order in which bytes of data are transferred (either most significant byte first (MSBF) or least significant byte first (LSBF)), as shown:

BD bit:	0 (default)	1	0 (default)	1
<i>register</i>	read		write	
INSR	write only	write only	MSBF	MSBF
CMR	MSBF	LSBF	MSBF	MSBF
DIR	MSBF	LSBF	MSBF	LSBF
OCR	MSBF	LSBF	MSBF	LSBF
FCR	MSBF	LSBF	MSBF	LSBF

Care must be observed in reading the Command Register if the state of the BD bit is unknown. If a two byte read is started at address 0100 with  $\text{BD} = 0$ , it will read the contents at address 0100, then 0101. However, if  $\text{BD} = 1$ , it will read from 0100, then 0011. If the BD bit is unknown, all reads of the command register are best performed as read commands of one byte.



**MSB (Bit Order) Bit**—The MSB bit controls the order in which bits within a byte of data are read or written (either most significant bit first or least significant bit first) as follows:

MSB		
0	MSB-First	Default
1	LSB-First	

**MD1 - MD0 (Operating Mode) Bits**—The Operating Mode bits control the calibration functions of the DAC1220. The Normal mode is used to perform conversions. The Self-Calibration mode is a one-step calibration sequence that calibrates both the offset and full scale.

MD1	MD0	
0	0	Normal Mode
0	1	Self-Cal
1	0	Sleep
1	1	X

### Offset Calibration Register (OCR)

The OCR is a 24-bit register containing the offset correction factor that is used to apply a correction to the digital input before it is transferred to the modulator. The results of the self-calibration process will be written to this register.

The OCR is both readable and writable via the serial interface. For applications requiring a more accurate calibration, a calibration can be performed, the results averaged, and a more precise offset calibration value written back to the OCR.

The actual OCR value after calibration will change from part to part and with configuration, temperature, and power supply. In addition, be aware that the contents of the OCR are not used to directly correct the digital input. Rather, the correction is a function of the OCR value. This function is linear and two known points can be used as a basis for interpolating intermediate values for the OCR.

The results of calibration are averaged, Offset Two's Complement adjusted, and placed in the OCR.

MSB			Byte 2				
OCR23	OCR22	OCR21	OCR20	OCR19	OCR18	OCR17	OCR16
Byte 1							
OCR15	OCR14	OCR13	OCR12	OCR11	OCR10	OCR9	OCR8
Byte 0				LSB			
OCR7	OCR6	OCR5	OCR4	OCR3	OCR2	OCR1	OCR0

TABLE VI. Offset Calibration Register.

### Full-Scale Calibration Register (FCR)

The FCR is a 24-bit register which contains the full-scale correction factor that is applied to the digital input before it is transferred to the modulator. The contents of this register will be the result of a self-calibration, or written to by the user.

The FCR is both readable and writable via the serial interface. For applications requiring an accurate system calibration, a system calibration can be performed, the results averaged, and a more precise value written back to the FCR.

The actual FCR value after calibration will change from part to part and with configuration, temperature, and power supply.

In addition, be aware that the contents of the FCR are not used to directly correct the digital input. Rather, the correction is a function of the FCR value. This function is linear and two known points can be used as a basis for interpolating intermediate values for the FCR. The contents of the FCR are in unsigned binary format. This is not affected by the DF bit in the Command register.

MSB			Byte 2				
FCR23	FCR22	FCR21	FCR20	FCR19	FCR18	FCR17	FCR16
Byte 1							
FCR15	FCR14	FCR13	FCR12	FCR11	FCR10	FCR9	FCR8
Byte 0				LSB			
FCR7	FCR6	FCR5	FCR4	FCR3	FCR2	FCR1	FCR0

TABLE VII. Full-Scale Calibration Register.

### Data Input Register (DIR)

The DIR is a 24-bit register which contains the digital input value (see Table VIII). The register is latched on the falling edge of the last bit of the last byte sent. The contents of the DIR are then loaded into the modulator. This means that the DIR register can be updated after sending 1, 2, or 3 bytes, which is determined by the MB1 and MB0 bits in the Instruction Register. The contents of the DIR can be Offset Two's Complement or Straight Binary.

MSB			Byte 2				
DIR23	DIR22	DIR21	DIR20	DIR19	DIR18	DIR17	DIR16
Byte 1							
DIR15	DIR14	DIR13	DIR12	DIR11	DIR10	DIR9	DIR8
Byte 0				LSB			
DIR7	DIR6	DIR5	DIR4	DIR3	DIR2	DIR1	DIR0

TABLE VIII. Data Input Register.

## SLEEP MODE

The Sleep Mode is entered after the bit combination 10 has been written to the CMR Operation Mode bits (MD1 and MD0). This mode ends when these bits are changed to a value other than 10.

Communication with the DAC1220 can continue during Sleep Mode. When a new mode (other than Sleep) has been entered, the DAC1220 will execute a very brief internal power-up sequence of the analog and digital circuitry. In addition, the settling of the external  $V_{REF}$  and other circuitry must be taken into account to determine the amount of time required to resume normal operation.

The output is turned off in sleep mode.

## SERIAL INTERFACE

The DAC1220 includes a flexible serial interface which can be connected to microcontrollers and digital signal processors in a variety of ways. Along with this flexibility, there is also a good deal of complexity. This section describes the trade-offs between the different types of interfacing methods in a top-down approach—starting with the overall flow and control of serial data, moving to specific interface examples, and then providing information on various issues related to the serial interface.

## Reset, Power-On Reset and Brown-Out

The DAC1220 contains an internal power-on reset circuit. If the power supply ramp rate is greater than 50mV/ms, this circuit will be adequate to ensure the device powers up correctly. Due to oscillator settling considerations, communication to and from the DAC1220 should not occur for at least 25ms after power is stable.

If this requirement cannot be met or if the circuit has brown-out considerations, the timing diagram of Figure 3 can be used to reset the DAC1220. This accomplishes the reset by controlling the duty cycle of the SCLK input.

Sleep mode is the default state after power on or reset. The output is high impedance during sleep mode.

## I/O Recovery

If serial communication stops during an instruction or data transfer for longer than 100ms (for  $f_{XIN} = 2.5\text{MHz}$ ), the DAC1220 will reset its serial interface. This will not affect the internal registers. The main controller must not continue the transfer after this event, but must restart the transfer from the beginning. This feature is very useful if the main controller can be reset at any point. After reset, simply wait 200ms (for  $f_{XIN} = 2.5\text{MHz}$ ) before starting serial communication.

## Isolation

The serial interface of the DAC1220 provides for simple isolation methods. An example of an isolated two-wire interface is shown in Figure 4.

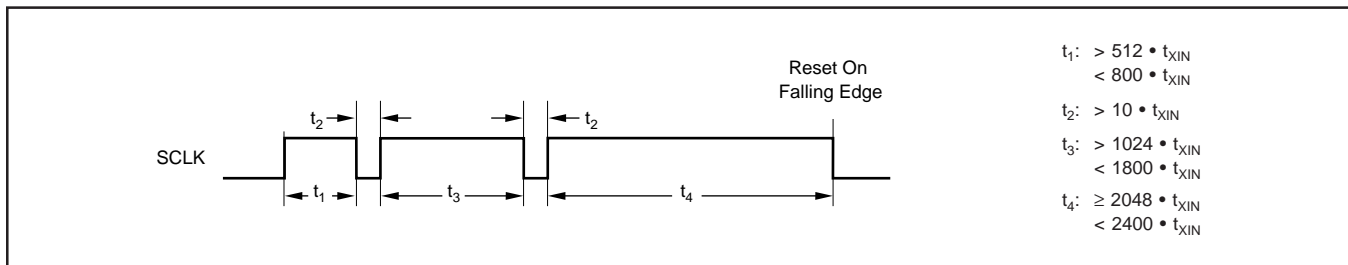

FIGURE 3. Resetting the DAC1220.

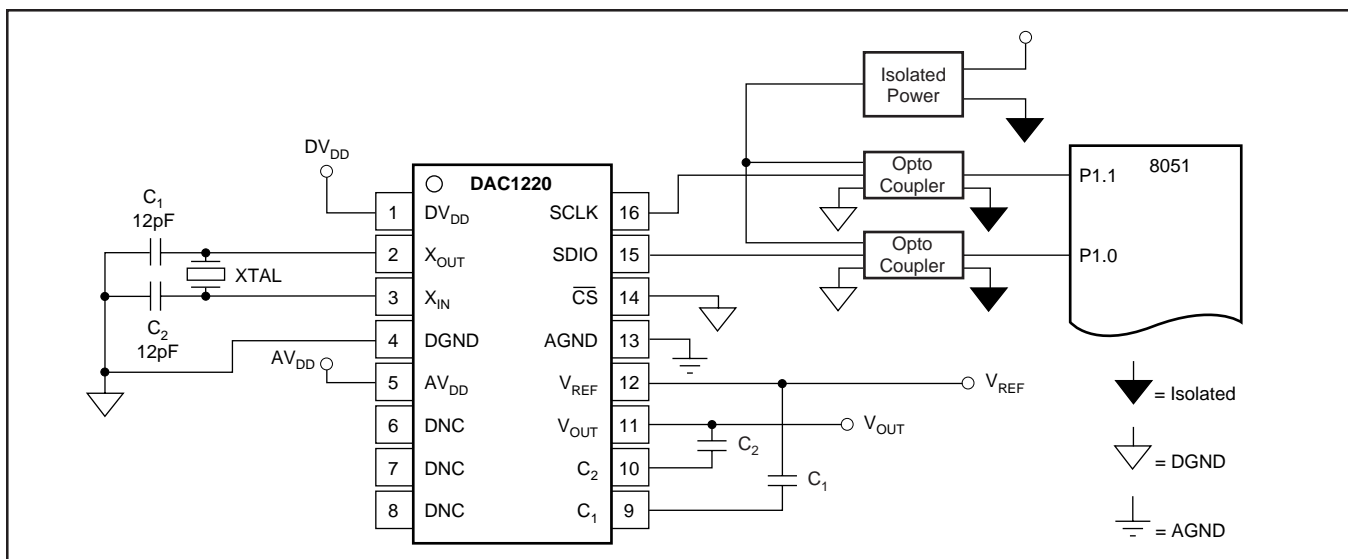

FIGURE 4. Isolation for Two-Wire Interface

## Using $\overline{CS}$

The serial interface may make use of the  $\overline{CS}$  signal, or this input may simply be tied LOW. There are several issues associated with choosing to do one or the other. The  $\overline{CS}$  signal does not directly control the tri-state condition of the SDIO output. These signals are normally in the tri-state condition. They only become active when serial data is being transmitted from the DAC1220. If the DAC1220 is in the middle of a serial transfer and the SDIO is an output, taking  $\overline{CS}$  HIGH will not tri-state the output signal.

If there are multiple serial peripherals utilizing the same serial I/O lines and communication may occur with any peripheral at any time, the  $\overline{CS}$  signal must be used. The  $\overline{CS}$  signal is then used to enable communication with the DAC1220.

## TIMING

The maximum serial clock frequency cannot exceed the DAC1220  $X_{IN}$  frequency divided by 10. Table IX and Figures 5 through 9 define the basic digital timing characteristics of the DAC1220. Figure 5 and the associated timing symbols apply to the  $X_{IN}$  input signal. Figures 6 through 9 and associated timing symbols apply to the serial interface signals (SCLK, SDIO, and  $\overline{CS}$ ). The serial interface is discussed in detail in the Serial Interface section.

SYMBOL	DESCRIPTION	MIN	NOM	MAX	UNITS
$f_{XIN}$	$X_{IN}$ Clock Frequency	1		2.5	MHz
$t_{XIN}$	$X_{IN}$ Clock Period	400		1000	ns
$t_1$	$X_{IN}$ Clock High	$0.4 \cdot t_{XIN}$			ns
$t_2$	$X_{IN}$ Clock LOW	$0.4 \cdot t_{XIN}$			ns
$t_3$	SCLK HIGH	$5 \cdot t_{XIN}$			ns
$t_4$	SCLK LOW	$5 \cdot t_{XIN}$			ns
$t_5$	Data In Valid to SCLK Falling Edge (Setup)	40			ns
$t_6$	SCLK Falling Edge to Data In Not Valid (Hold)	20			ns
$t_7$	Data Out Valid After Rising Edge of SCLK (Hold)	0			ns
$t_8$	SCLK Rising Edge to New Data Out Valid (Delay) <sup>(1)</sup>			50	ns
$t_9$	Falling Edge of Last SCLK for INSR to Rising Edge of First SCLK for Register Data	$13 \cdot t_{XIN}$			ns
$t_{10}$	Falling Edge of $\overline{CS}$ to Rising Edge of SCLK	$11 \cdot t_{XIN}$			ns
$t_{11}$	Falling Edge of Last SCLK for INSR to SDIO as Output	$8 \cdot t_{XIN}$		$10 \cdot t_{XIN}$	ns
$t_{12}$	SDIO as Output to Rising Edge of First SCLK for Register Data		$4 \cdot t_{XIN}$		ns
$t_{13}$	Falling Edge of Last SCLK for Register Data to SDIO Tri-State	$4 \cdot t_{XIN}$		$6 \cdot t_{XIN}$	ns
$t_{14}$	Falling Edge of Last SCLK for Register Data to Rising Edge of First SCLK of next INSR ( $\overline{CS}$ Tied LOW)	$41 \cdot t_{XIN}$			ns
$t_{15}$	Rising Edge of $\overline{CS}$ to Falling Edge of $\overline{CS}$ (Using $\overline{CS}$ )	$22 \cdot t_{XIN}$			ns

NOTE: (1) With 10pF load.

TABLE IX. Digital Timing Characteristics.

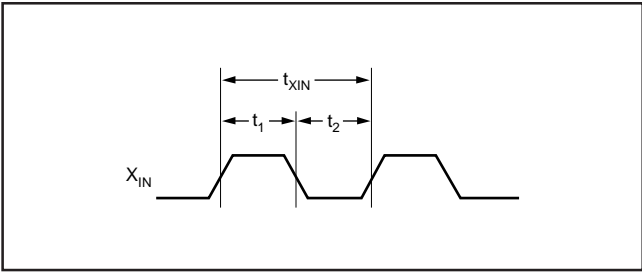

FIGURE 5.  $X_{IN}$  Clock Timing.

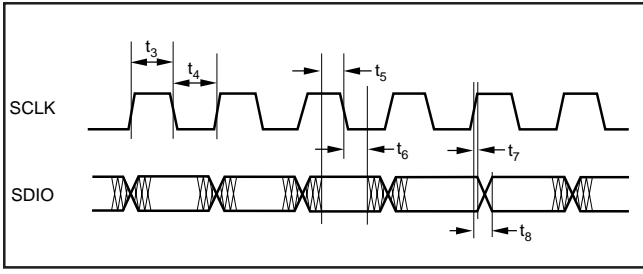

FIGURE 6. Serial Input/Output Timing.

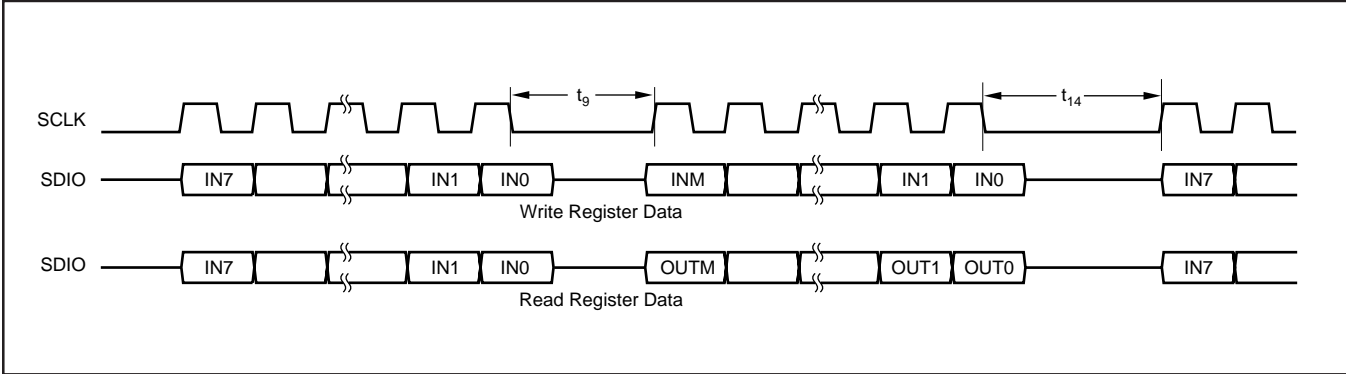

FIGURE 7. Serial Interface Timing ( $\overline{CS}$  LOW).

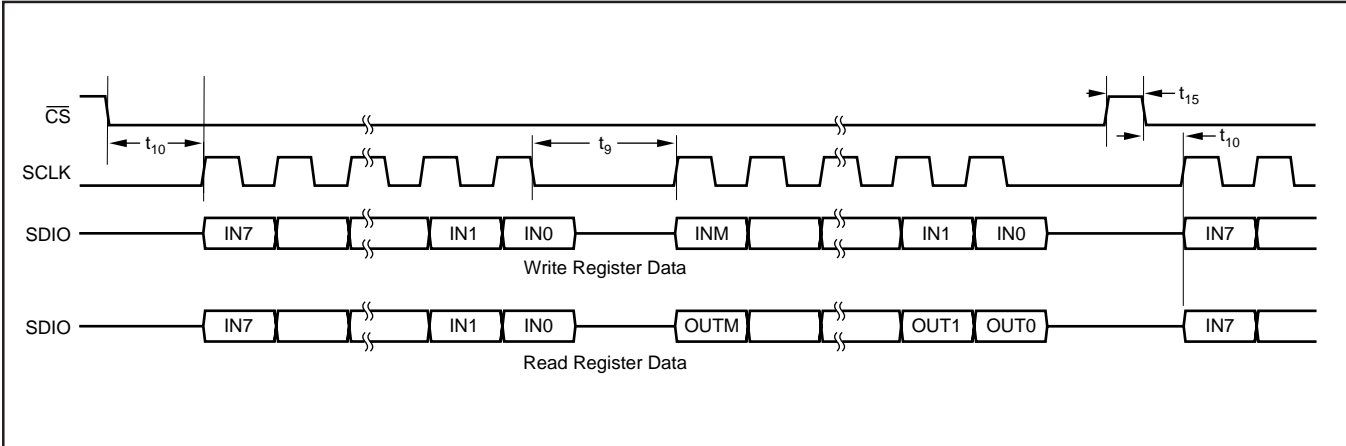

FIGURE 8. Serial Interface Timing (using  $\overline{CS}$ ).

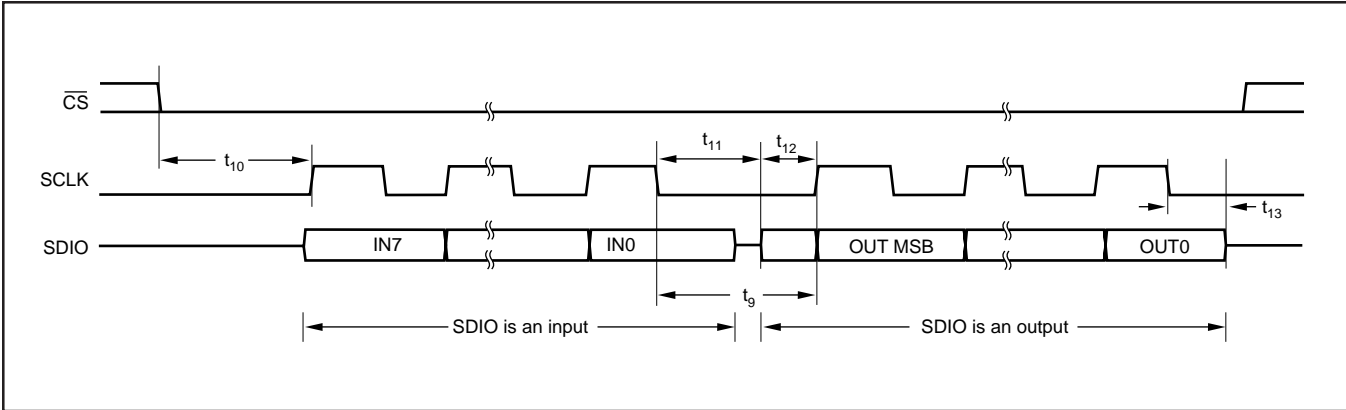

FIGURE 9. SDIO Input to Output Transition Timing.

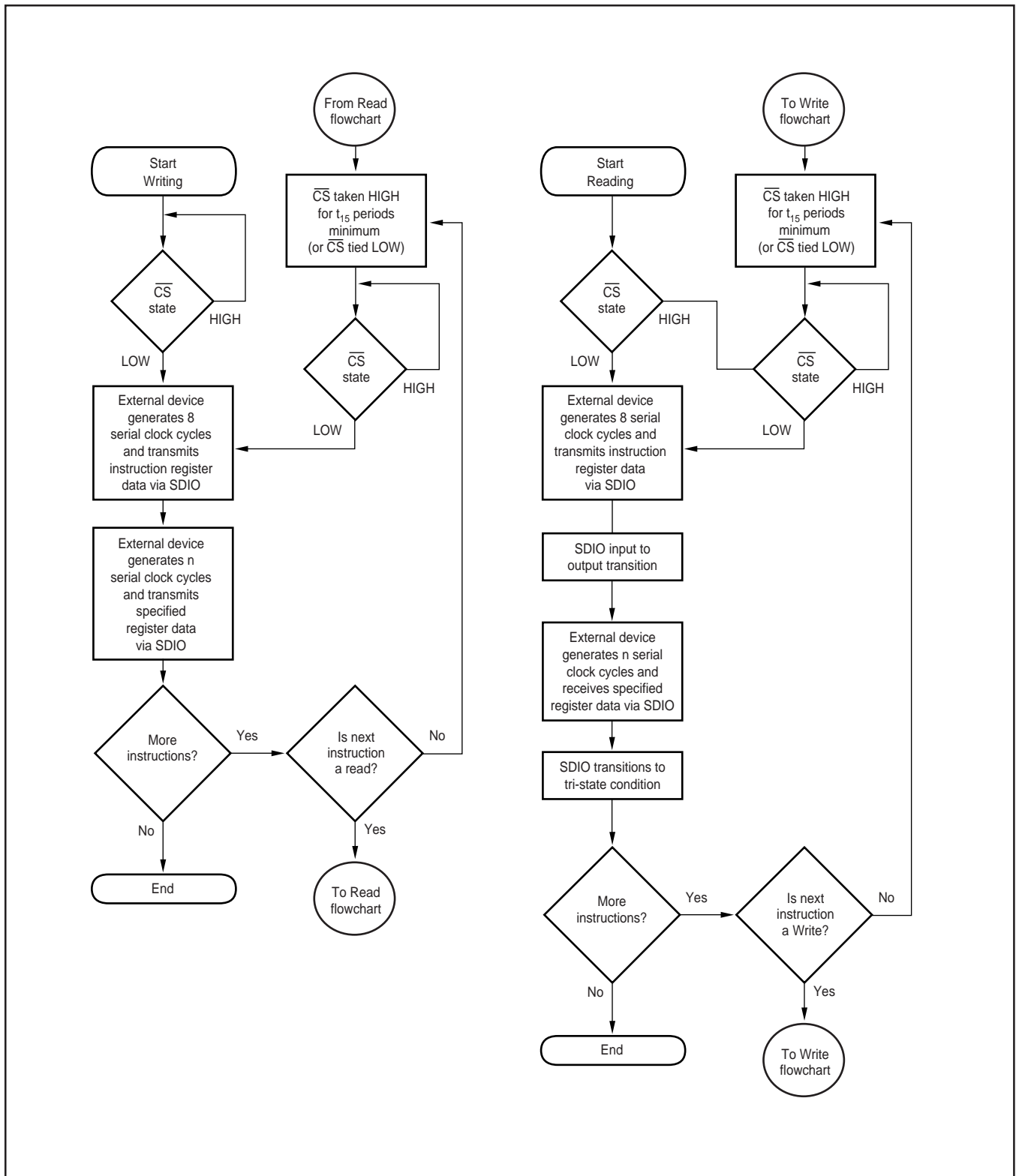

FIGURE 10. Flowchart for Writing and Reading Register Data.

# LAYOUT

## POWER SUPPLIES

The DAC1220 requires the digital supply ( $DV_{DD}$ ) to be no greater than the analog supply ( $AV_{DD}$ ) +0.3V. In the majority of systems, this means that the analog supply must come up first, followed by the digital supply and  $V_{REF}$ . Failure to observe this condition could cause permanent damage to the DAC1220.

Inputs to the DAC1220, such as SDIO or  $V_{REF}$ , should not be present before the analog and digital supplies are on. Violating this condition could cause latch-up. If these signals are present before the supplies are on, series resistors should be used to limit the input current.

The best scheme is to power the analog section of the design and  $AV_{DD}$  of the DAC1220 from one +5V supply, and the digital section (and  $DV_{DD}$ ) from a separate +5V supply. The analog supply should come up first. This will ensure that SCLK, SDIO,  $\overline{CS}$  and  $V_{REF}$  do not exceed  $AV_{DD}$ , that the digital inputs are present only after  $AV_{DD}$  has been established, and that they do not exceed  $DV_{DD}$ .

The analog supply should be well regulated and low noise. For designs requiring very high resolution from the DAC1220, power supply rejection will be a concern. See the “PSRR vs Frequency” curve in the Typical Performance Curves section of this data sheet for more information.

The requirements for the digital supply are not as strict. However, high frequency noise on  $DV_{DD}$  can capacitively couple into the analog portion of the DAC1220. This noise can originate from switching power supplies, very fast microprocessors, or digital signal processors.

If one supply must be used to power the DAC1220, the  $AV_{DD}$  supply should be used to power  $DV_{DD}$ . This connection can be made via a 10 $\Omega$  resistor which, along with the decoupling capacitors, will provide some filtering between  $DV_{DD}$  and  $AV_{DD}$ . In some systems, a direct connection can be made. Experimentation may be the best way to determine the appropriate connection between  $AV_{DD}$  and  $DV_{DD}$ .

## GROUNDING

The analog and digital sections of the design should be carefully and cleanly partitioned. Each section should have its own ground plane with no overlap between them. AGND should be connected to the analog ground plane, as well as all other analog grounds. DGND should be connected to the digital ground plane, and all digital signals referenced to this plane.

The DAC1220 pinout is such that the converter is cleanly separated into an analog and digital portion. This should allow simple layout of the analog and digital sections of the design.

For a single converter system, AGND and DGND of the DAC1220 should be connected together, underneath the converter. Do not join the ground planes. Instead, connect the two with a moderate signal trace. For multiple converters, connect the two ground planes at one location, as central to all of the converters as possible. In some cases, experimentation may be required to find the best point to connect the two planes together. The printed circuit board can be designed to provide different analog/digital ground connections via short jumpers. The initial prototype can be used to establish which connection works best.

## DECOUPLING

Good decoupling practices should be used for the DAC1220 and for all components in the design. All decoupling capacitors, and specifically the 0.1 $\mu$ F ceramic capacitors, should be placed as close as possible to the pin being decoupled. A 1 $\mu$ F to 10 $\mu$ F capacitor, in parallel with a 0.1 $\mu$ F ceramic capacitor, should be used to decouple  $AV_{DD}$  to AGND. At a minimum, a 0.1 $\mu$ F ceramic capacitor should be used to decouple  $DV_{DD}$  to DGND, as well as for the digital supply on each digital component.