

# HIGH-SPEED CMOS LOGIC 16-CHANNEL ANALOG MULTIPLEXER and DEMULTIPLEXER

 Check for Samples: [CD74HCT4067-Q1](#)

## 1 FEATURES

- Qualified for Automotive Applications
- AEC-Q100 Test Guidance With the Following Results:
  - Device Temperature Grade 1: –40°C to 125°C Ambient Operating Temperature Range
  - Device HBM ESD Classification Level H1A
  - Device CDM ESD Classification Level C2
- Wide Analog Input Voltage Range
- Low ON Resistance
  - 70 Ω Typical ( $V_{CC} = 4.5\text{ V}$ )
- Fast Switching and Propagation Speeds
- Break-Before-Make Switching
  - 6 ns Typical ( $V_{CC} = 4.5\text{ V}$ )
- Fanout (Over Temperature Range)
  - Standard Outputs: 10 LSTTL Loads
  - Bus Driver Outputs: 15 LSTTL Loads
- Balanced Propagation Delay and Transition Times
- Significant Power Reduction Compared to LSTTL Logic ICs
- 4.5-V to 5.5-V Operation
- Direct LSTTL Input Logic Compatibility:  $V_{IL} = 0.8$

 $V_{Max}, V_{IH} = 2\text{ V Min}$ 

- CMOS Input Compatibility:  $I_I \leq 1\text{ }\mu\text{A}$  at  $V_{OL}, V_{OH}$

## 2 APPLICATIONS

- Automotive
- Analog Switch
- Analog Multiplexer and Demultiplexer

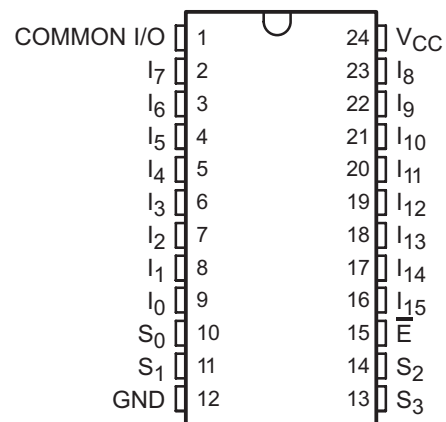
**M PACKAGE  
(TOP VIEW)**

## 3 DESCRIPTION

The CD74HCT4067-Q1 device is a digitally controlled analog switch that utilizes silicon-gate CMOS technology to achieve operating speeds similar to LSTTL, with the low power consumption of standard CMOS integrated circuits.

This analog multiplexer and demultiplexer controls analog voltages that may vary across the voltage supply range. It is a bidirectional switch, thus allowing any analog input to be used as an output and vice-versa. The switch has low (on) resistance and low (off) leakages. In addition, the device has an enable control that, when high, disables all switches to their off state.

### ORDERING INFORMATION<sup>(1)</sup>

$T_A$	PACKAGE <sup>(2)</sup>		ORDERABLE PART NUMBER <sup>(3)</sup>	TOP-SIDE MARKING
–40°C to 125°C	DW-SOIC-M	Reel of 2000	CD74HCT4067QM96Q1	HCT4067I

(1) For the most current package and ordering information, see the Package Option Addendum at the end of this document, or see the TI web site at [www.ti.com](http://www.ti.com).

(2) Package drawings, thermal data, and symbolization are available at [www.ti.com/packaging](http://www.ti.com/packaging).

(3) The suffix 96 denotes tape and reel.

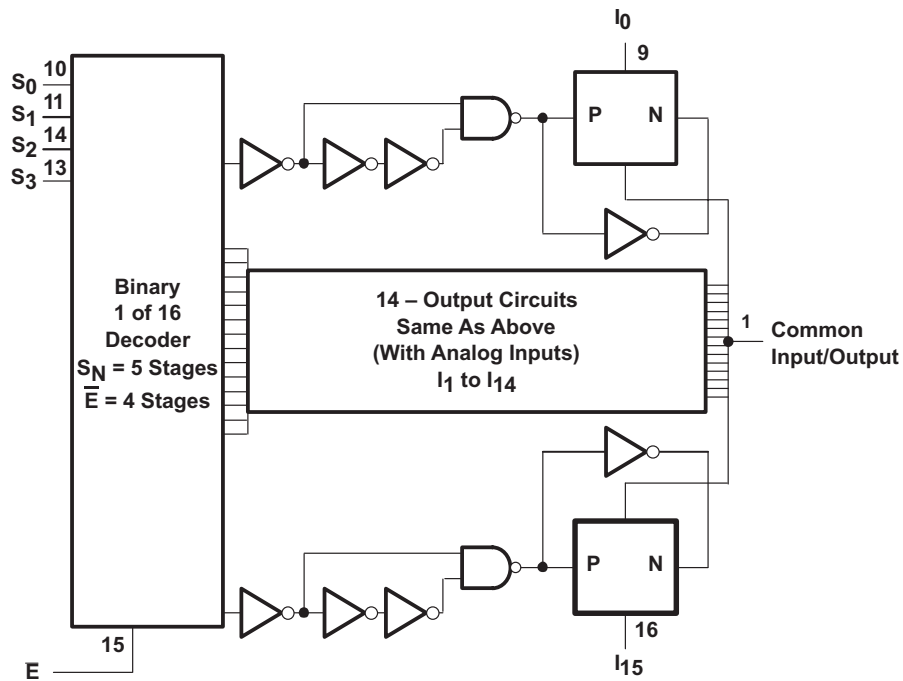

**Table 1. FUNCTION TABLE<sup>(1)</sup>**

S0	S1	S2	S3	$\bar{E}$	SELECTED CHANNEL
X	X	X	X	H	None
L	L	L	L	L	0
H	L	L	L	L	1
L	H	L	L	L	2
H	H	L	L	L	3
L	L	H	L	L	4
H	L	H	L	L	5
L	H	H	L	L	6
H	H	H	L	L	7
L	L	L	H	L	8
H	L	L	H	L	9
L	H	L	H	L	10
H	H	L	H	L	11
L	L	H	H	L	12
H	L	H	H	L	13
L	H	H	H	L	14
H	H	H	H	L	15

(1) H = High level  
 L = Low level  
 X = Don't care

**Logic Diagram (Positive Logic)**



### 3.1 ABSOLUTE MAXIMUM RATINGS<sup>(1)</sup>

over operating free-air temperature range (unless otherwise noted)

		VALUE		UNIT
		MIN	MAX	
V <sub>CC</sub>	Supply voltage range <sup>(2)</sup>	-0.5	7	V
I <sub>IK</sub>	Input clamp current (V <sub>I</sub> < -0.5 V or V <sub>I</sub> > V <sub>CC</sub> + 0.5 V)		±20	mA
I <sub>OK</sub>	Output clamp current (V <sub>O</sub> < -0.5 V or V <sub>O</sub> > V <sub>CC</sub> + 0.5 V)		±20	mA
I <sub>O</sub>	Switch current (V <sub>O</sub> > -0.5 V or V <sub>O</sub> < V <sub>CC</sub> + 0.5 V)		±25	mA
I <sub>O</sub>	Output source or sink current per output pin (V <sub>O</sub> > -0.5 V or V <sub>O</sub> < V <sub>CC</sub> + 0.5 V)		±25	mA
	Continuous current through V <sub>CC</sub> or GND		±50	mA
T <sub>J</sub>	Maximum junction temperature		150	°C
T <sub>stg</sub>	Storage temperature range	-65	150	°C
ESD Rating	Human Body Model (HBM) AEC-Q100 classification level H1A		400	V
	Charged Device Model (CDM) AEC-Q100 classification level C2		250	V
	Latch-up per JESD78D		Class 1	

- (1) Stresses beyond those listed under *Absolute Maximum Ratings* may cause permanent damage to the device. These are stress ratings only, and functional operation of the device at these or any other conditions beyond those indicated under *Recommended Operating Conditions* is not implied. Exposure to absolute-maximum-rated conditions for extended periods may affect device reliability.
- (2) All voltages are referenced to GND, unless otherwise specified.

### 3.2 THERMAL INFORMATION

THERMAL METRIC <sup>(1)</sup>		CD74HCT4067-Q1	UNIT
		DW (24 PINS)	
θ <sub>JA</sub>	Junction-to-ambient thermal resistance	62.3	°C/W
θ <sub>JCtop</sub>	Junction-to-case (top) thermal resistance	30.5	
θ <sub>JB</sub>	Junction-to-board thermal resistance	31.8	
ψ <sub>JT</sub>	Junction-to-top characterization parameter	7.7	
ψ <sub>JB</sub>	Junction-to-board characterization parameter	31.5	
θ <sub>JCbot</sub>	Junction-to-case (bottom) thermal resistance	N/A	

- (1) For more information about traditional and new thermal metrics, see the *Semiconductor and IC Package Thermal Metrics* application report (SPRA953).

### 3.3 RECOMMENDED OPERATING CONDITIONS<sup>(1)</sup>

over operating free-air temperature range (unless otherwise noted)

		MIN	MAX	UNIT
V <sub>CC</sub>	Supply voltage	4.5	5.5	V
V <sub>IH</sub>	High-level input voltage	2		V
V <sub>IL</sub>	Low-level input voltage		0.8	V
V <sub>I</sub>	Input voltage	0	V <sub>CC</sub>	V
V <sub>O</sub>	Output voltage	0	V <sub>CC</sub>	V
t <sub>t</sub>	Input transition (rise and fall) time	V <sub>CC</sub> = 4.5 V	500	ns
T <sub>A</sub>	Operating free-air temperature	-40	125	°C

- (1) All unused inputs of the device must be held at V<sub>CC</sub> or GND to ensure proper device operation. Refer to the TI application report, *Implications of Slow or Floating CMOS Inputs*, literature number SCBA004.

### 3.4 ELECTRICAL CHARACTERISTICS

over operating free-air temperature range (unless otherwise noted)

PARAMETER	TEST CONDITIONS	V <sub>I</sub>	V <sub>CC</sub>	T <sub>A</sub> = 25°C			T <sub>A</sub> = -40°C to 125°C		UNIT
				MIN	TYP	MAX	MIN	MAX	
I <sub>I</sub>	Logic input	V <sub>CC</sub> or GND	5.5 V			±0.1		±1	μA
I <sub>Iz</sub>	V <sub>IS</sub> = V <sub>CC</sub> or GND, $\bar{E}$ = V <sub>CC</sub>		5.5 V			±0.8		±8	μA
r <sub>on</sub>	I <sub>O</sub> = 1 mA	V <sub>IS</sub> = V <sub>CC</sub> or GND	V <sub>CC</sub> or GND	4.5 V	70	160		200	Ω
		V <sub>IS</sub> = V <sub>CC</sub> to GND	V <sub>CC</sub> to GND	4.5 V	90	180		225	
Δr <sub>on</sub>	Between any two switches		4.5 V		10				Ω
I <sub>CC</sub>		V <sub>CC</sub> or GND	5.5 V			8		80	μA
ΔI <sub>CC</sub>	Per input pin: 1 unit load <sup>(1)</sup>	V <sub>CC</sub> - 2.1 V	4.5 V to 5.5 V		100	360		450	μA
C <sub>I</sub>	Control inputs					10		10	pF

(1) For dual-supply systems, theoretical worst-case (V<sub>I</sub> = 2.4 V, V<sub>CC</sub> = 5.5 V) specification is 1.8 mA.

### 3.5 HCT INPUT LOADING

INPUT	UNIT LOADS <sup>(1)</sup>
S <sub>0</sub> - S <sub>3</sub>	0.5
$\bar{E}$	0.3

(1) Unit load is ΔI<sub>CC</sub> limit specified in the electrical characteristics table, for example, 360 μA max at 25°C.

### 3.6 SWITCHING CHARACTERISTICS

over operating free-air temperature range (unless otherwise noted) see [Figure 5](#)

PARAMETER	FROM (INPUT)	TO (OUTPUT)	LOAD CAPACITANCE	V <sub>CC</sub>	T <sub>A</sub> = 25°C			T <sub>A</sub> = -40°C TO 125°C		UNIT
					MIN	TYP	MAX	MIN	MAX	
t <sub>pd</sub>	I <sub>n</sub>	Common I/O	C <sub>L</sub> = 15 pF	5 V		6			ns	
			C <sub>L</sub> = 50 pF	4.5 V		15		19		
t <sub>en</sub>	$\bar{E}$	Common I/O	C <sub>L</sub> = 15 pF	5 V		25			ns	
			C <sub>L</sub> = 50 pF	4.5 V		60		75		
t <sub>en</sub>	S <sub>n</sub>	Common I/O	C <sub>L</sub> = 15 pF	5 V		25			ns	
			C <sub>L</sub> = 50 pF	4.5 V		60		75		
t <sub>dis</sub>	$\bar{E}$	Common I/O	C <sub>L</sub> = 15 pF	5 V		23			ns	
			C <sub>L</sub> = 50 pF	4.5 V		55		69		
t <sub>dis</sub>	S <sub>n</sub>	Common I/O	C <sub>L</sub> = 15 pF	5 V		21			ns	
			C <sub>L</sub> = 50 pF	4.5 V		58		73		

### 3.7 OPERATING CHARACTERISTICS

V<sub>CC</sub> = 5 V, T<sub>A</sub> = 25°C, input t<sub>r</sub>, t<sub>f</sub> = 6 ns

PARAMETER	TEST CONDITIONS	MIN	TYP	MAX	UNIT
C <sub>pd</sub>	Power dissipation capacitance <sup>(1)</sup>		96		pF

(1) C<sub>pd</sub> is used to determine the dynamic power consumption (P<sub>D</sub>), per package.

$$P_D = (C_{pd} \times V_{CC}^2 \times f_i) + \sum (C_L + C_S) \times V_{CC}^2 \times f_o$$

f<sub>O</sub> = output frequency

f<sub>I</sub> = input frequency

C<sub>L</sub> = output load capacitance

C<sub>S</sub> = switch capacitance

V<sub>CC</sub> = supply voltage

### 3.8 ANALOG CHANNEL CHARACTERISTICS

T<sub>A</sub> = 25°C

PARAMETER	TEST CONDITIONS	V <sub>CC</sub>	TYP	UNIT
f <sub>max</sub>	Switch frequency response bandwidth at -3 dB	4.5 V	89	MHz
	Sine-wave distortion	4.5 V	0.051	%
	Switch OFF signal feedthrough	4.5 V	-75	dB
C <sub>S</sub>	Switch input capacitance		5	pF
C <sub>COM</sub>	Common capacitance		50	pF

- (1) Adjust input voltage to obtain 0 dBm at output, f = 1 MHz.
- (2) V<sub>IS</sub> is centered at V<sub>CC</sub> / 2

### 4 PARAMETER MEASUREMENT INFORMATION

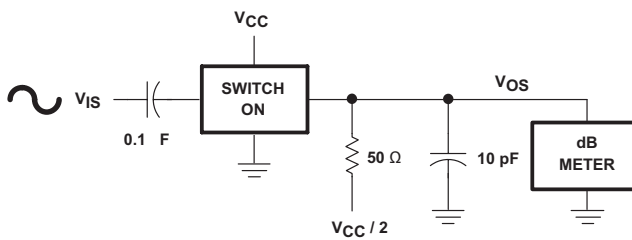

Figure 1. Frequency-Response Test Circuit

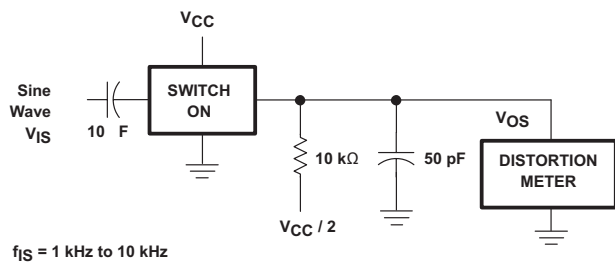

Figure 2. Sine-Wave Distortion Test Circuit

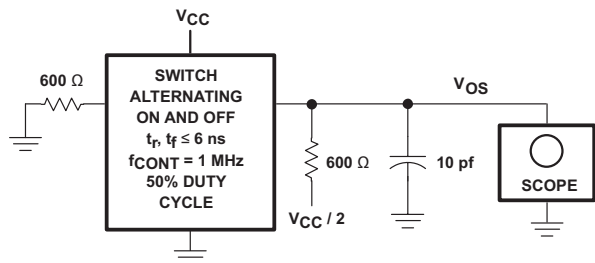

Figure 3. Control-to-Switch Feedthrough Noise Test Circuit

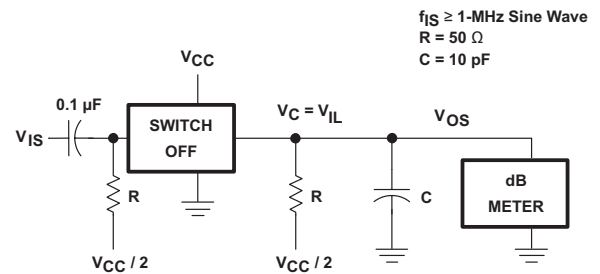
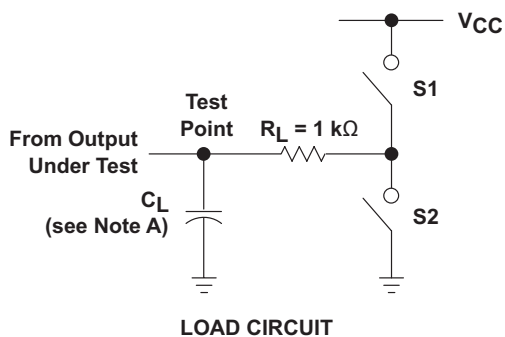
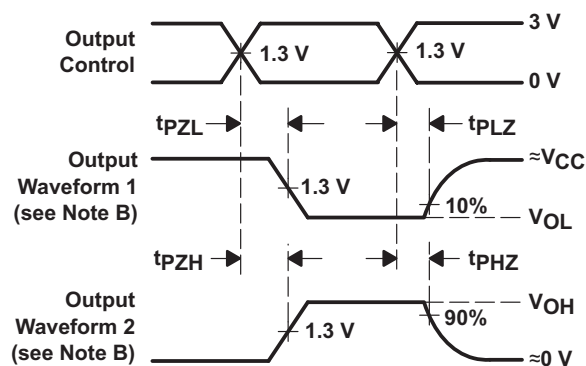
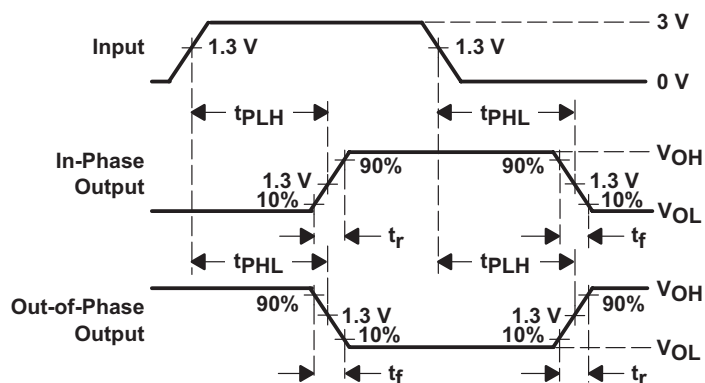

Figure 4. Switch OFF Signal Feedthrough Test Circuit

**PARAMETER MEASUREMENT INFORMATION (continued)**



PARAMETER	S1	S2	
$t_{en}$	tpZH	Open	Closed
	tpZL	Closed	Open
$t_{dis}$	tpHZ	Open	Closed
	tpLZ	Closed	Open
$t_{pd}$	Open	Open	



- NOTES:
- A.  $C_L$  includes probe and test-fixture capacitance.
  - B. Waveform 1 is for an output with internal conditions such that the output is low, except when disabled by the output control. Waveform 2 is for an output with internal conditions such that the output is high, except when disabled by the output control.
  - C. Phase relationships between waveforms were chosen arbitrarily. All input pulses are supplied by generators having the following characteristics:  $PRR \leq 1$  MHz,  $Z_O = 50 \Omega$ ,  $t_r = 6$  ns,  $t_f = 6$  ns.
  - D. For clock inputs,  $f_{max}$  is measured with the input duty cycle at 50%.
  - E. The outputs are measured one at a time, with one input transition per measurement.
  - F.  $t_{pLZ}$  and  $t_{pHZ}$  are the same as  $t_{dis}$ .
  - G.  $t_{pZL}$  and  $t_{pZH}$  are the same as  $t_{en}$ .
  - H.  $t_{pLH}$  and  $t_{pHL}$  are the same as  $t_{pd}$ .

**Figure 5. Load Circuit and Voltage Waveforms**

## 5 TYPICAL CHARACTERISTICS

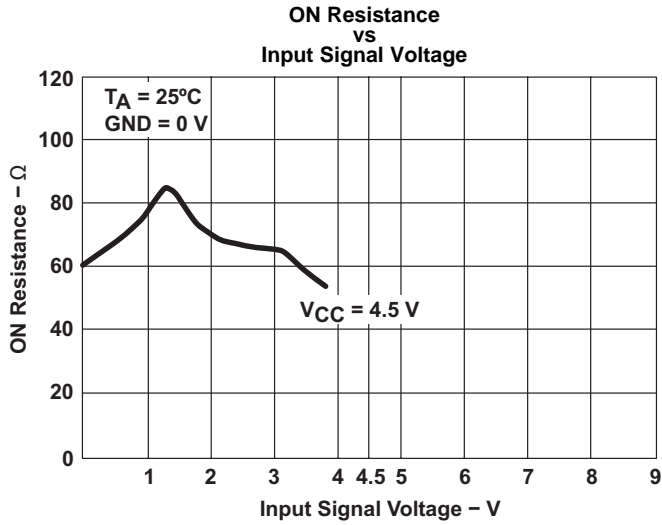

Figure 6.

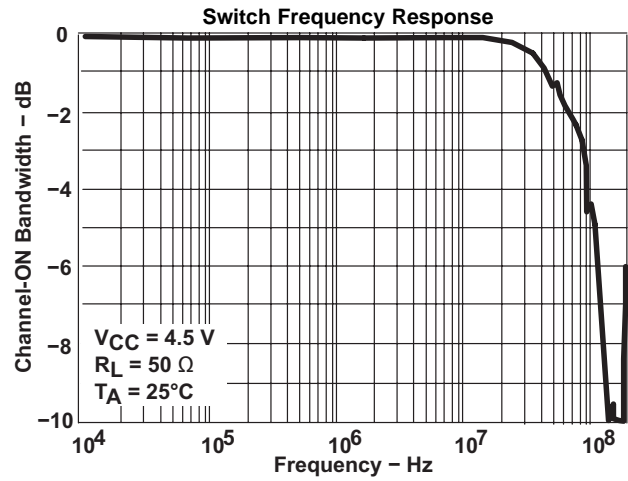

Figure 7.

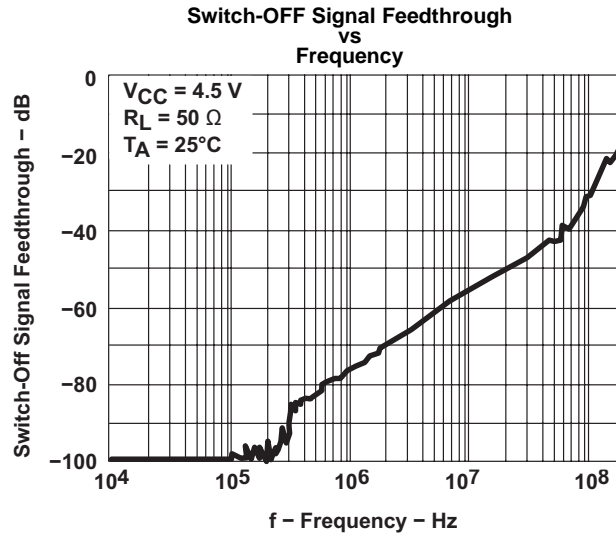

Figure 8.

## 6 REVISION HISTORY

NOTE: Page numbers for previous revisions may differ from page numbers in the current version.

<b>Changes from Revision A (April, 2008) to Revision B</b>	<b>Page</b>
• Changed H2 to H1A and C3B to C2 throughout document .....	1
• Added AEC-Q100 info to Features.....	1
• Removed from Features: Wide Operating Temperature Range: –40°C to 85°C .....	1
• Added applications .....	1
• Replaced SOIC-M package info in ordering info table with new row for DW-SOIC-M package .....	1
• Added ESD ratings to Abs Max table .....	3
• Added latch-up row in Abs Max table .....	3
• Changed max T <sub>A</sub> value from 85°C to 125°C .....	3
• Changed T <sub>A</sub> = –40°C to 85°C column to T <sub>A</sub> = –40°C to 125°C .....	4
• Changed T <sub>A</sub> = –40°C to 85°C column to T <sub>A</sub> = –40°C to 125°C .....	4



**PACKAGING INFORMATION**

Orderable Device	Status (1)	Package Type	Package Drawing	Pins	Package Qty	Eco Plan (2)	Lead/Ball Finish (6)	MSL Peak Temp (3)	Op Temp (°C)	Device Marking (4/5)	Samples
CD74HCT4067QM96Q1	ACTIVE	SOIC	DW	24	2000	Green (RoHS & no Sb/Br)	CU NIPDAU	Level-1-260C-UNLIM	-40 to 125	HCT4067I	<a href="#">Samples</a>
D24067IM96G4Q1	ACTIVE	SOIC	DW	24	2000	Green (RoHS & no Sb/Br)	CU NIPDAU	Level-1-260C-UNLIM	-40 to 85	HCT4067I	<a href="#">Samples</a>

(1) The marketing status values are defined as follows:

**ACTIVE:** Product device recommended for new designs.

**LIFEBUY:** TI has announced that the device will be discontinued, and a lifetime-buy period is in effect.

**NRND:** Not recommended for new designs. Device is in production to support existing customers, but TI does not recommend using this part in a new design.

**PREVIEW:** Device has been announced but is not in production. Samples may or may not be available.

**OBsolete:** TI has discontinued the production of the device.

(2) Eco Plan - The planned eco-friendly classification: Pb-Free (RoHS), Pb-Free (RoHS Exempt), or Green (RoHS & no Sb/Br) - please check <http://www.ti.com/productcontent> for the latest availability information and additional product content details.

**TBD:** The Pb-Free/Green conversion plan has not been defined.

**Pb-Free (RoHS):** TI's terms "Lead-Free" or "Pb-Free" mean semiconductor products that are compatible with the current RoHS requirements for all 6 substances, including the requirement that lead not exceed 0.1% by weight in homogeneous materials. Where designed to be soldered at high temperatures, TI Pb-Free products are suitable for use in specified lead-free processes.

**Pb-Free (RoHS Exempt):** This component has a RoHS exemption for either 1) lead-based flip-chip solder bumps used between the die and package, or 2) lead-based die adhesive used between the die and leadframe. The component is otherwise considered Pb-Free (RoHS compatible) as defined above.

**Green (RoHS & no Sb/Br):** TI defines "Green" to mean Pb-Free (RoHS compatible), and free of Bromine (Br) and Antimony (Sb) based flame retardants (Br or Sb do not exceed 0.1% by weight in homogeneous material)

(3) MSL, Peak Temp. - The Moisture Sensitivity Level rating according to the JEDEC industry standard classifications, and peak solder temperature.

(4) There may be additional marking, which relates to the logo, the lot trace code information, or the environmental category on the device.

(5) Multiple Device Markings will be inside parentheses. Only one Device Marking contained in parentheses and separated by a "~" will appear on a device. If a line is indented then it is a continuation of the previous line and the two combined represent the entire Device Marking for that device.

(6) Lead/Ball Finish - Orderable Devices may have multiple material finish options. Finish options are separated by a vertical ruled line. Lead/Ball Finish values may wrap to two lines if the finish value exceeds the maximum column width.

**Important Information and Disclaimer:** The information provided on this page represents TI's knowledge and belief as of the date that it is provided. TI bases its knowledge and belief on information provided by third parties, and makes no representation or warranty as to the accuracy of such information. Efforts are underway to better integrate information from third parties. TI has taken and continues to take reasonable steps to provide representative and accurate information but may not have conducted destructive testing or chemical analysis on incoming materials and chemicals. TI and TI suppliers consider certain information to be proprietary, and thus CAS numbers and other limited information may not be available for release.

In no event shall TI's liability arising out of such information exceed the total purchase price of the TI part(s) at issue in this document sold by TI to Customer on an annual basis.

**OTHER QUALIFIED VERSIONS OF CD74HCT4067-Q1 :**

- Catalog: [CD74HCT4067](#)

**NOTE: Qualified Version Definitions:**

- Catalog - TI's standard catalog product

**TAPE AND REEL INFORMATION**

**QUADRANT ASSIGNMENTS FOR PIN 1 ORIENTATION IN TAPE**

\*All dimensions are nominal

Device	Package Type	Package Drawing	Pins	SPQ	Reel Diameter (mm)	Reel Width W1 (mm)	A0 (mm)	B0 (mm)	K0 (mm)	P1 (mm)	W (mm)	Pin1 Quadrant
CD74HCT4067QM96Q1	SOIC	DW	24	2000	330.0	24.4	10.75	15.7	2.7	12.0	24.0	Q1

TAPE AND REEL BOX DIMENSIONS



\*All dimensions are nominal

Device	Package Type	Package Drawing	Pins	SPQ	Length (mm)	Width (mm)	Height (mm)
CD74HCT4067QM96Q1	SOIC	DW	24	2000	367.0	367.0	45.0

DW (R-PDSO-G24)

PLASTIC SMALL OUTLINE

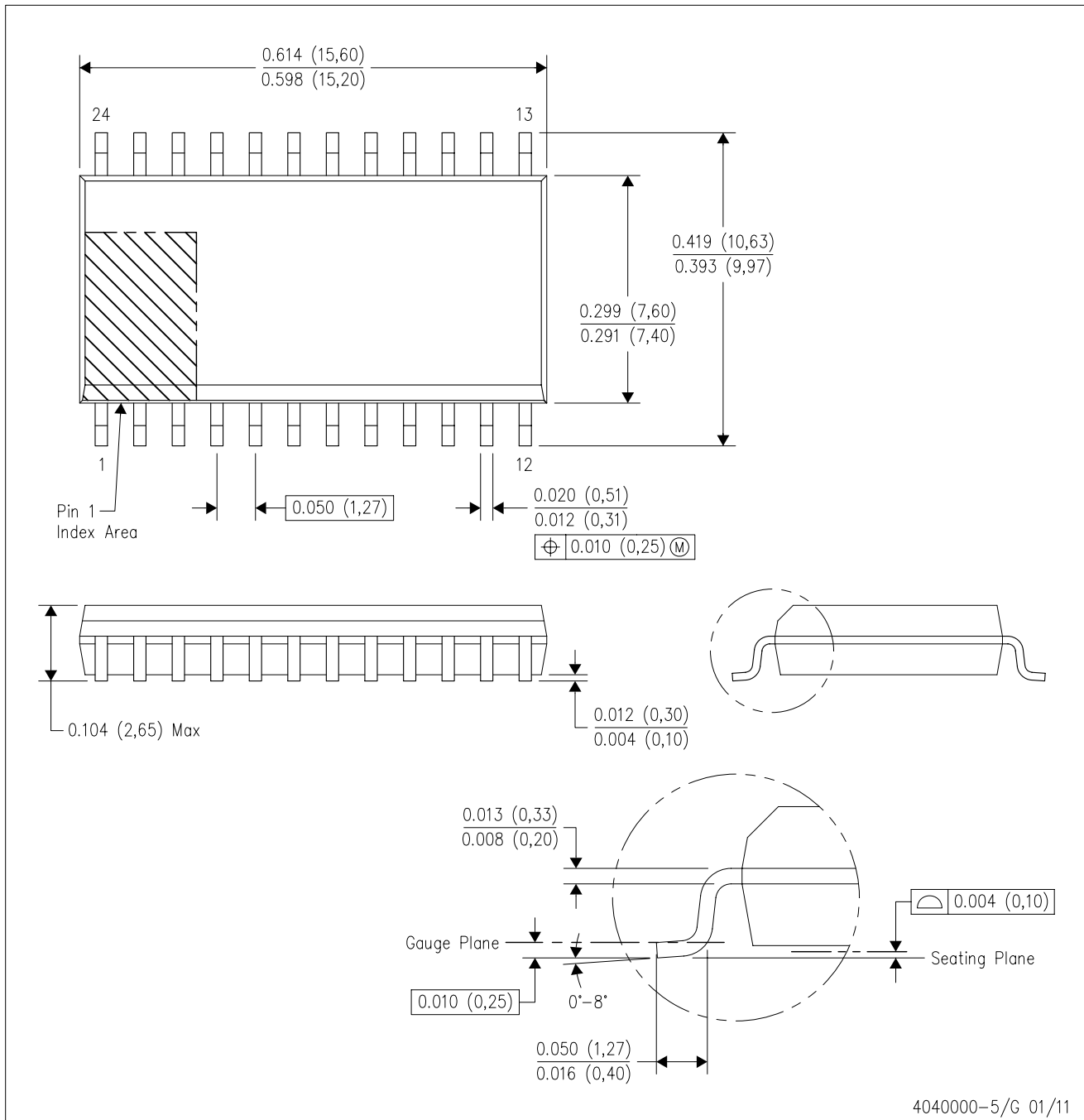

- NOTES:
- A. All linear dimensions are in inches (millimeters). Dimensioning and tolerancing per ASME Y14.5M-1994.
  - B. This drawing is subject to change without notice.
  - C. Body dimensions do not include mold flash or protrusion not to exceed 0.006 (0,15).
  - D. Falls within JEDEC MS-013 variation AD.

## IMPORTANT NOTICE

Texas Instruments Incorporated and its subsidiaries (TI) reserve the right to make corrections, enhancements, improvements and other changes to its semiconductor products and services per JESD46, latest issue, and to discontinue any product or service per JESD48, latest issue. Buyers should obtain the latest relevant information before placing orders and should verify that such information is current and complete. All semiconductor products (also referred to herein as "components") are sold subject to TI's terms and conditions of sale supplied at the time of order acknowledgment.

TI warrants performance of its components to the specifications applicable at the time of sale, in accordance with the warranty in TI's terms and conditions of sale of semiconductor products. Testing and other quality control techniques are used to the extent TI deems necessary to support this warranty. Except where mandated by applicable law, testing of all parameters of each component is not necessarily performed.

TI assumes no liability for applications assistance or the design of Buyers' products. Buyers are responsible for their products and applications using TI components. To minimize the risks associated with Buyers' products and applications, Buyers should provide adequate design and operating safeguards.

TI does not warrant or represent that any license, either express or implied, is granted under any patent right, copyright, mask work right, or other intellectual property right relating to any combination, machine, or process in which TI components or services are used. Information published by TI regarding third-party products or services does not constitute a license to use such products or services or a warranty or endorsement thereof. Use of such information may require a license from a third party under the patents or other intellectual property of the third party, or a license from TI under the patents or other intellectual property of TI.

Reproduction of significant portions of TI information in TI data books or data sheets is permissible only if reproduction is without alteration and is accompanied by all associated warranties, conditions, limitations, and notices. TI is not responsible or liable for such altered documentation. Information of third parties may be subject to additional restrictions.

Resale of TI components or services with statements different from or beyond the parameters stated by TI for that component or service voids all express and any implied warranties for the associated TI component or service and is an unfair and deceptive business practice. TI is not responsible or liable for any such statements.

Buyer acknowledges and agrees that it is solely responsible for compliance with all legal, regulatory and safety-related requirements concerning its products, and any use of TI components in its applications, notwithstanding any applications-related information or support that may be provided by TI. Buyer represents and agrees that it has all the necessary expertise to create and implement safeguards which anticipate dangerous consequences of failures, monitor failures and their consequences, lessen the likelihood of failures that might cause harm and take appropriate remedial actions. Buyer will fully indemnify TI and its representatives against any damages arising out of the use of any TI components in safety-critical applications.

In some cases, TI components may be promoted specifically to facilitate safety-related applications. With such components, TI's goal is to help enable customers to design and create their own end-product solutions that meet applicable functional safety standards and requirements. Nonetheless, such components are subject to these terms.

No TI components are authorized for use in FDA Class III (or similar life-critical medical equipment) unless authorized officers of the parties have executed a special agreement specifically governing such use.

Only those TI components which TI has specifically designated as military grade or "enhanced plastic" are designed and intended for use in military/aerospace applications or environments. Buyer acknowledges and agrees that any military or aerospace use of TI components which have **not** been so designated is solely at the Buyer's risk, and that Buyer is solely responsible for compliance with all legal and regulatory requirements in connection with such use.

TI has specifically designated certain components as meeting ISO/TS16949 requirements, mainly for automotive use. In any case of use of non-designated products, TI will not be responsible for any failure to meet ISO/TS16949.

### Products

Audio	<a href="http://www.ti.com/audio">www.ti.com/audio</a>
Amplifiers	<a href="http://amplifier.ti.com">amplifier.ti.com</a>
Data Converters	<a href="http://dataconverter.ti.com">dataconverter.ti.com</a>
DLP® Products	<a href="http://www.dlp.com">www.dlp.com</a>
DSP	<a href="http://dsp.ti.com">dsp.ti.com</a>
Clocks and Timers	<a href="http://www.ti.com/clocks">www.ti.com/clocks</a>
Interface	<a href="http://interface.ti.com">interface.ti.com</a>
Logic	<a href="http://logic.ti.com">logic.ti.com</a>
Power Mgmt	<a href="http://power.ti.com">power.ti.com</a>
Microcontrollers	<a href="http://microcontroller.ti.com">microcontroller.ti.com</a>
RFID	<a href="http://www.ti-rfid.com">www.ti-rfid.com</a>
OMAP Applications Processors	<a href="http://www.ti.com/omap">www.ti.com/omap</a>
Wireless Connectivity	<a href="http://www.ti.com/wirelessconnectivity">www.ti.com/wirelessconnectivity</a>

### Applications

Automotive and Transportation	<a href="http://www.ti.com/automotive">www.ti.com/automotive</a>
Communications and Telecom	<a href="http://www.ti.com/communications">www.ti.com/communications</a>
Computers and Peripherals	<a href="http://www.ti.com/computers">www.ti.com/computers</a>
Consumer Electronics	<a href="http://www.ti.com/consumer-apps">www.ti.com/consumer-apps</a>
Energy and Lighting	<a href="http://www.ti.com/energy">www.ti.com/energy</a>
Industrial	<a href="http://www.ti.com/industrial">www.ti.com/industrial</a>
Medical	<a href="http://www.ti.com/medical">www.ti.com/medical</a>
Security	<a href="http://www.ti.com/security">www.ti.com/security</a>
Space, Avionics and Defense	<a href="http://www.ti.com/space-avionics-defense">www.ti.com/space-avionics-defense</a>
Video and Imaging	<a href="http://www.ti.com/video">www.ti.com/video</a>

### TI E2E Community

[e2e.ti.com](http://e2e.ti.com)