

Features

- High Speed
 - $t_{AA} = 12 \text{ ns}$
- Low Active Power
 - $I_{CC} = 250 \text{ mA}$ at 12 ns
- Low CMOS Standby Power
 - $I_{SB2} = 50 \text{ mA}$
- Operating Voltages of $3.3 \pm 0.3 \text{ V}$
- 2.0 V Data Retention
- Automatic Power Down when Deselected
- TTL Compatible Inputs and Outputs
- Available in Pb-free 48-ball FBGA Package

Functional Description

The CY7C1079DV33 is a high performance CMOS Static RAM organized as 4,194,304 words by 8 bits.

To write to the device, take Chip Enable ($\overline{CE}^{[1]}$) and Write Enable (\overline{WE}) input LOW. Data on the eight I/O pins (I/O_0 through I/O_7) is then written into the location specified on the address pins (A_0 through A_{21}).

To read from the device, take Chip Enable ($\overline{CE}^{[1]}$) LOW and Output Enable (\overline{OE}) LOW while forcing the Write Enable (\overline{WE}) HIGH. Under these conditions, the contents of the memory location specified by the address pins appear on the I/O pins. See Truth Table (Single Chip Enable) on page 9 for a complete description of Read and Write modes.

The input and output pins (I/O_0 through I/O_7) are placed in a high impedance state when the device is deselected ($\overline{CE}^{[1]}$ HIGH), the outputs are disabled (\overline{OE} HIGH), or during a write operation ($\overline{CE}^{[1]}$ LOW and \overline{WE} LOW).

The CY7C1079DV33 is available in a 48-ball FBGA package.

Logic Block Diagram

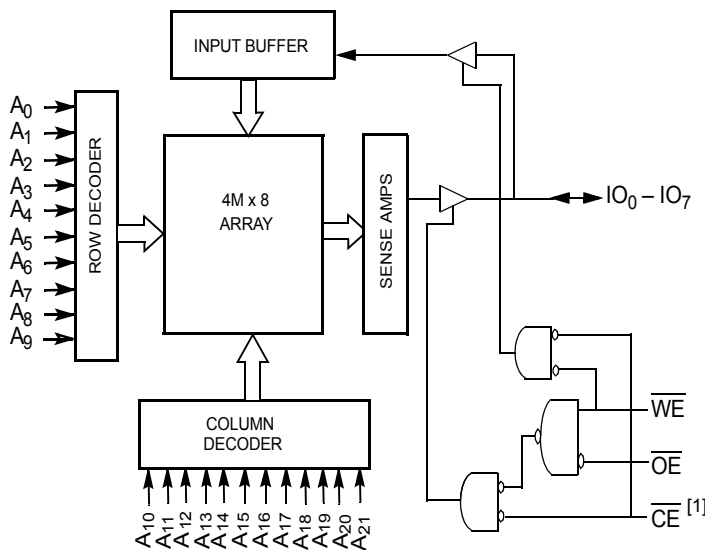

Note

1. BGA packaged device is offered in single CE and dual CE options. In this data sheet, for a dual CE device, \overline{CE} refers to the internal logical combination of \overline{CE}_1 and \overline{CE}_2 such that when \overline{CE}_1 is LOW and \overline{CE}_2 is HIGH, \overline{CE} is LOW. For all other cases \overline{CE} is HIGH.

Contents

Selection Guide	3	Ordering Information	10
Pin Configuration	3	Ordering Code Definitions	10
Maximum Ratings	4	Package Diagrams	11
Operating Range	4	Acronyms	12
DC Electrical Characteristics	4	Document Conventions	12
Capacitance	5	Units of Measure	12
Thermal Resistance	5	Document History Page	13
Data Retention Characteristics	5	Sales, Solutions, and Legal Information	14
AC Switching Characteristics	6	Worldwide Sales and Design Support	14
Switching Waveforms	7	Products	14
Truth Table (Single Chip Enable)	9	PSoC Solutions	14
Truth Table (Dual Chip Enable)	9		

Selection Guide

Description	-12	Unit
Maximum Access Time	12	ns
Maximum Operating Current	250	mA
Maximum CMOS Standby Current	50	mA

Pin Configuration

Figure 1. 48-ball FBGA (Single Chip Enable) [2]

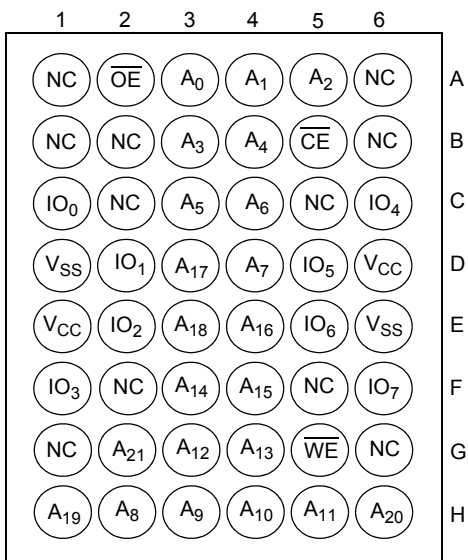
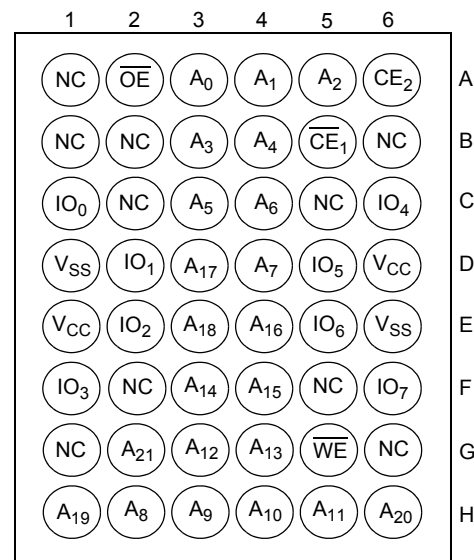

Figure 2. 48-ball FBGA (Dual Chip Enable) [2]



Note

2. NC pins are not connected to the die.

Maximum Ratings

Exceeding maximum ratings may shorten the useful life of the device. These user guidelines are not tested.

Storage Temperature	-65 °C to +150 °C
Ambient Temperature with Power Applied	-55 °C to +125 °C
Supply Voltage on V _{CC} Relative to GND ^[3]	-0.5 V to +4.6 V
DC Voltage Applied to Outputs in High Z State ^[3]	-0.5 V to V _{CC} + 0.5 V
DC Input Voltage ^[3]	-0.5 V to V _{CC} + 0.5 V

Current into Outputs (LOW).....	20 mA
Static Discharge Voltage.....	> 2001 V (MIL-STD-883, Method 3015)
Latch Up Current	> 200 mA

Operating Range

Range	Ambient Temperature	V _{CC}
Industrial	-40 °C to +85 °C	3.3 V ± 0.3 V

DC Electrical Characteristics

Over the Operating Range

Parameter	Description	Test Conditions	-12		Unit
			Min	Max	
V _{OH}	Output HIGH Voltage	V _{CC} = Min, I _{OH} = -4.0 mA	2.4	-	V
V _{OL}	Output LOW Voltage	V _{CC} = Min, I _{OL} = 8.0 mA	-	0.4	V
V _{IH}	Input HIGH Voltage		2.0	V _{CC} + 0.3	V
V _{IL}	Input LOW Voltage ^[3]		-0.3	0.8	V
I _{IX}	Input Leakage Current	GND ≤ V _I ≤ V _{CC}	-1	+1	μA
I _{OZ}	Output Leakage Current	GND ≤ V _{OUT} ≤ V _{CC} , Output disabled	-1	+1	μA
I _{CC}	V _{CC} Operating Supply Current	V _{CC} = Max, f = f _{MAX} = 1/t _{RC} , I _{OUT} = 0 mA CMOS levels	-	250	mA
I _{SB1}	Automatic CE Power Down Current — TTL Inputs	Max V _{CC} , $\overline{CE}^{[4]} \geq V_{IH}$, V _{IN} ≥ V _{IH} or V _{IN} ≤ V _{IL} , f = f _{MAX}	-	60	mA
I _{SB2}	Automatic CE Power Down Current — CMOS Inputs	Max V _{CC} , $\overline{CE}^{[4]} \geq V_{CC} - 0.3 V$, V _{IN} ≥ V _{CC} - 0.3 V, or V _{IN} ≤ 0.3 V, f = 0	-	50	mA

Notes

- V_{IL} (min) = -2.0 V and V_{IH} (max) = V_{CC} + 2 V for pulse durations of less than 20 ns.
- BGA packaged device is offered in single CE and dual CE options. In this data sheet, for a dual CE device, \overline{CE} refers to the internal logical combination of \overline{CE}_1 and CE₂ such that when CE₁ is LOW and CE₂ is HIGH, \overline{CE} is LOW. For all other cases \overline{CE} is HIGH.

Capacitance

Tested initially and after any design or process changes that may affect these parameters.

Parameter	Description	Test Conditions	48-ball FBGA	Unit
C_{IN}	Input Capacitance	$T_A = 25\text{ }^\circ\text{C}$, $f = 1\text{ MHz}$, $V_{CC} = 3.3\text{ V}$	16	pF
C_{OUT}	I/O Capacitance		20	pF

Thermal Resistance

Tested initially and after any design or process changes that may affect these parameters.

Parameter	Description	Test Conditions	48-ball FBGA	Unit
Θ_{JA}	Thermal Resistance (Junction to Ambient)	Still air, soldered on a 3 × 4.5 inch, four layer printed circuit board	30.91	$^\circ\text{C/W}$
Θ_{JC}	Thermal Resistance (Junction to Case)		13.60	$^\circ\text{C/W}$

Figure 3. AC Test Loads and Waveforms^[5]

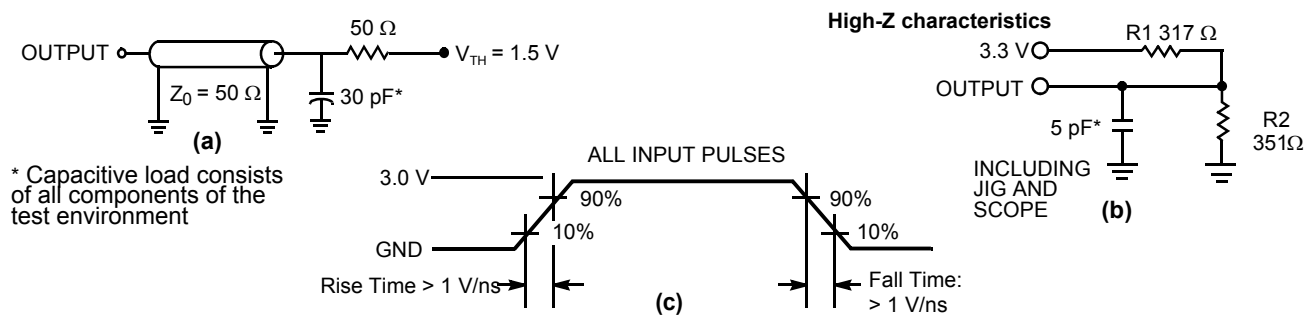

Data Retention Characteristics

Over the Operating Range

Parameter	Description	Conditions	Min	Typ	Max	Unit
V_{DR}	V_{CC} for Data Retention		2	–	–	V
I_{CCDR}	Data Retention Current	$V_{CC} = 2\text{ V}$, $\overline{CE}^{[6]} \geq V_{CC} - 0.2\text{ V}$, $V_{IN} \geq V_{CC} - 0.2\text{ V}$ or $V_{IN} \leq 0.2\text{ V}$	–	–	50	mA
$t_{CDR}^{[7]}$	Chip Deselect to Data Retention Time		0	–	–	ns
$t_R^{[8]}$	Operation Recovery Time		t_{RC}	–	–	ns

Figure 4. Data Retention Waveform

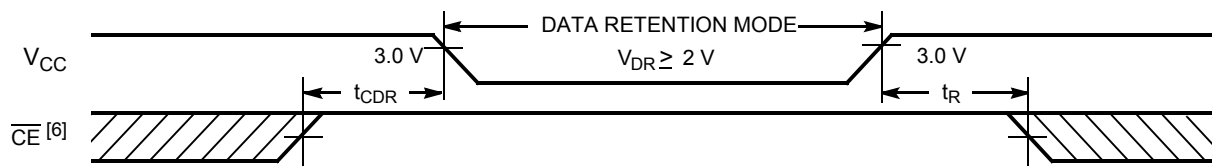

Notes

- Valid SRAM operation does not occur until the power supplies have reached the minimum operating V_{DD} (3.0 V). 100 μs (t_{power}) after reaching the minimum operating V_{DD} , normal SRAM operation begins including reduction in V_{DD} to the data retention (V_{CCDR} , 2.0 V) voltage.
- BGA packaged device is offered in single CE and dual CE options. In this data sheet, for a dual CE device, \overline{CE} refers to the internal logical combination of \overline{CE}_1 and \overline{CE}_2 such that when \overline{CE}_1 is LOW and \overline{CE}_2 is HIGH, \overline{CE} is LOW. For all other cases \overline{CE} is HIGH.
- Tested initially and after any design or process changes that may affect these parameters.
- Full device operation requires linear V_{CC} ramp from V_{DR} to $V_{CC(min.)} \geq 50\text{ }\mu\text{s}$ or stable at $V_{CC(min.)} \geq 50\text{ }\mu\text{s}$.

AC Switching Characteristics

Over the Operating Range ^[9]

Parameter	Description	-12		Unit
		Min	Max	
Read Cycle				
t_{power}	V_{CC} (Typical) to the First Access ^[10]	100	–	μ s
t_{RC}	Read Cycle Time	12	–	ns
t_{AA}	Address to Data Valid	–	12	ns
t_{OHA}	Data Hold from Address Change	3	–	ns
t_{ACE}	\overline{CE} ^[11] LOW to Data Valid	–	12	ns
t_{DOE}	\overline{OE} LOW to Data Valid	–	7	ns
t_{LZOE}	\overline{OE} LOW to Low Z	1	–	ns
t_{HZOE}	\overline{OE} HIGH to High Z ^[12]	–	7	ns
t_{LZCE}	\overline{CE} LOW to Low Z ^[11, 12]	3	–	ns
t_{HZCE}	\overline{CE} HIGH LOW to High Z ^[11, 12]	–	7	ns
t_{PU}	\overline{CE} LOW HIGH to Power Up ^[11, 13]	0	–	ns
t_{PD}	\overline{CE} HIGH LOW to Power Down ^[11, 13]	–	12	ns
Write Cycle ^[14, 15]				
t_{WC}	Write Cycle Time	12	–	ns
t_{SCE}	\overline{CE} ^[11] LOW HIGH to Write End	9	–	ns
t_{AW}	Address Setup to Write End	9	–	ns
t_{HA}	Address Hold from Write End	0	–	ns
t_{SA}	Address Setup to Write Start	0	–	ns
t_{PWE}	\overline{WE} Pulse Width	9	–	ns
t_{SD}	Data Setup to Write End	7	–	ns
t_{HD}	Data Hold from Write End	0	–	ns
t_{LZWE}	\overline{WE} HIGH to Low Z ^[12]	3	–	ns
t_{HZWE}	\overline{WE} LOW to High Z ^[12]	–	7	ns

Notes

9. Test conditions assume signal transition time of 3 ns or less, timing reference levels of 1.5 V, and input pulse levels of 0 to 3.0 V. Test conditions for the read cycle use output loading shown in part a) of Figure 3 on page 5, unless specified otherwise.
10. t_{POWER} gives the minimum amount of time that the power supply is at typical V_{CC} values until the first memory access is performed.
11. BGA packaged device is offered in single CE and dual CE options. In this data sheet, for a dual CE device, \overline{CE} refers to the internal logical combination of \overline{CE}_1 and \overline{CE}_2 such that when \overline{CE}_1 is LOW and \overline{CE}_2 is HIGH, \overline{CE} is LOW. For all other cases \overline{CE} is HIGH.
12. t_{HZOE} , t_{HZCE} , t_{HZWE} , t_{LZOE} , t_{LZCE} , and t_{LZWE} are specified with a load capacitance of 5 pF as in (b) of Figure 3 on page 5. Transition is measured ± 200 mV from steady state voltage.
13. These parameters are guaranteed by design and are not tested.
14. The internal write time of the memory is defined by the overlap of \overline{WE} , $\overline{CE} = V_{IL}$. \overline{CE} and \overline{WE} are LOW to initiate a write, and the transition of any of these signals can terminate. The input data setup and hold timing should be referenced to the edge of the signal that terminates the write.
15. The minimum write cycle time for Write Cycle No. 2 (\overline{WE} controlled, \overline{OE} LOW) is the sum of t_{HZWE} and t_{SD} .

Switching Waveforms

Figure 5. Read Cycle No. 1 [16, 17]

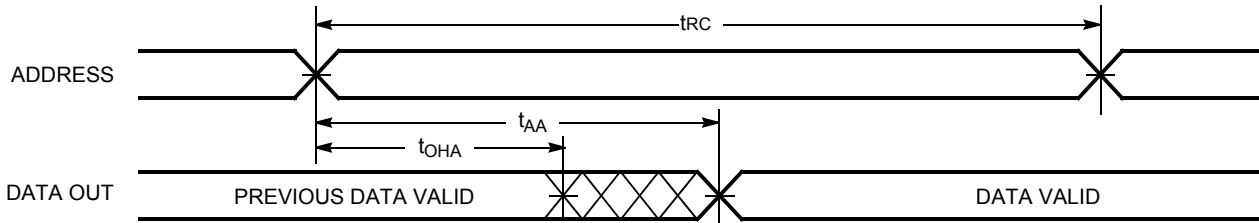
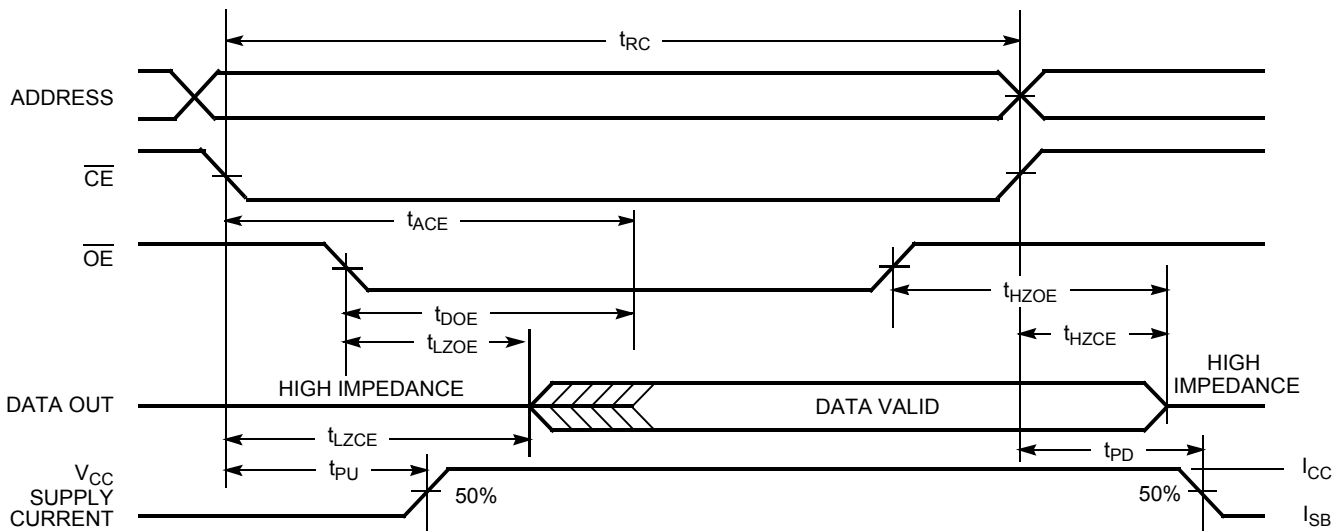

Figure 6. Read Cycle No. 2 (\overline{OE} Controlled) [17, 18, 19]



Notes

- 16. The device is continuously selected. $\overline{CE} = V_{IL}$.
- 17. \overline{WE} is HIGH for read cycle.
- 18. BGA packaged device is offered in single CE and dual CE options. In this data sheet, for a dual CE device, \overline{CE} refers to the internal logical combination of \overline{CE}_1 and \overline{CE}_2 such that when \overline{CE}_1 is LOW and \overline{CE}_2 is HIGH, CE is LOW. For all other cases CE is HIGH.
- 19. Address valid before or similar to CE transition LOW.

Switching Waveforms (continued)

Figure 7. Write Cycle No. 1 ($\overline{\text{CE}}$ Controlled) [20, 21, 22]

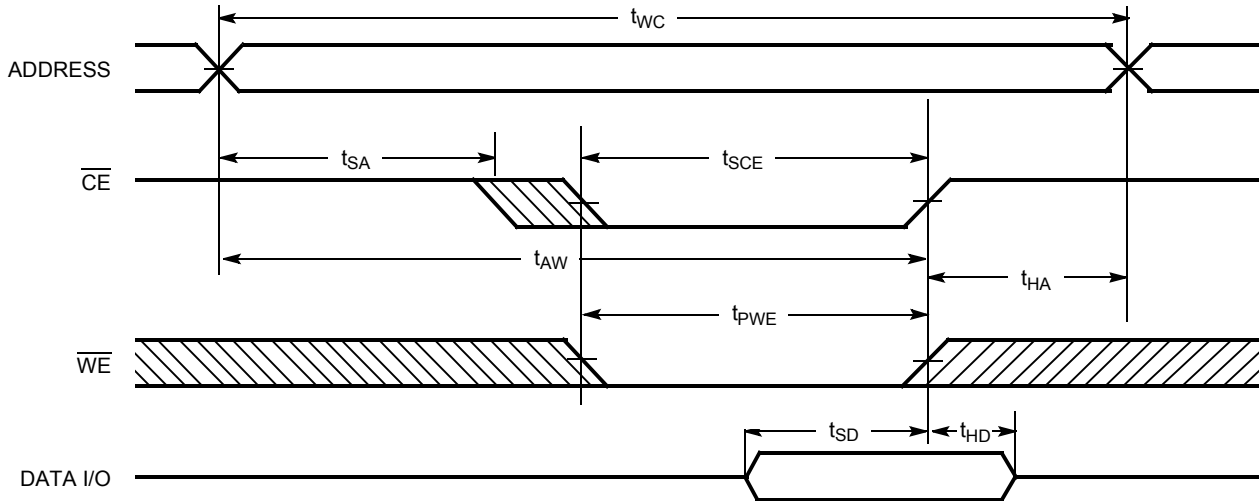
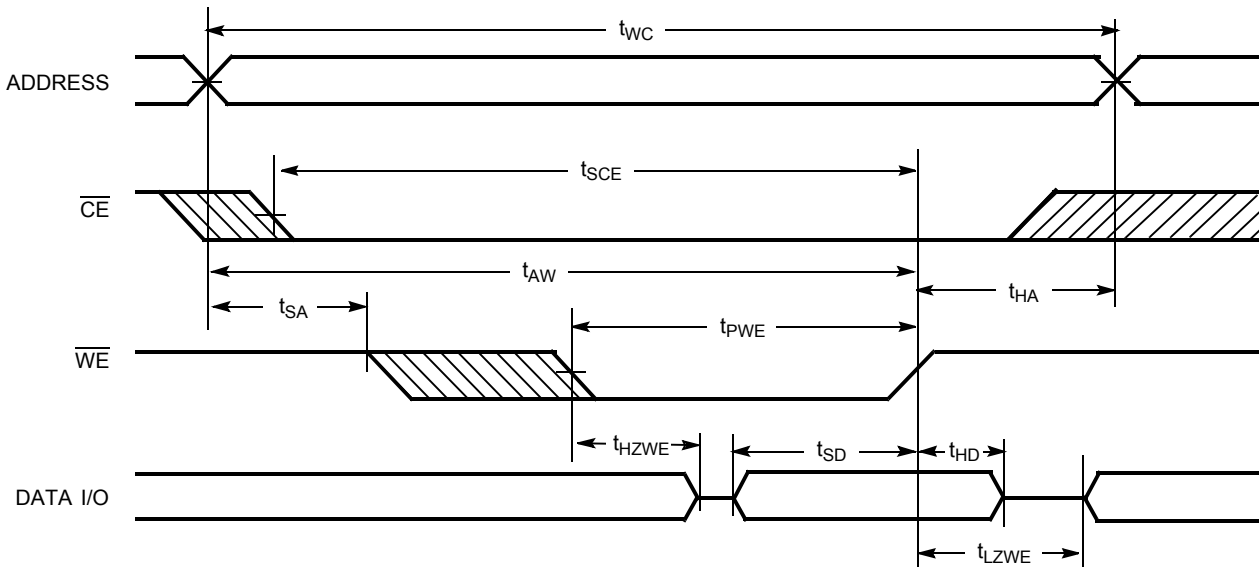

Figure 8. Write Cycle No. 2 ($\overline{\text{WE}}$ Controlled, $\overline{\text{OE}}$ LOW) [20, 21, 22]



Notes

20. BGA packaged device is offered in single CE and dual CE options. In this data sheet, for a dual CE device, $\overline{\text{CE}}$ refers to the internal logical combination of $\overline{\text{CE}}_1$ and $\overline{\text{CE}}_2$ such that when $\overline{\text{CE}}_1$ is LOW and $\overline{\text{CE}}_2$ is HIGH, $\overline{\text{CE}}$ is LOW. For all other cases $\overline{\text{CE}}$ is HIGH.

21. Data I/O is high impedance if $\overline{\text{OE}} = V_{IH}$.

22. If $\overline{\text{CE}}$ goes HIGH simultaneously with $\overline{\text{WE}}$ going HIGH, the output remains in a high impedance state.

Truth Table (Single Chip Enable)

$\overline{CE}^{[1]}$	\overline{OE}	\overline{WE}	I/O ₀ –I/O ₇	Mode	Power
H	X	X	High Z	Power Down	Standby (I _{SB})
L	L	H	Data Out	Read All Bits	Active (I _{CC})
L	X	L	Data In	Write All Bits	Active (I _{CC})
L	H	H	High Z	Selected, Outputs Disabled	Active (I _{CC})

Truth Table (Dual Chip Enable)

\overline{CE}_1	\overline{CE}_2	\overline{OE}	\overline{WE}	I/O ₀ –I/O ₇	Mode	Power
H	X	X	X	High Z	Power Down	Standby (I _{SB})
X	L	X	X	High Z	Power Down	Standby (I _{SB})
L	H	L	H	Data Out	Read All Bits	Active (I _{CC})
L	H	X	L	Data In	Write All Bits	Active (I _{CC})
L	H	H	H	High Z	Selected, Outputs Disabled	Active (I _{CC})

Ordering Information

Speed (ns)	Ordering Code	Package Diagram	Package Type	Operating Range
12	CY7C1079DV33-12BAXI	51-85191	48-ball FBGA (8 × 9.5 × 1.2 mm) (Pb-free) ^[23]	Industrial
12	CY7C1079DV33-12B2XI	51-85191	48-ball FBGA (8 × 9.5 × 1.2 mm) (Pb-free) ^[24]	Industrial

Contact sales for part availability.

Ordering Code Definitions

CY 7 C 1 07 9 D V33 - 12 XXX I

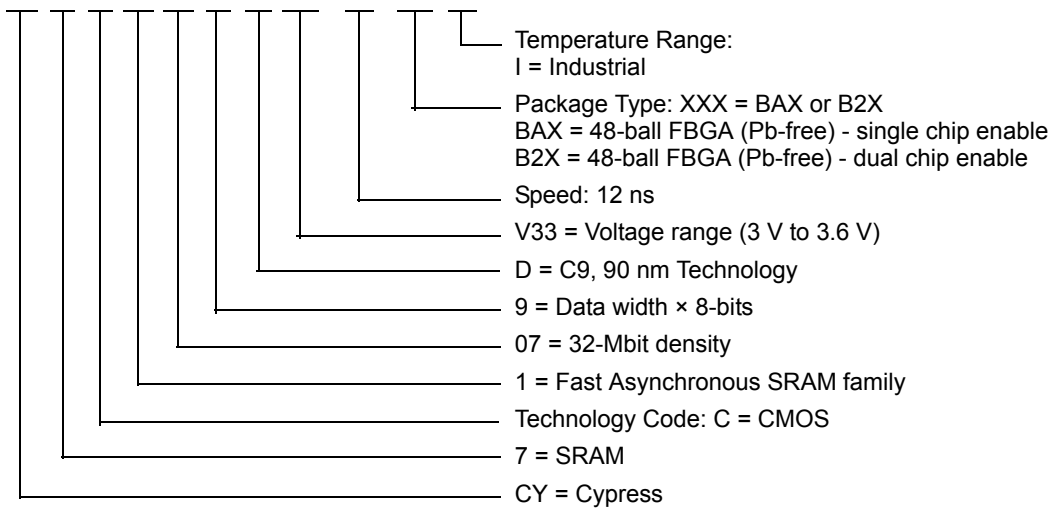

Notes

23. This BGA package is offered with single chip enable.
24. This BGA package is offered with dual chip enable.

Package Diagrams

Figure 9. 48-ball FBGA (8 × 9.5 × 1.2 mm), 51-85191

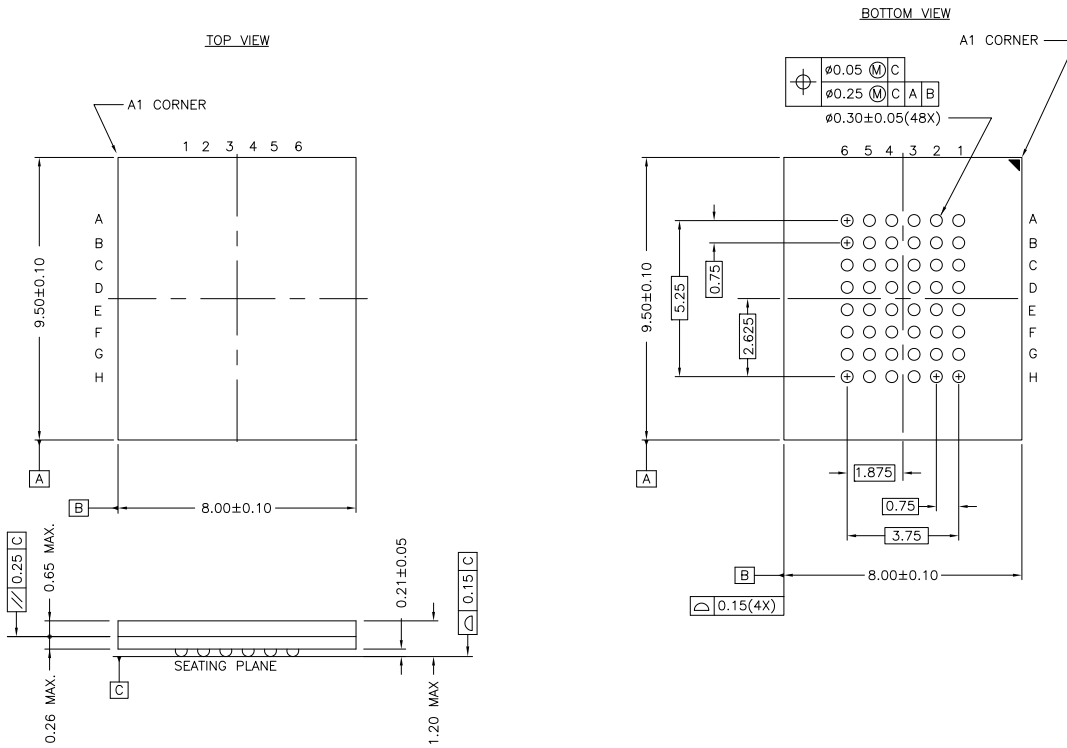

51-85191 *A

Acronyms

Acronym	Description
\overline{CE}	chip enable
CMOS	complementary metal oxide semiconductor
FPBGA	fine-pitch ball grid array
I/O	input/output
\overline{OE}	output enable
SRAM	static random access memory
TTL	transistor transistor logic
\overline{WE}	write enable

Document Conventions

Units of Measure

Symbol	Unit of Measure
ns	nano seconds
V	Volts
μA	micro Amperes
μs	micro seconds
mV	milli Volts
mA	milli Amperes
ms	milli seconds
mm	milli meter
MHz	Mega Hertz
pF	pico Farad
W	Watts
%	percent
Ω	ohms
$^{\circ}C$	degree Celcius

Document History Page

Document Title: CY7C1079DV33 32-Mbit (4 M × 8) Static RAM				
Document Number: 001-50282				
REV.	ECN NO.	Submission Date	Orig. of Change	Description of Change
**	2711136	05/29/2009	VKN/PYRS	New Data sheet Added -45B2XI part (Dual CE option)
*A	2759408	09/03/2009	VKN/AESA	Removed 10ns speed Marked thermal specs as "TBD" Changed t_{DOE} , t_{HZOE} , t_{HZCE} , t_{HZWE} specs from 6 ns to 7ns Added -12B2XI part (Dual CE option)
*B	2813370	11/23/2009	VKN	Changed I_{CC} spec from 225 mA to 250 mA
*C	3132969	01/11/2011	PRAS	Added Ordering Code Definitions . Updated Package Diagrams . Added Acronyms and Units of Measure . Changed all instances of IO to I/O. Updated in new template.
*D	3232668	04/18/2011	PRAS	Changed status from Preliminary to Final. Updated Pin Configuration (Figure 2) . Updated Thermal Resistance .

Sales, Solutions, and Legal Information

Worldwide Sales and Design Support

Cypress maintains a worldwide network of offices, solution centers, manufacturer's representatives, and distributors. To find the office closest to you, visit us at cypress.com/sales.

Products

Automotive	cypress.com/go/automotive
Clocks & Buffers	cypress.com/go/clocks
Interface	cypress.com/go/interface
Lighting & Power Control	cypress.com/go/powerpsoc cypress.com/go/plc
Memory	cypress.com/go/memory
Optical & Image Sensing	cypress.com/go/image
PSoC	cypress.com/go/psoc
Touch Sensing	cypress.com/go/touch
USB Controllers	cypress.com/go/USB
Wireless/RF	cypress.com/go/wireless

PSoC Solutions

psoc.cypress.com/solutions
PSoC 1 | PSoC 3 | PSoC 5

© Cypress Semiconductor Corporation, 2009-2011. The information contained herein is subject to change without notice. Cypress Semiconductor Corporation assumes no responsibility for the use of any circuitry other than circuitry embodied in a Cypress product. Nor does it convey or imply any license under patent or other rights. Cypress products are not warranted nor intended to be used for medical, life support, life saving, critical control or safety applications, unless pursuant to an express written agreement with Cypress. Furthermore, Cypress does not authorize its products for use as critical components in life-support systems where a malfunction or failure may reasonably be expected to result in significant injury to the user. The inclusion of Cypress products in life-support systems application implies that the manufacturer assumes all risk of such use and in doing so indemnifies Cypress against all charges.

Any Source Code (software and/or firmware) is owned by Cypress Semiconductor Corporation (Cypress) and is protected by and subject to worldwide patent protection (United States and foreign), United States copyright laws and international treaty provisions. Cypress hereby grants to licensee a personal, non-exclusive, non-transferable license to copy, use, modify, create derivative works of, and compile the Cypress Source Code and derivative works for the sole purpose of creating custom software and or firmware in support of licensee product to be used only in conjunction with a Cypress integrated circuit as specified in the applicable agreement. Any reproduction, modification, translation, compilation, or representation of this Source Code except as specified above is prohibited without the express written permission of Cypress.

Disclaimer: CYPRESS MAKES NO WARRANTY OF ANY KIND, EXPRESS OR IMPLIED, WITH REGARD TO THIS MATERIAL, INCLUDING, BUT NOT LIMITED TO, THE IMPLIED WARRANTIES OF MERCHANTABILITY AND FITNESS FOR A PARTICULAR PURPOSE. Cypress reserves the right to make changes without further notice to the materials described herein. Cypress does not assume any liability arising out of the application or use of any product or circuit described herein. Cypress does not authorize its products for use as critical components in life-support systems where a malfunction or failure may reasonably be expected to result in significant injury to the user. The inclusion of Cypress' product in a life-support systems application implies that the manufacturer assumes all risk of such use and in doing so indemnifies Cypress against all charges.

Use may be limited by and subject to the applicable Cypress software license agreement.