

CK409-Compliant Clock Synthesizer

Features

- Supports Intel® Springdale/Prescott (CK409)
- Selectable CPU frequencies
- 3.3V power supply
- Nine copies of PCI clock
- Four copies 3V66 clock with optional VCH
- Three copies 48-MHz clock
- Three copies REF clock

- Two differential CPU clock pairs
- Support SMBus/I²C Byte, Word, and Block Read/Write
- Dial-A-Frequency®
- Ideal Lexmark Spread Spectrum profile for maximum electromagnetic interference (EMI) reduction
- 48-pin SSOP package

Table 1. Frequency Table

CPU	3V66	PCI	REF	48M
x 2	x 4	x 9	x 3	x 3

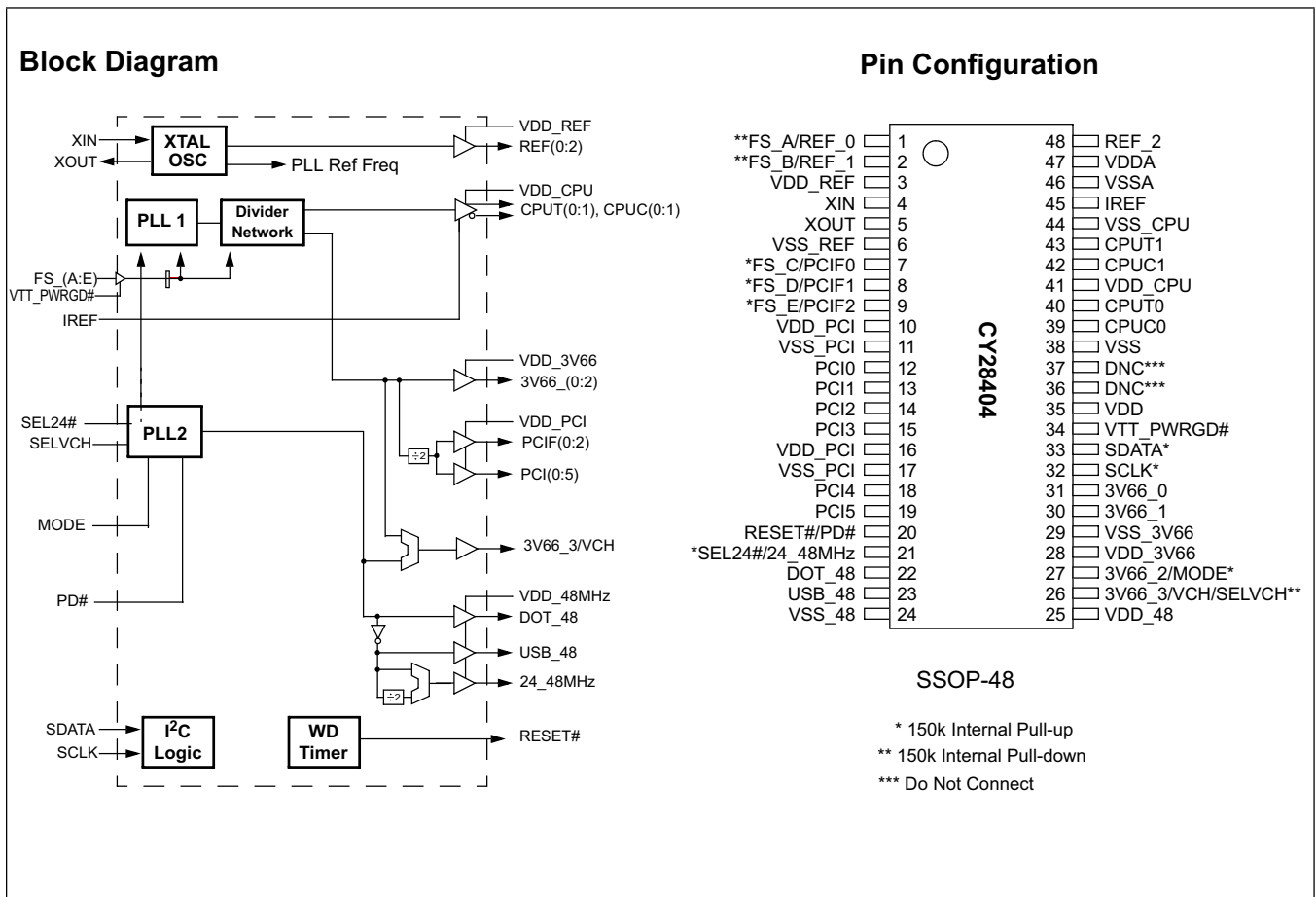

Pin Description

Pin No.	Name	Type	Description
1, 2, 48	REF(0:2)	O, SE	Reference Clock. 3.3V 14.318 MHz clock output.
1, 2, 7, 8, 9	FS_A, FS_B, FS_C, FS_D, FS_E	I	3.3V LVTTTL Latched Input for CPU Frequency Selection.
4	XIN	I	Crystal Connection or External Reference Frequency Input. This pin has dual functions. It can be used as an external 14.318 MHz crystal connection or as an external reference frequency input.
5	XOUT	O, SE	Crystal Connection. Connection for an external 14.318 MHz crystal output.
40, 43	CPUT(0:1)	O, DIF	CPU Clock Output. Differential CPU clock outputs.
39, 42	CPUC(0:1)	O, DIF	CPU Clock Output. Differential CPU clock outputs.
37, 36	DNC		Do Not Connect
30, 31	3V66(0:1)	O, SE	66 MHz Clock Output. 3.3V 66 MHz clock from internal VCO.
26	3V66_3/VCH/ SELVCH	I/O, SE PD	48 or 66 MHz Clock Output. 3.3V selectable through external SELVCH strapping resistor and SMBus to be 66 MHz or 48 MHz. Default is 66 MHz. 0 = 66 MHz, 1 = 48 MHz
27	3V66_2/MODE	I/O, SE PU	66 MHz Clock Output. 3.3V 66 MHz clock from internal VCO. Reset or Power-down Mode Select. Selects between RESET# output or PWRDWN# input for the PWRDWN#/RESET# pin. Default is RESET#. 0 = PD, 1 = RESET.
7, 8, 9	PCI_F(0:2)	O, SE,PU	Free Running PCI Output. 33 MHz clocks divided down from 3V66.
12, 13, 14, 15, 18, 19	PCI(0:5)	O, SE	PCI Clock Output. 33 MHz clocks divided down from 3V66.
23	USB_48	O, SE	Fixed 48 MHz Clock Output.
22	DOT_48	O, SE	Fixed 48 MHz Clock Output.
45	IREF	I	Current Reference. A precision resistor is attached to this pin which is connected to the internal current reference.
20	RESET#/PD#	I/O, PU	3.3V LVTTTL Input for PowerDown# active LOW. Watchdog Time-out Reset Output.
21	SEL24#/ 24_48MHz	I/O, SE PU	24 or 48 MHz Output. 3.3V fixed 24 MHz or 48 MHz non-spread spectrum output selectable through an external power-on strapping resistor tied to this pin. 0 = 24 MHz, 1 = 48 MHz
34	VTT_PWRGD#	I	3.3V LVTTTL Input is a Level Sensitive Strobe used to Latch the FS[A:E] Input (active LOW).
33	SDATA	I/O	SMBus-compatible SDATA.
32	SCLK	I	SMBus-compatible SCLOCK.
47	VDDA	PWR	3.3V Power Supply for PLL.
46	VSSA	GND	Ground for PLL.
3, 10, 16, 25, 28, 35, 41	VDD(REF,PCI,48,3 V66,CPU),	PWR	3.3V Power Supply for Outputs.
6, 11, 17, 29, 38, 44, 46	VSS(REF,PCI,48,3V 66,CPU,ITP)	GND	Ground for Outputs.

MODE Select

The hardware strapping MODE input pin can be used to select the functionality of the RESET#/PD# pin. The default (internal pull-up) configuration is for this pin to function as a RESET# Watchdog output. When pulled LOW during device Power-up, the RESET#/PD# pin will be configured to function as a Power-down input pin.

Frequency Select Pins

Host clock frequency selection is achieved by applying the appropriate logic levels to FS_A through FS_E inputs prior to VTT_PWRGD# assertion (as seen by the clock synthesizer). Upon VTT_PWRGD# being sampled LOW by the clock chip (indicating processor VTT voltage is stable), the clock chip samples the FS_A through FS_E input values. For all logic levels of FS_A through FS_E VTT_PWRGD# employs a one-shot functionality in that once a valid LOW on VTT_PWRGD# has been sampled, all further VTT_PWRGD# and FS_A through FS_E transitions will be ignored.

Table 2. Frequency Selection Table

Input Conditions					Output Frequency			VCO Freq.	PLL Gear Constants (G)
FS_E	FS_D	FS_C	FS_B	FS_A	CPU	3V66	PCI		
FSEL_4	FSEL_3	FSEL_2	FSEL_1	FSEL_0					
0	0	0	0	0	100.7	67.1	33.6	805.6	24004009.32
0	0	0	0	1	100.2	66.8	33.4	801.6	24004009.32
0	0	0	1	0	108.0	72.0	36.0	864.0	24004009.32
0	0	0	1	1	101.2	67.5	33.7	809.6	24004009.32
0	0	1	0	0	Reserved	Reserved	Reserved	Reserved	Reserved
0	0	1	0	1	Reserved	Reserved	Reserved	Reserved	Reserved
0	0	1	1	0	Reserved	Reserved	Reserved	Reserved	Reserved
0	0	1	1	1	Reserved	Reserved	Reserved	Reserved	Reserved
0	1	0	0	0	125.7	62.9	31.4	754.2	32005345.76
0	1	0	0	1	130.3	65.1	32.6	781.6	32005345.76
0	1	0	1	0	133.6	66.8	33.4	801.6	32005345.76
0	1	0	1	1	134.2	67.1	33.6	805.2	32005345.76
0	1	1	0	0	134.5	67.3	33.6	807.0	32005345.76
0	1	1	0	1	148.0	74.0	37.0	888.0	32005345.76
0	1	1	1	0	Reserved	Reserved	Reserved	Reserved	Reserved
0	1	1	1	1	Reserved	Reserved	Reserved	Reserved	Reserved
1	0	0	0	0	Reserved	Reserved	Reserved	Reserved	Reserved
1	0	0	0	1	Reserved	Reserved	Reserved	Reserved	Reserved
1	0	0	1	0	167.4	55.8	27.9	669.6	48008018.65
1	0	0	1	1	170.0	56.7	28.3	680.0	48008018.65
1	0	1	0	0	175.0	58.3	29.2	700.0	48008018.65
1	0	1	0	1	180.0	60.0	30.0	720.0	48008018.65
1	0	1	1	0	185.0	61.7	30.8	740.0	48008018.65
1	0	1	1	1	190.0	63.3	31.7	760.0	48008018.65
1	1	0	0	0	100.9	67.3	33.6	807.2	24004009.32
1	1	0	0	1	133.9	67.0	33.5	803.4	32005345.76
1	1	0	1	0	200.9	67.0	33.5	803.6	48008018.65
1	1	0	1	1	Reserved	Reserved	Reserved	Reserved	Reserved
1	1	1	0	0	100.0	66.7	33.3	800.0	24004009.32
1	1	1	0	1	133.3	66.7	33.3	800.0	32005345.76
1	1	1	1	0	200.0	66.7	33.3	800.0	48008018.65
1	1	1	1	1	Reserved	Reserved	Reserved	Reserved	Reserved

Serial Data Interface

To enhance the flexibility and function of the clock synthesizer, a two-signal serial interface is provided. Through the Serial Data Interface, various device functions, such as individual clock output buffers, can be individually enabled or disabled. The registers associated with the Serial Data Interface initialize to their default setting upon power-up, and therefore use of this interface is optional. The interface can also be accessed during power down operation.

Data Protocol

The clock driver serial protocol accepts Byte Write, Byte Read, Block Write and Block Read operation from any external I²C controller. For Block Write/Read operation, the bytes must be accessed in sequential order from lowest to highest byte (most significant bit first) with the ability to stop after any complete byte has been transferred. For Byte Write and Byte Read operations, the system controller can access individual indexed bytes. The offset of the indexed byte is encoded in the command code, as described in *Table 3*.

The Block Write and Block Read protocol is outlined in *Table 4* while *Table 5* outlines the corresponding Byte Write and Byte Read protocol. The slave receiver address is 11010010 (D2h).

Table 3. Command Code Definition

Bit	Description
7	0 = Block Read or Block Write operation 1 = Byte Read or Byte Write operation
(6:0)	Byte offset for Byte Read or Byte Write operation. For Block Read or Block Write operations, these bits should be '0000000'

Table 4. Block Read and Block Write protocol

Block Write Protocol		Block Read Protocol	
Bit	Description	Bit	Description
1	Start	1	Start
2:8	Slave address – 7 bits	2:8	Slave address – 7 bits
9	Write	9	Write
10	Acknowledge from slave	10	Acknowledge from slave
11:18	Command Code – 8-bit '00000000' stands for block operation	11:18	Command Code – 8-bit '00000000' stands for block operation
19	Acknowledge from slave	19	Acknowledge from slave
20:27	Byte Count – 8 bits	20	Repeat start
28	Acknowledge from slave	21:27	Slave address – 7 bits
29:36	Data byte 0 – 8 bits	28	Read
37	Acknowledge from slave	29	Acknowledge from slave
38:45	Data byte 1 – 8 bits	30:37	Byte count from slave – 8 bits
46	Acknowledge from slave	38	Acknowledge
....	Data Byte N/Slave Acknowledge...	39:46	Data byte from slave – 8 bits
....	Data Byte N – 8 bits	47	Acknowledge
....	Acknowledge from slave	48:55	Data byte from slave – 8 bits
....	Stop	56	Acknowledge
		Data bytes from slave/Acknowledge
		Data byte N from slave – 8 bits
		Not Acknowledge
		Stop

Table 5. Byte Read and Byte Write Protocol

Byte Write Protocol		Byte Read Protocol	
Bit	Description	Bit	Description
1	Start	1	Start
2:8	Slave address – 7 bits	2:8	Slave address – 7 bits
9	Write = 0	9	Write = 0
10	Acknowledge from slave	10	Acknowledge from slave
11:18	Command Code – 8 bits '1xxxxxx' stands for byte operation, bits[6:0] of the command code represents the offset of the byte to be accessed	11:18	Command Code – 8 bits '1xxxxxx' stands for byte operation, bits[6:0] of the command code represents the offset of the byte to be accessed
19	Acknowledge from slave	19	Acknowledge from slave
20:27	Data byte from master – 8 bits	20	Repeat start
28	Acknowledge from slave	21:27	Slave address – 7 bits
29	Stop	28	Read = 1
		29	Acknowledge from slave
		30:37	Data byte from slave – 8 bits
		38	Not Acknowledge
		39	Stop

Byte 0: Control Register 0

Bit	@Pup	Name	Description
7	0	Reserved	Reserved, set = 0
6	1	PCIF PCI	PCI Drive Strength Override 0 = Force All PCI and PCIF Outputs to Low Drive Strength 1 = Force All PCI and PCIF Outputs to High Drive Strength
5	0	Reserved	Reserved, set = 0
4	HW	FS_E	Power up latched value of FS_E pin
3	HW	FS_D	Power up latched value of FS_D pin
2	HW	FS_C	Power up latched value of FS_C pin
1	HW	FS_B	Power up latched value of FS_B pin
0	HW	FS_A	Power up latched value of FS_A pin

Byte 1: Control Register 1

Bit	@Pup	Name	Description
7	0	Reserved	Reserved, set = 0
6	1	Reserved	Reserved, set = 1
5	1	Reserved	Reserved, set = 1
4	1	Reserved	Reserved, set = 1
3	1	Reserved	Reserved, set = 1
2	1	Reserved	Reserved, set = 1
1	1	CPUT1, CPUC1	CPU(T/C)1 Output Enable, 0 = Disabled (three-state), 1 = Enabled
0	1	CPUT0, CPUC0	CPU(T/C)0 Output Enable 0 = Disabled (three-state), 1 = Enabled

Byte 2: Control Register 2

Bit	@Pup	Name	Description
7	0	Reserved	Reserved, set = 0
6	0	Reserved	Reserved, set = 0
5	0	Reserved	Reserved, set = 0
4	0	CPUT1, CPUC1	CPU(T/C)1 Pwrdsn drive mode 0 = Driven in power down, 1 = Three-state
3	0	CPUT0, CPUC0	CPU(T/C)0 Pwrdsn drive mode 0 = Driven in power down, 1 = Three-state
2	0	Reserved	Reserved, set = 0
1	0	Reserved	Reserved, set = 0
0	0	Reserved	Reserved, set = 0

Byte 3: Control Register 3

Bit	@Pup	Name	Description
7	1	SW PCI STOP	SW PCI_STP Function 0= PCI_STP assert, 1= PCI_STP de-assert When this bit is set to 0, all STOPPABLE PCI and PCIF outputs will be stopped in a synchronous manner with no short pulses. When this bit is set to 1, all STOPPED PCI and PCIF outputs will resume in a synchronous manner with no short pulses.
6	1	Reserved	Reserved, set = 1
5	1	PCI5	PCI5 Output Enable 0 = Disabled, 1 = Enabled
4	1	PCI4	PCI4 Output Enable 0 = Disabled, 1 = Enabled
3	1	PCI3	PCI3 Output Enable 0 = Disabled, 1 = Enabled
2	1	PCI2	PCI2 Output Enable 0 = Disabled, 1 = Enabled
1	1	PCI1	PCI1 Output Enable 0 = Disabled, 1 = Enabled
0	1	PCI0	PCI0 Output Enable 0 = Disabled, 1 = Enabled

Byte 4: Control Register 4

Bit	@Pup	Name	Description
7	0	USB_48 and 24_48MHz	USB_48 and 24_48MHz Drive Strength Control 0 = High Drive Strength, 1 = Low Drive Strength
6	1	USB_48	USB_48 Output Enable 0 = Disabled, 1 = Enabled
5	0	PCIF2	Allow control of PCIF2 with assertion of SW PCI_STP 0 = Free Running, 1 = Stopped with SW PCI_STP
4	0	PCIF1	Allow control of PCIF1 with assertion of SW PCI_STP 0 = Free Running, 1 = Stopped with SW PCI_STP
3	0	PCIF0	Allow control of PCIF0 with assertion of SW PCI_STP 0 = Free Running, 1 = Stopped with SW PCI_STP
2	1	PCIF2	PCIF2 Output Enable 0 = Disabled, 1 = Enabled
1	1	PCIF1	PCIF1 Output Enable 0 = Disabled, 1 = Enabled
0	1	PCIF0	PCIF0 Output Enable 0 = Disabled, 1 = Enabled

Byte 5: Control Register 5

Bit	@Pup	Name	Description
7	1	DOT_48	DOT_48 Output Enable 0 = Disabled, 1 = Enabled
6	1	Reserved	Reserved, set = 1
5	HW	3V66_3/VCH/SELVCH	3V66_3/VCH/SELVCH Frequency Select 0 = 3V66 mode 1 = VCH (48 MHz) mode May be written to override the power up value.
4	1	3V66_3/VCH/SELVCH	3V66_3/VCH/SELVCH Output Enable 0 = Disabled 1 = Enabled
3	1	Reserved	Reserved, set = 1
2	1	3V66_2	3V66_2 Output Enable 0 = Disabled, 1 = Enabled
1	1	3V66_1	3V66_1 Output Enable 0 = Disabled, 1 = Enabled
0	1	3V66_0	3V66_0 Output Enable 0 = Disabled, 1 = Enabled

Byte 6: Control Register 6

Bit	@Pup	Name	Description
7	0	Reserved	Reserved, set = 0
6	0	Reserved	Reserved, set = 0
5	0	Reserved	Reserved, set = 0
4	0	Reserved	Reserved, set = 0
3	0	Reserved	Reserved, set = 0
2	0	PCIF PCI 3V66 CPUT,CPUC	Spread Spectrum Enable 0 = Spread Off, 1 = Spread On
1	1	REF_1	REF_1 Output Enable 0 = Disabled, 1 = Enabled
0	1	REF_0	REF_0 Output Enable 0 = Disabled, 1 = Enabled

Byte 7: Vendor ID

Bit	@Pup	Name	Description
7	0	Revision ID Bit 3	Revision ID Bit 3
6	1	Revision ID Bit 2	Revision ID Bit 2
5	0	Revision ID Bit 1	Revision ID Bit 1
4	0	Revision ID Bit 0	Revision ID Bit 0
3	1	Vendor ID Bit 3	Vendor ID Bit 3
2	0	Vendor ID Bit 2	Vendor ID Bit 2
1	0	Vendor ID Bit 1	Vendor ID Bit 1
0	0	Vendor ID Bit 0	Vendor ID Bit 0

Byte 8: Control Register 8

Bit	@Pup	Name	Description
7	0	CPU	Spread Spectrum Selection '000' = $\pm 0.20\%$ triangular '001' = + 0.12, - 0.62% '010' = + 0.25, - 0.75% '011' = -0.05, - 0.45% triangular '100' = $\pm 0.25\%$ '101' = + 0.00, - 0.50% '110' = $\pm 0.5\%$ '111' = $\pm 0.38\%$
6	1	PCIF	
5	1	PCI	
		3V66	
4	0	FSEL_4	SW Frequency selection bits. See <i>Table 2</i> .
3	0	FSEL_3	
2	0	FSEL_2	
1	0	FSEL_1	
		FSEL_0	
0	0	FSEL_0	

Byte 9: Control Register 9

Bit	@Pup	Name	Description
7	0	PCIF	PCIF Clock Output Drive Strength Control 0 = Low Drive strength, 1 = High Drive strength
6	0	PCI	PCI Clock Output Drive Strength 0 = Low Drive strength, 1 = High Drive strength
5	0	3V66	3V66 Clock Output Drive Strength 0 = Low Drive strength, 1 = High Drive strength
4	1	REF	REF Clock Output Drive Strength 0 = Low Drive Strength, 1 = High Drive Strength
3	1	24_48MHz	24_48MHz Output Enable 0 = Disabled, 1 = Enabled
2	1	REF_2	REF_2 Output Enable 0 = Disabled, 1 = Enabled
1	0	Reserved	Reserved, set = 0
0	0	Reserved	Reserved, set = 0

Byte 10: Control Register 10

Bit	@Pup	Name	Description
7	0	PCI_Skew1	PCI skew control 00 = Normal 01 = -500 ps 10 = Reserved 11 = +500 ps
6	0	PCI_Skew0	
5	0	3V66_Skew1	3V66 skew control 00 = Normal 01 = -150 ps 10 = +150 ps 11 = +300 ps
4	0	3V66_Skew0	
3	1	Reserved	Reserved, Set = 1
2	1	Reserved	Reserved, Set = 1
1	1	Reserved	Reserved, Set = 1
0	1	Reserved	Reserved, Set = 1

Byte 11: Control Register 11

Bit	@Pup	Name	Description
7	0	Reserved	Reserved, set = 0
6	0	Recovery_Frequency	This bit allows selection of the frequency setting that the clock will be restored to once the system is rebooted 0: Use Hardware settings 1: Use Last SW table Programmed values
5	0	Watchdog Time Stamp Reload	To enable this function the register bit must first be set to "0" before toggling to "1". 0: Do not reload 1: Reset timer but continue to count.
4	0	WD_Alarm	This bit is set to "1" when the Watchdog times out. It is reset to "0" when the system clears the WD_TIMER time stamp
3	0	WD_TIMER3	Watchdog timer time stamp selection: 0000: Off 0001: 2 second 0010: 4 seconds 0011: 6 seconds . . . 1110: 28 seconds 1111: 30 seconds
2	0	WD_TIMER2	
1	0	WD_TIMER1	
0	0	WD_TIMER0	

Byte 12: Control Register 12

Bit	@Pup	Name	Description
7	0	CPU_FSEL_N8	If Prog_Freq_EN is set, the values programmed in CPU_FSEL_N[8:0] and CPU_FSEL_M[6:0] will be used to determine the CPU output frequency. The setting of FS_Override bit determines the frequency ratio for CPU and other output clocks. When it is cleared, the same frequency ratio stated in the Latched FS[E:A] register will be used. When it is set, the frequency ratio stated in the SEL[4:0] register will be used.
6	0	CPU_FSEL_N7	
5	0	CPU_FSEL_N6	
4	0	CPU_FSEL_N5	
3	0	CPU_FSEL_N4	
2	0	CPU_FSEL_N3	
1	0	CPU_FSEL_N2	
0	0	CPU_FSEL_N1	

Byte 13: Control Register 13

Bit	@Pup	Name	Description
7	0	CPU_FSEL_N0	If Prog_Freq_EN is set, the values programmed in CPU_FSEL_N[8:0] and CPU_FSEL_M[6:0] will be used to determine the CPU output frequency. The setting of FS_Override bit determines the frequency ratio for CPU and other output clocks. When it is cleared, the same frequency ratio stated in the Latched FS[E:A] register will be used. When it is set, the frequency ratio stated in the SEL[4:0] register will be used.
6	0	CPU_FSEL_M6	
5	0	CPU_FSEL_M5	
4	0	CPU_FSEL_M4	
3	0	CPU_FSEL_M3	
2	0	CPU_FSEL_M2	
1	0	CPU_FSEL_M1	
0	0	CPU_FSEL_M0	

Byte 14: Control Register 14

Bit	@Pup	Name	Description
7	0	FS_(E:A)	FS_Override 0 = Select operating frequency by FS(E:A) input pins 1 = Select operating frequency by FSEL(4:0) settings
6	0	Reserved	Reserved, set = 0
5	0	Reserved	Reserved, set = 0

Byte 14: Control Register 14 (continued)

Bit	@Pup	Name	Description
4	0	Reserved	Reserved, set = 0
3	0	Reserved	Reserved, set = 0
2	0	Reserved	Reserved, set = 0
1	0	Reserved	Reserved, set = 0
0	0	Pro_Freq_EN	Programmable output frequencies enabled 0 = disabled, 1 = enabled

Dial-A-Frequency Programming

When the programmable output frequency feature is enabled (Pro_Freq_EN bit is set), the CPU output frequency is determined by the following equation:

$$F_{cpu} = G * N/M.$$

“N” and “M” are the values programmed in Programmable Frequency Select N-Value Register and M-Value Register, respectively.

“G” stands for the PLL Gear Constant, which is determined by the programmed value of FS[E:A] or SEL[4:0]. The value is listed in *Table 2*.

The ratio of N and M needs to be greater than “1” [N/M > 1].

Table 6 lists set of N and M values for different frequency output ranges. This example use a fixed value for the M-Value Register and select the CPU output frequency by changing the value of the N-Value Register.

Table 6. Examples of N and M Value for Different CPU Frequency Range

Frequency Ranges	Gear Constants	Fixed Value for M-Value Register	Range of N-Value Register for Different CPU Frequency
100—125	24004009.32	48	200–250
126—166	32005345.76	48	189–249
167—200	48008018.65	48	167–200

Table 7. Crystal Recommendations

Frequency (Fund)	Cut	Loading	Load Cap	Drive (max.)	Shunt Cap (max.)	Motional (max.)	Tolerance (max.)	Stability (max.)	Aging (max.)
14.31818 MHz	AT	Parallel	20 pF	0.1 mW	5 pF	0.016 pF	50 ppm	50 ppm	5 ppm

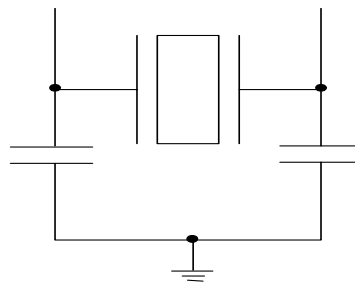
Figure 1. Crystal Capacitive Clarification
Crystal Recommendations

The CY28404 requires a **Parallel Resonance Crystal**. Substituting a series resonance crystal will cause the CY28404 to operate at the wrong frequency and violate the ppm specification. For most applications there is a 300-ppm frequency shift between series and parallel crystals due to incorrect loading.

Crystal Loading

Crystal loading plays a critical role in achieving low ppm performance. To realize low ppm performance, the total capacitance the crystal will see must be considered to calculate the appropriate capacitive loading (CL).

Figure 1 shows a typical crystal configuration using the two trim capacitors. An important clarification for the following discussion is that the trim capacitors are in series with the crystal not parallel. It’s a common misconception that load capacitors are in parallel with the crystal and should be approximately equal to the load capacitance of the crystal. This is **not true**.

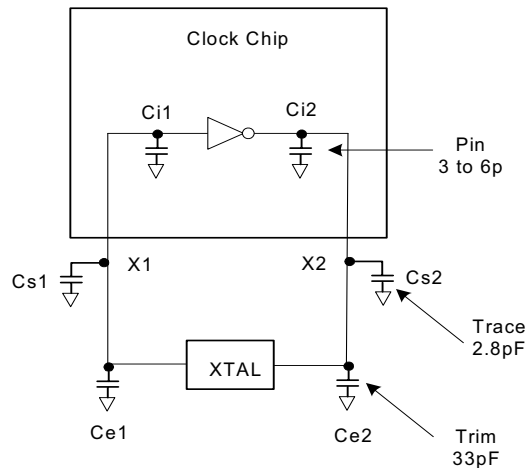

Figure 2. Crystal Loading Example

Calculating Load Capacitors

In addition to the standard external trim capacitors, trace capacitance and pin capacitance must also be considered to correctly calculate crystal loading. As mentioned previously, the capacitance on each side of the crystal is in series with the crystal. This means the total capacitance on each side of the crystal must be twice the specified crystal load capacitance (C_L). While the capacitance on each side of the crystal is in series with the crystal, trim capacitors (CE1,CE2) should be calculated to provide equal capacitive loading on both sides.

As mentioned previously, the capacitance on each side of the crystal is in series with the crystal. This means the total capacitance on each side of the crystal must be twice the specified load capacitance (C_L). While the capacitance on each side of the crystal is in series with the crystal, trim capacitors(CE1,CE2) should be calculated to provide equal capacitive loading on both sides.

Use the following formulas to calculate the trim capacitor values for CE1 and CE2.

Load Capacitance (each side)

$$C_e = 2 * C_L - (C_s + C_i)$$

Total Capacitance (as seen by the crystal)

$$C_{Le} = \frac{1}{\left(\frac{1}{C_{e1} + C_{s1} + C_{i1}} + \frac{1}{C_{e2} + C_{s2} + C_{i2}} \right)}$$

- CL Crystal load capacitance
- CLeActual loading seen by crystal
.....using standard value trim capacitors
- CeExternal trim capacitors
- Cs.....Stray capacitance (trace,etc.)
- Ci Internal capacitance (lead frame, bond wires etc.)

PD# (Power-down) Clarification

The PD# pin is used to shut off all clocks and PLLs without having to remove power from the device. All clocks are shut down in a synchronous manner so has not to cause glitches while transitioning to the power down state.

PD# – Assertion

When PD# is sampled LOW by two consecutive rising edges of the CPUC clock then all clock outputs (except CPUT) clocks must be held LOW on their next HIGH to LOW transition. CPU clocks must be held with CPUT clock pin driven HIGH with a value of 2x Iref and CPUC undriven as the default condition. There exists an I2C bit that allows for the CPUT/C outputs to be three-stated during power-down. Due to the state of internal logic, stopping and holding the REF clock outputs in the LOW state may require more than one clock cycle to complete.

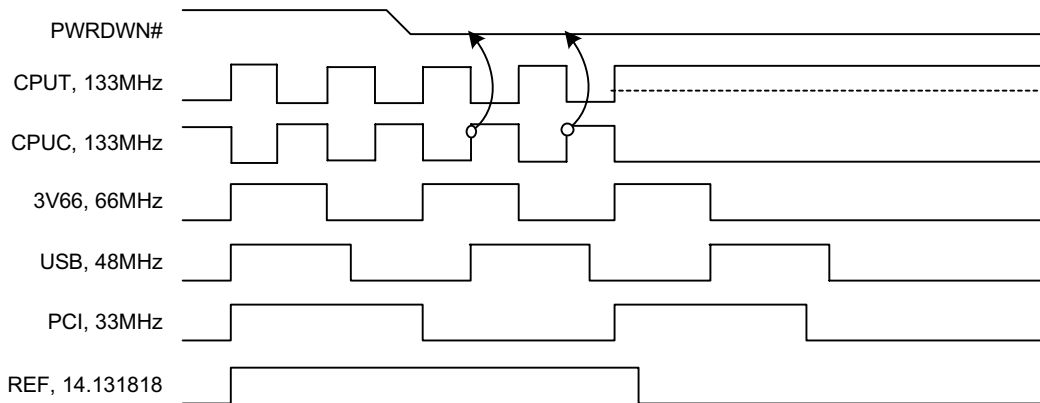

Figure 3. Power-down Assertion Timing Waveforms

PD# Deassertion

The power-up latency between PD# rising to a valid logic '1' level and the starting of all clocks is less than 1.8 ms. The CPUT/C outputs must be driven to greater than 200 mV is less than 300 μ s.

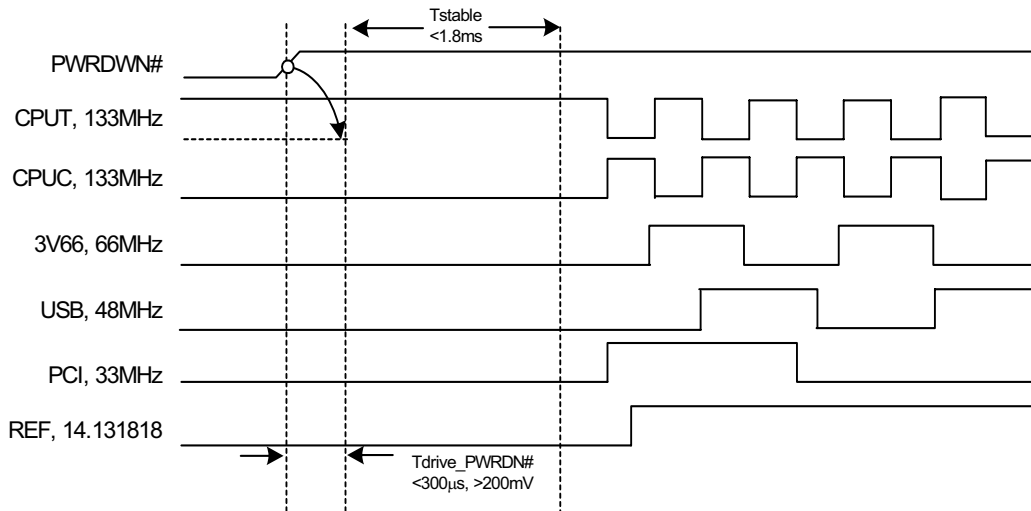
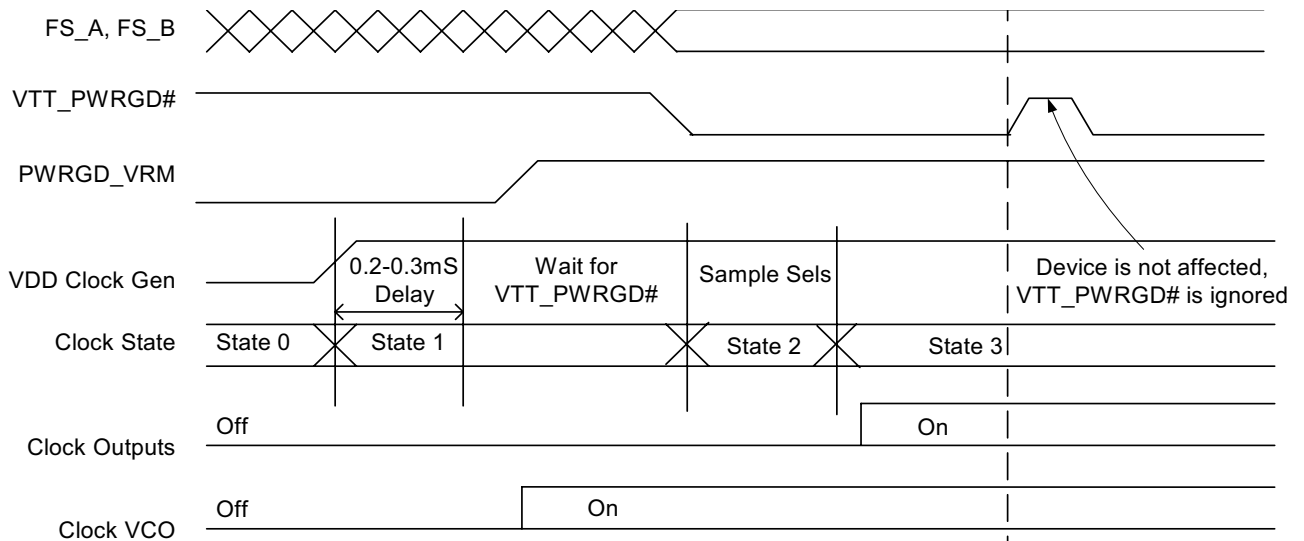
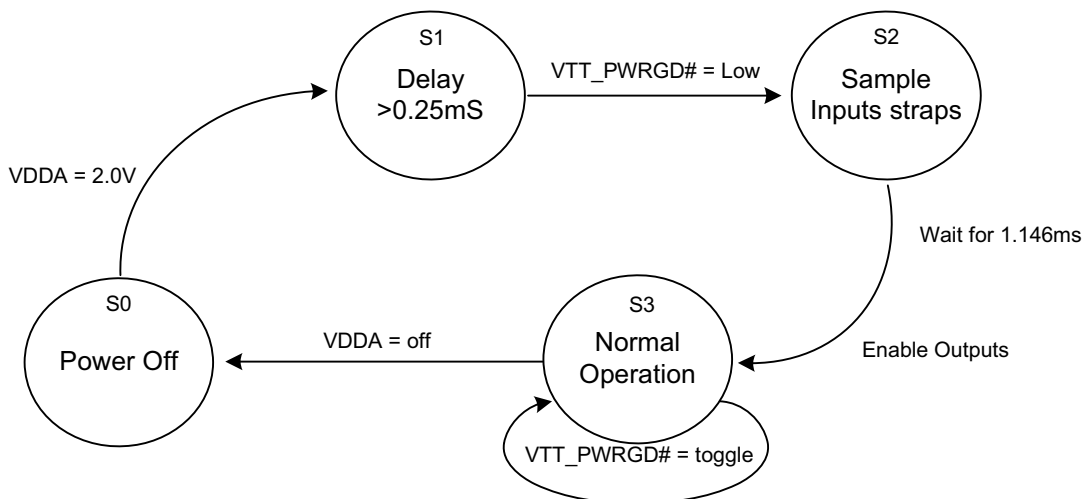

Figure 4. Power-down Deassertion Timing Waveforms

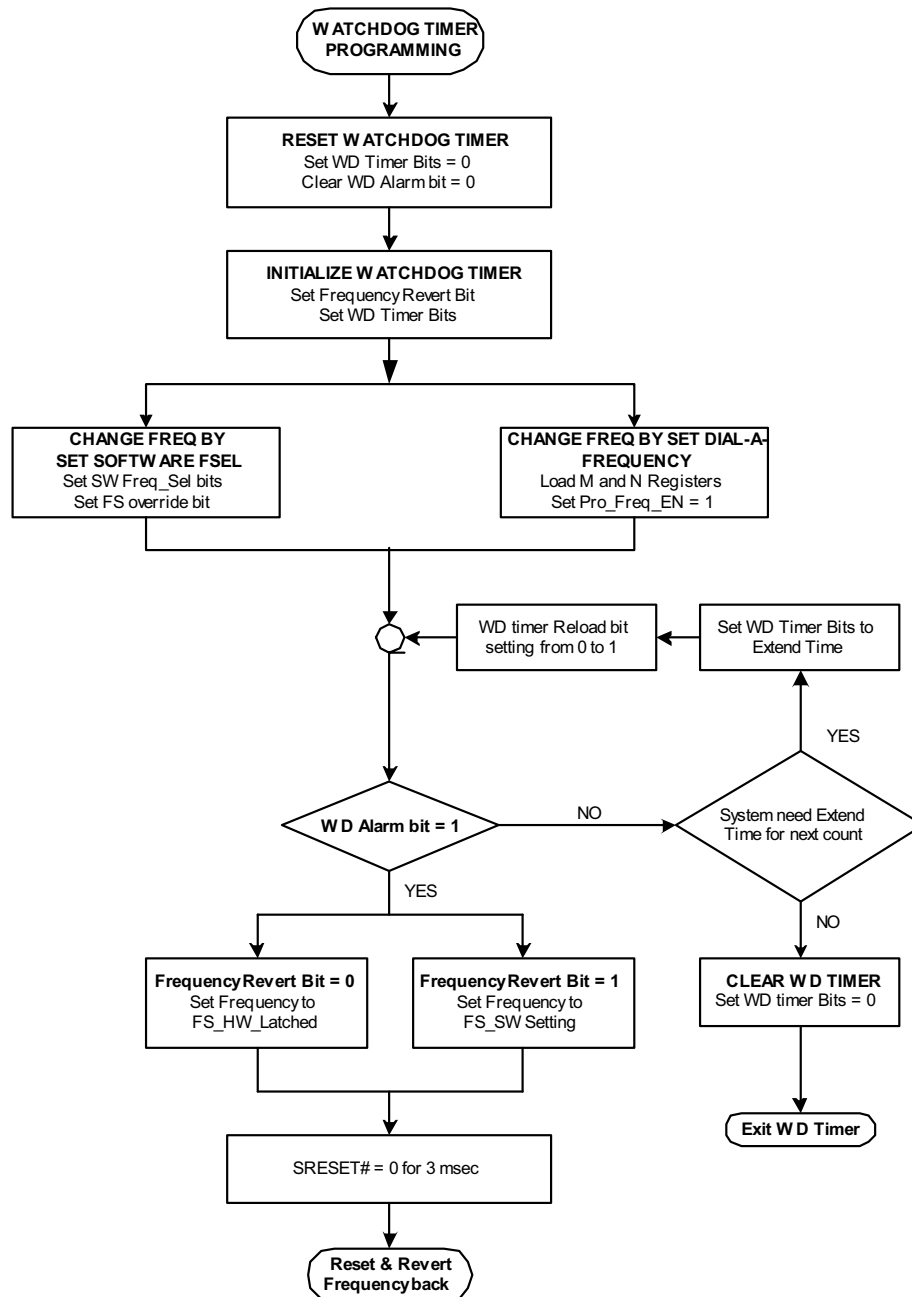

Figure 5. VTT_PWRGD Timing Diagram

Figure 6. Clock Generator Power-up/Run State Diagram

Watchdog Self Recovery Sequence

This feature is designed to allow the system designer to change frequency while the system is running and reboot the operation of the system in case of a hang up due to the frequency change. When the system sends an SMBus command requesting a frequency change through the Dial-a-Frequency Control Registers, it must have previously sent a command to the Watchdog Timer to select which time-out stamp the Watchdog must perform, otherwise the System Self Recovery feature will not be applicable. Consequently, this device will change frequency and then the Watchdog timer starts timing. Meanwhile, the system BIOS is

running its operation with the new frequency. If this device receives a new SMBus command to clear the bits originally programmed in the Watchdog Timer bits (reprogram to 0000) before the Watchdog times out, then this device will keep operating in its normal condition with the new selected frequency.

The Watchdog timer will also be triggered if you program the software frequency select bits (FSEL) to a new frequency selection. If the Watchdog times out before the new SMBus reprograms the Watchdog Timer bits to (0000), then this device will send a low system reset pulse, on SRESET# and changes WD Time-out bit to "1".

Figure 7. Watchdog Self-Recovery Sequence Flowchart

Absolute Maximum Conditions

Parameter	Description	Condition	Min.	Max.	Unit
V _{DD}	Core Supply Voltage		-0.5	4.6	V
V _{DDA}	Analog Supply Voltage		-0.5	4.6	V
V _{IN}	Input Voltage	Relative to V _{SS}	-0.5	V _{DD} + 0.5	VDC
T _S	Temperature, Storage	Non-functional	-65	+150	°C
T _A	Temperature, Operating Ambient	Functional	0	70	°C
T _J	Temperature, Junction	Functional	-	150	°C
ESD _{HBM}	ESD Protection (Human Body Model)	MIL-STD-883, Method 3015	2000	-	V
∅ _{JC}	Dissipation, Junction to Case	Mil-Spec 883E Method 1012.1	15		°C/W
∅ _{JA}	Dissipation, Junction to Ambient	JEDEC (JESD 51)	45		°C/W
UL-94	Flammability Rating	At 1/8 in.	V-0		
MSL	Moisture Sensitivity Level		1		

Multiple Supplies: The Voltage on any input or I/O pin cannot exceed the power pin during power-up. Power supply sequencing is NOT required.

DC Electrical Specifications

Parameter	Description	Conditions	Min.	Max.	Unit
V _{DD} , V _{DDA}	3.3 Operating Voltage	3.3V ± 5%	3.135	3.465	V
V _{IL12C}	Input Low Voltage	SDATA, SCLK	-	-	1.0
V _{IH12C}	Input High Voltage	SDATA, SCLK	2.2	-	-
V _{IL}	Input Low Voltage		V _{SS} -0.5	0.8	V
V _{IH}	Input High Voltage		2.0	V _{DD} +0.5	V
I _{IL}	Input Leakage Current	Except Pull-ups or Pull-downs 0 < V _{IN} < V _{DD}	-5	5	μA
V _{OL}	Output Low Voltage	I _{OL} = 1 mA	-	0.4	V
V _{OH}	Output High Voltage	I _{OH} = -1 mA	2.4	-	V
I _{OZ}	High-Impedance Output Current		-10	10	μA
C _{IN}	Input Pin Capacitance		2	5	pF
C _{OUT}	Output Pin Capacitance		3	6	pF
L _{IN}	Pin Inductance		-	7	nH
V _{XIH}	Xin High Voltage		0.7V _{DD}	V _{DD}	V
V _{XIL}	Xin Low Voltage		0	0.3V _{DD}	V
I _{DD}	Dynamic Supply Current	At 200-MHz and all outputs loaded per Table 10 and Figure 8	-	280	mA
I _{PD}	Power Down Supply Current	PD# Asserted	-	1	mA

AC Electrical Specifications

Parameter	Description	Conditions	Min.	Max.	Unit
Crystal					
T _{DC}	XIN Duty Cycle	The device will operate reliably with input duty cycles up to 30/70 but the REF clock duty cycle will not be within specification	47.5	52.5	%
T _{PERIOD}	XIN period	When Xin is driven from an external clock source	69.841	71.0	ns
T _R / T _F	XIN Rise and Fall Times	Measured between 0.3V _{DD} and 0.7V _{DD}	–	10.0	ns
T _{CCJ}	XIN Cycle to Cycle Jitter	As an average over 1- μ s duration	–	500	ps
L _{ACC}	Long Term Accuracy	Over 150 ms		300	ppm
CPU at 0.7V					
T _{DC}	CPUT and CPUC Duty Cycle	Measured at crossing point V _{OX}	45	55	%
T _{PERIOD}	100 MHz CPUT and CPUC Period	Measured at crossing point V _{OX}	9.9970	10.003	ns
T _{PERIOD}	133 MHz CPUT and CPUC Period	Measured at crossing point V _{OX}	7.4978	7.5023	ns
T _{PERIOD}	200 MHz CPUT and CPUC Period	Measured at crossing point V _{OX}	4.9985	5.0015	ns
T _{SKEW}	Any CPU to CPU Clock Skew	Measured at crossing point V _{OX}	–	100	ps
T _{CCJ}	CPU Cycle to Cycle Jitter	Measured at crossing point V _{OX}	–	125	ps
T _R / T _F	CPUT and CPUC Rise and Fall Times	Measured from V _{OL} = 0.175 to V _{OH} = 0.525V	175	700	ps
T _{RFM}	Rise/Fall Matching	Determined as a fraction of $2*(T_R - T_F)/(T_R + T_F)$	–	20	%
V _{HIGH}	Voltage High	Math average, see <i>Figure 8</i>	660	850	mv
V _{LOW}	Voltage Low	Math average, see <i>Figure 8</i>	–150	–	mv
V _{OX}	Crossing Point Voltage at 0.7V Swing		250	550	mv
V _{OVS}	Maximum Overshoot Voltage		–	V _{HIGH} +0.3	V
V _{UDS}	Minimum Undershoot Voltage		–0.3	–	V
V _{RB}	Ring Back Voltage	See <i>Figure 8</i> . Measure SE	–	0.2	V
3V66					
T _{DC}	3V66 Duty Cycle	Measurement at 1.5V	45	55	%
T _{PERIOD}	Spread Disabled 3V66 Period	Measurement at 1.5V	14.9955	15.0045	ns
T _{PERIOD}	Spread Enabled 3V66 Period	Measurement at 1.5V	14.9955	15.0799	ns
T _{HIGH}	3V66 High Time	Measurement at 2.4V, High drive	4.9500	–	ns
T _{LOW}	3V66 Low Time	Measurement at 0.4V, High drive	4.5500	–	ns
T _R / T _F	3V66 Rise and Fall Times	Measured between 0.4V and 2.4V, High drive	0.5	2.0	ns
T _{SKEW}	Any 3V66 to Any 3V66 Clock Skew	Measurement at 1.5V	–	250	ps
T _{CCJ}	3V66 Cycle to Cycle Jitter	Measurement at 1.5V	–	400	ps
PCI/PCIF					
T _{DC}	PCIF and PCI Duty Cycle	Measurement at 1.5V	45	55	%
T _{PERIOD}	Spread Disabled PCIF/PCI Period	Measurement at 1.5V	29.9910	30.0009	ns
T _{PERIOD}	Spread Enabled PCIF/PCI Period	Measurement at 1.5V	29.9910	30.1598	ns
T _{HIGH}	PCIF and PCI high time	Measurement at 2.4V, High drive	12.0	–	nS
T _{LOW}	PCIF and PCI low time	Measurement at 0.4V, High drive	12.0	–	nS
T _R /T _F	PCIF and PCI rise and fall times	Measured between 0.4V and 2.4V, High drive	0.5	2.0	nS
T _{SKEW}	Any PCI clock to Any PCI clock Skew	Measurement at 1.5V	–	500	pS

AC Electrical Specifications (continued)

Parameter	Description	Conditions	Min.	Max.	Unit
T _{CCJ}	PCIF and PCI Cycle to Cycle Jitter	Measurement at 1.5V	–	400	ps
DOT					
T _{DC}	Duty Cycle	Measurement at 1.5V	45	55	%
T _{PERIOD}	Period	Measurement at 1.5V	20.8271	20.8396	ns
T _{HIGH}	DOT high time	Measurement at 2.4V	8.806	10.486	nS
T _{LOW}	DOT low time	Measurement at 0.4V	8.794	10.386	nS
T _R / T _F	Rise and Fall Times	Measured between 0.4V and 2.4V	0.5	1.0	ns
T _{CCJ}	Cycle to Cycle Jitter	Measurement at 1.5V	–	350	ps
T _{SKEW}	Any 48-MHz to 48-MHz clock skew	Measurement at 1.5V	–	500	ps
USB					
T _{DC}	Duty Cycle	Measurement at 1.5V	45	55	%
T _{PERIOD}	Period	Measurement at 1.5V	20.8271	20.8396	ns
T _{HIGH}	USB High Time	Measurement at 2.4V	8.094	10.036	nS
T _{LOW}	USB Low Time	Measurement at 0.4V	7.694	9.836	nS
T _R / T _F	Rise and Fall Times	Measured between 0.4V and 2.4V	1.0	2.0	ns
T _{CCJ}	Cycle to Cycle Jitter	Measurement at 1.5V	–	350	ps
T _{SKEW}	Any 48-MHz to 48-MHz clock skew	Measurement at 1.5V	–	500	ps
REF					
T _{DC}	REF Duty Cycle	Measurement at 1.5V	45	55	%
T _{PERIOD}	REF Period	Measurement at 1.5V	69.827	69.855	ns
T _R / T _F	REF Rise and Fall Times	Measured between 0.4V and 2.4V	0.5	2.0	ns
T _{CCJ}	REF Cycle to Cycle Jitter	Measurement at 1.5V	–	1000	ps
T _{SKEW}	Any REF to REF clock skew	Measurement at 1.5V	–	500	ps
ENABLE/DISABLE and SETUP					
T _{STABLE}	All Clock Stabilization from Power-up		–	1.5	ms
T _{SS}	Stopclock Set-up Time		10.0	–	ns
T _{SH}	Stopclock Hold Time		0	–	ns

Table 8. Group Timing Relationship and Tolerances

Group	Conditions	Offset	
		Min.	Max.
3V66 to PCI	3V66 Leads PCI	1.5 ns	3.5 ns

Table 9. USB to DOT Phase Offset

Parameter	Typical	Value	Tolerance
DOT Skew	0°	0.0ns	1000 ps
USB Skew	180°	0.0ns	1000 ps
VCH Skew	0°	0.0ns	1000 ps

Table 10. Maximum Lumped Capacitive Output Loads

Clock	Max Load	Units
PCI Clocks	30	pF
3V66 Clocks	30	pF
USB Clock	20	pF
DOT Clock	10	pF
REF Clock	30	pF

Test and Measurement Set-up

For Differential CPU and SRC Output Signals

The following diagram shows lumped test load configurations for the differential Host Clock Outputs.

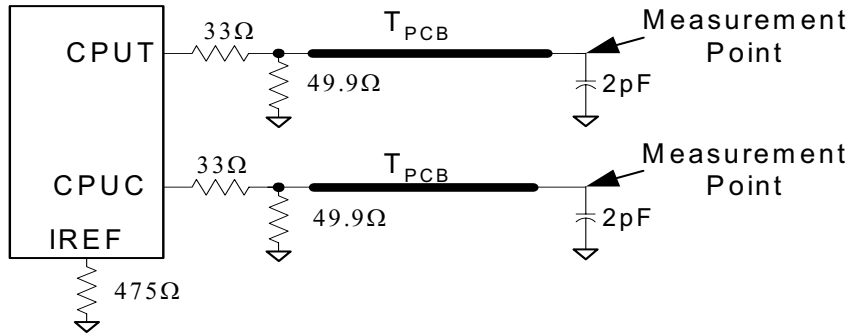
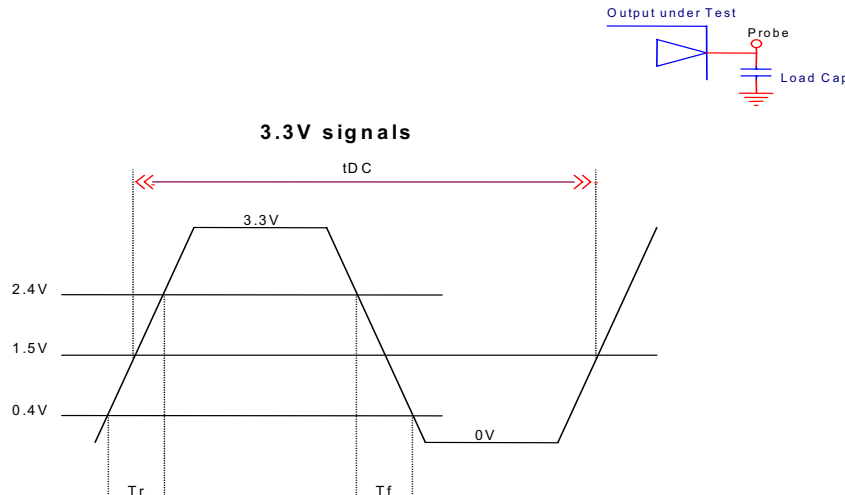
Figure 8. 0.7V Load Configuration

Figure 9. Lumped Load For Single-Ended Output Signals (for AC Parameters Measurement)
Table 11. CPU Clock Current Select Function

Board Target Trace/Term Z	Reference R, $I_{REF} - V_{DD} (3 \cdot R_{REF})$	Output Current	$V_{OH} @ Z$
50 Ohms	$R_{REF} = 475 \text{ } 1\%$, $I_{REF} = 2.32\text{mA}$	$I_{OH} = 6 \cdot I_{REF}$	0.7V @ 50

Ordering Information

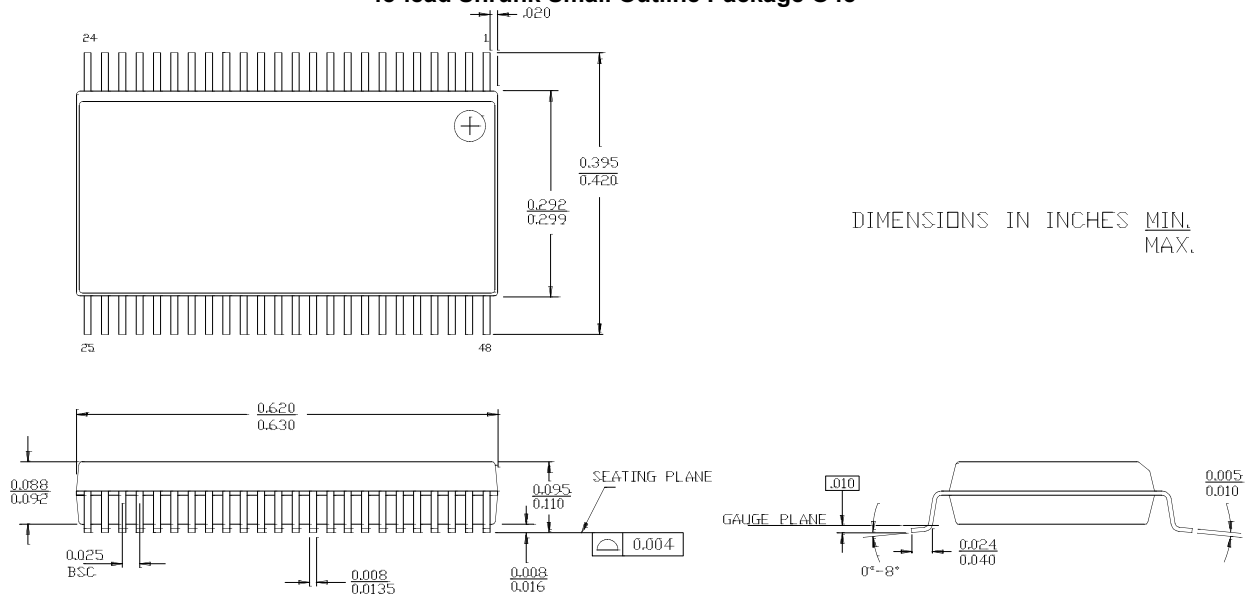
Part Number	Package Type	Product Flow
CY28404OC	48-pin Shrunk Small Outline package (SSOP)	Commercial, 0° to 70°C
CY28404OCT	48-pin Shrunk Small Outline package (SSOP) – Tape and Reel	Commercial, 0° to 70°C
Lead Free		
CY28404OXC	48-pin Shrunk Small Outline package (SSOP)	Commercial, 0° to 70°C
CY28404OXCT	48-pin Shrunk Small Outline package (SSOP) – Tape and Reel	Commercial, 0° to 70°C

Package Drawing and Dimensions
48-lead Shrunk Small Outline Package O48

While SLI has reviewed all information herein for accuracy and reliability, Spectra Linear Inc. assumes no responsibility for the use of any circuitry or for the infringement of any patents or other rights of third parties which would result from each use. This product is intended for use in normal commercial applications and is not warranted nor is it intended for use in life support, critical medical instruments, or any other application requiring extended temperature range, high reliability, or any other extraordinary environmental requirements unless pursuant to additional processing by Spectra Linear Inc., and expressed written agreement by Spectra Linear Inc. Spectra Linear Inc. reserves the right to change any circuitry or specification without notice.