

HDMI Receiver Port Protection and Interface Device

Features

- 0.05pF matching capacitance between the TMDS intra-pair
- Level shifting circuitry, including $\pm 8\text{kV}$ ESD protection on all TMDS lines
- Matched 0.5mm trace spacing (TSSOP)
- Simplified layout for HDMI connectors
- Backdrive protection

Applications

- PC
- Consumer Electronics
- Set Top Box
- Displays and Digital Television

Product Description

The CM2021 HDMI Receiver Port Protection and Interface Device is specifically designed for next generation HDMI Host interface protection.

An integrated package provides all ESD, level shift and backdrive protection for an HDMI port in a single 38-Pin TSSOP package.

The CM2021 part is specifically designed to complement the CM2020 protection part in HDMI receivers (Displays, CE devices, etc.)

Electrical Schematic

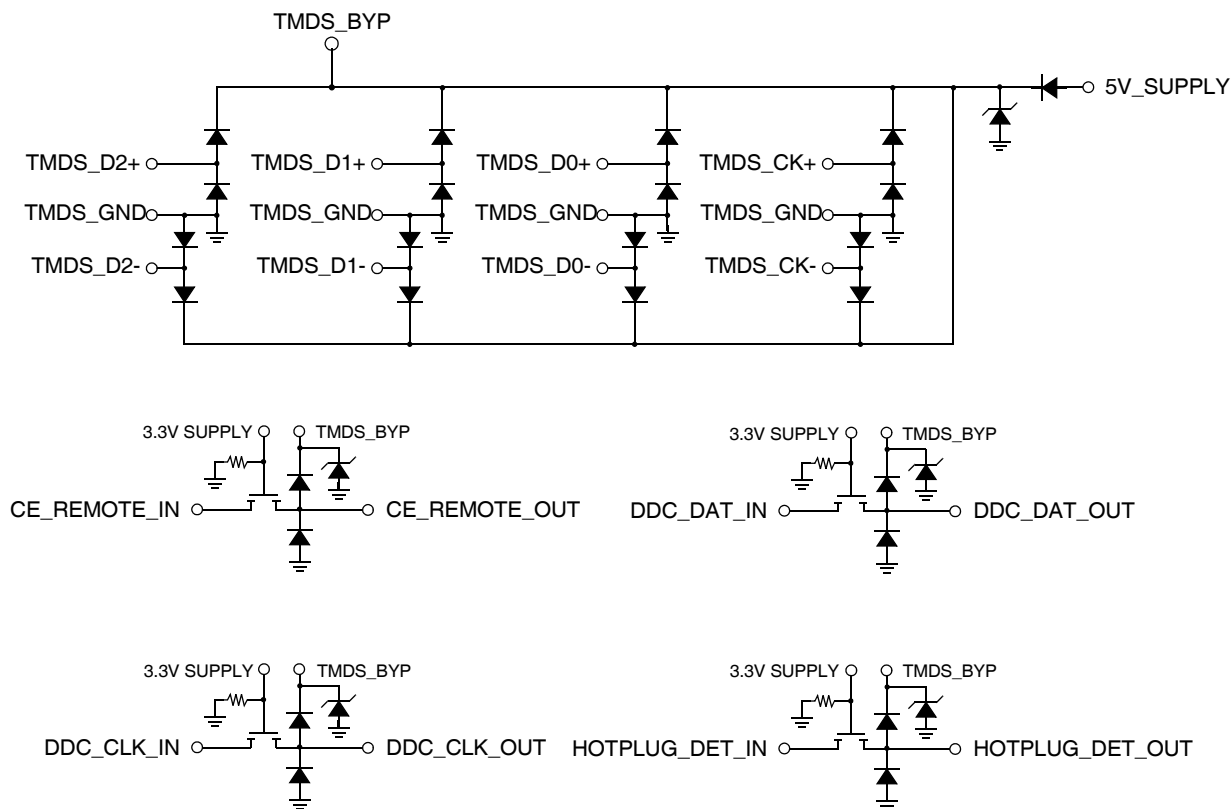

PACKAGE / PINOUT DIAGRAM

TOP VIEW

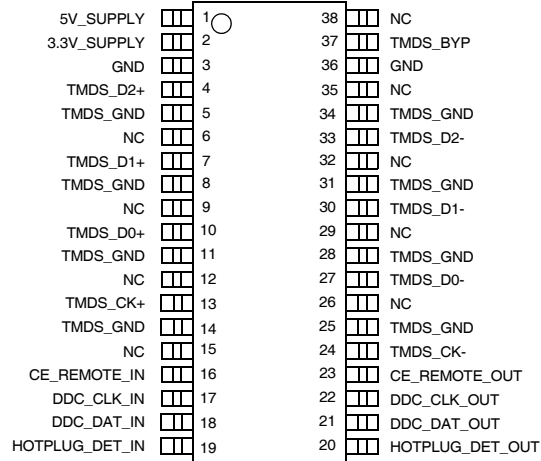

38-PIN TSSOP PACKAGE

Note: This drawing is not to scale.

PIN DESCRIPTIONS

PINS	NAME	DESCRIPTION
37	TMDS_BYP	This input pin is used to connect an optional external 0.1uF ceramic bypass capacitor only to enhance the ESD protection level. Note: Do not connect this pin to GND or any power rail.
4	TMDS_D2+	TMDS 0.9pF ESD protection.
33	TMDS_D2-	TMDS 0.9pF ESD protection.
7	TMDS_D1+	TMDS 0.9pF ESD protection.
30	TMDS_D1-	TMDS 0.9pF ESD protection.
10	TMDS_D0+	TMDS 0.9pF ESD protection.
27	TMDS_D0-	TMDS 0.9pF ESD protection.
13	TMDS_CK+	TMDS 0.9pF ESD protection.
24	TMDS_CK-	TMDS 0.9pF ESD protection.
16	CE_REMOTE_IN	3.3V_SUPPLY referenced logic level in.
23	CE_REMOTE_OUT	5V_SUPPLY referenced logic level out plus 3.5pF ESD.
17	DDC_CLK_IN	3.3V_SUPPLY referenced logic level in.
22	DDC_CLK_OUT	5V_SUPPLY referenced logic level out plus 3.5pF ESD.
18	DDC_DAT_IN	3.3V_SUPPLY referenced logic level in.
21	DDC_DAT_OUT	5V_SUPPLY referenced logic level out plus 3.5pF ESD.
19	HOTPLUG_DET_IN	3.3V_SUPPLY referenced logic level in.
20	HOTPLUG_DET_OUT	5V_SUPPLY referenced logic level out plus 3.5pF ESD.
2	3.3V_SUPPLY	Bias for CE / DDC / HOTPLUG level shifters.
1	5V_SUPPLY	Bias for CE / DDC / HOTPLUG level shifters plus current source for 5V_OUT.
6, 9, 12, 15, 26, 29, 32, 35, 38	NC	No connect.
3, 5, 8, 11, 14, 25, 28, 31, 34, 36	GND / TDMS_GND	GND reference.

Ordering Information

PART NUMBERING INFORMATION					
Pins	Package	Standard Finish		Lead-free Finish	
		Ordering Part Number ¹	Part Marking	Ordering Part Number ¹	Part Marking
38	TSSOP-38	CM2021-00TS	CM2021-00TS	CM2021-00TR	CM2021-00TR

Note 1: Parts are shipped in Tape & Reel form unless otherwise specified.

Specifications

ABSOLUTE MAXIMUM RATINGS		
PARAMETER	RATING	UNITS
V _{CC5} , V _{CC3}	6.0	V
DC Voltage at any Channel Input	[GND - 0.5] to [VCC + 0.5]	V
Storage Temperature Range	-65 to +150	°C
Operating Temperature Range	-40 to +85	°C

STANDARD (RECOMMENDED) OPERATING CONDITIONS					
SYMBOL	PARAMETER	MIN	TYP	MAX	UNITS
5V_SUPPLY	Operating Supply Voltage		5	5.5	V
3V_SUPPLY	Bias Supply Voltage	1	3.3	5.5	V

Specifications (cont'd)

ELECTRICAL OPERATING CHARACTERISTICS						
SYMBOL	PARAMETER	CONDITIONS	MIN	TYP	MAX	UNITS
I_{CC5}	Operating Supply Current	5V_SUPPLY = 5.0V		110	130	μ A
I_{CC3}	Bias Supply Current	3.3V_SUPPLY = 3.3V		1	5	μ A
I_{OFF}	OFF state leakage current, level shifting NFET	3.3V_SUPPLY = 0V		0.1	5	μ A
$I_{BACKDRIVE}$	Current conducted from output pins to V_SUPPLY rails when powered down	5V_SUPPLY < V _{CH_OUT} ; Signal pins: TMDS_[2:0]+/-, TMDS_CK+/-, CE_REMOTE_OUT, DDC_DAT_OUT, DDC_CLK_OUT, HOTPLUG_DET_OUT Only		0.1	5	μ A
V_{ON}	VOLTAGE drop across level shifting NFET when ON	3.3V_SUPPLY = 2.5V, V _S = GND, I _{DS} = 3mA	75	95	140	mV
V_F	Diode Forward Voltage Top Diode Bottom Diode	I _F = 8mA, T _A = 25°C, Note 2	0.6 0.6	0.85 0.85	0.95 0.95	V V
V_{ESD}	ESD Withstand Voltage (IEC)	Pins 4, 7, 10, 13, 20, 21, 22, 23, 24, 27, 30, 33; Notes 2 and 3	\pm 8			kV
V_{ESD}	ESD Withstand Voltage (HBM)	Pins 1, 2, 16, 17, 18, 19, 37; Notes 2 and 4	\pm 2			kV
V_{CL}	Channel Clamp Voltage @ 8kV HBM ESD Positive Transients Negative Transients	T _A = 25°C, Notes 2 and 4		9.0 -9.0		V V
R_{DYN}	Dynamic Resistance Positive Transients Negative Transients	I = 1A, T _A = 25°C, Note 5		3.0 1.5		Ω Ω
I_{LEAK}	TMDS Channel Leakage Current	T _A = 25°C, Note 2		0.01	1	μ A
$C_{IN, TMDS}$	TMDS Channel Input Capacitance	5V_SUPPLY = 5.0V, Measured at 1MHz, V _{BIAS} =2.5V, Note 2		0.9	1.2	pF
$\Delta C_{IN, TMDS}$	C _{IN} Matching Capacitance	5V_SUPPLY = 5.0V, Measured at 1MHz, V _{BIAS} =2.5V, Note 2, 6		0.05		pF
C_{MUTUAL}	Mutual Capacitance between signal pin and NC pin	5V_SUPPLY= 0V, Measured at 1MHz, V _{BIAS} =2.5V, Note 2		0.07		pF
$C_{IN, DDC}$	Level Shifting Input Capacitance, Capacitance to GND	5V_SUPPLY = 0V, Measured at 100KHz, V _{BIAS} =2.5V, Note 2		3.5	4	pF

ELECTRICAL OPERATING CHARACTERISTICS

$C_{IN, CEC}$	Level Shifting Input Capacitance, Capacitance to GND	5V_SUPPLY = 0V, Measured at 100KHz, $V_{BIAS}=2.5V$, Note 2		3.5	4	pF
$C_{IN, HP}$	Level Shifting Input Capacitance, Capacitance to GND	5V_SUPPLY = 0V, Measured at 100KHz, $V_{BIAS}=2.5V$, Note 2		3.5	4	pF

Note 1: Operating Characteristics are over Standard Operating Conditions unless otherwise specified.

Note 2: This parameter is guaranteed by design and verified by device characterization.

Note 3: Standard IEC 61000-4-2, $C_{DISCHARGE}=150pF$, $R_{DISCHARGE}=330\Omega$

Note 4: Human Body Model per MIL-STD-883, Method 3015, $C_{DISCHARGE}=100pF$, $R_{DISCHARGE}=1.5k\Omega$

Note 5: These measurements performed with no external capacitor on TMD5_BYP.

Note 6: Intra-pair matching, each TMD5 pair (i.e. D+, D-)

Performance Information

Typical Filter Performance (T_A=25°C, DC Bias=0V, 50 Ohm Environment)

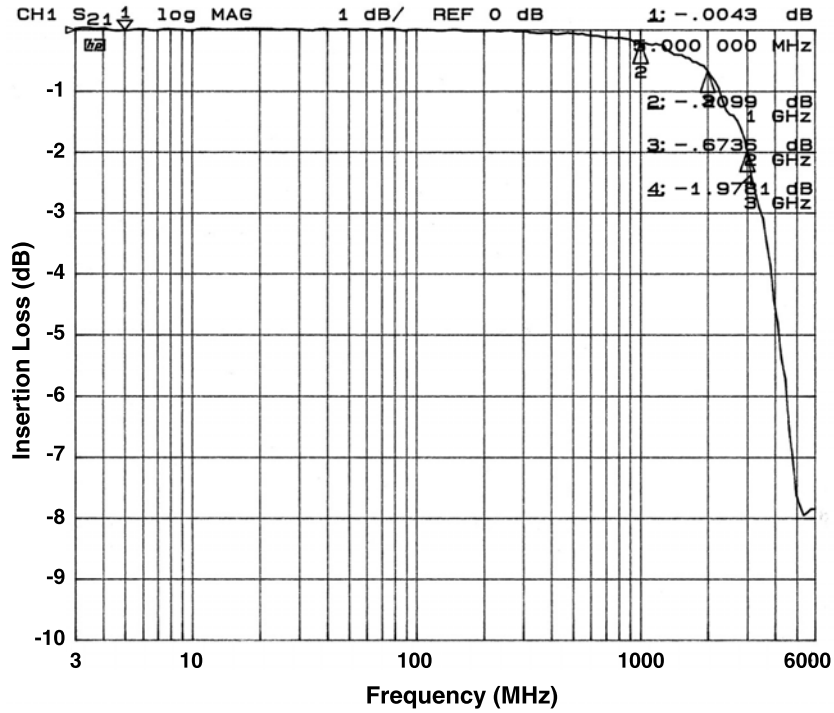

Figure 1. Insertion Loss vs. Frequency (TMDS_D1- to GND)

Application Information

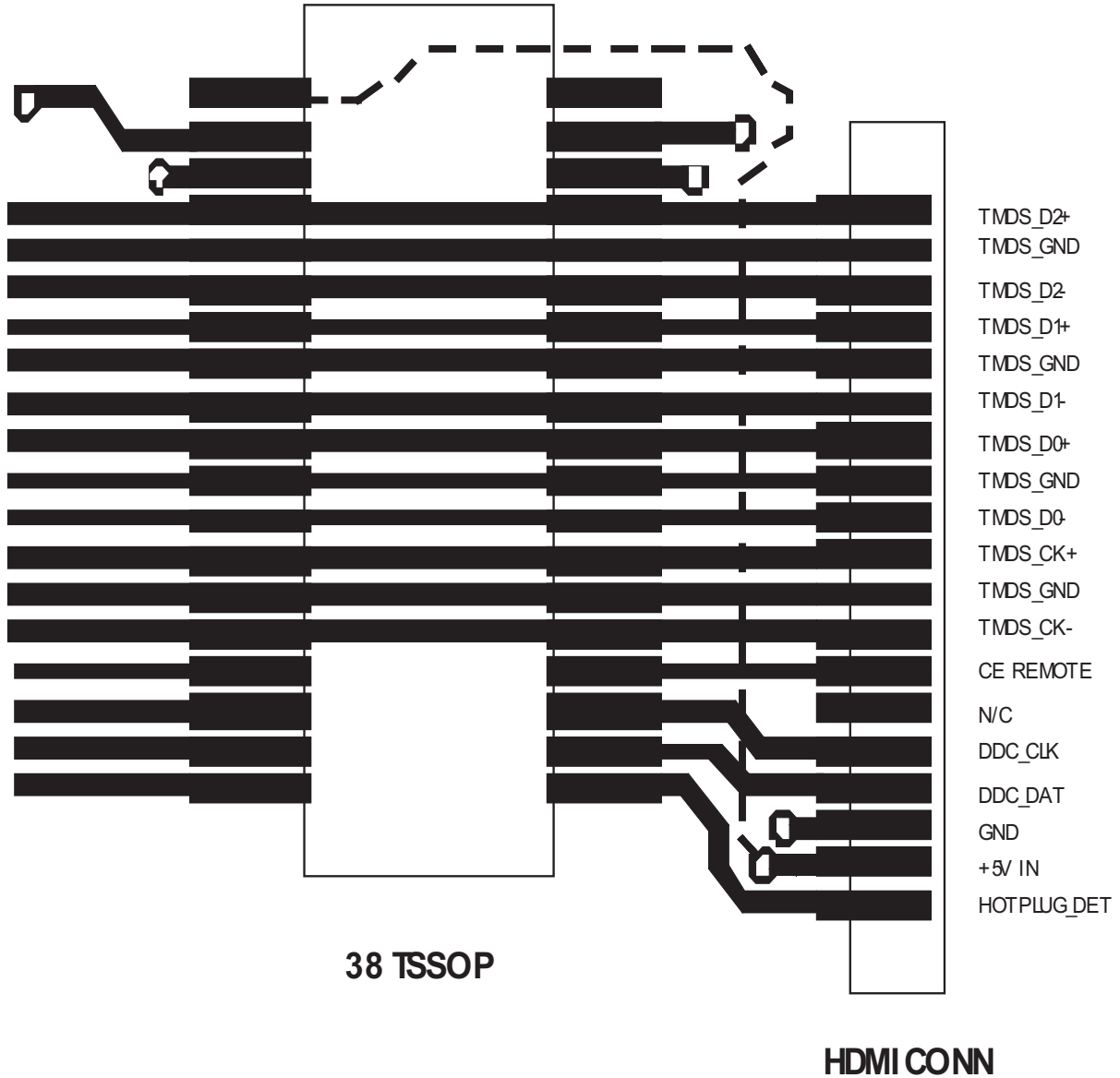

Figure 2. Typical Application for CM2021

Mechanical Details

TSSOP-38 Mechanical Specifications

CM2021 devices are supplied in 38-pin TSSOP packages. Dimensions are presented below.

For complete information on the TSSOP-38, see the California Micro Devices TSSOP Package Information document.

PACKAGE DIMENSIONS				
Package	TSSOP			
JEDEC No.	MO-153 (Variation BD-1)			
Pins	38			
Dimensions	Millimeters		Inches	
	Min	Max	Min	Max
A	—	1.20	—	0.047
A1	0.05	0.15	0.002	0.006
b	0.17	0.27	0.007	0.011
c	0.09	0.20	0.004	0.008
D	9.60	9.80	0.378	0.386
E	6.40 BSC		0.252 BSC	
E1	4.30	4.50	0.169	0.177
e	0.50 BSC		0.020 BSC	
L	0.45	0.75	0.018	0.030
# per tape and reel	2500 pieces			
Controlling dimension: millimeters				

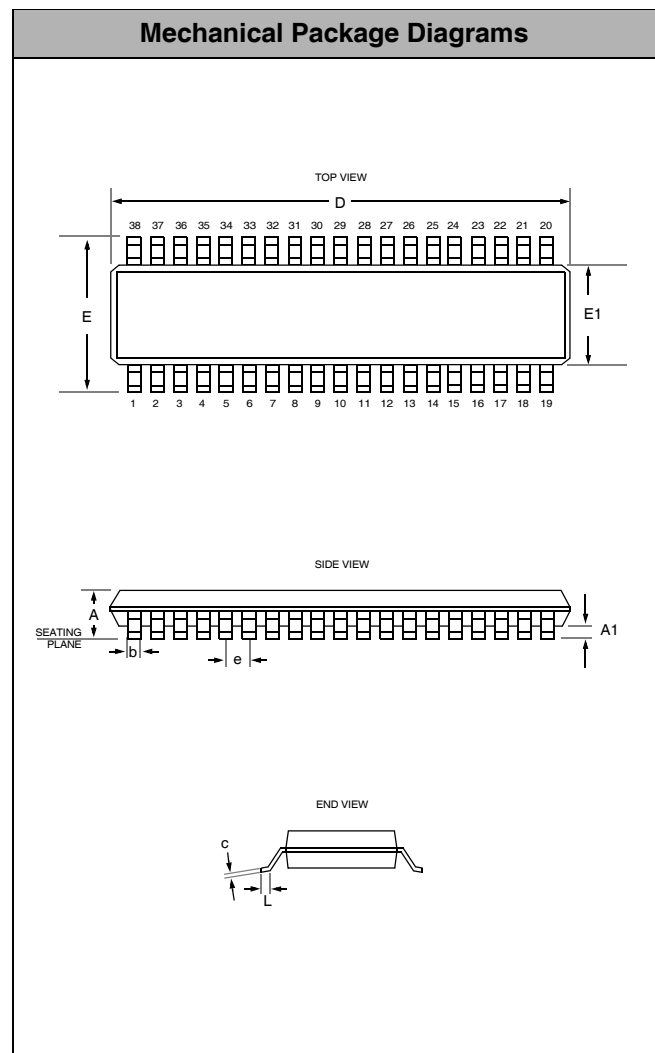

Package Dimensions for TSSOP-38