



8-bit I²C and SMBus I/O Port with Interrupt

FEATURES

- 400kHz I²C bus compatible
- 2.3V to 5.5V operation
- Low stand-by current
- 5V tolerant I/Os
- 8 I/O pins that default to inputs at power-up
- High drive capability
- Individual I/O configuration
- Polarity inversion register
- Active low interrupt output
- Internal power-on reset
- No glitch on power-up
- Noise filter on SDA/SCL inputs
- Cascadable up to 8 devices
- Industrial temperature range
- RoHS-compliant 16-lead SOIC and TSSOP, and 16-pad TQFN (4 x 4mm) packages

APPLICATIONS

- White goods (dishwashers, washing machines)
- Handheld devices (cell phones, PDAs, digital cameras)
- Data Communications (routers, hubs and servers)

BLOCK DIAGRAM ⁽¹⁾

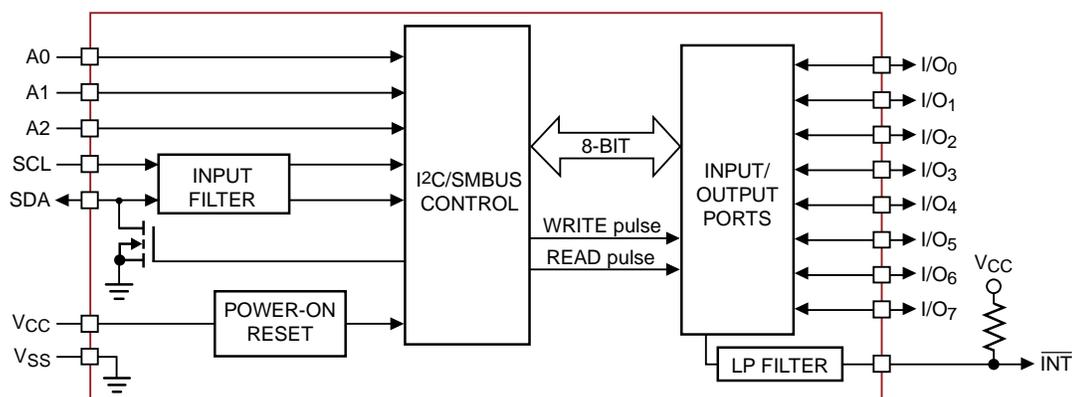

Notes:

(1) All I/Os are set to inputs at RESET.

DESCRIPTION

The CAT9534 is an 8-bit parallel input/output port expander for I²C and SMBus compatible applications. These I/O expanders provide a simple solution in applications where additional I/Os are needed: sensors, power switches, LEDs, pushbuttons, and fans.

The CAT9534 consists of an input port register, an output port register, a configuration register, a polarity inversion register and an I²C/SMBus-compatible serial interface.

Any of the eight I/Os can be configured as an input or output by writing to the configuration register. The system master can invert the CAT9534 input data by writing to the active-high polarity inversion register.

The CAT9534 features an active low interrupt output which indicates to the system master that an input state has changed.

The device's extended addressing capability allows up to 8 devices to share the same bus.

CAT9534 is offered in 16 pin SOIC, TSSOP and TQFN packages and operates over the full -40°C to +85°C industrial temperature range.

For Ordering Information details, see page 15.

PIN CONFIGURATION

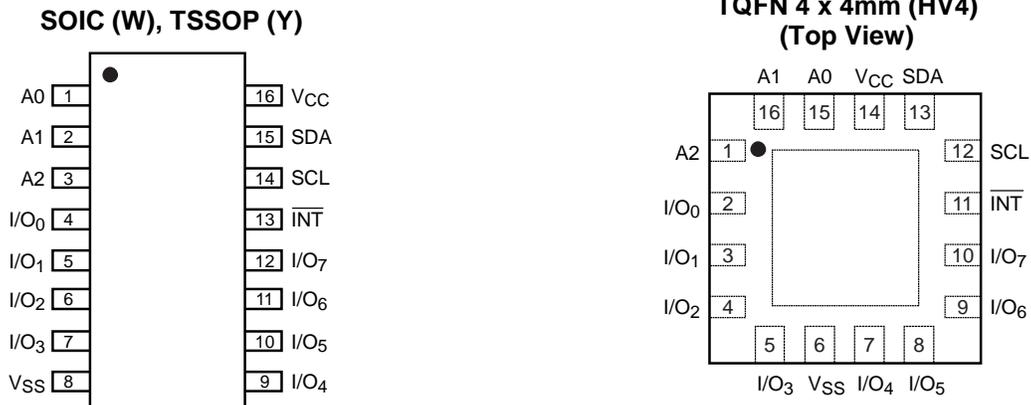

PIN DESCRIPTION

SOIC / TSSOP	TQFN	Pin Name	Function
1	15	A0	Address Input 0
2	16	A1	Address Input 1
3	1	A2	Address Input 2
4-7	2-5	I/O ₀₋₃	Input/Output Port 0 to Input/Output Port 3
8	6	V _{SS}	Ground
9-12	7-10	I/O ₄₋₇	Input/Output Port 4 to Input/Output Port 7
13	11	INT	Interrupt Output (open drain)
14	12	SCL	Serial Clock
15	13	SDA	Serial Data
16	14	V _{CC}	Power Supply

ABSOLUTE MAXIMUM RATINGS ⁽¹⁾

Parameters	Ratings	Units
V _{CC} with Respect to Ground	-0.5 to +6.5	V
Voltage on Any Pin with Respect to Ground	-0.5 to +5.5	V
DC Current on I/O ₀ to I/O ₇	±50	mA
DC Input Current	±20	mA
V _{CC} Supply Current	85	mA
V _{SS} Supply Current	100	mA
Package Power Dissipation Capability (T _A = 25°C)	1.0	W
Junction Temperature	+150	°C
Storage Temperature	-65 to +150	°C

RELIABILITY CHARACTERISTICS

Symbol	Parameter	Reference Test Method	Min	Units
V _{ZAP} ⁽²⁾	ESD Susceptibility	JEDEC Standard JESD 22	2000	Volts
I _{LTH} ⁽²⁾⁽³⁾	Latch-up	JEDEC Standard 17	100	mA

Notes:

- (1) Stresses above those listed under "Absolute Maximum Ratings" may cause permanent damage to the device. These are stress ratings only, and functional operation of the device at these or any other conditions outside of those listed in the operational sections of this specification is not implied. Exposure to any absolute maximum rating for extended periods may affect device performance and reliability.
- (2) This parameter is tested initially and after a design or process change that affects the parameter.
- (3) Latch-up protection is provided for stresses up to 100mA on address and data pins from -1V to V_{CC} +1V.

D.C. OPERATING CHARACTERISTICS

$V_{CC} = 2.3$ to $5.5V$; $T_A = -40^{\circ}C$ to $+85^{\circ}C$, unless otherwise specified.

Symbol	Parameter	Conditions	Min	Typ	Max	Unit
Supplies						
V_{CC}	Supply voltage		2.3	—	5.5	V
I_{CC}	Supply current	Operating mode; $V_{CC} = 5.5V$; no load; $f_{SCL} = 100kHz$	—	104	175	μA
I_{stbl}	Standby current	Standby mode; $V_{CC} = 5.5V$; no load; $V_I = V_{SS}$; $f_{SCL} = 0kHz$; I/O = inputs	—	0.25	3	μA
I_{stbh}	Standby current	Standby mode; $V_{CC} = 5.5V$; no load; $V_I = V_{CC}$; $f_{SCL} = 0kHz$; I/O = inputs	—	0.25	1	μA
V_{POR}	Power-on reset voltage	No load; $V_I = V_{CC}$ or V_{SS}	—	1.5	1.65	V
SCL, SDA, INT						
$V_{IL}^{(1)}$	Low level input voltage		-0.5	—	$0.3 \times V_{CC}$	V
$V_{IH}^{(1)}$	High level input voltage		$0.7 \times V_{CC}$	—	5.5	V
I_{OL}	Low level output current	$V_{OL} = 0.4V$	3	—	—	mA
I_L	Leakage current	$V_I = V_{CC}$ or V_{SS}	-1	—	+1	μA
$C_I^{(2)}$	Input capacitance	$V_I = V_{SS}$	—	—	6	pF
$C_O^{(2)}$	Output capacitance	$V_O = V_{SS}$	—	—	8	pF
A0, A1, A2						
$V_{IL}^{(1)}$	Low level input voltage		-0.5	—	0.8	V
$V_{IH}^{(1)}$	High level input voltage		2.0	—	5.5	V
I_{LI}	Input leakage current		-1	—	1	μA
I/Os						
V_{IL}	Low level input voltage		-0.5	—	0.8	V
V_{IH}	High level input voltage		2.0	—	5.5	V
I_{OL}	Low level output current	$V_{OL} = 0.5V$; $V_{CC} = 2.3V^{(3)}$	8	10	—	mA
		$V_{OL} = 0.7V$; $V_{CC} = 2.3V^{(3)}$	10	13	—	mA
		$V_{OL} = 0.5V$; $V_{CC} = 4.5V^{(3)}$	8	17	—	mA
		$V_{OL} = 0.7V$; $V_{CC} = 4.5V^{(3)}$	10	24	—	mA
		$V_{OL} = 0.5V$; $V_{CC} = 3.0V^{(3)}$	8	14	—	mA
		$V_{OL} = 0.7V$; $V_{CC} = 3.0V^{(3)}$	10	19	—	mA
V_{OH}	High level output voltage	$I_{OH} = -8mA$; $V_{CC} = 2.3V^{(4)}$	1.8	—	—	V
		$I_{OH} = -10mA$; $V_{CC} = 2.3V^{(4)}$	1.7	—	—	V
		$I_{OH} = -8mA$; $V_{CC} = 3.0V^{(4)}$	2.6	—	—	V
		$I_{OH} = -10mA$; $V_{CC} = 3.0V^{(4)}$	2.5	—	—	V
		$I_{OH} = -8mA$; $V_{CC} = 4.75V^{(4)}$	4.1	—	—	V
		$I_{OH} = -10mA$; $V_{CC} = 4.75V^{(4)}$	4.0	—	—	V
I_L	Input leakage current	$V_{CC} = 3.6V$; $V_I = V_{CC}$	—	—	1	μA
$C_I^{(2)}$	Input capacitance		—	—	5	pF
$C_O^{(2)}$	Output capacitance		—	—	8	pF

Notes:

- (1) $V_{IL\ min}$ and $V_{IH\ max}$ are reference values only and are not tested.
- (2) This parameter is characterized initially and after a design or process change that affects the parameter. Not 100% tested.
- (3) The total current sunk by all I/Os must be limited to 100mA and each I/O limited to 25mA maximum.
- (4) The total current sourced by all I/Os must be limited to 85mA.

A.C. CHARACTERISTICS

$V_{CC} = 2.3$ to $5.5V$; $T_A = -40^{\circ}C$ to $+85^{\circ}C$, unless otherwise specified. ⁽¹⁾

Symbol	Parameter	Standard I ² C		Fast I ² C		Units
		Min	Max	Min	Max	
F_{SCL}	Clock Frequency		100		400	kHz
$t_{HD:STA}$	START Condition Hold Time	4		0.6		μs
t_{LOW}	Low Period of SCL Clock	4.7		1.3		μs
t_{HIGH}	High Period of SCL Clock	4		0.6		μs
$t_{SU:STA}$	START Condition Setup Time	4.7		0.6		μs
$t_{HD:DAT}$	Data In Hold Time	0		0		μs
$t_{SU:DAT}$	Data In Setup Time	250		100		ns
$t_R^{(2)}$	SDA and SCL Rise Time		1000		300	ns
$t_F^{(2)}$	SDA and SCL Fall Time		300		300	ns
$t_{SU:STO}$	STOP Condition Setup Time	4		0.6		μs
$t_{BUF}^{(2)}$	Bus Free Time Between STOP and START	4.7		1.3		μs
t_{AA}	SCL Low to Data Out Valid		3.5		0.9	μs
t_{DH}	Data Out Hold Time	100		50		ns
$T_i^{(2)}$	Noise Pulse Filtered at SCL and SDA Inputs		100		100	ns

Symbol	Parameter	Min	Max	Units
Port Timing				
t_{PV}	Output Data Valid		200	ns
t_{PS}	Input Data Setup Time	100		ns
t_{PH}	Input Data Hold Time	1		μs
Interrupt Timing				
t_{IV}	Interrupt Valid		4	μs
t_{IR}	Interrupt Reset		4	μs

Notes:

(1) Test conditions according to "AC Test Conditions" table.

(2) This parameter is characterized initially and after a design or process change that affects the parameter. Not 100% tested.

A.C. TEST CONDITIONS

Input Rise and Fall time	$\leq 10\text{ns}$
CMOS Input Voltages	$0.2V_{CC}$ to $0.8V_{CC}$
CMOS Input Reference Voltages	$0.3V_{CC}$ to $0.7V_{CC}$
TTL Input Voltages	$0.4V$ to $2.4V$
TTL Input Reference Voltages	$0.8V$, $2.0V$
Output Reference Voltages	$0.5V_{CC}$
Output Load: SDA, INT	Current Source $I_{OL} = 3\text{mA}$; $C_L = 100\text{pF}$
Output Load: I/Os	Current Source: $I_{OL}/I_{OH} = 10\text{mA}$; $C_L = 50\text{pF}$

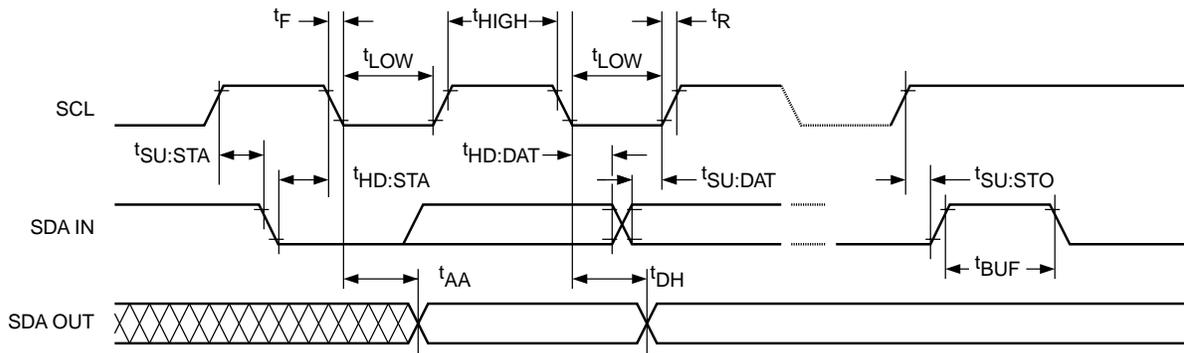

Figure 1. I²C Serial Interface Timing

PIN DESCRIPTION

SCL: Serial Clock

The serial clock input clocks all data transferred into or out of the device. The SCL line requires a pull-up resistor if it is driven by an open drain output.

SDA: Serial Data/Address

The bidirectional serial data/address pin is used to transfer all data into and out of the device. The SDA pin is an open drain output and can be wire-ORed with other open drain or open collector outputs. A pull-up resistor must be connected from SDA line to V_{CC} . The value of the pull-up resistor, R_P , can be calculated based on minimum and maximum values from Figure 2 and Figure 3 (see Note).

A0, A1, A2: Device Address Inputs

These inputs are used for extended addressing capability. The A0, A1, A2 pins should be hardwired to V_{CC} or V_{SS} . When hardwired, up to eight CAT9534s may be addressed on a single bus system. The levels on these inputs are compared with corresponding bits, A2, A1, A0, from the slave address byte.

I/O₀ to I/O₇: Input / Output Ports

Any of these pins may be configured as input or output. The simplified schematic of I/O₀ to I/O₇ is shown in Figure 4. When an I/O is configured as an input, the Q1 and Q2 output transistors are off creating a high impedance input. If the I/O pin is configured as an output, the push-pull output stage is enabled. Care should be taken if an external voltage is applied to an I/O pin configured as an output due to the low impedance paths that exist between the pin and either V_{CC} or V_{SS} .

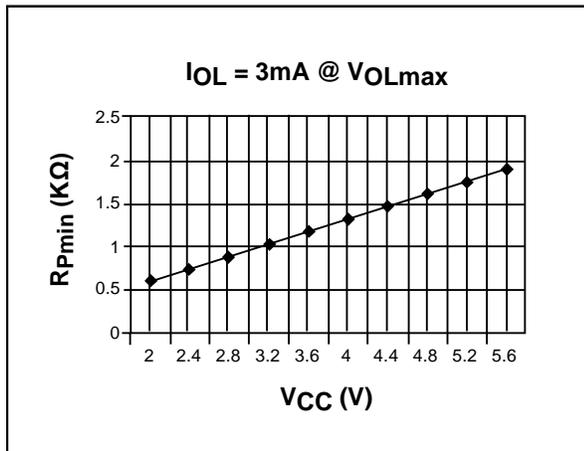

Figure 2. Minimum R_P Value versus Supply Voltage

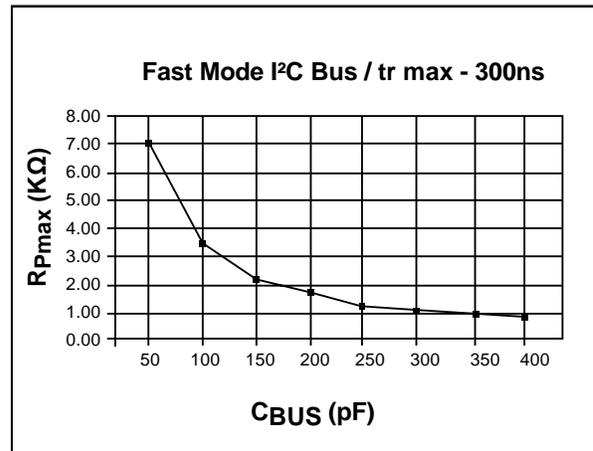

Figure 3. Maximum R_P Value versus Bus Capacitance

Note: According to the Fast Mode I²C bus specification, for bus capacitance up to 200pF, the pull up device can be a resistor. For bus loads between 200pF and 400pF, the pull-up device can be a current source ($I_{max} = 3mA$) or a switched resistor circuit.

INT: Interrupt Output

The open-drain interrupt output is activated when one of the port pins configured as an input changes state (differs from the corresponding input port register bit state). The interrupt is deactivated when the input

returns to its previous state or the input port register is read. Changing an I/O from an output to an input may cause a false interrupt if the state of the pin does not match the contents of the input port register.

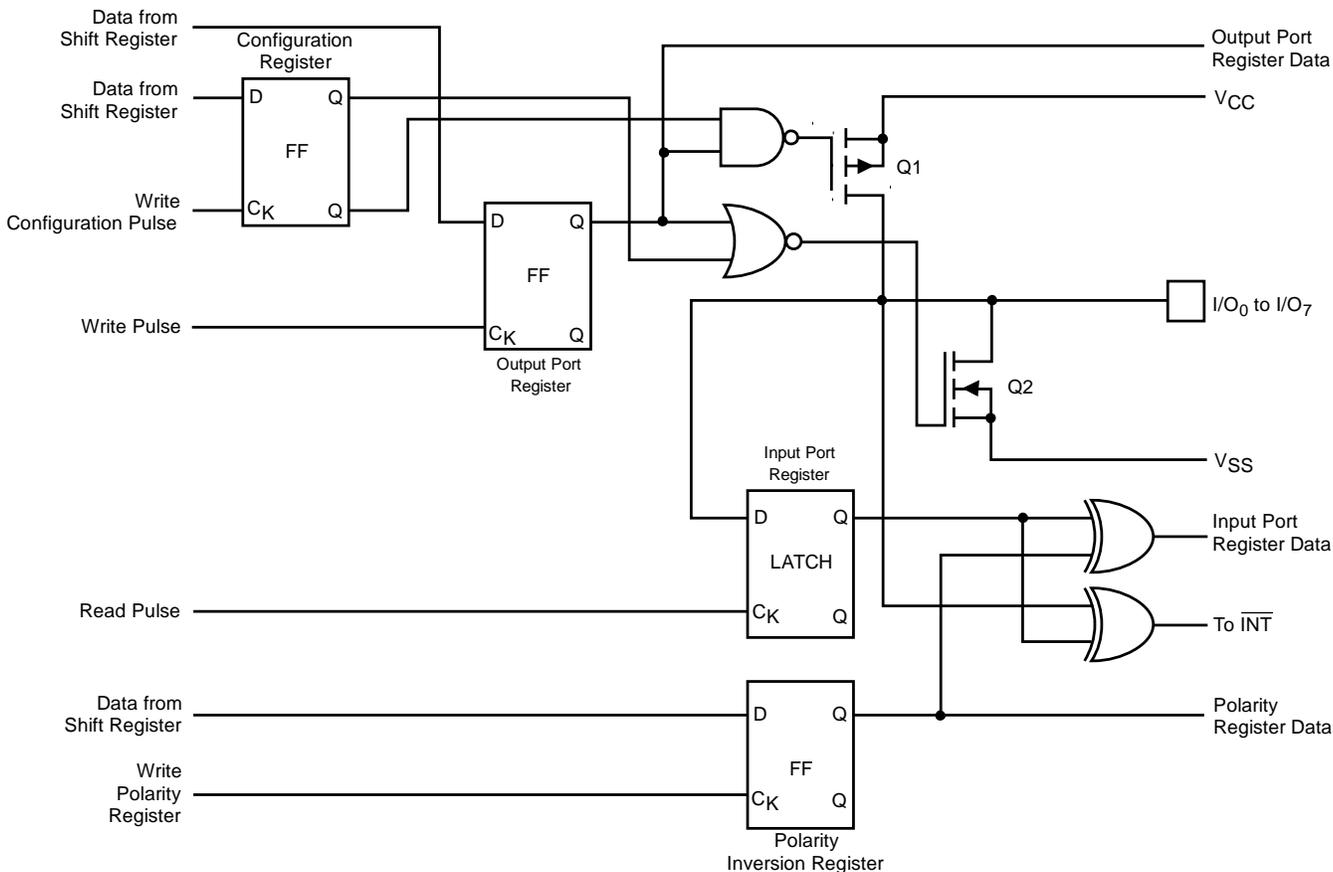

Figure 4. Simplified Schematic of I/O₀ to I/O₇

FUNCTIONAL DESCRIPTION

CAT9534's general purpose input/ output (GPIO) peripherals provide up to eight I/O ports, controlled through an I²C compatible serial interface

The CAT9534 supports the I²C Bus data transmission protocol. This I²C Bus protocol defines any device that sends data to the bus to be a transmitter and any device receiving data to be a receiver. The transfer is controlled by the Master device which generates the serial clock and all START and STOP conditions for bus access. The CAT9534 operates as a Slave device. Both the Master device and Slave device can operate as either transmitter or receiver, but the Master device controls which mode is activated.

I²C BUS PROTOCOL

The features of the I²C bus protocol are defined as follows:

- (1) Data transfer may be initiated only when the bus is not busy.
- (2) During a data transfer, the data line must remain stable whenever the clock line is high. Any changes in the data line while the clock line is high will be interpreted as a START or STOP condition (Figure 5).

START AND STOP CONDITIONS

The START Condition precedes all commands to the device, and is defined as a HIGH to LOW transition of

SDA when SCL is HIGH. The CAT9534 monitors the SDA and SCL lines and will not respond until this condition is met.

A LOW to HIGH transition of SDA when SCL is HIGH determines the STOP condition. All operations must end with a STOP condition.

DEVICE ADDRESSING

After the bus Master sends a START condition, a slave address byte is required to enable the CAT9534 for a read or write operation. The four most significant bits of the slave address are fixed as binary 0100 and the next three bits are its individual address bits (Figure 6).

The address bits A2, A1 and A0 are used to select which device is accessed from maximum eight devices on the same bus. These bits must compare to their hardwired input pins. The 8th bit following the 7-bit slave address is the R/W bit that specifies whether a read or write operation is to be performed. When this bit is set to "1", a read operation is initiated, and when set to "0", a write operation is selected.

Following the START condition and the slave address byte, the CAT9534 monitors the bus and responds with an acknowledge (on the SDA line) when its address matches the transmitted slave address. The CAT9534 then performs a read or a write operation depending on the state of the R/W bit.

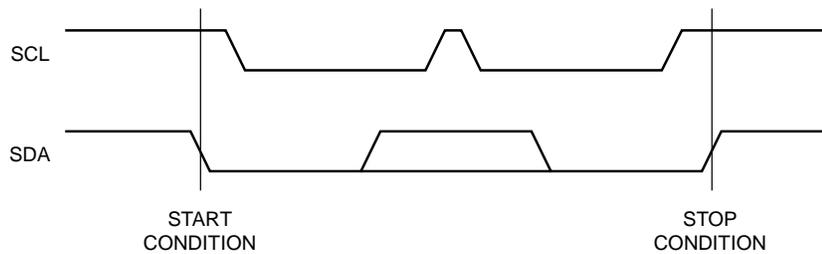

Figure 5. START/STOP Condition

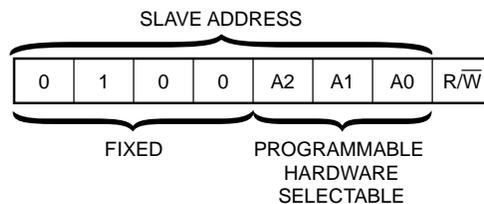

Figure 6. CAT9534 Slave Address

ACKNOWLEDGE

After a successful data transfer, each receiving device is required to generate an acknowledge. The acknowledging device pulls down the SDA line during the ninth clock cycle, signaling that it received the 8 bits of data. The SDA line remains stable LOW during the HIGH period of the acknowledge related clock pulse (Figure 5).

The CAT9534 responds with an acknowledge after receiving a START condition and its slave address. If the device has been selected along with a write operation, it responds with an acknowledge after receiving each 8-bit byte.

When the CAT9534 begins a READ mode it transmits 8 bits of data, releases the SDA line, and monitors the line for an acknowledge. Once it receives this acknowledge, the CAT9534 will continue to transmit data. If no acknowledge is sent by the Master, the device terminates data transmission and waits for a STOP condition. The master must then issue a STOP condition to return the CAT9534 to the standby power mode and place the device in a known state.

REGISTERS AND BUS TRANSACTIONS

The CAT9534 consists of an input port register, an output port register, a polarity inversion register and a configuration register. Table 1 shows the register address table. Tables 2 to 5 list Register 0 through Register 3 information.

Table 1. Register Command Byte

Command (hex)	Protocol	Function
0x00	Read byte	Input port register
0x01	Read/write byte	Output port register
0x02	Read/write byte	Polarity inversion register
0x03	Read/write byte	Configuration register

The command byte is the first byte to follow the device address byte during a write/read bus transaction. The register command byte acts as a pointer to determine which register will be written or read.

The input port register is a read only port. It reflects the incoming logic levels of the I/O pins, regardless of whether the pin is defined as an input or an output by the configuration register. Writes to the input port register are ignored.

Table 2. Register 0 – Input Port Register

bit	I ₇	I ₆	I ₅	I ₄	I ₃	I ₂	I ₁	I ₀
default	1	1	1	1	1	1	1	1

Table 3. Register 1 – Output Port Register

bit	O ₇	O ₆	O ₅	O ₄	O ₃	O ₂	O ₁	O ₀
default	1	1	1	1	1	1	1	1

Table 4. Register 2 – Polarity Inversion Register

bit	N ₇	N ₆	N ₅	N ₄	N ₃	N ₂	N ₁	N ₀
default	0	0	0	0	0	0	0	0

Table 5. Register 3 – Configuration Register

bit	C ₇	C ₆	C ₅	C ₄	C ₃	C ₂	C ₁	C ₀
default	1	1	1	1	1	1	1	1

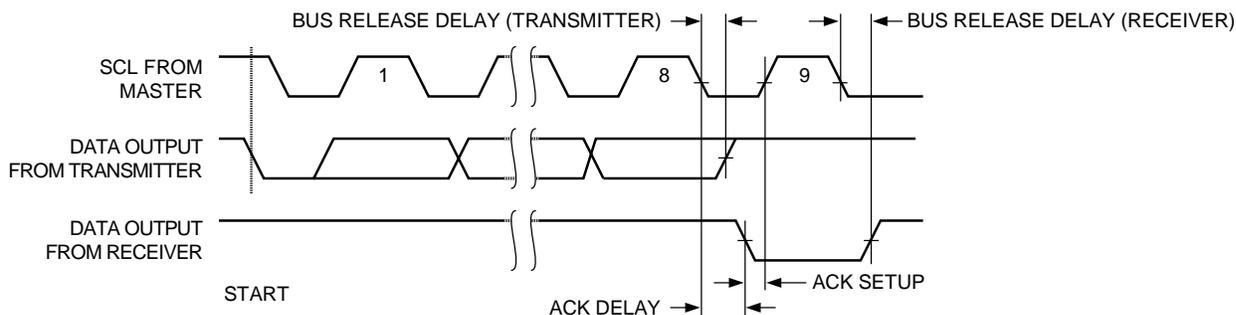

Figure 7. Acknowledge Timing

The output port register sets the outgoing logic levels of the I/O ports, defined as outputs by the configuration register. Bit values in this register have no effect on I/O pins defined as inputs. Reads from the output port register reflect the value that is in the flip-flop controlling the output, not the actual I/O pin value.

The polarity inversion register allows the user to invert the polarity of the input port register data. If a bit in this register is set ("1") the corresponding input port data is inverted. If a bit in the polarity inversion register is cleared ("0"), the original input port polarity is retained.

The configuration register sets the directions of the ports. Set the bit in the configuration register to enable

the corresponding port pin as an input with a high impedance output driver. If a bit in this register is cleared, the corresponding port pin is enabled as an output. At power-up, the I/Os are configured as inputs with a weak pull-up resistor to V_{CC} .

Data is transmitted to the CAT9534's registers using the write mode shown in Figure 8 and Figure 9.

The CAT9534's registers are read according to the timing diagrams shown in Figure 10 and Figure 11. Once a command byte has been sent, the register which was addressed will continue to be accessed by reads until a new command byte will be sent.

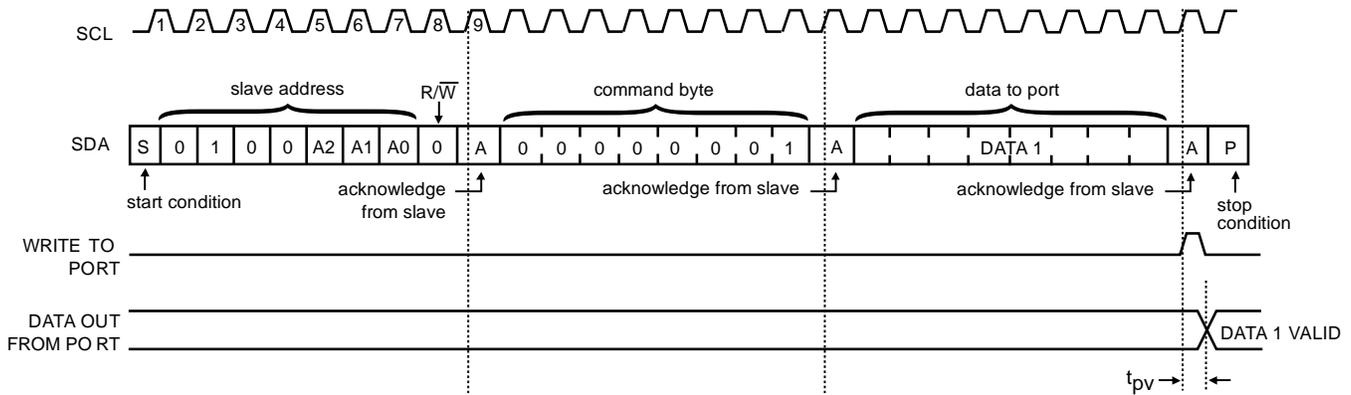

Figure 8. Write to Output Port Register

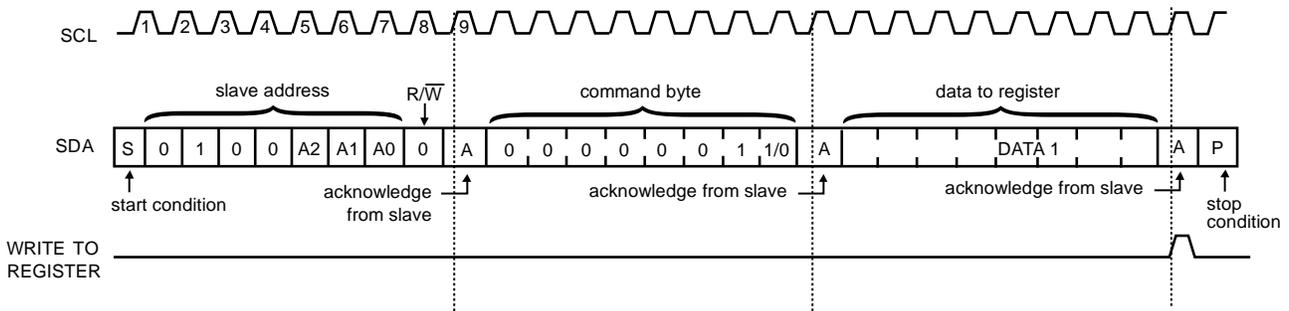

Figure 9. Write to Configuration or Polarity Inversion Register

INTERRUPT OUTPUT

CAT9534's interrupt output is an active LOW open-drain output that is activated when any port pin configured as an input changes state. The interrupt output is reset when the input returns to its previous state or the Input Port Register is read.

Note that changing an I/O from an output to an input may cause a false interrupt to occur if the state of the pin does not match the contents of the Input Port register.

POWER-ON RESET OPERATION

When the power supply is applied to V_{CC} pin, an internal power-on reset pulse holds the CAT9534 in a reset state until V_{CC} reaches V_{POR} level. At this point, the reset condition is released and the internal state machine and the CAT9534's registers are initialized to their default state.

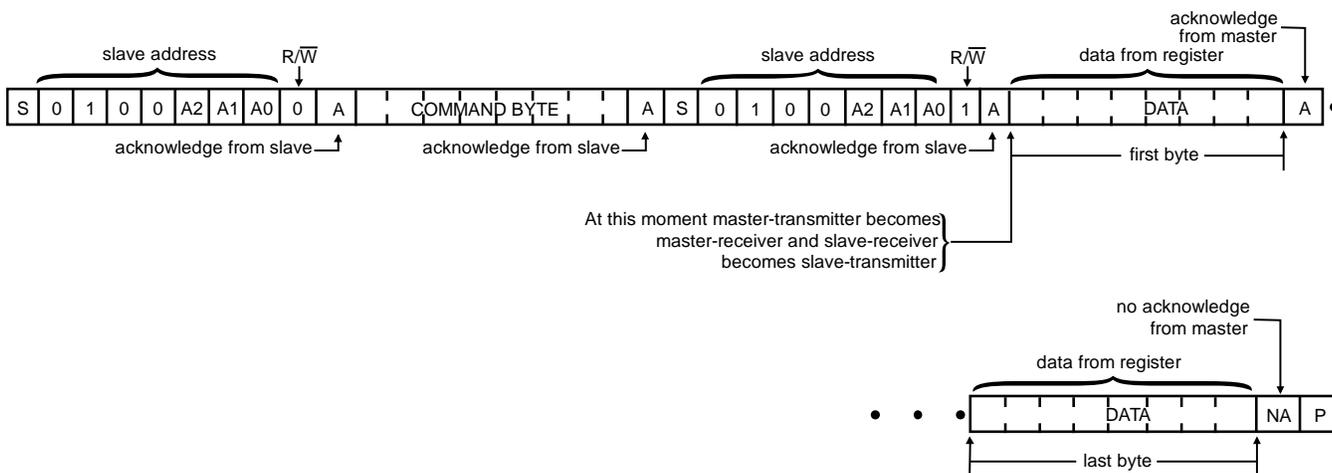

Figure 10. Read from Register

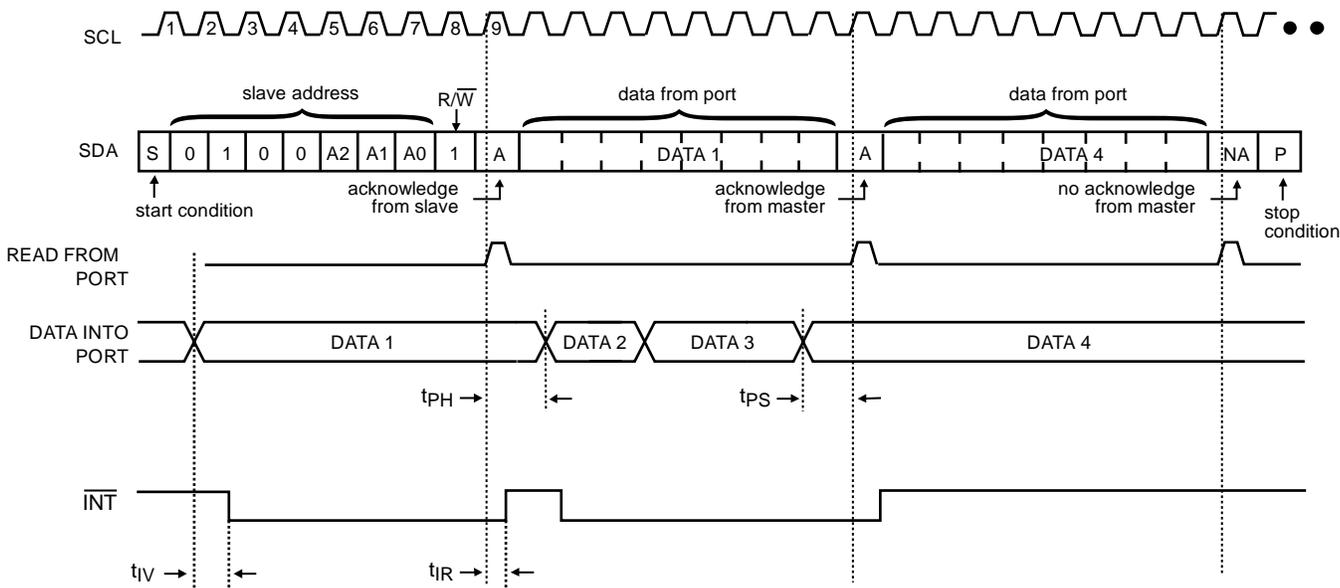
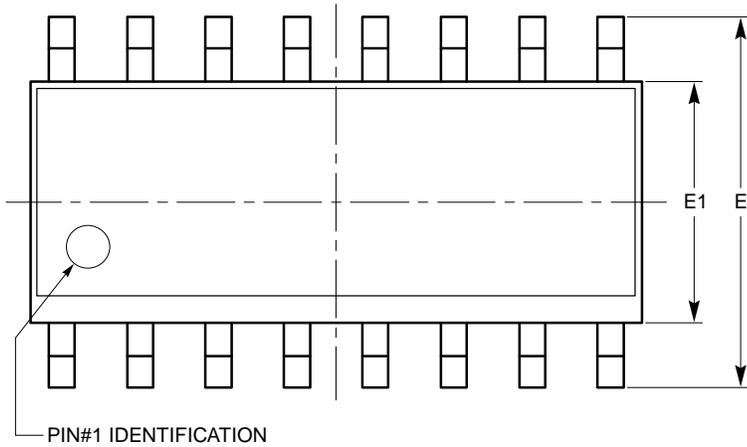

Figure 11. Read Input Port Register

PACKAGE OUTLINE DRAWINGS

SOIC 16-Lead 150mils (W) ⁽¹⁾ ⁽²⁾



TOP VIEW

SYMBOL	MIN	NOM	MAX
A	1.35		1.75
A1	0.10		0.25
b	0.33		0.51
c	0.19		0.25
D	9.80	9.90	10.00
E	5.80	6.00	6.20
E1	3.80	3.90	4.00
e	1.27 BSC		
h	0.25		0.50
L	0.40		1.27
θ	0°		8°

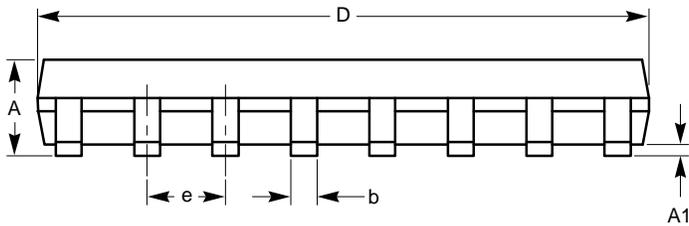

SIDE VIEW

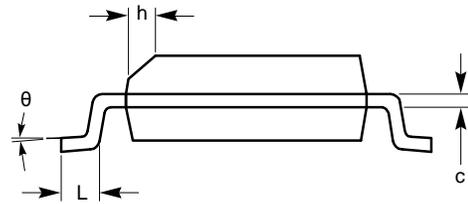

END VIEW

Notes:

- (1) All dimensions are in millimeters. Angles in degrees.
- (2) Complies with JEDEC standard MS-012

TSSOP 16-Lead 4.4mm (Y) ^{(1) (2)}

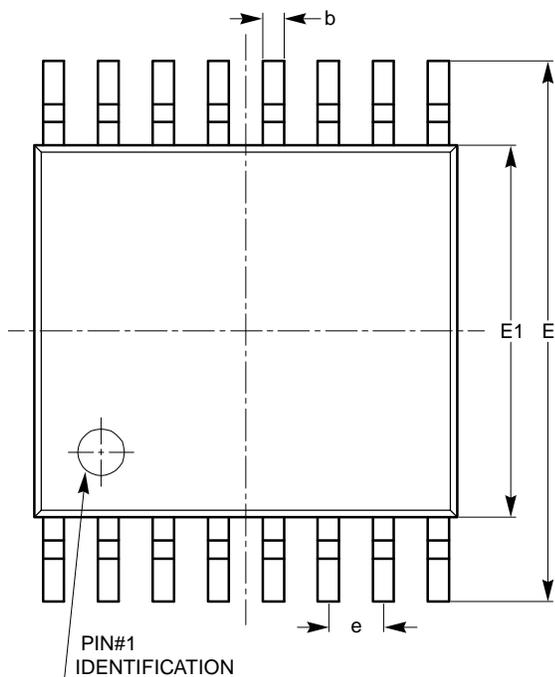

TOP VIEW

SYMBOL	MIN	NOM	MAX
A			1.10
A1	0.05		0.15
A2	0.85		0.95
b	0.19		0.30
c	0.13		0.20
D	4.90		5.10
E	6.30		6.50
E1	4.30		4.50
e	0.65 BSC		
L	1.00 REF		
L1	0.45		0.75
$\theta 1$	0°		8°

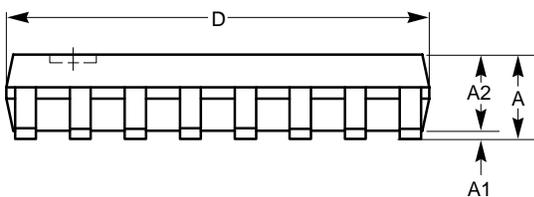

SIDE VIEW

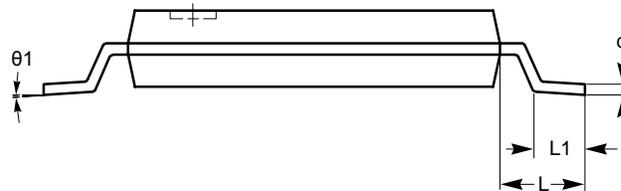

END VIEW

Notes:

- (1) All dimensions are in millimeters. Angles in degrees.
- (2) Complies with JEDEC standard MO-153.

TQFN 16-Pad 4 x 4mm (HV4) ⁽¹⁾ ⁽²⁾

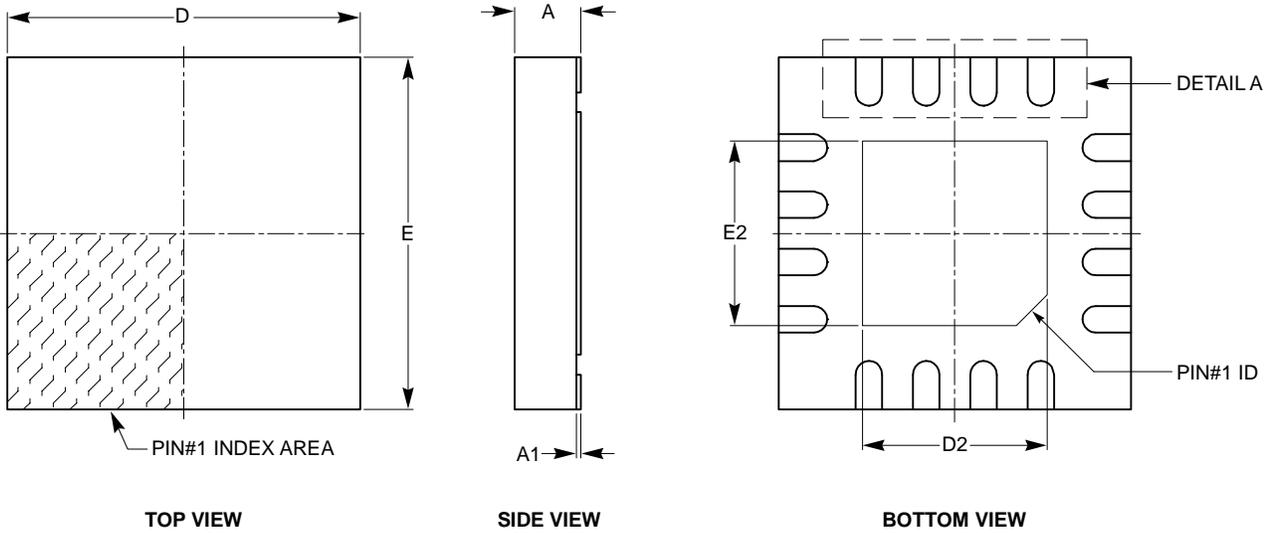

SYMBOL	MIN	NOM	MAX
A	0.70	0.75	0.80
A1	0.00	0.02	0.05
A3	0.20 REF		
b	0.25	0.30	0.35
D	3.90	4.00	4.10
D2	2.00	-	2.25
E	3.90	4.00	4.10
E2	2.00	-	2.25
e	0.65 BSC		
L	0.45	-	0.65

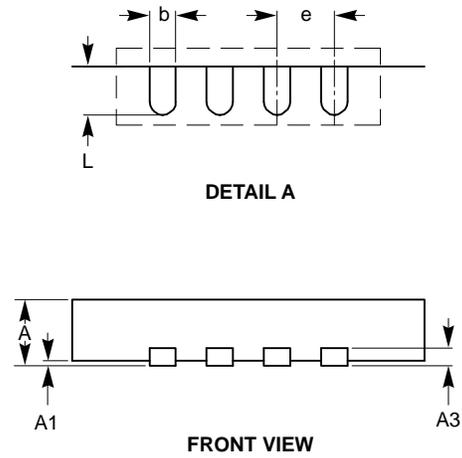

Notes:

- (1) All dimensions are in millimeters.
- (2) Refer to JEDEC standard MO-220.

EXAMPLE OF ORDERING INFORMATION

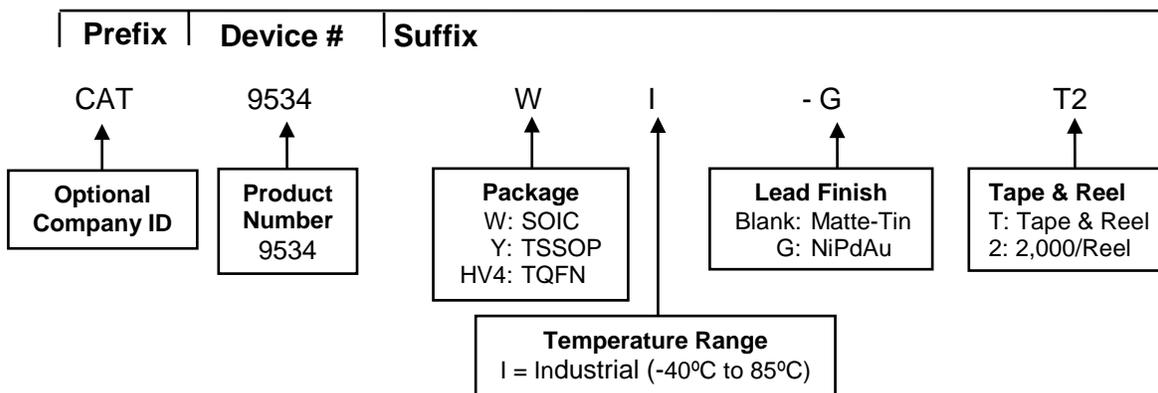

ORDERING PART NUMBER

Part Number	Package	Lead Finish
CAT9534WI-GT2	SOIC	NiPdAu
CAT9534YI-GT2	TSSOP	NiPdAu
CAT9534HV4I-GT2	TQFN	NiPdAu

Notes:

- (1) All packages are RoHS-compliant (Lead-free, Halogen-free).
- (2) The standard lead finish is NiPdAu.
- (3) The device used in the above example is a CAT9534WI-GT2 (SOIC, Industrial Temperature, NiPdAu, Tape & Reel, 2,000/Reel).
- (4) For additional package and temperature options, please contact your nearest ON Semiconductor Sales office.

REVISION HISTORY

Date	Revisio	Description
23-May-08	A	Initial Issue
03-Dec-08	B	Update A.C. Characteristics table to include Standard I ² C and Fast I ² C. Change logo and fine print to ON Semiconductor
06-May-09	C	Update D.C. Operating Characteristics table (Supplies)
14-June-10	D	Update Order Part Number table

ON Semiconductor and  are registered trademarks of Semiconductor Components Industries, LLC (SCILLC). SCILLC reserves the right to make changes without further notice to any products herein. SCILLC makes no warranty, representation or guarantee regarding the suitability of its products for any particular purpose, nor does SCILLC assume any liability arising out of the application or use of any product or circuit, and specifically disclaims any and all liability, including without limitation special, consequential or incidental damages. "Typical" parameters which may be provided in SCILLC data sheets and/or specifications can and do vary in different applications and actual performance may vary over time. All operating parameters, including "Typicals" must be validated for each customer application by customer's technical experts. SCILLC does not convey any license under its patent rights nor the rights of others. SCILLC products are not designed, intended, or authorized for use as components in systems intended for surgical implant into the body, or other applications intended to support or sustain life, or for any other application in which the failure of the SCILLC product could create a situation where personal injury or death may occur. Should Buyer purchase or use SCILLC products for any such unintended or unauthorized application, Buyer shall indemnify and hold SCILLC and its officers, employees, subsidiaries, affiliates, and distributors harmless against all claims, costs, damages, and expenses, and reasonable attorney fees arising out of, directly or indirectly, any claim of personal injury or death associated with such unintended or unauthorized use, even if such claim alleges that SCILLC was negligent regarding the design or manufacture of the part. SCILLC is an Equal Opportunity/Affirmative Action Employer. This literature is subject to all applicable copyright laws and is not for resale in any manner.

PUBLICATION ORDERING INFORMATION

LITERATURE FULFILLMENT:

Literature Distribution Center for ON Semiconductor
P.O. Box 5163, Denver, Colorado 80217 USA
Phone: 303-675-2175 or 800-344-3860 Toll Free USA/Canada
Fax: 303-675-2176 or 800-344-3867 Toll Free USA/Canada
Email: orderlit@onsemi.com

N. American Technical Support: 800-282-9855 Toll Free
USA/Canada
Europe, Middle East and Africa Technical Support:
Phone: 421 33 790 2910
Japan Customer Focus Center:
Phone: 81-3-5773-3850

ON Semiconductor Website: www.onsemi.com

Order Literature: <http://www.onsemi.com/orderlit>

For additional information, please contact your local Sales Representative