

Analog Peripherals

Two comparators

- Programmable hysteresis
- Configurable to generate interrupts or reset

V_{DD} Monitor and Brown-out Detector

On-Chip JTAG Debug

- On-chip emulation circuitry facilitates full-speed, non-intrusive, in-circuit emulation
- Supports breakpoints, single stepping, watchpoints, inspect/modify memory, and registers
- Superior performance to emulation systems using ICE-chips, target pods, and sockets
- Fully compliant with IEEE 1149.1 specification

Supply Voltage: 2.7 to 3.6 V

- Typical operating current: 9 mA at 25 MHz
- Typical stop mode current: <0.1 uA

High-Speed 8051 μ C Core

- Pipelined instruction architecture; executes 70% of instructions in 1 or 2 system clocks
- Up to 25 MIPS throughput with 25 MHz system clock
- Expanded interrupt handler; up to 21 interrupt sources

Memory

- 1280 bytes data RAM
- 8 kB Flash; in-system programmable in 512 byte sectors (512 bytes are reserved)

Digital Peripherals

- 32 port I/O; all are 5 V tolerant
- Hardware SPI™ and UART serial ports available concurrently
- 3 general-purpose 16-bit counter/timers
- Dedicated watchdog timer; bidirectional reset

Clock Sources

- Internal programmable oscillator: 2–16 MHz
- External oscillator: Crystal, RC, C, or Clock
- Can switch between clock sources on-the-fly

48-Pin TQFP

- Temperature Range: –40 to +85 °C

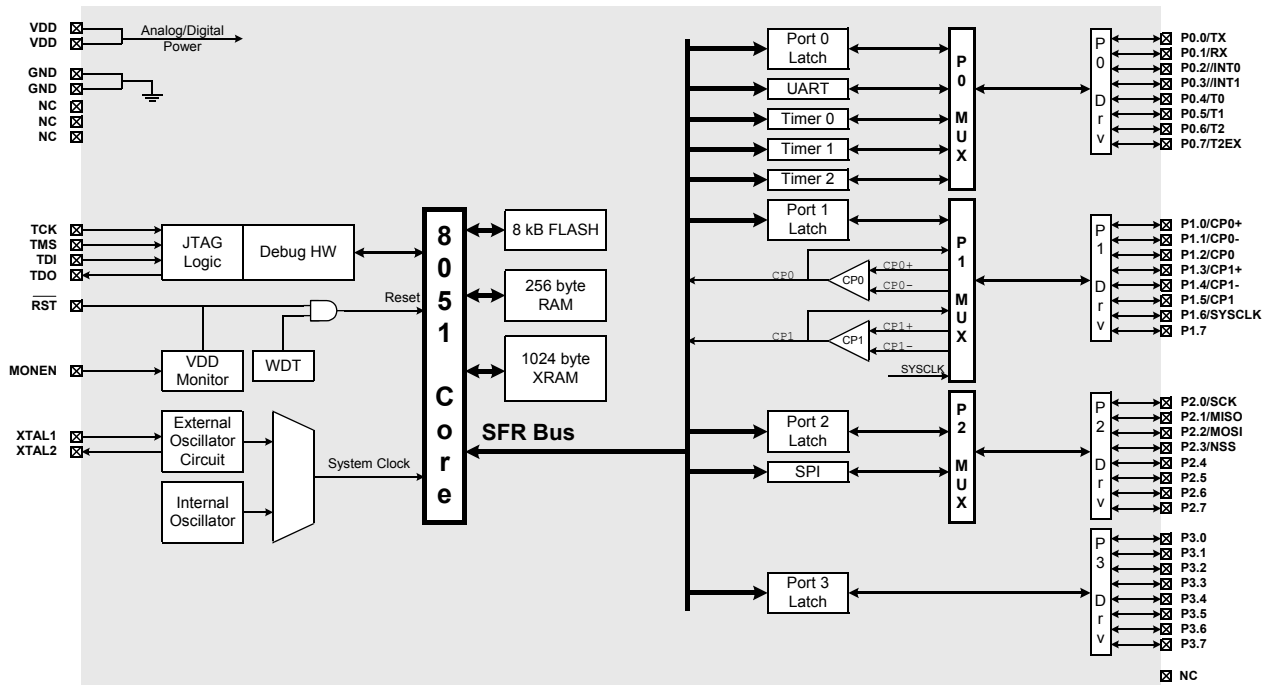

Selected Electrical Specifications

($T_A = -40$ to $+85$ °C, $V_{DD} = 2.7$ V unless otherwise specified unless otherwise specified)

PARAMETER	CONDITIONS	MIN	TYP	MAX	UNITS
GLOBAL CHARACTERISTICS					
Supply Voltage		2.7		3.6	V
Supply Current (CPU active)	Clock = 25 MHz		9		mA
	Clock = 1 MHz		0.4		mA
	Clock = 32 kHz; V_{DD} Monitor Disabled		11		μ A
Supply Current (shutdown)	Oscillator not running; V_{DD} Monitor Enabled		10		μ A
	Oscillator not running; V_{DD} Monitor Disabled		0.1		μ A
Clock Frequency Range		DC		25	MHZ
COMPARATORS					
Supply Current	(each comparator)		1.5		μ A
Response Time	(CP+) – (CP-) = 100 mV		4.0		μ s

Package Information

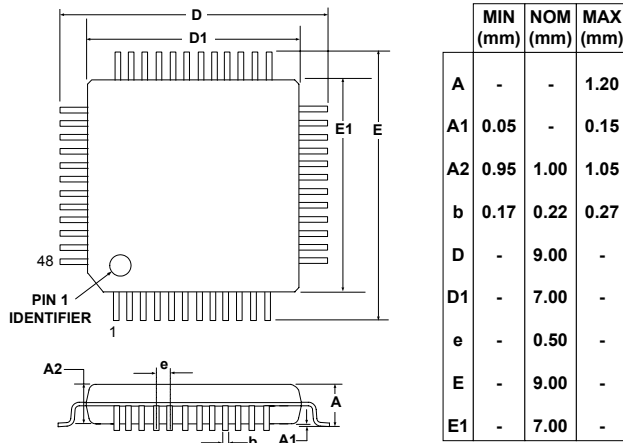

C8051F226DK Development Kit

