

Silicon NPN Power Transistors

BUV48 BUV48A

DESCRIPTION

- With TO-3PN package
- High voltage ,high speed

APPLICATIONS

- Switching regulators
- Inverters
- Solenoid and relay drivers
- Deflection circuits

PINNING (See Fig.2)

PIN	DESCRIPTION
1	Base
2	Collector;connected to mounting base
3	Emitter

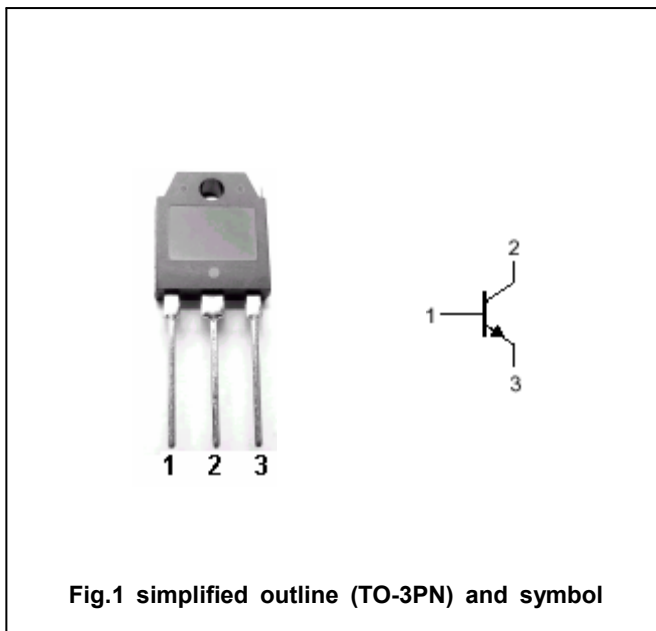

Fig.1 simplified outline (TO-3PN) and symbol

Absolute maximum ratings(Ta=25°C)

SYMBOL	PARAMETER	CONDITIONS	VALUE	UNIT
V _{CBO}	Collector-base voltage	BUV48	850	V
		BUV48A	1000	
V _{CEO}	Collector-emitter voltage	BUV48	400	V
		BUV48A	450	
V _{EBO}	Emitter-base voltage	Open collector	7	V
I _C	Collector current		15	A
I _{CM}	Collector current-peak		30	A
I _B	Base current		5	A
I _{BM}	Base current-peak		20	A
P _T	Total power dissipation	T _C =25°C	150	W
T _j	Junction temperature		150	°C
T _{stg}	Storage temperature		-65~175	°C

THERMAL CHARACTERISTICS

SYMBOL	PARAMETER	MAX	UNIT
R _{th j-c}	Thermal resistance from junction to case	1.0	°C/W

Silicon NPN Power Transistors

BUV48 BUV48A

CHARACTERISTICS

T_j=25 °C unless otherwise specified

SYMBOL	PARAMETER		CONDITIONS	MIN	TYP.	MAX	UNIT
V _{CEO(SUS)}	Collector-emitter sustaining voltage	BUV48	I _C =0.2A ; I _B =0; L=25mH	400			V
		BUV48A		450			
V _{EBO(BR)}	Emitter-base breakdown voltage		I _E =50mA; I _C =0	7			V
V _{CEsat-1}	Collector-emitter saturation voltage	BUV48	I _C =10A; I _B =2A T _C =100 °C			1.5 2.0	V
		BUV48A	I _C =8A ; I _B =1.6A T _C =100 °C			1.5 2.0	
V _{CEsat-2}	Collector-emitter saturation voltage	BUV48	I _C =15A ; I _B =3A			5.0	V
		BUV48A	I _C =12A ; I _B =2.4A				
V _{BEsat}	Base-emitter saturation voltage	BUV48	I _C =10A; I _B =2A T _C =100 °C			1.6	V
		BUV48A	I _C =8A ; I _B =1.6A T _C =100 °C				
I _{CEX}	Collector cut-off current		V _{CEX} =rated V _{CE} S; V _{BE(off)} =1.5V T _C =125 °C			0.2 2.0	mA
I _{EBO}	Emitter cut-off current		V _{EB} =5V; I _C =0			0.1	mA
h _{FE}	DC current gain	BUV48	I _C =10A ; V _{CE} =5V	8			
		BUV48A	I _C =8A ; V _{CE} =5V				
C _{OB}	Output capacitance		I _E =0 ; V _{CB} =10V, f=1MHz			350	pF

Switching times resistive load

t _d	Delay time	for BUV48 I _C =10A ; I _{B1} =2A; V _{CC} =300V V _{BE(off)} =5V		0.1	0.2	μs
t _r	Rise time			0.4	0.7	μs
t _s	Storage time	for BUV48A I _C =8A ; I _{B1} =1.6A; V _{CC} =300V V _{BE(off)} =5V		1.3	2.0	μs
t _f	Fall time			0.2	0.4	μs

Silicon NPN Power Transistors

BUV48 BUV48A

PACKAGE OUTLINE

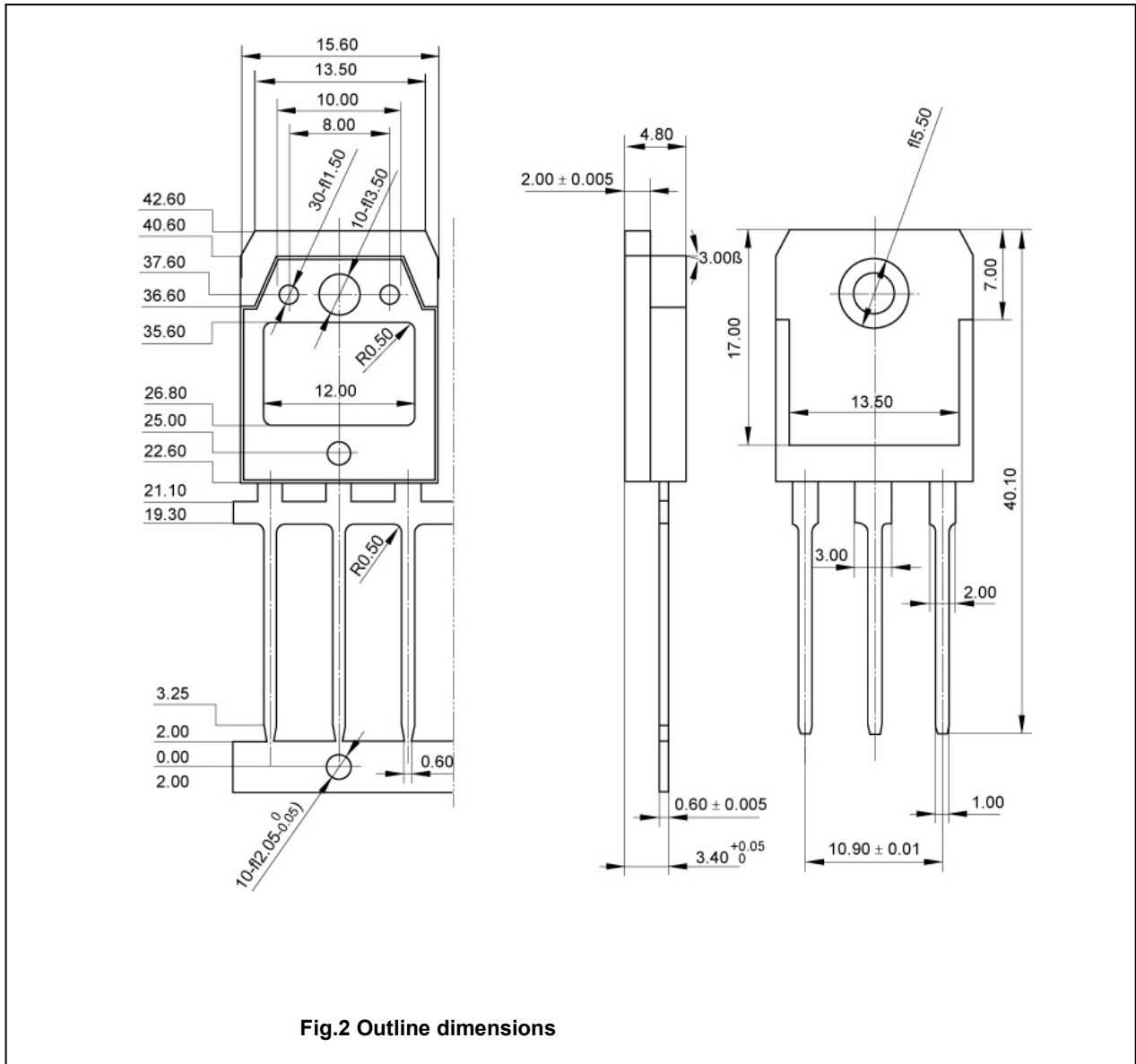

Fig.2 Outline dimensions