

Silicon NPN Power Transistor

BUL58D

DESCRIPTION

- High Voltage Capability
- High Speed Switching
- Integrated Antiparallel Collector-Emitter Diode

APPLICATIONS

- Electronic ballasts for fluorescent lighting
- Electronic transformers for halogen lamps
- Switch mode power supply

ABSOLUTE MAXIMUM RATINGS(T_a=25°C)

SYMBOL	PARAMETER	VALUE	UNIT
V _{CEs}	Collector- Emitter Voltage	800	V
V _{CEO}	Collector-Emitter Voltage	450	V
V _{EBO}	Emitter-Base Voltage	9	V
I _C	Collector Current	8	A
I _{CM}	Collector Peak Current	16	A
I _B	Base Current	4	A
I _{BM}	Base Peak Current	8	A
P _C	Collector Power Dissipation @T _C =25°C	85	W
T _j	Junction Temperature	150	°C
T _{stg}	Storage Temperature	-65~150	°C

THERMAL CHARACTERISTICS

SYMBOL	PARAMETER	MAX	UNIT
R _{th j-c}	Thermal Resistance, Junction to Case	1.47	°C/W
R _{th j-a}	Thermal Resistance, Junction to Ambient	62.5	°C/W

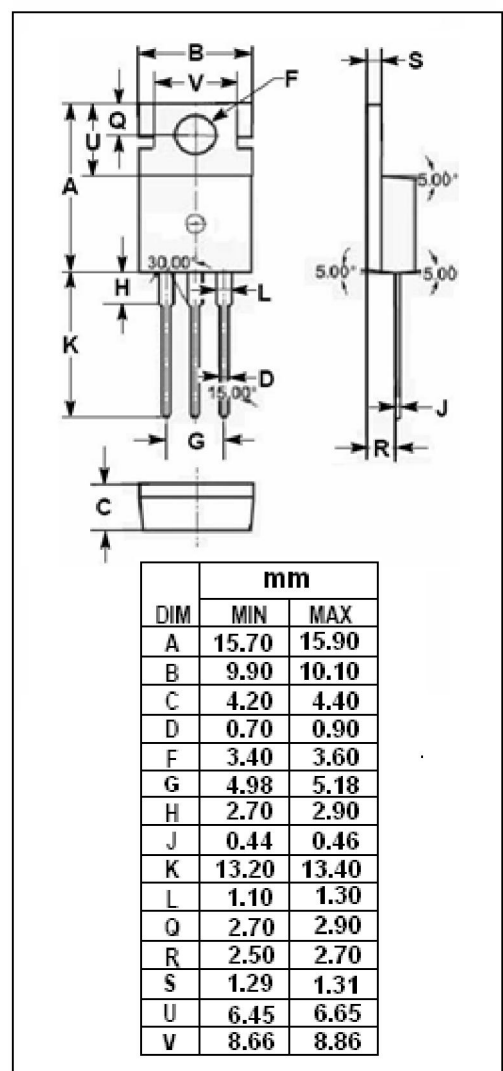
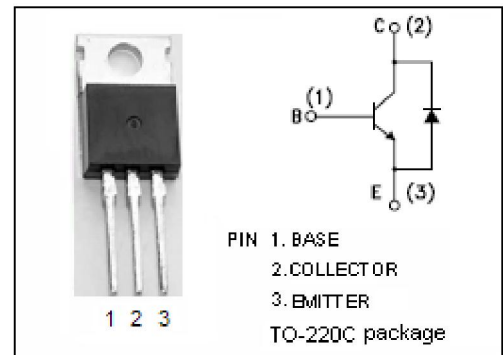

Silicon NPN Power Transistor

BUL58D

ELECTRICAL CHARACTERISTICS

 $T_C=25^\circ\text{C}$ unless otherwise specified

SYMBOL	PARAMETER	CONDITIONS	MIN	TYP	MAX	UNIT
$V_{CEO(sus)}$	Collector-Emitter Sustaining Voltage	$I_C = 100\text{mA}$; $L = 25\text{ mH}$	450			V
$V_{(BR)EBO}$	Emitter-Base Breakdown Voltage	$I_{EB} = 10\text{mA}$; $I_C = 0$	9			V
$V_{CE(sat)-1}$	Collector-Emitter Saturation Voltage	$I_C = 4\text{A}$; $I_B = 0.8\text{A}$			1.5	V
$V_{CE(sat)-2}$	Collector-Emitter Saturation Voltage	$I_C = 5\text{A}$; $I_B = 1\text{A}$			2	V
$V_{BE(sat)-1}$	Base-Emitter Saturation Voltage	$I_C = 4\text{A}$; $I_B = 0.8\text{A}$			1.3	V
$V_{BE(sat)-2}$	Base-Emitter Saturation Voltage	$I_C = 5\text{A}$; $I_B = 1\text{A}$			1.5	V
I_{CES}	Collector Cutoff Current	$V_{CE} = 800\text{V}$; $V_{BE} = 0$ $T_j = 125^\circ\text{C}$			200 500	μA
I_{CEO}	Collector Emitter Current	$V_{CE} = 450\text{V}$; $I_B = 0$			200	μA
h_{FE-1}	DC Current Gain	$I_C = 5\text{A}$; $V_{CE} = 5\text{V}$	5			
h_{FE-2}	DC Current Gain	$I_C = 0.5\text{A}$; $V_{CE} = 5\text{V}$	10		40	
V_F	Diode Forward Voltage	$I_F = 3\text{A}$			3.0	V

Switching Times

t_s	Storage Time	$I_C = 2\text{A}$, $I_{B1} = 0.4\text{A}$ $V_{BE(off)} = -5\text{V}$, $R_{BB} = 0\ \Omega$ $V_{CL} = 250\text{V}$, $L = 200\text{ mH}$			1.8	μs
t_f	Fall Time				180	ns
t_s	Storage Time	$I_C = 2\text{A}$; $I_{B1} = 0.4\text{A}$ $V_{BE(off)} = -5\text{V}$; $R_{BB} = 0\ \Omega$ $V_{CL} = 250\text{V}$; $L = 200\text{ mH}$ $T_j = 125^\circ\text{C}$		1.5		μs
t_f	Fall Time			180		ns