

18-CHANNEL GAMMA VOLTAGE GENERATOR WITH TWO PROGRAMMABLE V_{COM} CHANNELS

Check for Samples: [BUF20800-Q1](#)

FEATURES

- Qualified for Automotive Applications
- 18-Channel Gamma Correction
- 2-Channel Programmable V_{COM} : 50 mA I_{OUT}
- 10-Bit Resolution
- Rail-to-Rail Output
- Low Supply Current: 900 μ A/ch
- Supply Voltage: 7 V to 18 V
- Digital Supply: 2.0 V to 5.5 V
- Industry-Standard, Two-Wire Interface: 3.4 MHz High-Speed Mode
- Demo Board and Software Available

APPLICATIONS

- Replaces Resistor-Based Gamma Solutions
- TFT-LCD Reference Drivers
- Dynamic Gamma Control

DESCRIPTION

The BUF20800-Q1 is a programmable voltage reference generator designed for gamma correction in TFT-LCD panels. It provides 18 programmable outputs for gamma correction and two channels for V_{COM} adjustment, each with 10-bit resolution.

This programmability replaces the traditional, time consuming process of changing resistor values to optimize the various gamma voltages and allows designers to determine the correct gamma voltages for a panel very quickly. Required changes can also be easily implemented without hardware changes.

The BUF20800-Q1 uses TI's latest, small-geometry analog CMOS process, which makes it a very competitive choice for full production, not just evaluation.

Programming of each output occurs through an industry standard, two-wire serial interface. Unlike existing programmable buffers, the BUF20800-Q1 offers a high-speed mode that allows clock speeds up to 3.4 MHz.

For lower channel count, please contact your local sales or marketing representative.

The BUF20800-Q1 is available in an HTSSOP-38 PowerPAD™ package. It is specified from -40°C to $+105^{\circ}\text{C}$.

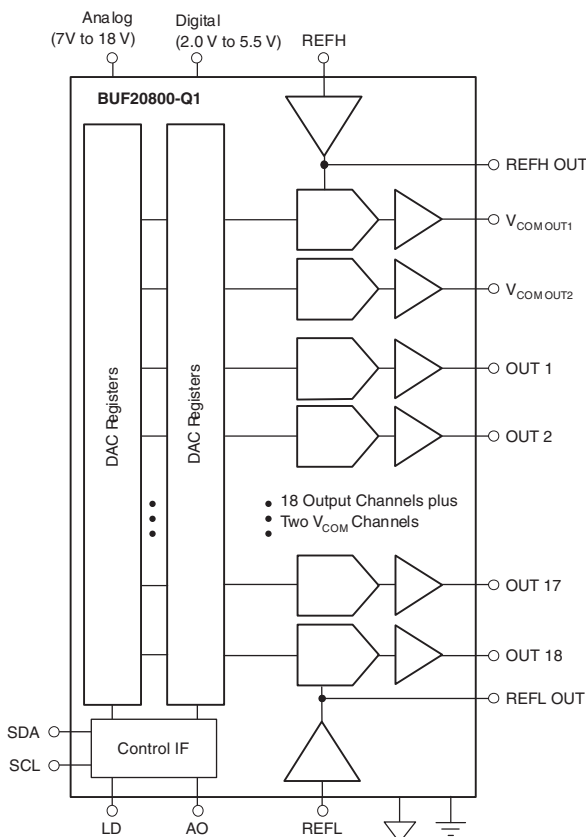

RELATED PRODUCTS

| FEATURES | PRODUCT |
|--|--------------------------|
| 18-Channel Programmable, Two V_{COM} + OTP Memory | BUF20820 |
| 12-Channel Programmable Buffer, 10-Bit | BUF12800 |
| Programmable V_{COM} | BUF01900 |
| 11-, 6-, 4-Channel Gamma Correction Buffer, 18V Supply | BUFxx704 |
| High-Speed V_{COM} , 1 and 2 Channels | SN10501 |
| Complete LCD DC/DC Solution | TPS65100 |



Please be aware that an important notice concerning availability, standard warranty, and use in critical applications of Texas Instruments semiconductor products and disclaimers thereto appears at the end of this data sheet.

PowerPAD is a trademark of Texas Instruments.

PRODUCTION DATA information is current as of publication date. Products conform to specifications per the terms of the Texas Instruments standard warranty. Production processing does not necessarily include testing of all parameters.



This integrated circuit can be damaged by ESD. Texas Instruments recommends that all integrated circuits be handled with appropriate precautions. Failure to observe proper handling and installation procedures can cause damage.

ESD damage can range from subtle performance degradation to complete device failure. Precision integrated circuits may be more susceptible to damage because very small parametric changes could cause the device not to meet its published specifications.

ORDERING INFORMATION⁽¹⁾

| PRODUCT | PACKAGE | PACKAGE DESIGNATOR | PACKAGE MARKING |
|-------------|-----------|--------------------|-----------------|
| BUF20800-Q1 | HTSSOP-38 | DCP | BUF20800Q |

(1) For the most current package and ordering information see the Package Option Addendum at the end of this document, or see the TI web site at www.ti.com.

ABSOLUTE MAXIMUM RATINGS⁽¹⁾

over operating free-air temperature range (unless otherwise noted).

| PARAMETER | | VALUE | UNIT |
|--|-----------------------|-------------|------|
| V _S | Supply voltage | 19 | V |
| V _{SD} | Supply voltage | 6 | V |
| Signal input terminals, SCL, SDA, AO, LD | Voltage | -0.5 to 6 | V |
| | Current | ±10 | mA |
| Output Short-Circuit ⁽²⁾ | | Continuous | |
| T _A | Operating temperature | -40 to +105 | °C |
| T _{stg} | Storage temperature | -65 to +150 | °C |
| T _J | Junction temperature | 125 | °C |
| Latch-up per JESD78B | | Class 1 | |

- (1) Stresses above these ratings may cause permanent damage. Exposure to absolute maximum conditions for extended periods may degrade device reliability. These are stress ratings only, and functional operation of the device at these or any other conditions beyond those specified is not implied.
- (2) Short-circuit to ground, one channel at a time.

ELECTRICAL CHARACTERISTICS

Boldface limits apply over the specified temperature range, $T_A = -40^\circ\text{C}$ to $+105^\circ\text{C}$.

At $T_A = 25^\circ\text{C}$, $V_S = 18\text{ V}$, $V_{SD} = 5\text{ V}$, $R_L = 1.5\text{ k}\Omega$ connected to ground, and $C_L = 200\text{ pF}$, unless otherwise noted.

| PARAMETER | CONDITIONS | BUF20800-Q1 | | | UNIT |
|---|--|---------------------|------------|--------------------------|---------------------------------|
| | | MIN | TYP | MAX | |
| ANALOG | | | | | |
| Gamma Output Swing: High | OUT 1–9, Sourcing 10 mA, $V_{REFH} = 17.8\text{ V}$, Code 1023 | 17.7 | 17.8 | | V |
| | OUT 10–18, Sourcing 10 mA, $V_{REFH} = 17.8\text{ V}$, Code 1023 | 17.0 | 17.2 | | V |
| Gamma Output Swing: Low | OUT 1–9, Sinking 10 mA, $V_{REFL} = 0.2\text{ V}$, Code 00 | | 0.6 | 1.0 | V |
| | OUT 10–18, Sinking 10 mA, $V_{REFL} = 0.2\text{ V}$, Code 00 | | 0.2 | 0.3 | V |
| V_{COM} Buffer Output Swing: High | V_{COM} , Sourcing 50 mA, $V_{REFH} = 17.8\text{ V}$ | 13 | 15.5 | | V |
| V_{COM} Buffer Output Swing: Low | V_{COM} , Sinking 50 mA, $V_{REFL} = 0.2\text{ V}$ | | 1 | 2.0 | V |
| Output Current ⁽¹⁾ | I_O All Channels, Code 512, Sinking/Sourcing | 40 | 45 | | mA |
| REFH Input Range ⁽²⁾ | | 4 | | V_S | V |
| REFL Input Range ⁽²⁾ | | GND | | $V_S - 4$ | V |
| Integral Nonlinearity | INL No Load, $V_{REFH} = 17\text{ V}$, $V_{REFL} = 1\text{ V}$ | | 0.3 | 1.5 | Bits |
| Differential Nonlinearity | DNL No Load, $V_{REFH} = 17\text{ V}$, $V_{REFL} = 1\text{ V}$ | | 0.3 | 1 | Bits |
| Gain Error | | | 0.12 | | % |
| Program to Out Delay | t_D | | 5 | | μs |
| Output Accuracy | No Load, $V_{REFH} = 17\text{ V}$, $V_{REFL} = 1\text{ V}$ | | ± 20 | ± 50 | mV |
| Over Temperature | | | ± 25 | | mV |
| Input Resistance at V_{REFH} and V_{REFL} | R_{INH} | | 100 | | M Ω |
| Load Regulation, All References | REG $V_{OUT} = V_S/2$, $I_{OUT} = 5\text{ mA}$ to -5 mA Step | | 0.5 | 1.5 | mV/mA |
| 40 mA, All Channels | $V_{OUT} = V_S/2$, $I_{SINKING} = 40\text{ mA}$, $I_{SOURCING} = 40\text{ mA}$ | | 0.5 | 1.5 | mV/mA |
| ANALOG POWER SUPPLY | | | | | |
| Operating Range | V_S | 7 | | 18 | V |
| Total Analog Supply Current | I_S No Load | | 18 | 28 | mA |
| Over Temperature | | | | 28 | mA |
| DIGITAL | | | | | |
| Logic 1 Input Voltage | V_{IH} | $0.7 \times V_{SD}$ | | | V |
| Logic 0 Input Voltage | V_{IL} | | | $0.3 \times V_{SD}$ | V |
| Logic 0 Output Voltage | V_{OL} $I_{SINK} = 3\text{ mA}$ | | 0.15 | 0.4 | V |
| Input Leakage | | | ± 0.01 | ± 10 | μA |
| Clock Frequency | f_{CLK} Standard/Fast Mode High-Speed Mode | | | 400 3.4 | kHz MHz |
| DIGITAL POWER SUPPLY | | | | | |
| Operating Range | V_{SD} | 2.0 | | 5.5 | V |
| Digital Supply Current ⁽³⁾ | I_{SD} Outputs at Reset Values, No Load, Two-Wire Bus Inactive | | 25 | 50 | μA |
| Over Temperature | | | 100 | | μA |
| TEMPERATURE RANGE | | | | | |
| Operating Temperature Range | Junction Temperature $< +125^\circ\text{C}$ | -40 | | +105 | $^\circ\text{C}$ |
| Storage Temperature Range | | -65 | | +150 | $^\circ\text{C}$ |
| Thermal Resistance, HTSSOP-38 | | | | | |
| Junction-to-Ambient | θ_{JA} | | 30 | | $^\circ\text{C/W}$ |
| Junction-to-Case | θ_{JC} | | 15 | | $^\circ\text{C/W}$ |

(1) See typical characteristic graph [Output Voltage vs Output Current](#).

(2) See application information section REFH and REFL Input Range.

(3) See typical characteristic graph [Digital Supply Current vs Temperature](#).

PIN CONFIGURATION

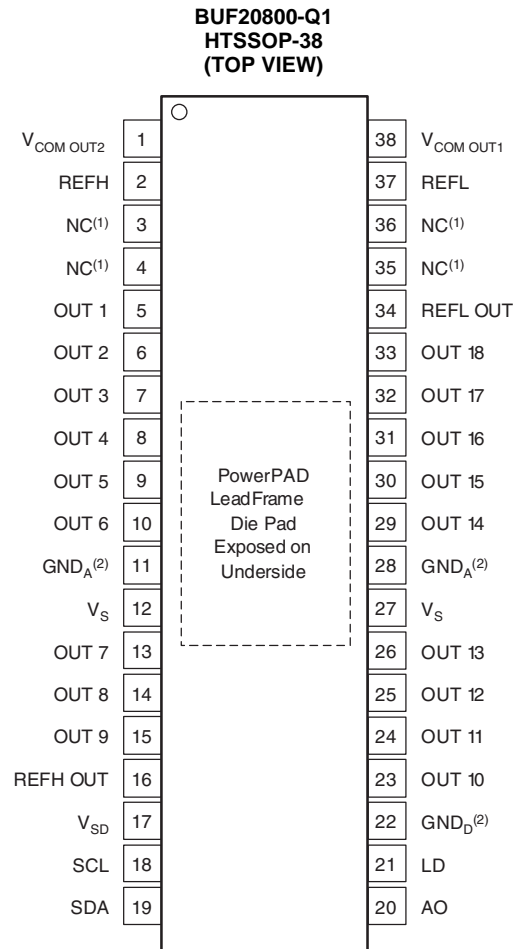

- (1) NC denotes no connection
- (2) GND_D and GND_A are internally connected and must be at the same voltage potential.

TYPICAL CHARACTERISTICS

At $T_A = 25^\circ\text{C}$, $V_S = 18\text{ V}$, $V_{SD} = 5\text{ V}$, $V_{REFH} = 17\text{ V}$, $V_{REFL} = 1\text{ V}$, $R_L = 1.5\text{ k}\Omega$ connected to ground, and $C_L = 200\text{ pF}$, unless otherwise noted.

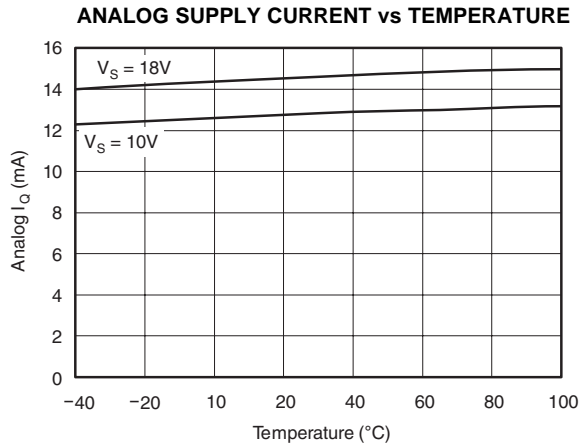

Figure 1.

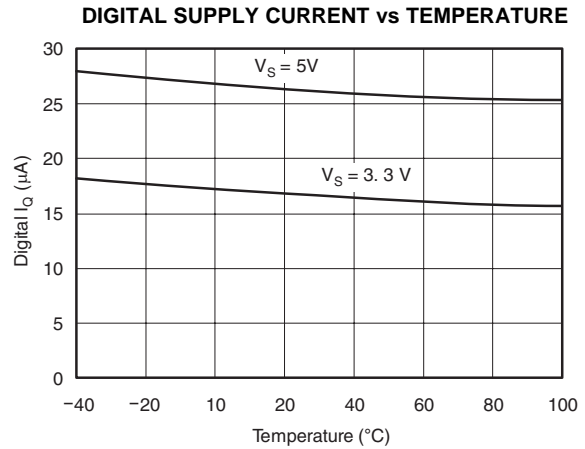

Figure 2.

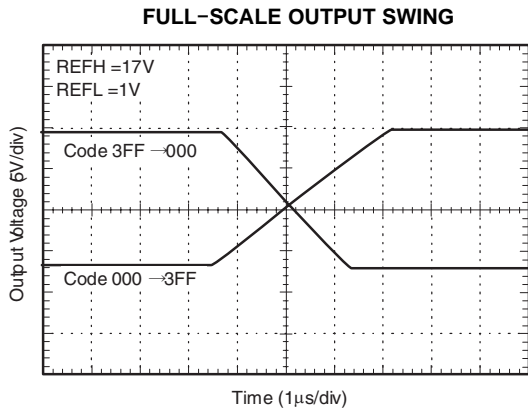

Figure 3.

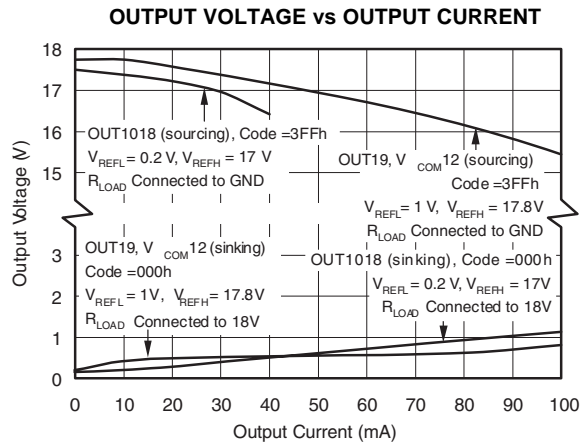

Figure 4.

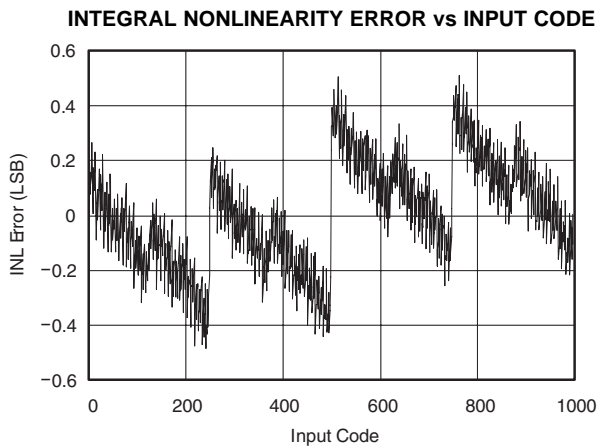

Figure 5.

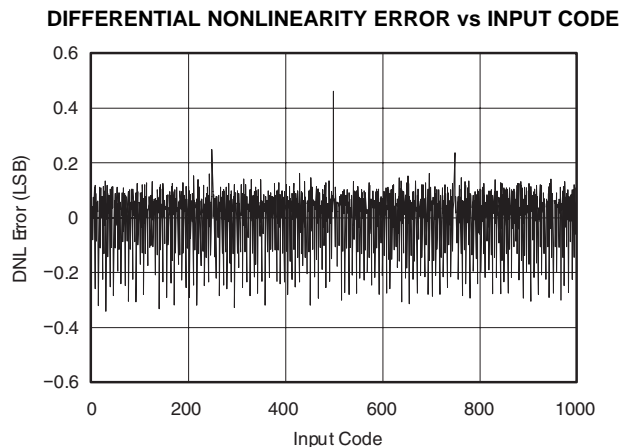

Figure 6.

APPLICATION INFORMATION

The BUF20800-Q1 programmable voltage reference allows fast, easy adjustment of 18 programmable reference outputs and two channels for V_{COM} adjustment, each with 10-bit resolution. It offers very simple, time-efficient adjustment of the gamma reference and V_{COM} voltages. The BUF20800-Q1 is programmed through a high-speed, standard, two-wire interface. The BUF20800-Q1 features a double-register structure for each DAC channel to simplify the implementation of dynamic gamma control. This structure allows pre-loading of register data and rapid updating of all channels simultaneously.

Buffers 1–9 are able to swing to within 200mV of the positive supply rail, and to within 0.6V of the negative supply rail. Buffers 10–18 are able to swing to within 0.8V of the positive supply rail and to within 200mV of the negative supply rail.

The BUF20800-Q1 can be powered using an analog supply voltage from 7V to 18V, and a digital supply from 2V to 5.5V. The digital supply must be applied prior to or simultaneously with the analog supply to avoid excessive current and power consumption; damage to the device may occur if it is left connected only to the analog supply for extended periods of time. [Figure 7](#) shows the power supply timing requirements.

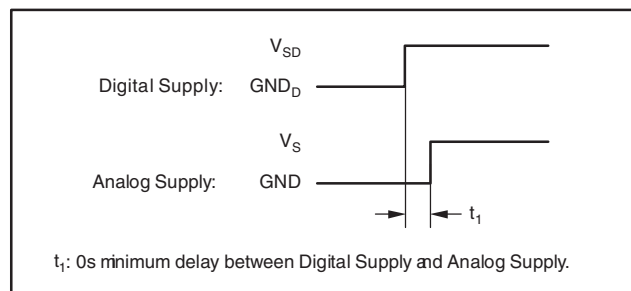

Figure 7. Power Supply Timing Requirements

[Figure 8](#) shows the BUF20800-Q1 in a typical configuration. In this configuration, the BUF20800-Q1 device address is 74h. The output of each digital-to-analog converter (DAC) is immediately updated as soon as data are received in the corresponding register ($LD = 0$).

For maximum dynamic range, set $V_{REFH} = V_S - 0.2 \text{ V}$ and $V_{REFL} = GND + 0.2 \text{ V}$.

TWO-WIRE BUS OVERVIEW

The BUF20800-Q1 communicates through an industry standard, two-wire interface to receive data in slave mode. This standard uses a two-wire, open-drain interface that supports multiple devices on a single bus. Bus lines are driven to a logic low level only. The device that initiates the communication is called a master, and the devices controlled by the master are slaves. The master generates the serial clock on the clock signal line (SCL), controls the bus access, and generates the START and STOP conditions.

To address a specific device, the master initiates a START condition by pulling the data signal line (SDA) from a HIGH to a LOW logic level while SCL is HIGH. All slaves on the bus shift in the slave address byte, with the last bit indicating whether a read or write operation is intended. During the 9th clock pulse, the slave being addressed responds to the master by generating an Acknowledge and pulling SDA LOW.

Data transfer is then initiated and eight bits of data are sent followed by an Acknowledge Bit. During data transfer, SDA must remain stable while SCL is HIGH. Any change in SDA while SCL is HIGH will be interpreted as a START or STOP condition.

Once all data has been transferred, the master generates a STOP condition indicated by pulling SDA from LOW to HIGH while SCL is HIGH.

The BUF20800-Q1 can act only as a slave device; therefore, it never drives SCL. SCL is only an input for the BUF20800-Q1. [Table 1](#) and [Table 2](#) summarize the address and command codes, respectively, for the BUF20800-Q1.

ADDRESSING THE BUF20800-Q1

The address of the BUF20800-Q1 is 111010x, where x is the state of the A0 pin. When the A0 pin is LOW, the device will acknowledge on address 74h (1110100). If the A0 pin is HIGH, the device will acknowledge on address 75h (1110101).

Other valid addresses are possible through a simple mask change. Contact your TI representative for information.

Table 1. Quick-Reference Table of BUF20800-Q1 Addresses

| DEVICE/COMPONENT | ADDRESS |
|--|---------|
| BUF20800-Q1 Address: | |
| A0 pin is LOW (device acknowledges on address 74h) | 1110100 |
| A0 pin is HIGH (device acknowledges on address 75h) | 1110101 |

Table 2. Quick-Reference Table of Command Codes

| COMMAND | CODE |
|--------------------|--|
| General Call Reset | Address byte of 00h followed by a data byte of 06h. |
| High-Speed Mode | 00001xxx, with SCL ≤ 400kHz; where xxx are bits unique to the Hs-capable master. This byte is called the Hs master code. |

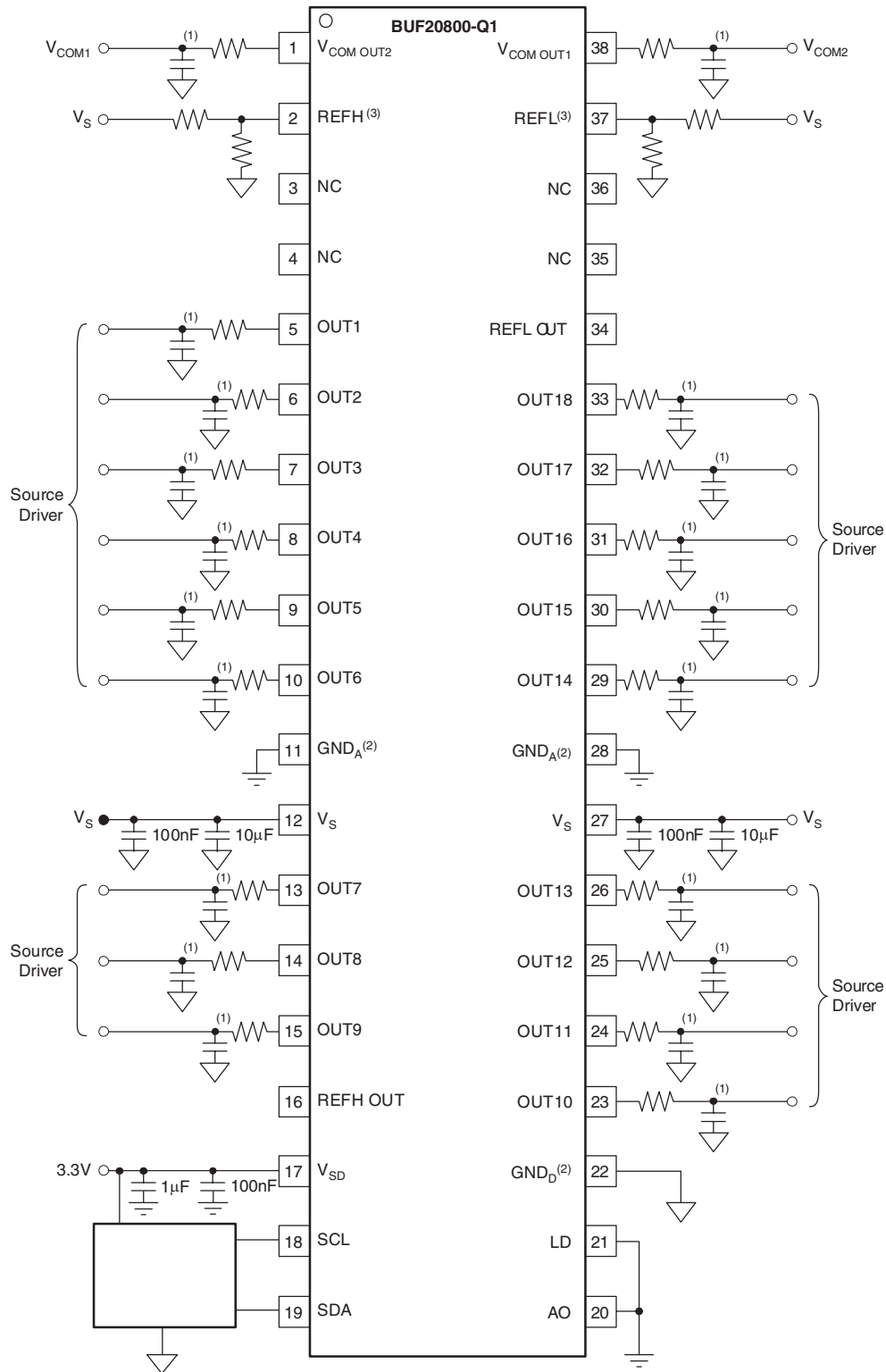

- (1) RC combination optional.
- (2) GND_A and GND_D must be connected together.
- (3) Connecting a capacitor to this node is not recommended.

Figure 8. Typical Application Configuration

DATA RATES

The two-wire bus operates in one of three speed modes:

- Standard: allows a clock frequency of up to 100kHz;
- Fast: allows a clock frequency of up to 400kHz; and
- High-speed mode (also called Hs mode): allows a clock frequency of up to 3.4MHz.

The BUF20800-Q1 is fully compatible with all three modes. No special action is required to use the device in Standard or Fast modes, but High-speed mode must be activated. To activate High-speed mode, send a special address byte of 00001xxx, with SCL = 400kHz, following the START condition; xxx are bits unique to the Hs-capable master, which can be any value. This byte is called the Hs master code. (Note that this is different from normal address bytes—the low bit does not indicate read/write status.) The BUF20800-Q1 will respond to the High-speed command regardless of the value of these last three bits. The BUF20800-Q1 will not acknowledge this byte; the communication protocol prohibits acknowledgment of the Hs master code. On receiving a master code, the BUF20800-Q1 will switch on its Hs mode filters, and communicate at up to 3.4MHz. Additional high-speed transfers may be initiated without resending the Hs mode byte by generating a repeat START without a STOP. The BUF20800-Q1 will switch out of Hs mode with the next STOP condition.

GENERAL-CALL RESET AND POWER-UP

The BUF20800-Q1 responds to a General Call Reset, which is an address byte of 00h (0000 0000) followed by a data byte of 06h (0000 0110). The BUF20800-Q1 acknowledges both bytes. Upon receiving a General Call Reset, the BUF20800-Q1 performs a full internal reset, as though it had been powered off and then on. It always acknowledges the General Call address byte of 00h (0000 0000), but does not acknowledge any General Call data bytes other than 06h (0000 0110).

The BUF20800-Q1 automatically performs a reset upon power up. As part of the reset, all outputs are set to $(V_{REFH} - V_{REFL})/2$. Other reset values are available as a custom modification—contact your TI representative for details.

The BUF20800-Q1 resets all outputs to $(V_{REFH} - V_{REFL})/2$ after sending the device address, if a valid DAC address is sent with bits D7 to D5 set to '100'. If these bits are set to '010', only the DAC being addressed in this most significant byte (MSB) and the following least significant byte (LSB) will be reset.

OUTPUT VOLTAGE

Buffer output values are determined by the reference voltages (VREFH and VREFL) and the decimal value of the binary input code used to program that buffer. The value is calculated using [Equation 1](#):

$$V_{OUT} = \left[\frac{V_{REFH} - V_{REFL}}{1024} \times \text{Decimal Value of Code} \right] + V_{REFL} \quad (1)$$

The valid voltage ranges for the reference voltages are:

$$4V \leq V_{REFH} - V_S \leq 0.2V \text{ and } 0.2V \leq V_{REFL} \leq V_S - 4V \quad (2)$$

The BUF20800-Q1 outputs are capable of a full-scale voltage output change in typically 5 μ s—no intermediate steps are required.

OUTPUT LATCH

Updating the DAC register is not the same as updating the DAC output voltage, because the BUF20800-Q1 features a double-buffered register structure. There are three methods for latching transferred data from the storage registers into the DACs to update the DAC output voltages.

Method 1 requires externally setting the latch pin (LD) LOW, LD = LOW, which will update each DAC output voltage whenever its corresponding register is updated.

Method 2 externally sets LD = HIGH to allow all DAC output voltages to retain their values during data transfer and until LD = LOW, which will then simultaneously update the output voltages of all DACs to the new register values. Use this method to transfer a future data set in advance to prepare for a very fast output voltage update.

Method 3 uses software control. LD is maintained HIGH, and all DACs are updated when the master writes a 1 in bit 15 of any DAC register. The update will occur after receiving the 16-bit data for the currently-written register.

The General Call Reset and the power-up reset will update the DAC regardless of the state of the latch pin.

READ/WRITE OPERATIONS

The BUF20800-Q1 is able to read from a single DAC, or multiple DACs, or write to the register of a single DAC, or multiple DACs in a single communication transaction. DAC addresses begin with 0000 0000, which corresponds to DAC_1, through 0001 0011, which corresponds to V_{COM} OUT2.

Write commands are performed by setting the read/write bit LOW. Setting the read/write bit HIGH will perform a read transaction.

Writing

To write to a single DAC register

1. Send a START condition on the bus.
2. Send the device address and read/write bit = LOW. The BUF20800-Q1 will acknowledge this byte.
3. Send a DAC address byte. Bits D7–D5 must be set to 0. Bits D4–D0 are the DAC address. Only DAC addresses 00000 to 10011 are valid and will be acknowledged. Table 3 shows the DAC addresses.
4. Send two bytes of data for the specified DAC register. Begin by sending the most significant byte first (bits D15–D8, of which only bits D9 and D8 are used, and bits D15–D14 must not be 01), followed by the least significant byte (bits D7–D0). The register is updated after receiving the second byte.
5. Send a STOP condition on the bus

Table 3. DAC Addresses

| DAC | ADDRESS |
|-----------------------|-----------|
| DAC_1 | 0000 0000 |
| DAC_2 | 0000 0001 |
| DAC_3 | 0000 0010 |
| DAC_4 | 0000 0011 |
| DAC_5 | 0000 0100 |
| DAC_6 | 0000 0101 |
| DAC_7 | 0000 0110 |
| DAC_8 | 0000 0111 |
| DAC_9 | 0000 1000 |
| DAC_10 | 0000 1001 |
| DAC_11 | 0000 1010 |
| DAC_12 | 0000 1011 |
| DAC_13 | 0000 1100 |
| DAC_14 | 0000 1101 |
| DAC_15 | 0000 1110 |
| DAC_16 | 0000 1111 |
| DAC_17 | 0001 0000 |
| DAC_18 | 0001 0001 |
| V _{COM} OUT1 | 0001 0010 |
| V _{COM} OUT2 | 0001 0011 |

The BUF20800-Q1 will acknowledge each data byte. If the master terminates communication early by sending a STOP or START condition on the bus, the specified register will not be updated. Updating the DAC register is not the same as updating the DAC output voltage. See the Output Latch section.

The process of updating multiple DAC registers begins the same as when updating a single register. However, instead of sending a STOP condition after writing the addressed register, the master continues to send data for the next register. The BUF20800-Q1 automatically and sequentially steps through subsequent registers as additional data is sent. The process continues until all desired registers have been updated or a STOP condition is sent.

To write to multiple DAC registers:

1. Send a START condition on the bus.
2. Send the device address and read/write bit = LOW. The BUF20800-Q1 will acknowledge this byte.
3. Send either the DAC_1 address byte to start at the first DAC, or send the address byte for whichever DAC will be the first in the sequence of DACs to be updated. The BUF20800-Q1 will begin with this DAC and step through subsequent DACs in sequential order.
4. Send the bytes of data; begin by sending the most significant byte (bits D15–D8, of which only bits D9 and D8 have meaning), followed by the least significant byte (bits D7–D0). The first two bytes are for the DAC addressed in step 3 above. Its register is automatically updated after receiving the second byte. The next two bytes are for the following DAC. That DAC register is updated after receiving the fourth byte. This process continues until the registers of all following DACs have been updated.
5. Send a STOP condition on the bus.

The BUF20800-Q1 will acknowledge each byte. To terminate communication, send a STOP or START condition on the bus. Only DAC registers that have received both bytes of data will be updated.

Reading

Reading a DAC register will return the data stored in the DAC. This data can differ from the data stored in the DAC register. See the [Output Latch](#) section.

To read the DAC value:

1. Send a START condition on the bus.
2. Send the device address and read/write bit = LOW. The BUF20800-Q1 will acknowledge this byte.
3. Send the DAC address byte. Bits D7–D5 must be set to 0; Bits D4–D0 are the DAC address. Only DAC addresses 00000 to 10011 are valid and will be acknowledged.
4. Send a START or STOP/START condition on the bus.
5. Send correct device address and read/write bit = HIGH. The BUF20800-Q1 will acknowledge this byte.
6. Receive two bytes of data. They are for the specified DAC. The first received byte is the most significant byte (bits D15–D8; only bits D9 and D8 have meaning); the next byte is the least significant byte (bits D7–D0).
7. Acknowledge after receiving the first byte.
8. Do not acknowledge the second byte to end the read transaction.

Communication may be terminated by sending a premature STOP or START condition on the bus, or by not sending the acknowledge.

To Read Multiple DACs:

1. Send a START condition on the bus.
2. Send the device address and read/write bit = LOW. The BUF20800-Q1 will acknowledge this byte.
3. Send either the DAC_1 address byte to start at the first DAC, or send the address byte for whichever DAC will be the first in the sequence of DACs to be read. The BUF20800-Q1 will begin with this DAC and step through subsequent DACs in sequential order.
4. Send a START or STOP/START condition on the bus.
5. Send correct device address and read/write bit = HIGH. The BUF20800-Q1 will acknowledge this byte.
6. Receive two bytes of data. They are for the specified DAC. The first received byte is the most significant byte (bits D15–D8, only bits D9 and D8 have meaning); the next byte is the least significant byte (bits D7–D0).
7. Acknowledge after receiving each byte of data except for the last byte. The acknowledge bit of the last byte should be HIGH to end the read operation.
8. When all desired DACs have been read, send a STOP or repeated START condition on the bus.

Communication may be terminated by sending a premature STOP or START condition on the bus, or by not sending the acknowledge.

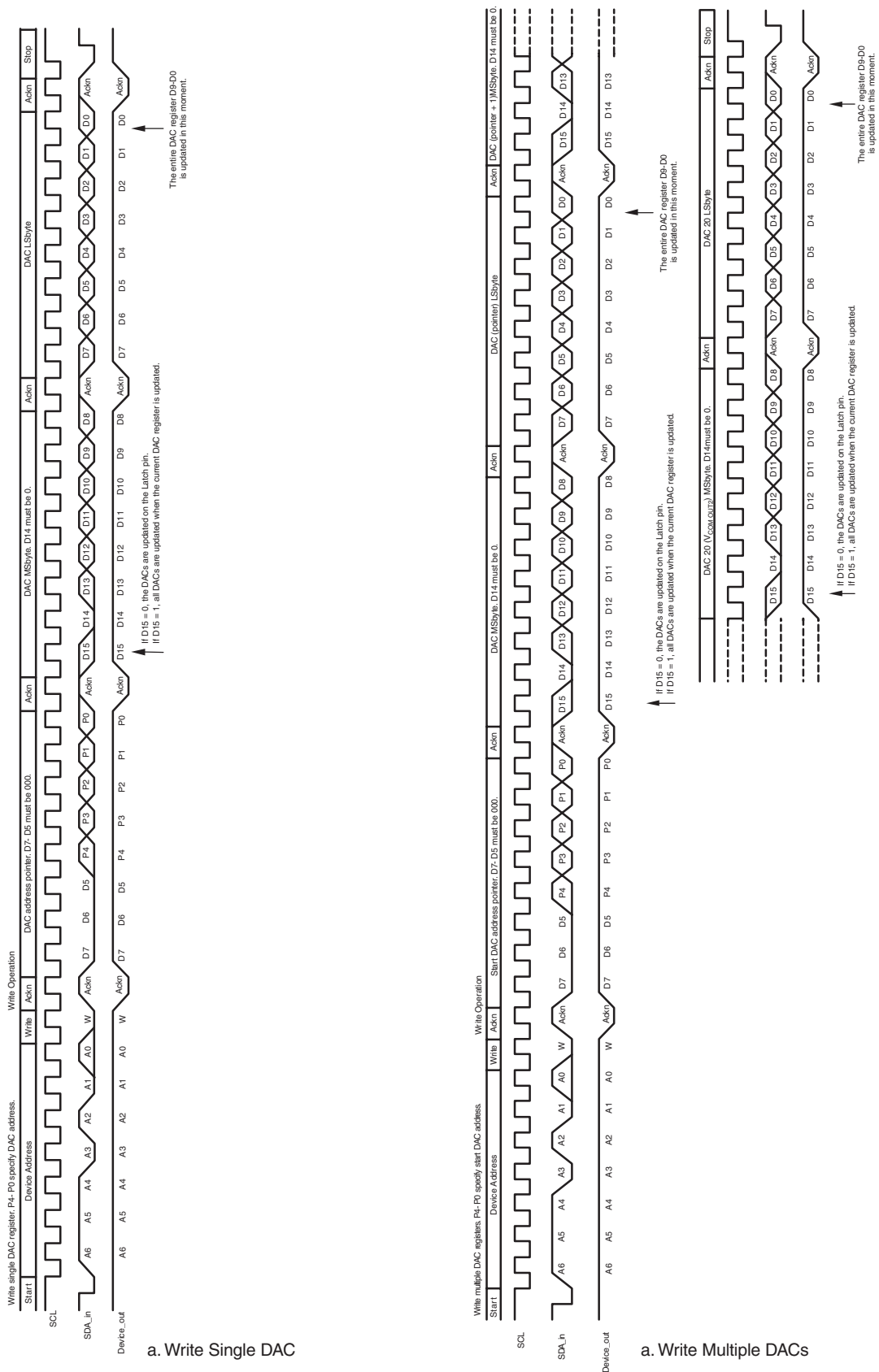

Figure 9. Timing Diagram for Write DAC Register

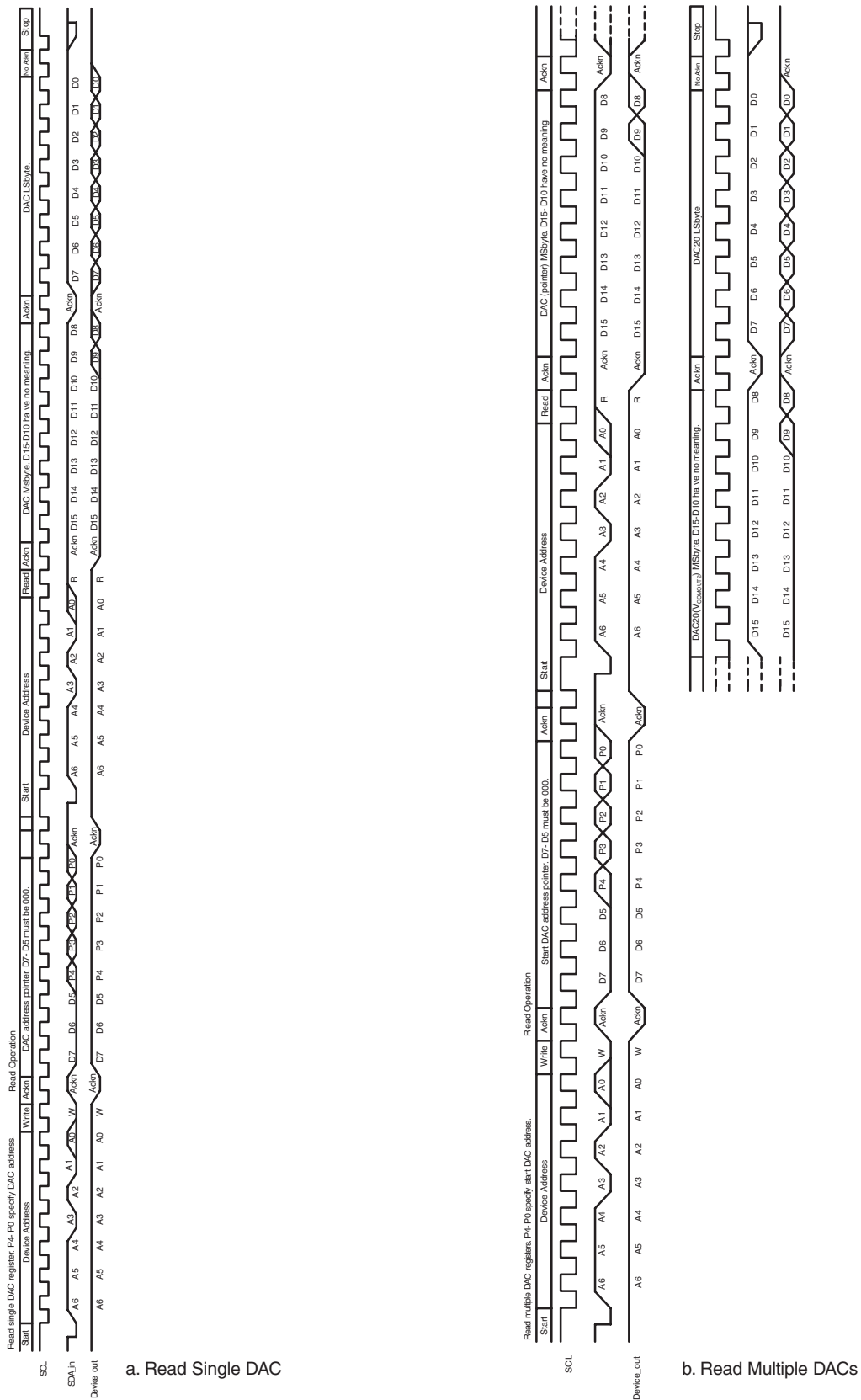

Figure 10. Timing Diagram for Read DAC Register

REPLACEMENT OF TRADITIONAL GAMMA BUFFER

Traditional gamma buffers rely on a resistor string (often using expensive 0.1% resistors) to set the gamma voltages. During development, the optimization of these gamma voltages can be time-consuming. Programming these gamma voltages with the BUF20800-Q1 can significantly reduce the time required for gamma voltage optimization. The final gamma values can be written into an external EEPROM to replace a traditional gamma buffer solution. During power-up of the LCD panel, the timing controller reads the EEPROM and loads the values into the BUF20800-Q1 to generate the desired gamma voltages. Figure 11a shows the traditional resistor string; Figure 11b shows the more efficient alternative method using the BUF20800-Q1.

BUF20800-Q1 uses the most advanced high-voltage CMOS process available today, which allows it to be competitive with traditional gamma buffers.

This technique offers significant advantages:

- It shortens development time significantly.
- It allows demonstration of various gamma curves to LCD monitor makers by simply uploading a different set of gamma values.
- It allows simple adjustment of gamma curves during production to accommodate changes in the panel manufacturing process or end-customer requirements.
- It decreases cost and space.

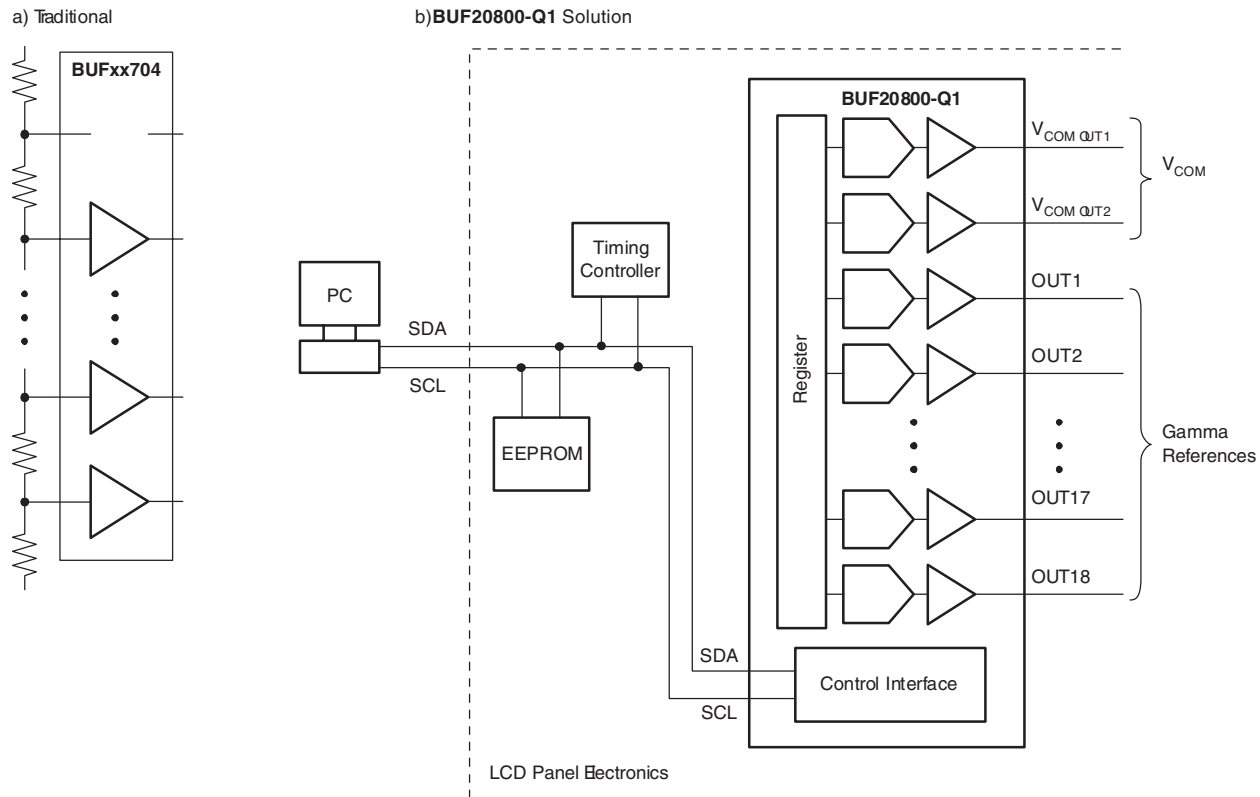

Figure 11. Replacement of the Traditional Gamma Buffer

PROGRAMMABLE V_{COM}

The V_{COM} channels of the BUF20800-Q1 can swing to 2V from the positive supply rail while sourcing 50 mA and to 1 V above the negative rail while sinking 50 mA (see Figure 4, typical characteristic *Output Voltage vs Output Current*). To store the gamma and the V_{COM} values, an external EEPROM is required. During power-up of the LCD panel, the timing controller can then read the EEPROM and load the values into the BUF20800-Q1 to generate the desired V_{COM} voltages, as illustrated in Figure 11 and Figure 12. The V_{COM} channels can be programmed independently from the gamma channels.

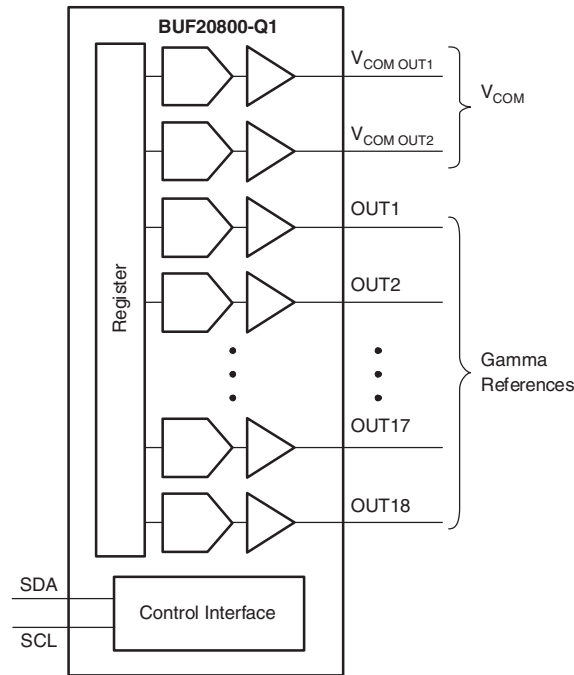

Figure 12. BUF20800-Q1 Used for Programmable V_{COM}

REFH AND REFL INPUT RANGE

Best performance and output swing range of the BUF20800-Q1 are achieved by applying REFH and REFL voltages that are slightly below the power-supply voltages. Most specifications have been tested at $REFH = V_s - 200mV$ and $REFL = GND + 200mV$. The REFH internal buffer is designed to swing very closely to V_s and the REFL internal buffer to GND. However, there is a finite limit on how close they can swing before saturating. To avoid saturation of the internal REFH and REFL buffers, the REFH voltage should not be greater than $V_s - 100mV$ and REFL voltage should not be lower than $GND + 100mV$. Figure 13 shows the swing capability of the REFH and REFL buffers.

The other consideration when trying to maximize the output swing capability of the gamma buffers is the limitation in the swing range of output buffers (OUT1–18, V_{COM1} , and V_{COM2}), which depends on the load current. A typical load in the LCD application is 5–10mA. For example, if OUT1 is sourcing 10mA, the swing is typically limited to about $V_s - 200mV$. The same applies to OUT18, which typically limits at $GND + 200mV$ when sinking 10mA. An increase in output swing can only be achieved for much lighter loads. For example, a 3mA load typically allows the swing to be increased to approximately $V_s - 100mV$ and $GND + 100mV$.

Connecting REFH directly to V_s and REFL directly to GND does not damage the BUF20800-Q1. As discussed above however, the output stages of the REFH and REFL buffers will saturate. This condition is not desirable and can result in a small error in the measured output voltages of OUT1–18, V_{COM1} , and V_{COM2} . As described above, this method of connecting REFH and REL does not help to maximize the output swing capability.

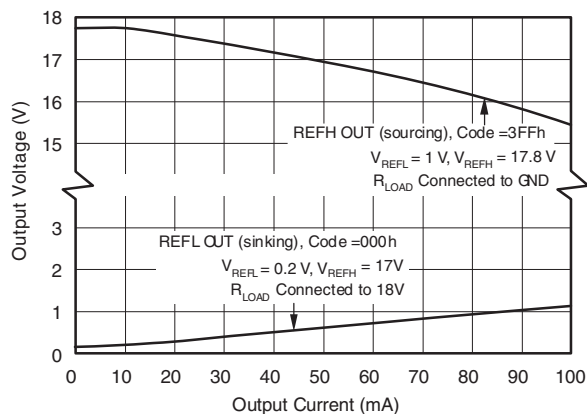

Figure 13. Reference Buffer Output Voltage vs Output Current

CONFIGURATION FOR 20 GAMMA CHANNELS

The V_{COM} outputs can be used as additional gamma references in order to achieve two additional gamma channels (20 total). The V_{COM} outputs will behave the same as the OUT1–9 outputs when sourcing or sinking smaller currents (see Figure 4). The V_{COM} outputs are better able to swing to the positive rail than to the negative rail. Therefore, it is better to use the V_{COM} outputs for higher reference voltages, as shown in Figure 14.

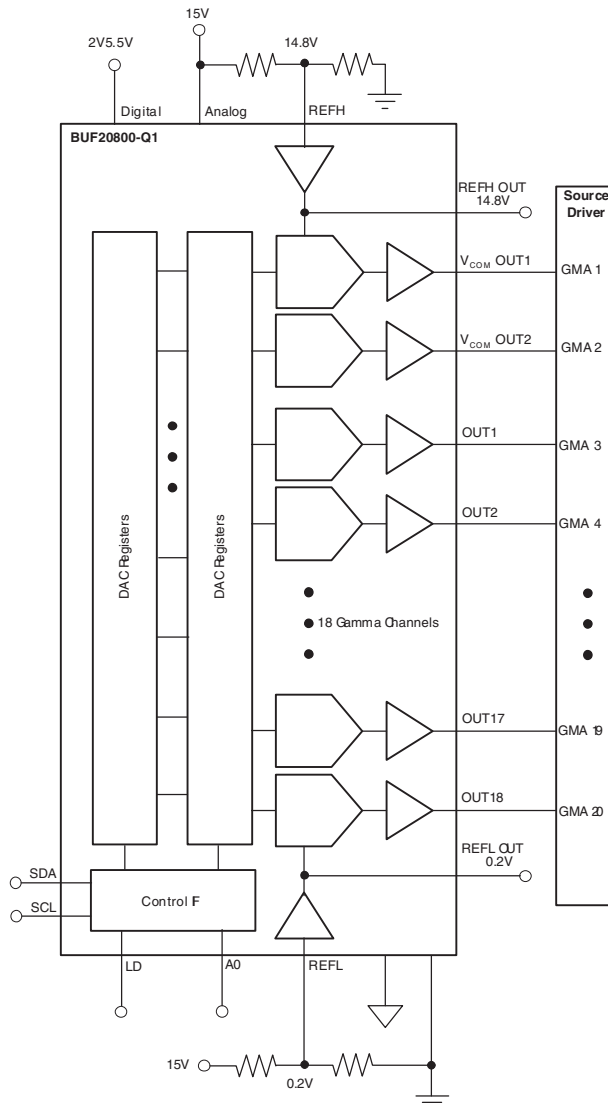

Figure 14. 20 Gamma Channel Solution – Two V_{COM} Channels Used as Additional Gamma Channels

CONFIGURATION FOR 22 GAMMA CHANNELS

In addition to the V_{COM} outputs, the REFH and REFL OUT outputs can also be used as fixed gamma references. The output voltage will be set by the REFH and REFL input voltages, respectively. Therefore, REFH OUT should be used for the highest voltage gamma reference, and REFL OUT for the lowest voltage gamma reference. A 22-channel solution can be created by using all 18 outputs, the two V_{COM} outputs, and both REFH/L OUT outputs for gamma references—see Figure 15. However, the REFH and REFL OUT buffers were designed to only drive light loads on the order of 5–10mA. Driving capacitive loads is not recommended with these buffers. In addition, the REFH and REFL buffers must not be allowed to saturate from sourcing/sinking too much current from REFH OUT or REFL OUT. Saturation of the REFH and REFL buffers results in errors in the voltages of OUT1–18 and V_{COM} OUT1–2. The BUF01900 can be used to provide a programmable V_{COM} output.

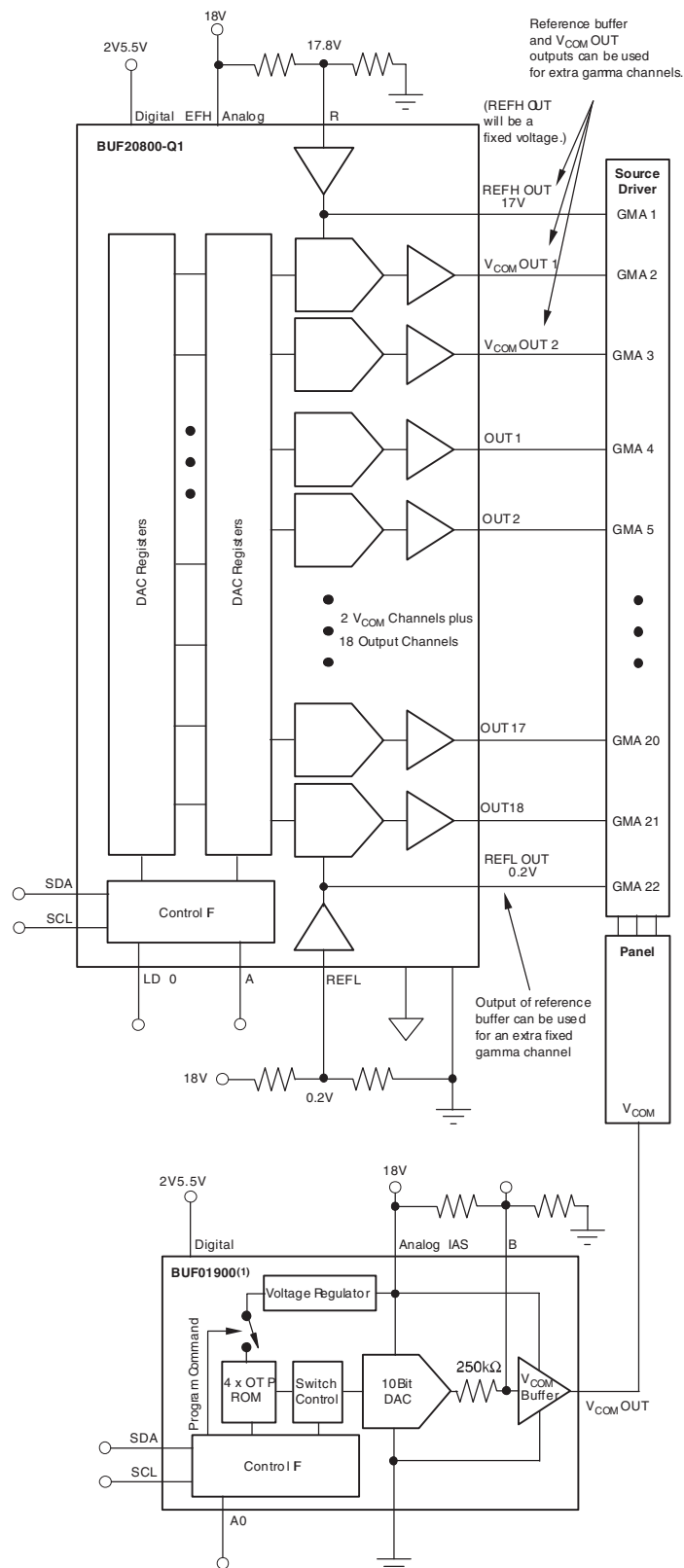

Figure 15. 22-Channel Gamma Solution

DYNAMIC GAMMA CONTROL

Dynamic gamma control is a technique used to improve the picture quality in LCD TV applications. The brightness in each picture frame is analyzed and the gamma curves are adjusted on a frame-by-frame basis. The gamma curves are typically updated during the short vertical blanking period in the video signal. Figure 16 shows a block diagram using the BUF20800-Q1 for dynamic gamma control and V_{COM} output.

The BUF20800-Q1 is ideally suited for rapidly changing the gamma curves because of its unique topology:

- double register input structure to the DAC;
- fast serial interface;
- simultaneous updating of all DACs by software. See the [Read/Write Operations](#) to write to all registers and the [Output Latch](#) sections.

The double register input structure saves programming time by allowing updated DAC values to be pre-loaded into the first register bank. Storage of this data can occur while a picture is still being displayed. Because the data are only stored into the first register bank, the DAC output values remain unchanged—the display is unaffected. During the vertical sync period, the DAC outputs (and therefore, the gamma voltages) can be quickly updated either by using an additional control line connected to the LD pin, or through software—writing a ‘1’ in bit 15 of any DAC register. For the details on the operation of the double register input structure, see the [Output Latch](#) section.

Example: Update all 18 gamma registers simultaneously via software.

Step 1: Check if LD pin is placed in HIGH state.

Step 2: Write DAC Registers 1–18 with bit 15 always ‘0’.

Step 3: Write any DAC register a second time with identical data. Make sure that bit 15 is ‘1’. All DAC channels will be updated simultaneously after receiving the last bit of data. (Note: this step may be eliminated by setting bit 15 of DAC 18 to ‘1’ in the previous step.)

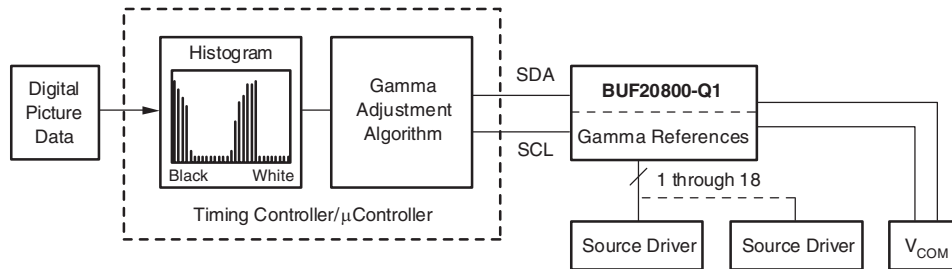

Figure 16. Dynamic Gamma Control

TOTAL TI PANEL SOLUTION

In addition to the BUF20800-Q1 programmable voltage reference, TI offers a complete set of ICs for the LCD panel market, including gamma correction buffers, various power-supply solutions, and audio power solutions. See Figure 17 for the total IC solution from TI.

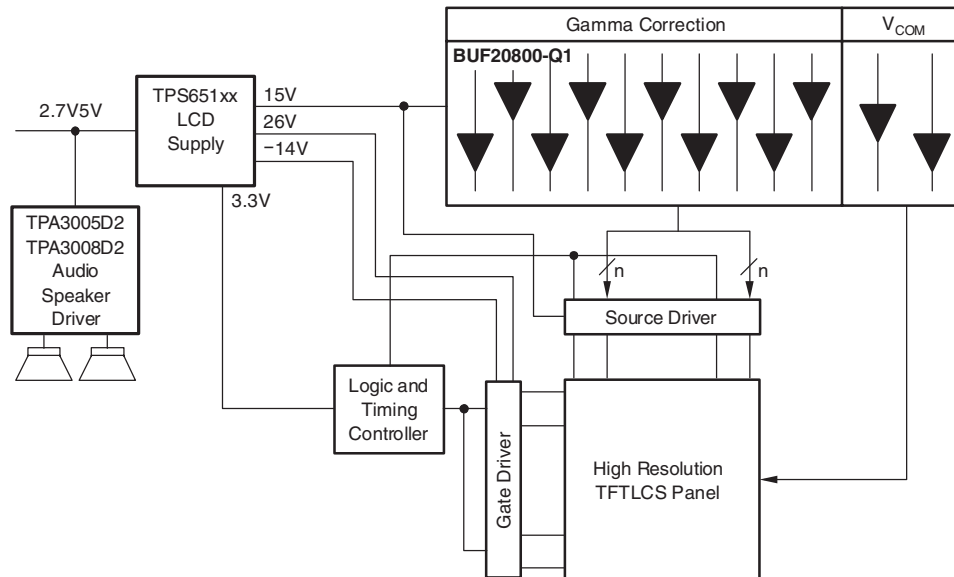

Figure 17. TI LCD Solution

THE BUF20800-Q1 IN INDUSTRIAL APPLICATIONS

The wide supply range, high output current, and very low cost make the BUF20800-Q1 attractive for a range of medium accuracy industrial applications such as programmable power supplies, multi-channel data-acquisition systems, data loggers, sensor excitation and linearization, power-supply generation, and other uses. Each DAC channel features 1LSB DNL and INL.

Many systems require different levels of biasing and power supply for various components as well as sensor excitation, control-loop set-points, voltage outputs, current outputs, and other functions. The BUF20800-Q1, with its 20 total programmable DAC channels, provides great flexibility to the entire system by allowing the designer to change all these parameters via software.

Figure 18 provides various ideas on how the BUF20800-Q1 can be used in applications. A micro-controller with two-wire serial interface controls the various DACs of the BUF20800-Q1. The BUF20800-Q1 can be used for:

- sensor excitation
- programmable bias/reference voltages
- variable power-supplies
- high-current voltage output
- 4-20mA output
- set-point generators for control loops

NOTE: The output voltages of the BUF20800-Q1 DACs will be set to $(V_{REFH} - V_{REFL})/2$ at power-up or reset.

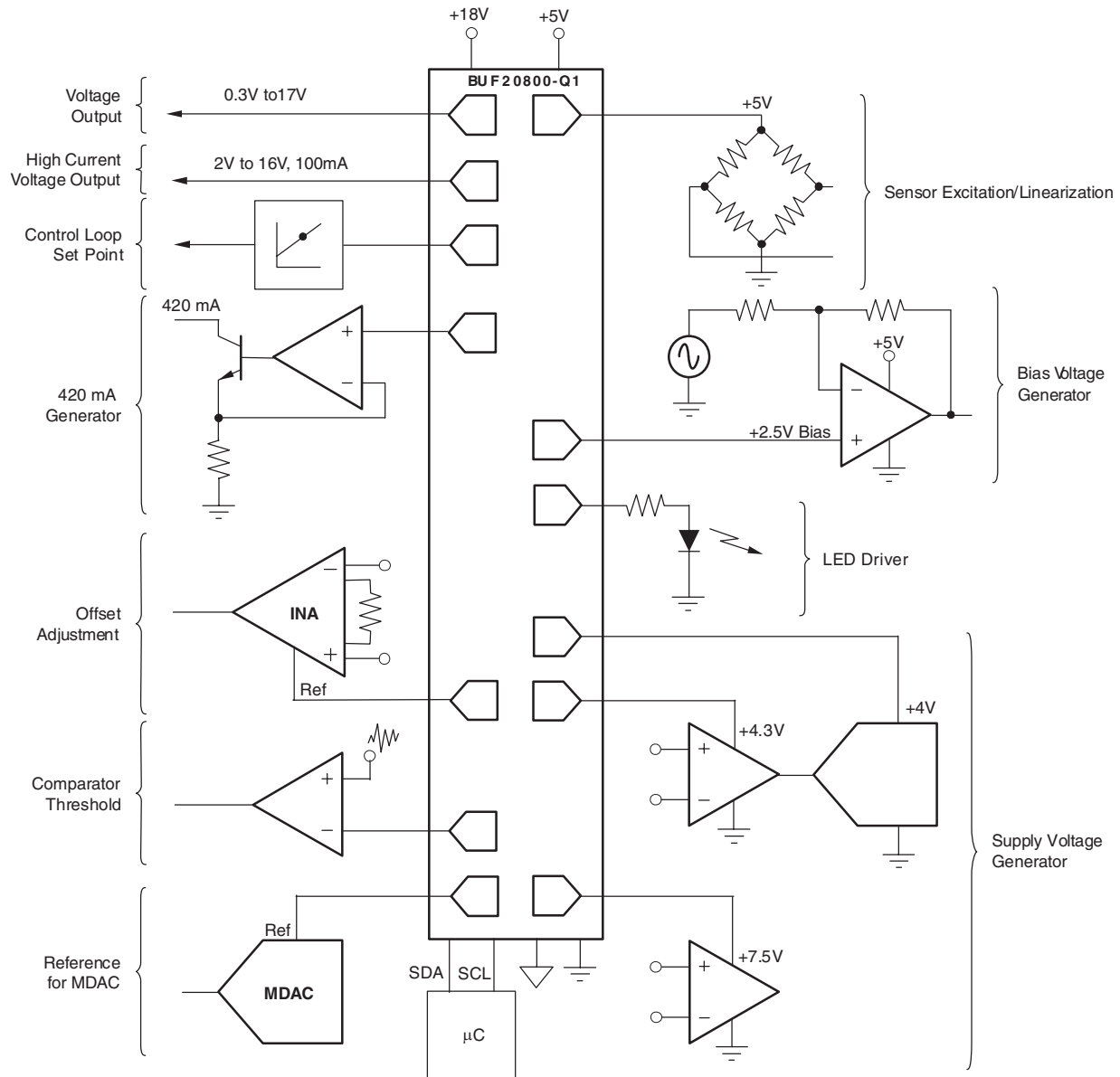

Figure 18. Industrial Applications for the BUF20800-Q1

EVALUATION BOARD AND SOFTWARE

An evaluation board is available for the BUF20800-Q1. The evaluation board features easy-to-use software that allows individual channel voltages to be set (see [Figure 19](#)). Configurations can be quickly evaluated to determine optimal codes for a given application. Contact your local TI representative for more information regarding the evaluation board.

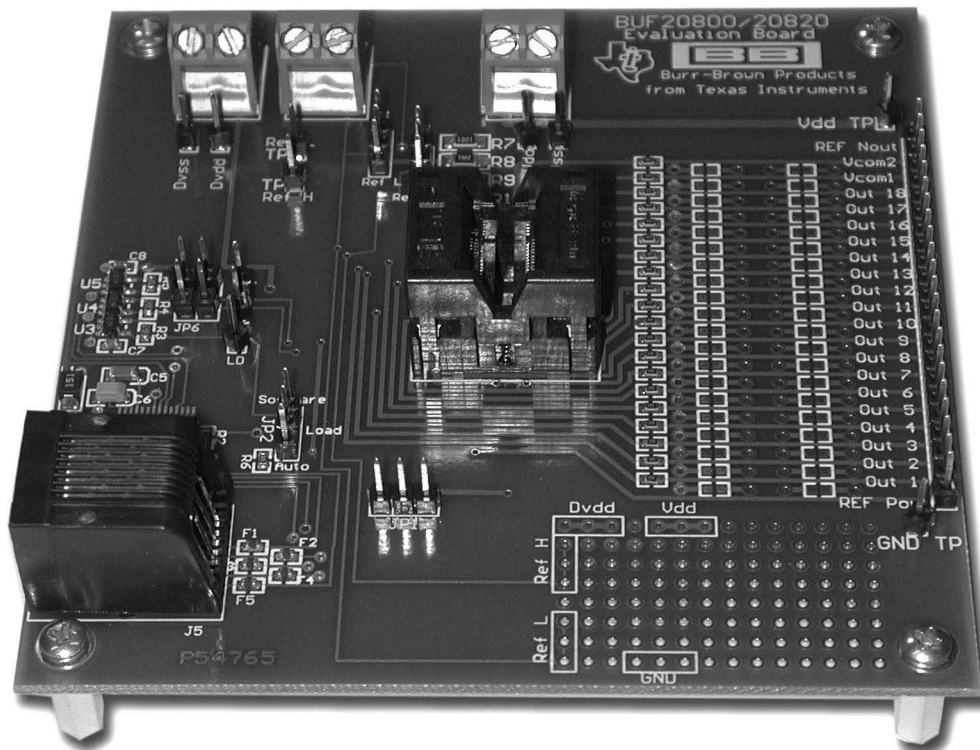

Figure 19. Evaluation Board

GENERAL PowerPAD DESIGN CONSIDERATIONS

The BUF20800-Q1 is available in a thermally-enhanced PowerPAD package. This package is constructed using a downset leadframe upon which the die is mounted, see [Figure 20\(a\)](#) and [Figure 20\(b\)](#). This arrangement results in the lead frame being exposed as a thermal pad on the underside of the package; see [Figure 20\(c\)](#). This thermal pad has direct thermal contact with the die; thus, excellent thermal performance is achieved by providing a good thermal path away from the thermal pad.

The PowerPAD package allows for both assembly and thermal management in one manufacturing operation. During the surface-mount solder operation (when the leads are being soldered), the thermal pad must be soldered to a copper area underneath the package. Through the use of thermal paths within this copper area, heat can be conducted away from the package into either a ground plane or other heat-dissipating device. **Soldering the PowerPAD to the printed circuit board (PCB) is always required, even with applications that have low power dissipation.** This provides the necessary thermal and mechanical connection between the lead frame die pad and the PCB.

The PowerPAD must be connected to the most negative supply voltage on the device, GND_A and GND_D .

1. Prepare the PCB with a top-side etch pattern. There should be etching for the leads as well as etch for the thermal pad.
2. Place recommended holes in the area of the thermal pad. Ideal thermal land size and thermal via patterns for the HTSSOP-38 DCP package can be seen in the technical brief, *PowerPAD Thermally-Enhanced Package (SLMA002)*, available for download at www.ti.com. These holes should be 13 mils in diameter. Keep them small, so that solder wicking through the holes is not a problem during reflow. An example thermal land pattern mechanical drawing is attached to the end of this data sheet.
3. Additional vias may be placed anywhere along the thermal plane outside of the thermal pad area. This helps dissipate the heat generated by the BUF20800-Q1 IC. These additional vias may be larger than the 13-mil diameter vias directly under the thermal pad. They can be larger because they are not in the thermal pad area to be soldered; thus, wicking is not a problem.
4. Connect all holes to the internal plane that is at the same voltage potential as the GND pins.

5. When connecting these holes to the internal plane, do not use the typical web or spoke via connection methodology. Web connections have a high thermal resistance connection that is useful for slowing the heat transfer during soldering operations. This makes the soldering of vias that have plane connections easier. In this application, however, low thermal resistance is desired for the most efficient heat transfer. Therefore, the holes under the BUF20800-Q1 PowerPAD package should make their connection to the internal plane with a complete connection around the entire circumference of the plated-through hole.
6. The top-side solder mask should leave the terminals of the package and the thermal pad area with its twelve holes exposed. The bottom-side solder mask should cover the holes of the thermal pad area. This masking prevents solder from being pulled away from the thermal pad area during the reflow process.
7. Apply solder paste to the exposed thermal pad area and all of the IC terminals.
8. With these preparatory steps in place, the BUF20800-Q1 IC is simply placed in position and run through the solder reflow operation as any standard surfacemount component. This preparation results in a properly installed part.

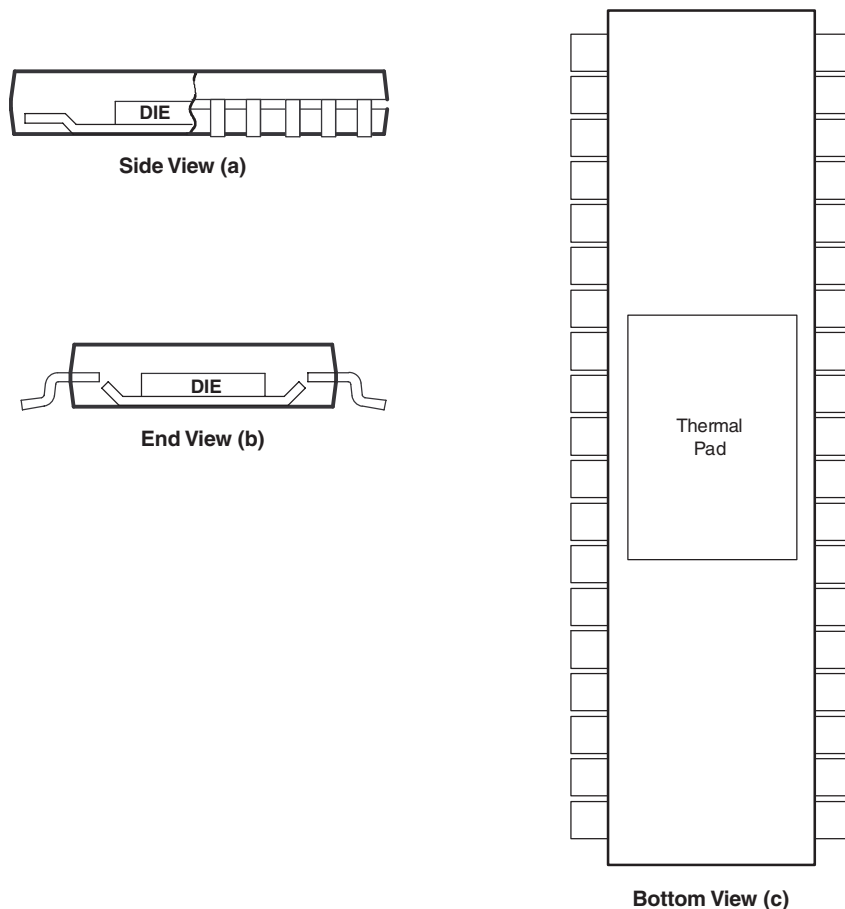

The thermal pad is electrically isolated from all terminals in the package.

Figure 20. Views of Thermally-Enhanced DCP Package

For a given θ_{JA} (listed in the [Electrical Characteristics](#) table), the maximum power dissipation is shown in [Figure 21](#), and is calculated by [Equation 3](#):

$$P_D = \left(\frac{T_{MAX} - T_A}{\theta_{JA}} \right) \quad (3)$$

Where:

P_D = maximum power dissipation (W)

T_{MAX} = absolute maximum junction temperature (+125°C)

T_A = free-ambient air temperature (°C)

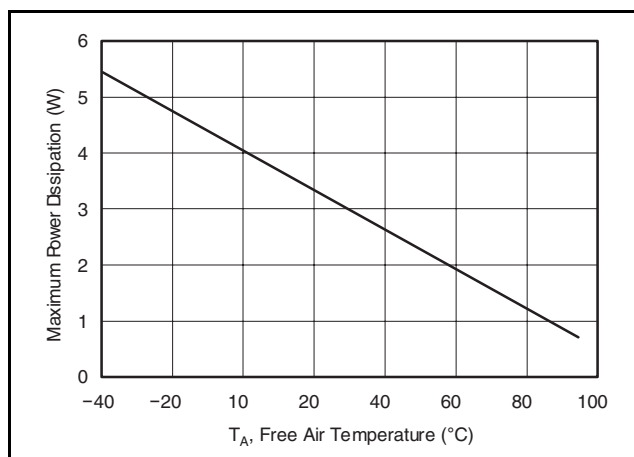

Figure 21. Maximum Power Dissipation vs Free-Air Temperature (with PowerPAD soldered down)

PACKAGING INFORMATION

| Orderable Device | Status ⁽¹⁾ | Package Type | Package Drawing | Pins | Package Qty | Eco Plan ⁽²⁾ | Lead/ Ball Finish | MSL Peak Temp ⁽³⁾ | Samples (Requires Login) |
|------------------|-----------------------|--------------|-----------------|------|-------------|----------------------------|----------------------|------------------------------|-----------------------------|
| BUF20800ATDCPRQ1 | ACTIVE | HTSSOP | DCP | 38 | 2000 | Green (RoHS & no Sb/Br) | CU NIPDAU | Level-3-260C-168 HR | |

⁽¹⁾ The marketing status values are defined as follows:

ACTIVE: Product device recommended for new designs.

LIFEBUY: TI has announced that the device will be discontinued, and a lifetime-buy period is in effect.

NRND: Not recommended for new designs. Device is in production to support existing customers, but TI does not recommend using this part in a new design.

PREVIEW: Device has been announced but is not in production. Samples may or may not be available.

OBSOLETE: TI has discontinued the production of the device.

⁽²⁾ Eco Plan - The planned eco-friendly classification: Pb-Free (RoHS), Pb-Free (RoHS Exempt), or Green (RoHS & no Sb/Br) - please check <http://www.ti.com/productcontent> for the latest availability information and additional product content details.

TBD: The Pb-Free/Green conversion plan has not been defined.

Pb-Free (RoHS): TI's terms "Lead-Free" or "Pb-Free" mean semiconductor products that are compatible with the current RoHS requirements for all 6 substances, including the requirement that lead not exceed 0.1% by weight in homogeneous materials. Where designed to be soldered at high temperatures, TI Pb-Free products are suitable for use in specified lead-free processes.

Pb-Free (RoHS Exempt): This component has a RoHS exemption for either 1) lead-based flip-chip solder bumps used between the die and package, or 2) lead-based die adhesive used between the die and leadframe. The component is otherwise considered Pb-Free (RoHS compatible) as defined above.

Green (RoHS & no Sb/Br): TI defines "Green" to mean Pb-Free (RoHS compatible), and free of Bromine (Br) and Antimony (Sb) based flame retardants (Br or Sb do not exceed 0.1% by weight in homogeneous material)

⁽³⁾ MSL, Peak Temp. -- The Moisture Sensitivity Level rating according to the JEDEC industry standard classifications, and peak solder temperature.

Important Information and Disclaimer: The information provided on this page represents TI's knowledge and belief as of the date that it is provided. TI bases its knowledge and belief on information provided by third parties, and makes no representation or warranty as to the accuracy of such information. Efforts are underway to better integrate information from third parties. TI has taken and continues to take reasonable steps to provide representative and accurate information but may not have conducted destructive testing or chemical analysis on incoming materials and chemicals. TI and TI suppliers consider certain information to be proprietary, and thus CAS numbers and other limited information may not be available for release.

In no event shall TI's liability arising out of such information exceed the total purchase price of the TI part(s) at issue in this document sold by TI to Customer on an annual basis.

OTHER QUALIFIED VERSIONS OF BUF20800-Q1 :

- Catalog: [BUF20800](#)

NOTE: Qualified Version Definitions:

- Catalog - TI's standard catalog product

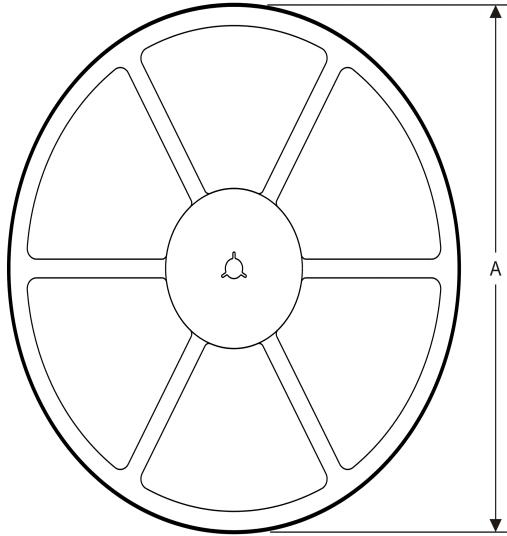
TAPE AND REEL INFORMATION
REEL DIMENSIONS

TAPE DIMENSIONS

| | |
|----|---|
| A0 | Dimension designed to accommodate the component width |
| B0 | Dimension designed to accommodate the component length |
| K0 | Dimension designed to accommodate the component thickness |
| W | Overall width of the carrier tape |
| P1 | Pitch between successive cavity centers |

TAPE AND REEL INFORMATION

*All dimensions are nominal

| Device | Package Type | Package Drawing | Pins | SPQ | Reel Diameter (mm) | Reel Width W1 (mm) | A0 (mm) | B0 (mm) | K0 (mm) | P1 (mm) | W (mm) | Pin1 Quadrant |
|------------------|--------------|-----------------|------|------|--------------------|--------------------|---------|---------|---------|---------|--------|---------------|
| BUF20800ATDCPRQ1 | HTSSOP | DCP | 38 | 2000 | 330.0 | 16.4 | 6.9 | 10.2 | 1.8 | 12.0 | 16.0 | Q1 |

TAPE AND REEL BOX DIMENSIONS



*All dimensions are nominal

| Device | Package Type | Package Drawing | Pins | SPQ | Length (mm) | Width (mm) | Height (mm) |
|------------------|--------------|-----------------|------|------|-------------|------------|-------------|
| BUF20800ATDCPRQ1 | HTSSOP | DCP | 38 | 2000 | 367.0 | 367.0 | 38.0 |

DCP (R-PDSO-G**) 30 PIN SHOWN

PowerPAD™ PLASTIC SMALL-OUTLINE PACKAGE

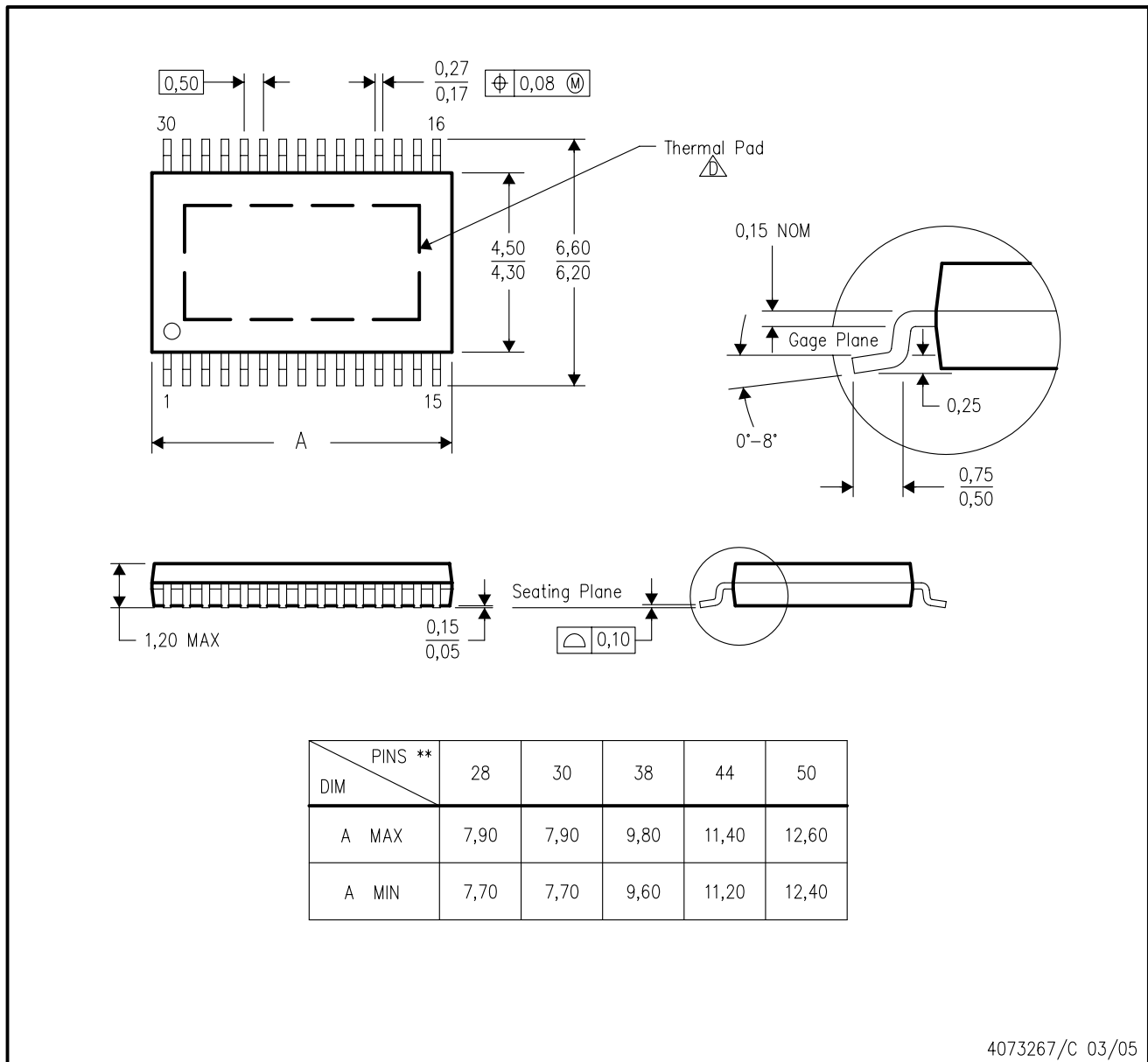

4073267/C 03/05

- NOTES:
- A. All linear dimensions are in millimeters.
 - B. This drawing is subject to change without notice.
 - C. Body dimensions do not include mold flash or protrusions, mold flash not to exceed 0.15mm.
 - D. This package is designed to be soldered to a thermal pad on the board. Refer to Technical Brief, PowerPAD Thermally Enhanced Package, Texas Instruments Literature No. SLMA002 for information regarding recommended board layout. This document is available at www.ti.com. See the product data sheet for details regarding the exposed thermal pad dimensions.
 - E. Falls within JEDEC MO-153

PowerPAD is a trademark of Texas Instruments.

THERMAL INFORMATION

This PowerPAD™ package incorporates an exposed thermal pad that is designed to be attached to a printed circuit board (PCB). The thermal pad must be soldered directly to the PCB. After soldering, the PCB can be used as a heatsink. In addition, through the use of thermal vias, the thermal pad can be attached directly to the appropriate copper plane shown in the electrical schematic for the device, or alternatively, can be attached to a special heatsink structure designed into the PCB. This design optimizes the heat transfer from the integrated circuit (IC).

For additional information on the PowerPAD package and how to take advantage of its heat dissipating abilities, refer to Technical Brief, PowerPAD Thermally Enhanced Package, Texas Instruments Literature No. SLMA002 and Application Brief, PowerPAD Made Easy, Texas Instruments Literature No. SLMA004. Both documents are available at www.ti.com.

The exposed thermal pad dimensions for this package are shown in the following illustration.

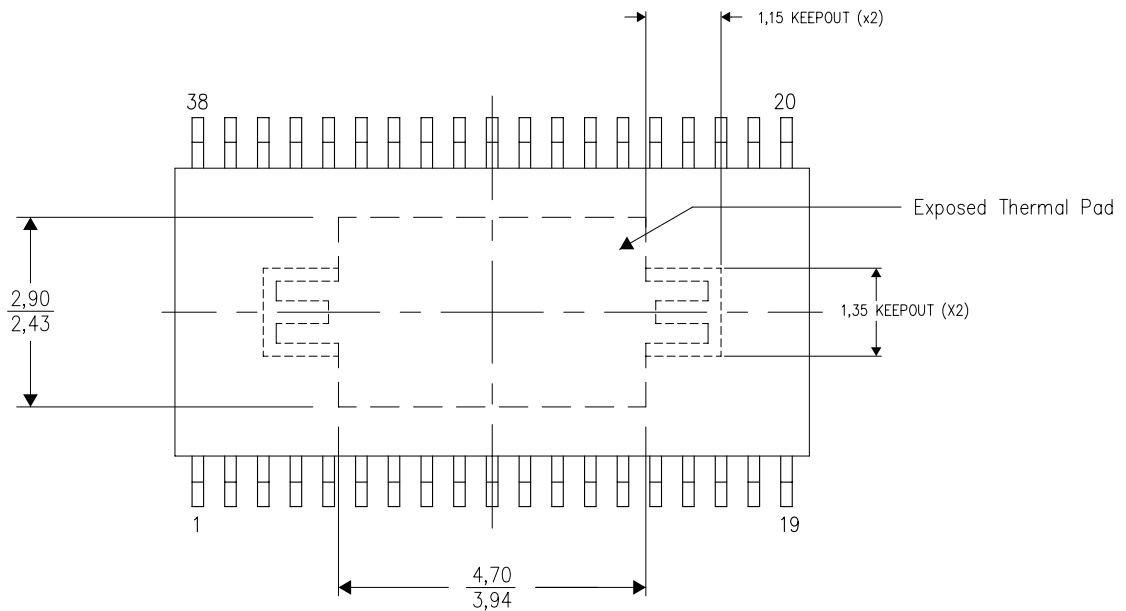

Top View

NOTE: All linear dimensions are in millimeters

Exposed Thermal Pad Dimensions

DCP (R-PDSO-G38) PowerPAD™

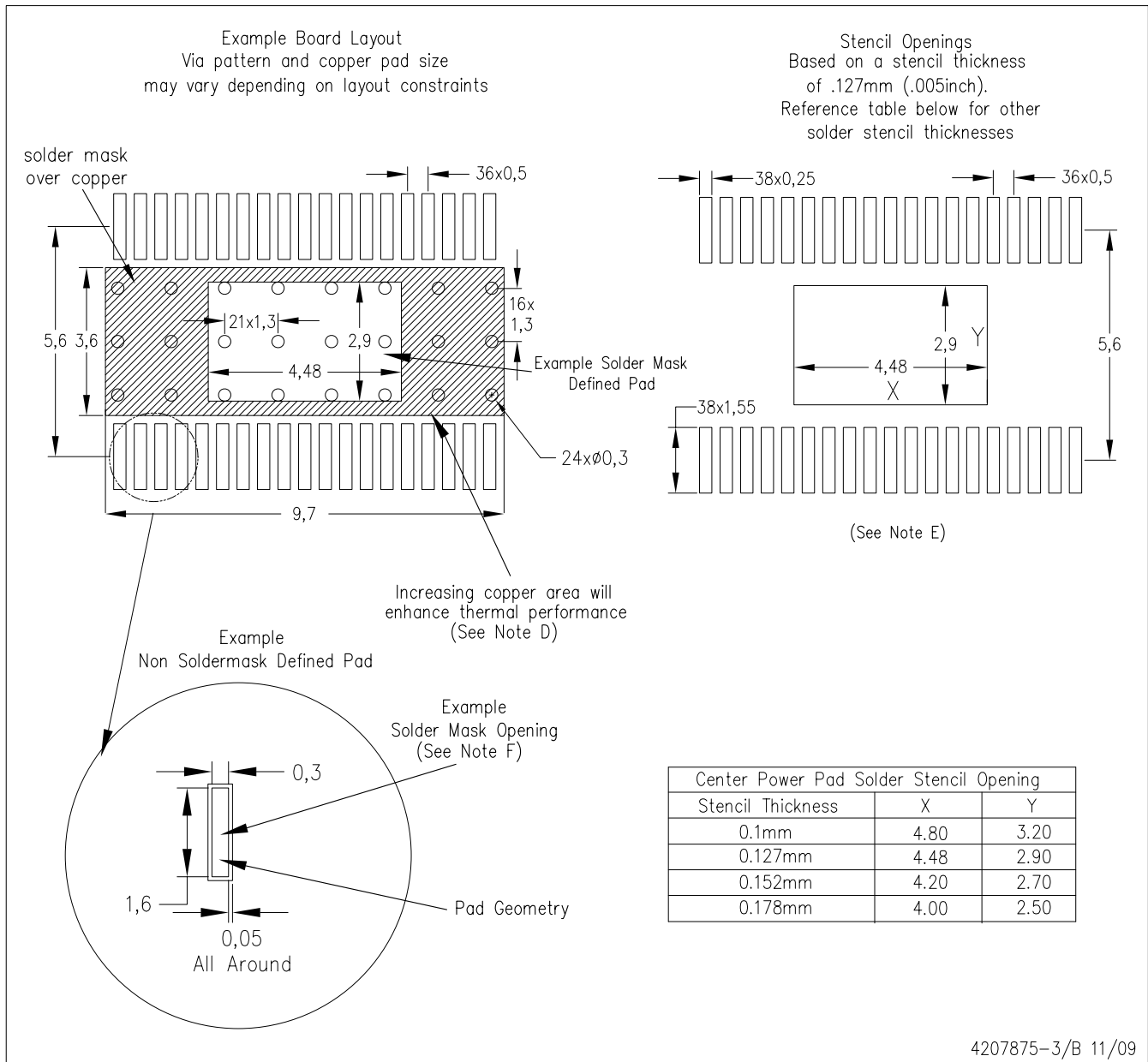

- NOTES:
- All linear dimensions are in millimeters.
 - This drawing is subject to change without notice.
 - Customers should place a note on the circuit board fabrication drawing not to alter the center solder mask defined pad.
 - This package is designed to be soldered to a thermal pad on the board. Refer to Technical Brief, PowerPad Thermally Enhanced Package, Texas Instruments Literature No. SLMA002, SLMA004, and also the Product Data Sheets for specific thermal information, via requirements, and recommended board layout. These documents are available at www.ti.com <<http://www.ti.com>>. Publication IPC-7351 is recommended for alternate designs.
 - Laser cutting apertures with trapezoidal walls and also rounding corners will offer better paste release. Customers should contact their board assembly site for stencil design recommendations. Example stencil design based on a 50% volumetric metal load solder paste. Refer to IPC-7525 for other stencil recommendations.
 - Customers should contact their board fabrication site for solder mask tolerances between and around signal pads.

PowerPAD is a trademark of Texas Instruments.

IMPORTANT NOTICE

Texas Instruments Incorporated and its subsidiaries (TI) reserve the right to make corrections, enhancements, improvements and other changes to its semiconductor products and services per JESD46C and to discontinue any product or service per JESD48B. Buyers should obtain the latest relevant information before placing orders and should verify that such information is current and complete. All semiconductor products (also referred to herein as "components") are sold subject to TI's terms and conditions of sale supplied at the time of order acknowledgment.

TI warrants performance of its components to the specifications applicable at the time of sale, in accordance with the warranty in TI's terms and conditions of sale of semiconductor products. Testing and other quality control techniques are used to the extent TI deems necessary to support this warranty. Except where mandated by applicable law, testing of all parameters of each component is not necessarily performed.

TI assumes no liability for applications assistance or the design of Buyers' products. Buyers are responsible for their products and applications using TI components. To minimize the risks associated with Buyers' products and applications, Buyers should provide adequate design and operating safeguards.

TI does not warrant or represent that any license, either express or implied, is granted under any patent right, copyright, mask work right, or other intellectual property right relating to any combination, machine, or process in which TI components or services are used. Information published by TI regarding third-party products or services does not constitute a license to use such products or services or a warranty or endorsement thereof. Use of such information may require a license from a third party under the patents or other intellectual property of the third party, or a license from TI under the patents or other intellectual property of TI.

Reproduction of significant portions of TI information in TI data books or data sheets is permissible only if reproduction is without alteration and is accompanied by all associated warranties, conditions, limitations, and notices. TI is not responsible or liable for such altered documentation. Information of third parties may be subject to additional restrictions.

Resale of TI components or services with statements different from or beyond the parameters stated by TI for that component or service voids all express and any implied warranties for the associated TI component or service and is an unfair and deceptive business practice. TI is not responsible or liable for any such statements.

Buyer acknowledges and agrees that it is solely responsible for compliance with all legal, regulatory and safety-related requirements concerning its products, and any use of TI components in its applications, notwithstanding any applications-related information or support that may be provided by TI. Buyer represents and agrees that it has all the necessary expertise to create and implement safeguards which anticipate dangerous consequences of failures, monitor failures and their consequences, lessen the likelihood of failures that might cause harm and take appropriate remedial actions. Buyer will fully indemnify TI and its representatives against any damages arising out of the use of any TI components in safety-critical applications.

In some cases, TI components may be promoted specifically to facilitate safety-related applications. With such components, TI's goal is to help enable customers to design and create their own end-product solutions that meet applicable functional safety standards and requirements. Nonetheless, such components are subject to these terms.

No TI components are authorized for use in FDA Class III (or similar life-critical medical equipment) unless authorized officers of the parties have executed a special agreement specifically governing such use.

Only those TI components which TI has specifically designated as military grade or "enhanced plastic" are designed and intended for use in military/aerospace applications or environments. Buyer acknowledges and agrees that any military or aerospace use of TI components which have **not** been so designated is solely at the Buyer's risk, and that Buyer is solely responsible for compliance with all legal and regulatory requirements in connection with such use.

TI has specifically designated certain components which meet ISO/TS16949 requirements, mainly for automotive use. Components which have not been so designated are neither designed nor intended for automotive use; and TI will not be responsible for any failure of such components to meet such requirements.

Products

| | |
|------------------------|--|
| Audio | www.ti.com/audio |
| Amplifiers | amplifier.ti.com |
| Data Converters | dataconverter.ti.com |
| DLP® Products | www.dlp.com |
| DSP | dsp.ti.com |
| Clocks and Timers | www.ti.com/clocks |
| Interface | interface.ti.com |
| Logic | logic.ti.com |
| Power Mgmt | power.ti.com |
| Microcontrollers | microcontroller.ti.com |
| RFID | www.ti-rfid.com |
| OMAP Mobile Processors | www.ti.com/omap |
| Wireless Connectivity | www.ti.com/wirelessconnectivity |

Applications

| | |
|-------------------------------|--|
| Automotive and Transportation | www.ti.com/automotive |
| Communications and Telecom | www.ti.com/communications |
| Computers and Peripherals | www.ti.com/computers |
| Consumer Electronics | www.ti.com/consumer-apps |
| Energy and Lighting | www.ti.com/energy |
| Industrial | www.ti.com/industrial |
| Medical | www.ti.com/medical |
| Security | www.ti.com/security |
| Space, Avionics and Defense | www.ti.com/space-avionics-defense |
| Video and Imaging | www.ti.com/video |

TI E2E Community e2e.ti.com