

Smart High-Side Power Switch

Two Channels: 2 x 30mΩ

Current Sense

Product Summary

| | | | |
|---------------------|------------------|-----------|--------------|
| Operating Voltage | $V_{bb(on)}$ | 5.0...34V | |
| | Active channels: | one | two parallel |
| On-state Resistance | R_{ON} | 30mΩ | 15mΩ |
| Load Current (ISO) | $I_{L(ISO)}$ | 12A | 24A |
| Current Limitation | $I_{L(SCr)}$ | 24A | 24A |

Package

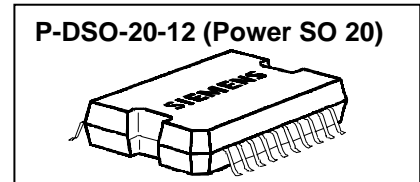

General Description

- N channel vertical power MOSFET with charge pump, ground referenced CMOS compatible input, diagnostic feedback and proportional load current sense monolithically integrated in Smart SIPMOS® technology.
- Providing embedded protective functions

Applications

- μ C compatible high-side power switch with diagnostic feedback for 12V and 24V grounded loads
- All types of resistive, inductive and capacitive loads
- Most suitable for loads with high inrush currents, so as lamps
- Replaces electromechanical relays, fuses and discrete circuits

Basic Functions

- CMOS compatible input
- Undervoltage and overvoltage shutdown with auto-restart and hysteresis
- Fast demagnetization of inductive loads
- Logic ground independent from load ground

Protection Functions

- Short circuit protection
- Overload protection
- Current limitation
- Thermal shutdown
- Overvoltage protection (including load dump) with external resistor
- Reverse battery protection with external resistor
- Loss of ground and loss of V_{bb} protection
- Electrostatic discharge protection (ESD)

Diagnostic Functions

- Proportional load current sense
- Diagnostic feedback with open drain output
- Open load detection in OFF-state with external resistor
- Feedback of thermal shutdown in ON-state

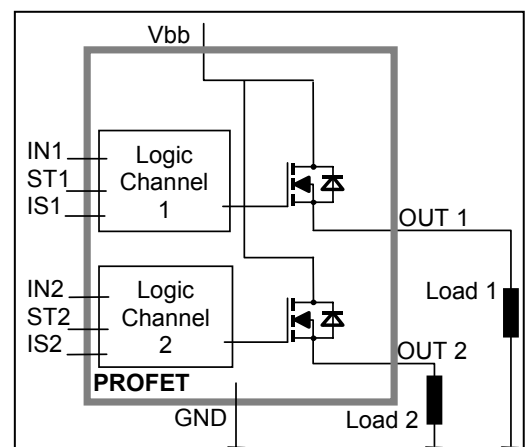

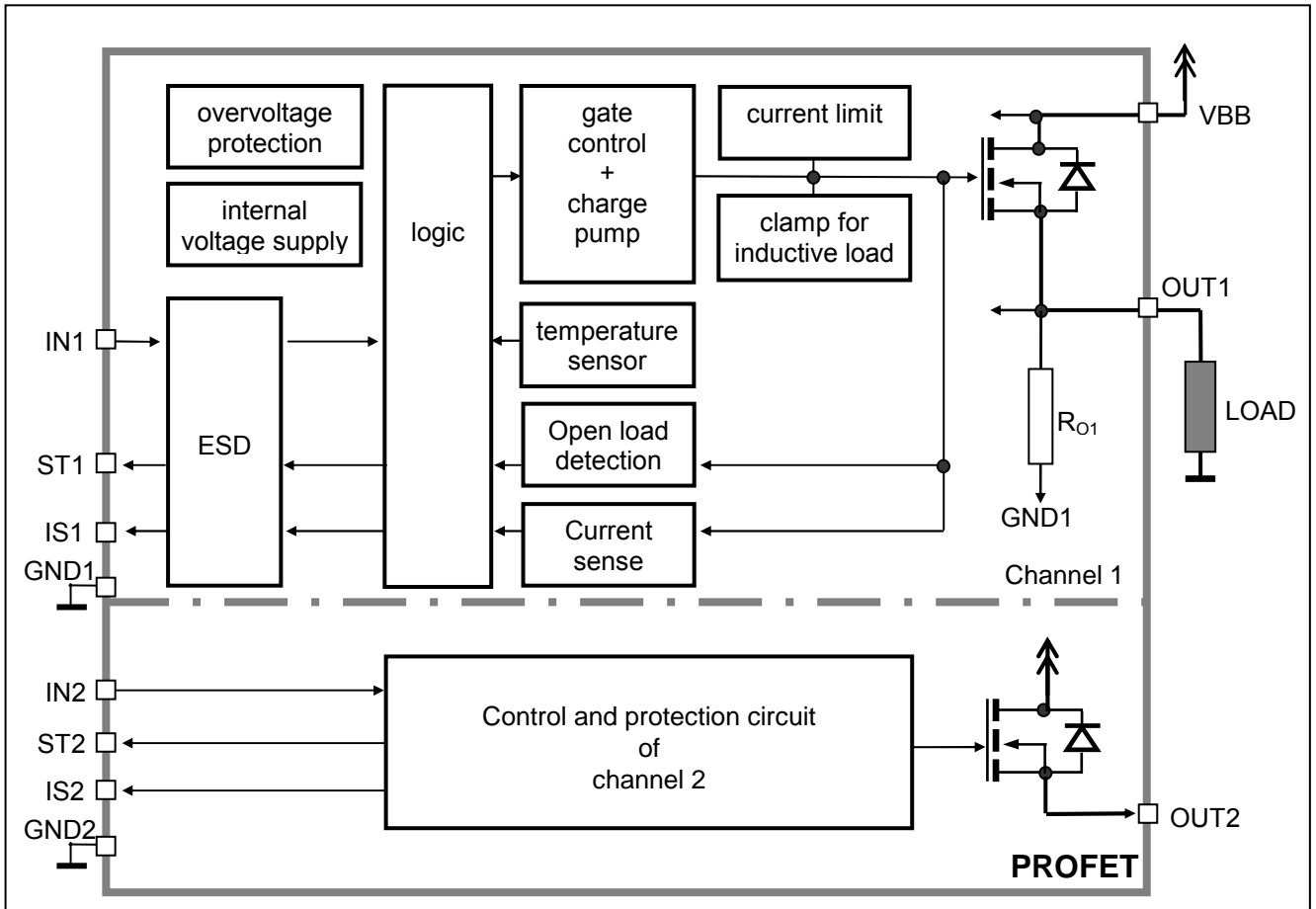
Functional diagram

Pin Definitions and Functions

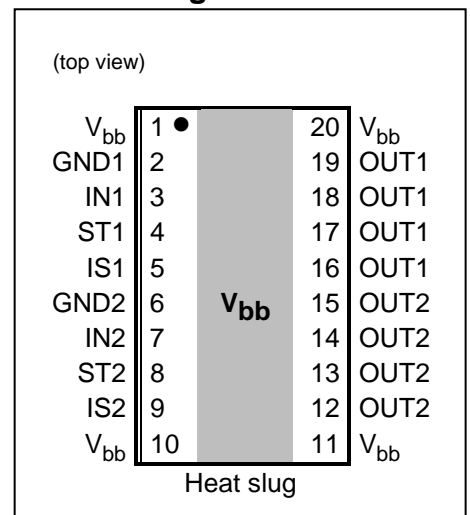
| Pin | Symbol | Function |
|-----------------|----------|--|
| 1,10, 11,12, | V_{bb} | Positive power supply voltage. For high current applications the heat slug should be used as V_{bb} connection. |
| 3 | IN1 | Input 1,2, activates channel 1,2 in case of logic high signal |
| 7 | IN2 | |
| 16,17, 18,19 | OUT1 | Output 1,2, protected high-side power output of channel 1,2. All pins of each output have to be connected in parallel for operation according to this spec (e.g. k_{ijis}). Design the wiring for the max. short circuit current |
| 12,13, 14,15 | OUT2 | |
| 4 | ST1 | Diagnostic feedback 1,2 of channel 1,2 open drain, inverts to input level |
| 8 | ST2 | |
| 2 | GND1 | Ground 1,2 of chip channel 1,2 |
| 6 | GND2 | |
| 5 | IS1 | Sense current output 1,2; proportional to the load current, zero in the case of current limitation of the load current |
| 9 | IS2 | |
| Heatslug | V_{bb} | Positive powersupply voltage. Good way to design a very low thermal resistance. |

Pin configuration

Maximum Ratings at $T_j = 25^\circ\text{C}$ unless otherwise specified

| Parameter | Symbol | Values | Unit |
|---|---|-------------------|------------------|
| Supply voltage (overvoltage protection see page 5) | V_{bb} | 43 | V |
| Supply voltage for full short circuit protection $T_{j,start} = -40 \dots +150^\circ\text{C}$ | V_{bb} | 34 | V |
| Load current (Short-circuit current, see page 5) | I_L | self-limited | A |
| Load dump protection ¹⁾ $V_{LoadDump} = V_A + V_S$, $V_A = 13.5\text{ V}$ $R_l^{2)} = 2\ \Omega$, $t_{dl} = 200\text{ ms}$; IN = low or high, each channel loaded with $R_L = 1.0\ \Omega$, | $V_{Load\ dump}^{3)}$ | 60 | V |
| Operating temperature range | T_j | -40 ... +150 | $^\circ\text{C}$ |
| Storage temperature range | T_{stg} | -55 ... +150 | |
| Power dissipation (DC) ⁴⁾ (all channels active) | $T_a = 25^\circ\text{C}$: $T_a = 85^\circ\text{C}$: P_{tot} | 3.8 2.0 | W |
| Maximal switchable inductance, single pulse $V_{bb} = 12\text{ V}$, $T_{j,start} = 150^\circ\text{C}^{4)}$, $I_L = 4\text{ A}$, $E_{AS} = 1.13\text{ J}$, $0\ \Omega$ one channel: $I_L = 12\text{ A}$, $E_{AS} = 430\text{ mJ}$, $0\ \Omega$ one channel: $I_L = 24\text{ A}$, $E_{AS} = 800\text{ mJ}$, $0\ \Omega$ two parallel channels: see diagrams on page 10 | Z_L | 100 4.4 2.0 | mH |
| Electrostatic discharge capability (ESD) (Human Body Model) IN: ST, IS: out to all other pins shorted: acc. MIL-STD883D, method 3015.7 and ESD assn. std. S5.1-1993 R=1.5k Ω ; C=100pF | V_{ESD} | 1.0 4.0 8.0 | kV |
| Input voltage (DC) | V_{IN} | -10 ... +16 | V |
| Current through input pin (DC) | I_{IN} | ± 2.0 | mA |
| Current through status pin (DC) | I_{ST} | ± 5.0 | |
| Current through current sense pin (DC) see internal circuit diagram page 9 | I_{IS} | ± 14 | |

- 1) Supply voltages higher than $V_{bb(AZ)}$ require an external current limit for the GND and status pins a 150 Ω resistor for the GND connection is recommended.
- 2) R_l = internal resistance of the load dump test pulse generator
- 3) $V_{Load\ dump}$ is set up without the DUT connected to the generator per ISO 7637-1 and DIN 40839
- 4) Device on 50mm*50mm*1.5mm epoxy PCB FR4 with 6cm² (one layer, 70 μm thick) copper area for V_{bb} connection. PCB is vertical without blown air.

Thermal Characteristics

| Parameter and Conditions | Symbol | Values | | | Unit |
|--|------------|--------|-----|-----|------|
| | | min | typ | max | |
| Thermal resistance junction - case | R_{thjs} | -- | -- | 1 | K/W |
| junction - ambient ⁴⁾ | R_{thja} | -- | 37 | -- | |
| each channel: one channel active: all channels active: | | -- | 30 | -- | |

Electrical Characteristics

| Parameter and Conditions, each of the two channels at $T_j = -40\dots+150^\circ\text{C}$, $V_{bb} = 12\text{ V}$ unless otherwise specified | Symbol | Values | | | Unit |
|---|--------|--------|-----|-----|------|
| | | min | typ | max | |

Load Switching Capabilities and Characteristics

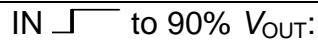
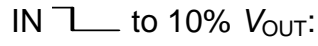
| | | | | | | |
|--|------------------|----------|----------------|----------------|------------------|----|
| On-state resistance (V_{bb} to OUT); $I_L = 5\text{ A}$ each channel, $T_j = 25^\circ\text{C}$: $T_j = 150^\circ\text{C}$: two parallel channels, $T_j = 25^\circ\text{C}$: | R_{ON} | -- | 27 54 14 | 30 60 15 | m Ω | |
| Output voltage drop limitation at small load currents, see page 14 $I_L = 0.5\text{ A}$ $T_j = -40\dots+150^\circ\text{C}$: | $V_{ON(NL)}$ | -- | 50 | -- | | mV |
| Nominal load current, ISO Norm one channel active: two parallel channels active: ISO 10483-1, 6.7: $V_{on} = 0.5\text{ V}$ $T_C = 85^\circ\text{C}$ | $I_{L(NOM)}$ | 11 22 | 12 24 | -- | | A |
| Output current while GND disconnected or pulled up ⁵⁾ ; $V_{bb} = 30\text{ V}$, $V_{IN} = 0$, see diagram page 10 | $I_{L(GNDhigh)}$ | -- | -- | 8 | mA | |
| Turn-on time ⁶⁾  to 90% V_{OUT} : | t_{on} | 25 | 70 | 150 | μs | |
| Turn-off time  to 10% V_{OUT} : $R_L = 12\ \Omega$ | t_{off} | 25 | 80 | 200 | | |
| Slew rate on ⁶⁾ 10 to 30% V_{OUT} , $R_L = 12\ \Omega$: | dV/dt_{on} | 0.1 | -- | 1 | V/ μs | |
| Slew rate off ⁶⁾ 70 to 40% V_{OUT} , $R_L = 12\ \Omega$: | $-dV/dt_{off}$ | 0.1 | -- | 1 | V/ μs | |

5) not subject to production test, specified by design

6) See timing diagram on page 11.

| Parameter and Conditions, each of the two channels at $T_j = -40\dots+150^\circ\text{C}$, $V_{bb} = 12\text{ V}$ unless otherwise specified | Symbol | Values | | | Unit |
|---|--------|--------|-----|-----|------|
| | | min | typ | max | |

Operating Parameters

| | | | | | |
|---|--|------------------------|----------|----------------------|---------------------|
| Operating voltage ⁷⁾ | $V_{bb(\text{on})}$ | 5.0 | -- | 34 | V |
| Undervoltage shutdown | $V_{bb(\text{under})}$ | 3.2 | -- | 5.0 | V |
| Undervoltage restart | $T_j = -40\dots+25^\circ\text{C}$: $T_j = +150^\circ\text{C}$: | $V_{bb(\text{u rst})}$ | -- | 4.5 5.5 6.0 | V |
| Undervoltage restart of charge pump see diagram page 13 | $T_j = -40\dots+25^\circ\text{C}$: $T_j = 150^\circ\text{C}$: | $V_{bb(\text{ucp})}$ | -- | 4.7 -- 7.0 | V |
| Undervoltage hysteresis $\Delta V_{bb(\text{under})} = V_{bb(\text{u rst})} - V_{bb(\text{under})}$ | $\Delta V_{bb(\text{under})}$ | -- | 0.5 | -- | V |
| Overshoot shutdown | $V_{bb(\text{over})}$ | 34 | -- | 43 | V |
| Overshoot restart | $V_{bb(\text{o rst})}$ | 33 | -- | -- | V |
| Overshoot hysteresis | $\Delta V_{bb(\text{over})}$ | -- | 1 | -- | V |
| Overshoot protection ⁸⁾ $I_{bb} = 40\text{ mA}$ | $T_j = -40^\circ\text{C}$: $T_j = +25\dots+150^\circ\text{C}$: | $V_{bb(\text{AZ})}$ | 41 43 | -- 47 52 | V |
| Standby current ⁹⁾ $V_{IN} = 0$ | $T_j = -40^\circ\text{C}\dots+25^\circ\text{C}$: $T_j = 150^\circ\text{C}$: | $I_{bb(\text{off})}$ | -- | 8 24 30 50 | μA |
| Leakage output current (included in $I_{bb(\text{off})}$); $V_{IN} = 0$ | | $I_{L(\text{off})}$ | -- | -- | 20 μA |
| Operating current ¹⁰⁾ , $V_{IN} = 5\text{V}$, $I_{GND} = I_{GND1} + I_{GND2}$, one channel on: two channels on: | | I_{GND} | -- | 1.2 2.4 3 6 | mA |

Protection Functions¹¹⁾

| | | | | | | |
|--|---|-----------------------------|----------------|----------------|----------------|----|
| Current limit, (see timing diagrams, page 12) | $T_j = -40^\circ\text{C}$: $T_j = 25^\circ\text{C}$: $T_j = +150^\circ\text{C}$: | $I_{L(\text{lim})}$ | 48 40 31 | 56 50 37 | 65 58 45 | A |
| Repetitive short circuit current limit, $T_j = T_{jt}$ each channel two parallel channels (see timing diagrams, page 12) | | $I_{L(\text{SCR})}$ | -- | 24 24 | -- -- | A |
| Initial short circuit shutdown time (see timing diagrams on page 12) | $T_{j,\text{start}} = 25^\circ\text{C}$: | $t_{\text{off}(\text{SC})}$ | -- | 4.0 | -- | ms |

7) At supply voltage increase up to $V_{bb} = 4.7\text{ V}$ typ without charge pump, $V_{OUT} \approx V_{bb} - 2\text{ V}$

8) Supply voltages higher than $V_{bb(\text{AZ})}$ require an external current limit for the GND and status pins (a $150\ \Omega$ resistor in the GND connection is recommended). See also $V_{ON(\text{CL})}$ in table of protection functions and circuit diagram page 9.

9) Measured with load; for the whole device; all channels off

10) Add I_{ST} , if $I_{ST} > 0$

11) Integrated protection functions are designed to prevent IC destruction under fault conditions described in the data sheet. Fault conditions are considered as "outside" normal operating range. Protection functions are not designed for continuous repetitive operation.

| Parameter and Conditions, each of the two channels at $T_j = -40\dots+150^\circ\text{C}$, $V_{bb} = 12\text{ V}$ unless otherwise specified | Symbol | Values | | | Unit |
|---|-----------------|----------|----------|----------|------------------|
| | | min | typ | max | |
| Output clamp (inductive load switch off) ¹²⁾ at $V_{ON(CL)} = V_{bb} - V_{OUT}$, $I_L = 40\text{ mA}$ $T_j = -40^\circ\text{C}$: $T_j = 25^\circ\text{C}\dots150^\circ\text{C}$: | $V_{ON(CL)}$ | 41 43 | -- 47 | -- 52 | V |
| Thermal overload trip temperature | T_{jt} | 150 | -- | -- | $^\circ\text{C}$ |
| Thermal hysteresis | ΔT_{jt} | -- | 10 | -- | K |

Reverse Battery

| | | | | | |
|---|-----------|----|-----|----|----|
| Reverse battery voltage ¹³⁾ | $-V_{bb}$ | -- | -- | 32 | V |
| Drain-source diode voltage ($V_{out} > V_{bb}$) $I_L = -4.0\text{ A}$, $T_j = +150^\circ\text{C}$ | $-V_{ON}$ | -- | 600 | -- | mV |

Diagnostic Characteristics

| | | | | | |
|---|---|------------------------------|------------------------------|------------------------------|---------------|
| Current sense ratio ¹⁴⁾ , static on-condition, $V_{IS} = 0\dots5\text{ V}$, $V_{bb(on)} = 6.5^{15)}\dots27\text{V}$, $k_{ILIS} = I_L / I_{IS}$ $T_j = -40^\circ\text{C}$, $I_L = 5\text{ A}$: $T_j = -40^\circ\text{C}$, $I_L = 0.5\text{ A}$: $T_j = 25\dots+150^\circ\text{C}$, $I_L = 5\text{ A}$: $T_j = 25\dots+150^\circ\text{C}$, $I_L = 0.5\text{ A}$: | k_{ILIS} | 4350 3100 4350 3800 | 4800 4800 4800 4800 | 5800 7800 5350 6300 | |
| Current sense output voltage limitation $T_j = -40\dots+150^\circ\text{C}$ $I_{IS} = 0$, $I_L = 5\text{ A}$: | $V_{IS(lim)}$ | 5.4 | 6.1 | 6.9 | V |
| Current sense leakage/offset current $T_j = -40\dots+150^\circ\text{C}$ $V_{IN}=0$, $V_{IS} = 0$, $I_L = 0$: $V_{IN}=5\text{ V}$, $V_{IS} = 0$, $I_L = 0$: $V_{IN}=5\text{ V}$, $V_{IS} = 0$, $V_{OUT} = 0$ (short circuit) | $I_{IS(LL)}$ $I_{IS(LH)}$ $I_{IS(SH)}$ ¹⁶⁾ | 0 0 0 | -- -- -- | 1 15 10 | μA |
| Current sense settling time to $I_{IS\text{ static}} \pm 10\%$ after positive input slope ¹⁶⁾ , $I_L = 0 \xrightarrow{\quad} 5\text{ A}$ | $t_{son(IS)}$ | -- | -- | 300 | μs |

¹²⁾ If channels are connected in parallel, output clamp is usually accomplished by the channel with the lowest $V_{ON(CL)}$

¹³⁾ Requires a $150\ \Omega$ resistor in GND connection. The reverse load current through the intrinsic drain-source diode has to be limited by the connected load. Power dissipation is higher compared to normal operating conditions due to the voltage drop across the drain-source diode. The temperature protection is not active during reverse current operation! Input and Status currents have to be limited (see max. ratings page 3 and circuit page 9).

¹⁴⁾ This range for the current sense ratio refers to all devices. The accuracy of the k_{ILIS} can be raised at least by a factor of two by matching the value of k_{ILIS} for every single device.



In the case of current limitation the sense current I_{IS} is zero and the diagnostic feedback potential V_{ST} is High. See figure 2c, page 12.

¹⁵⁾ Valid if $V_{bb(u\text{ rst})}$ was exceeded before.

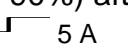
¹⁶⁾ not subject to production test, specified by design

| Parameter and Conditions, each of the two channels at $T_j = -40\dots+150^\circ\text{C}$, $V_{bb} = 12\text{ V}$ unless otherwise specified | Symbol | Values | | | Unit |
|--|------------------------|--------|-----|-----|------------------|
| | | min | typ | max | |
| Current sense settling time to 10% of I_S static after negative input slope ¹⁷⁾ , $I_L = 5 \text{ A}$  | $t_{\text{soff}}(I_S)$ | -- | 30 | 100 | μs |
| Current sense rise time (60% to 90%) after change of load current ¹⁷⁾ , $I_L = 2.5 \text{ A}$  | $t_{\text{slc}}(I_S)$ | -- | 10 | -- | μs |
| Open load detection voltage ¹⁸⁾ (off-condition) | $V_{\text{OUT(OL)}}$ | 2 | 3 | 4 | V |
| Internal output pull down (pin 16,17,18,19 to 2 resp. 12,13,14,15 to 6), $V_{\text{OUT}}=5\text{ V}$ | R_O | 5 | 15 | 40 | $\text{k}\Omega$ |

Input and Status Feedback¹⁹⁾

| | | | | | |
|--|---------------------------|-----|-----|-----|------------------|
| Input resistance (see circuit page 9) | R_I | 3.0 | 4.5 | 7.0 | $\text{k}\Omega$ |
| Input turn-on threshold voltage  | $V_{\text{IN(T+)}}$ | -- | -- | 3.5 | V |
| Input turn-off threshold voltage  | $V_{\text{IN(T-)}}$ | 1.5 | -- | -- | V |
| Input threshold hysteresis | $\Delta V_{\text{IN(T)}}$ | -- | 0.5 | -- | V |
| Off state input current $V_{\text{IN}} = 0.4\text{ V}$: | $I_{\text{IN(off)}}$ | 1 | -- | 50 | μA |
| On state input current $V_{\text{IN}} = 5\text{ V}$: | $I_{\text{IN(on)}}$ | 20 | 50 | 90 | μA |
| Delay time for status with open load after Input neg. slope (see diagram page 14) | $t_{\text{d(ST OL3)}}$ | -- | 400 | -- | μs |
| Status delay after positive input slope ¹⁷⁾ | $t_{\text{don(ST)}}$ | -- | 13 | -- | μs |
| Status delay after negative input slope ¹⁷⁾ | $t_{\text{doff(ST)}}$ | -- | 1 | -- | μs |
| Status output (open drain) | | | | | |
| Zener limit voltage $T_j = -40\dots+150^\circ\text{C}$, $I_{\text{ST}} = +1.6\text{ mA}$: | $V_{\text{ST(high)}}$ | 5.4 | 6.1 | 6.9 | V |
| ST low voltage $T_j = -40\dots+25^\circ\text{C}$, $I_{\text{ST}} = +1.6\text{ mA}$: | $V_{\text{ST(low)}}$ | -- | -- | 0.4 | |
| $T_j = +150^\circ\text{C}$, $I_{\text{ST}} = +1.6\text{ mA}$: | | -- | -- | 0.7 | |
| Status leakage current, $V_{\text{ST}} = 5\text{ V}$, $T_j = 25 \dots +150^\circ\text{C}$: | $I_{\text{ST(high)}}$ | -- | -- | 2 | μA |

¹⁷⁾ not subject to production test, specified by design

¹⁸⁾ External pull up resistor required for open load detection in off state.

¹⁹⁾ If ground resistors R_{GND} are used, add the voltage drop across these resistors.

Truth Table

| | Input 1 | Output 1 | Status 1 | Current Sense 1 |
|----------------------------------|---------|------------------|-----------------------|-------------------------|
| | Input 2 | Output 2 | Status 2 | Current Sense 2 |
| | level | level | level | I_{IS} |
| Normal operation | L | L | H | 0 |
| | H | H | L | nominal |
| Current-limitation | L | L | H | 0 |
| | H | H | H | 0 |
| Short circuit to GND | L | L | H | 0 |
| | H | L ²⁰⁾ | H | 0 |
| Over-temperature | L | L | H | 0 |
| | H | L | H | 0 |
| Short circuit to V _{bb} | L | H | L ²¹⁾ | 0 |
| | H | H | L | <nominal ²²⁾ |
| Open load | L | L ²³⁾ | H (L ²⁴⁾) | 0 |
| | H | H | L | 0 |
| Undervoltage | L | L | H | 0 |
| | H | L | L | 0 |
| Overvoltage | L | L | H | 0 |
| | H | L | L | 0 |
| Negative output voltage clamp | L | L | H | 0 |

L = "Low" Level X = don't care Z = high impedance, potential depends on external circuit
H = "High" Level Status signal after the time delay shown in the diagrams (see fig 5. page 13)
Parallel switching of channel 1 and 2 is possible by connecting the inputs and outputs in parallel. The status outputs ST1 and ST2 have to be configured as a 'Wired OR' function with a single pull-up resistor. The current sense outputs IS1 and IS2 have to be connected with a single pull-down resistor.

Terms

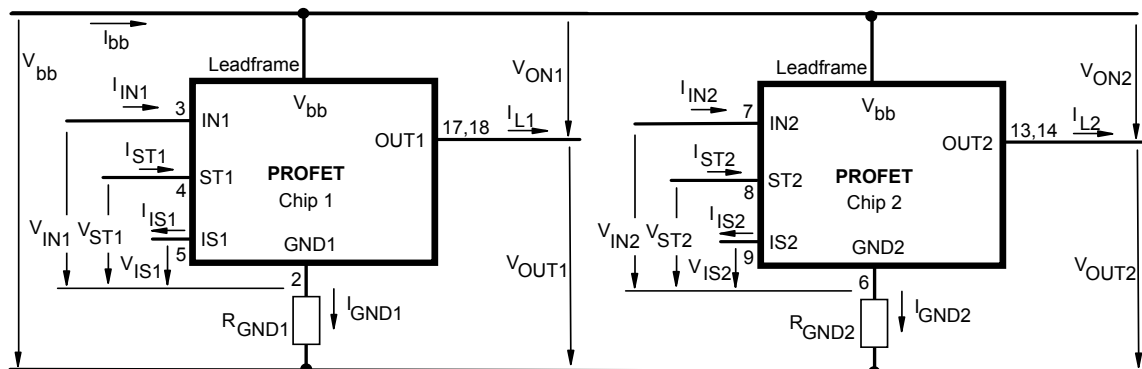

Leadframe (V_{bb}) is connected to pin 1,10,11,20
External R_{GND} optional; two resistors R_{GND1} , $R_{GND2} = 150 \Omega$ or a single resistor $R_{GND} = 75 \Omega$ for reverse battery protection up to the max. operating voltage.

- 20) The voltage drop over the power transistor is $V_{bb} - V_{OUT} > 3V$ typ. Under this condition the sense current I_{IS} is zero
- 21) An external short of output to V_{bb} , in the off state, causes an internal current from output to ground. If R_{GND} is used, an offset voltage at the GND and ST pins will occur and the $V_{ST\ low}$ signal may be errorious.
- 22) Low ohmic short to V_{bb} may reduce the output current I_L and therefore also the sense current I_{IS} .
- 23) Power Transistor off, high impedance
- 24) with external resistor between V_{BB} and OUT

Input circuit (ESD protection), IN1 or IN2

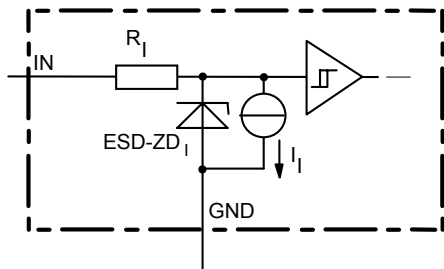

The use of ESD zener diodes as voltage clamp at DC conditions is not recommended.

Status output, ST1 or ST2

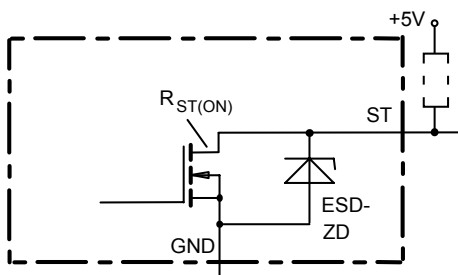

ESD-Zener diode: 6.1 V typ., max 5.0 mA; $R_{ST(ON)} < 375 \Omega$ at 1.6 mA. The use of ESD zener diodes as voltage clamp at DC conditions is not recommended.

Current sense output, IS1 or IS2

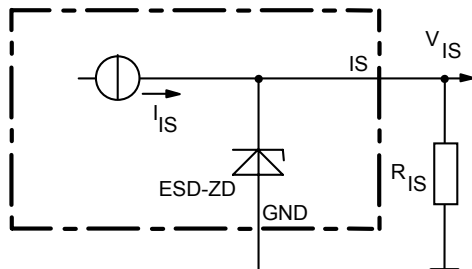

ESD-Zener diode: 6.1 V typ., max 14 mA; $R_{IS} = 1 \text{ k}\Omega$ nominal

Inductive and overvoltage output clamp, OUT1 or OUT2

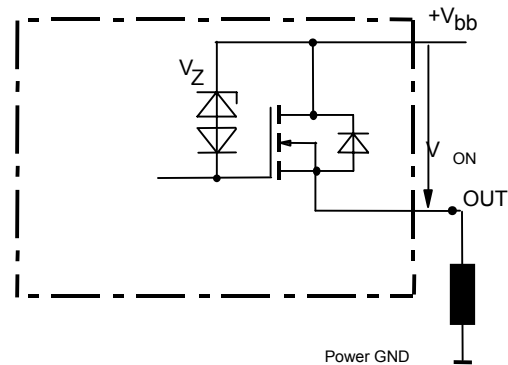

V_{ON} clamped to $V_{ON(CL)} = 47 \text{ V typ.}$

Overvoltage and reverse batt. Protection

For each channel

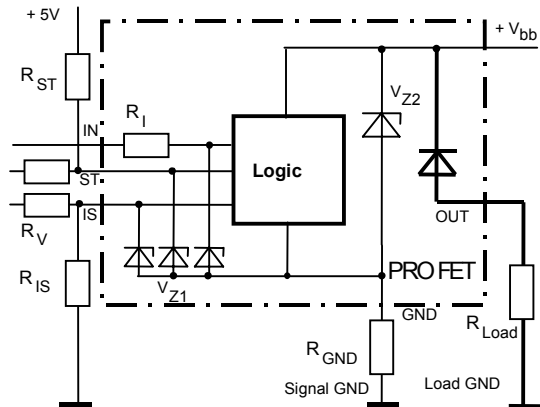

$V_{Z1} = 6.1 \text{ V typ.}$, $V_{Z2} = 47 \text{ V typ.}$, $R_{GND} = 150 \Omega$, $R_{ST} = 15 \text{ k}\Omega$, $R_I = 4.5 \text{ k}\Omega \text{ typ.}$, $R_{IS} = 1 \text{ k}\Omega$, $R_V = 15 \text{ k}\Omega$. In case of reverse battery the current has to be limited by the load. Temperature protection is not active

Open-load detection OUT1 or OUT2

OFF-state diagnostic condition:

$V_{OUT} > 3 \text{ V typ.}$; IN low

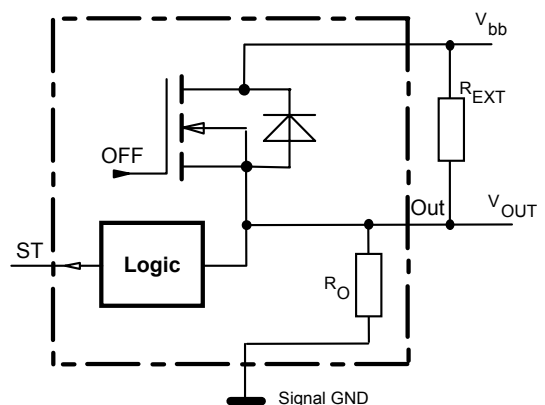

GND disconnect, each channel

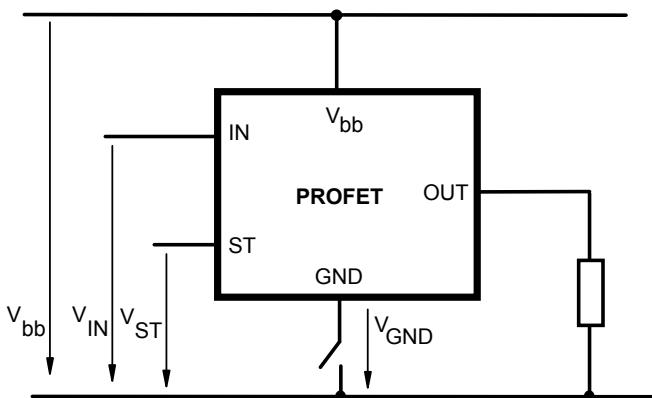

Any kind of load. In case of IN=high is $V_{OUT} \approx V_{IN} - V_{IN(T+)}$. Due to $V_{GND} > 0$, no $V_{ST} = \text{low}$ signal available.

GND disconnect with GND pull up each channel

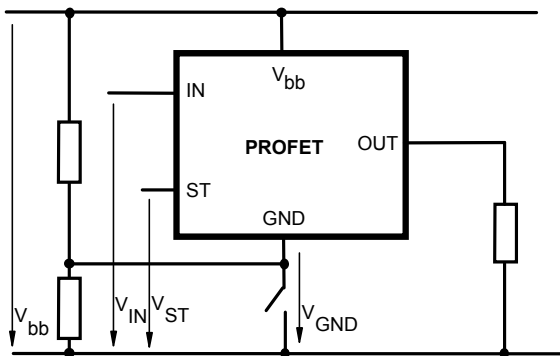

Any kind of load. If $V_{GND} > V_{IN} - V_{IN(T+)}$ device stays off. Due to $V_{GND} > 0$, no $V_{ST} = \text{low}$ signal available.

Vbb disconnect with energized inductive load, each channel

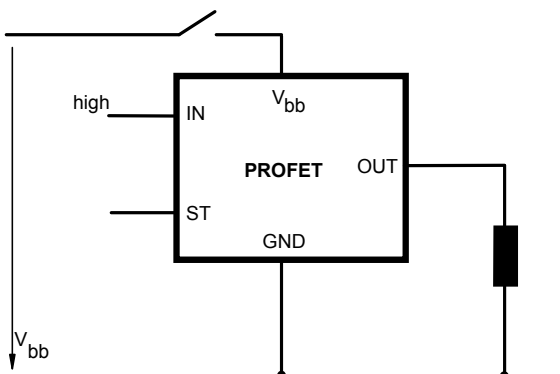

For inductive load currents up to the limits defined by Z_L (max. ratings and diagram on page 10) each switch is protected against loss of V_{bb} .

Consider at your PCB layout that in the case of V_{bb} disconnection with energized inductive load all the load current flows through the GND connection.

Inductive load switch-off energy dissipation, each channel

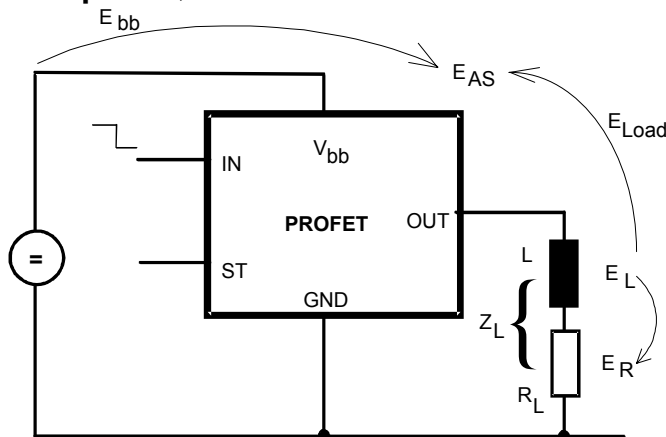

Energy stored in load inductance:

$$E_L = 1/2 \cdot L \cdot I_L^2$$

While demagnetizing load inductance, the energy dissipated in PROFET is

$$E_{AS} = E_{bb} + E_L - E_R = \int V_{ON(CL)} \cdot i_L(t) dt,$$

with an approximate solution for $R_L > 0 \Omega$:

$$E_{AS} = \frac{I_L \cdot L}{2 \cdot R_L} (V_{bb} + |V_{OUT(CL)}|) \ln \left(1 + \frac{I_L \cdot R_L}{|V_{OUT(CL)}|} \right)$$

Maximum allowable load inductance for a single switch off (one channel)⁴⁾

$$L = f(I_L); T_{j,start} = 150^\circ\text{C}, V_{bb} = 12\text{V}, R_L = 0 \Omega$$

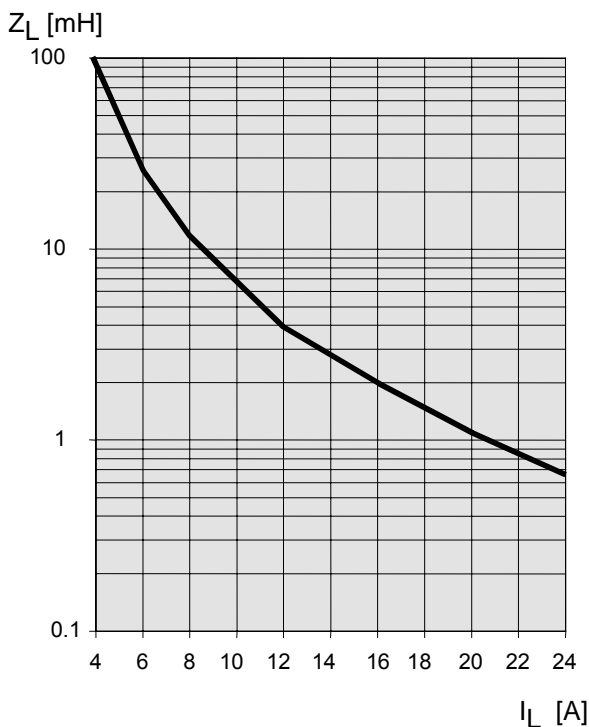

Timing diagrams

Both channels are symmetric and consequently the diagrams are valid for channel 1 and channel 2

Figure 1a: Switching a resistive load, change of load current in on-condition:

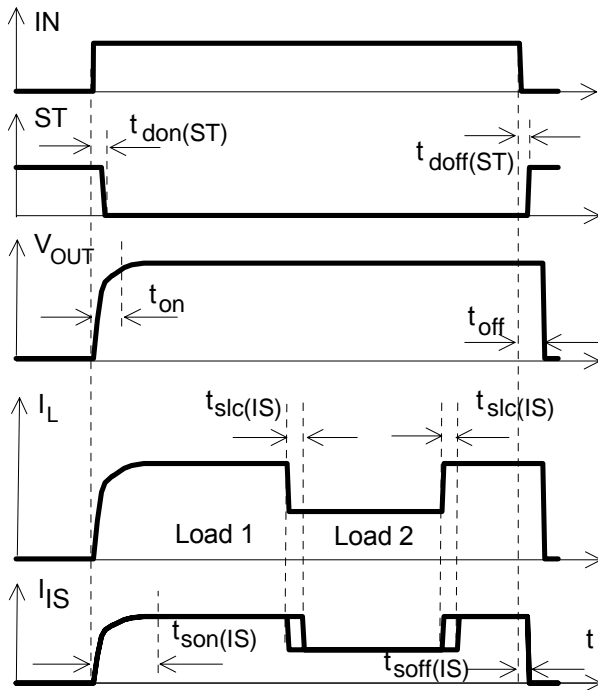

The sense signal is not valid during settling time after turn or change of load current.

Figure 1b: V_{bb} turn on:

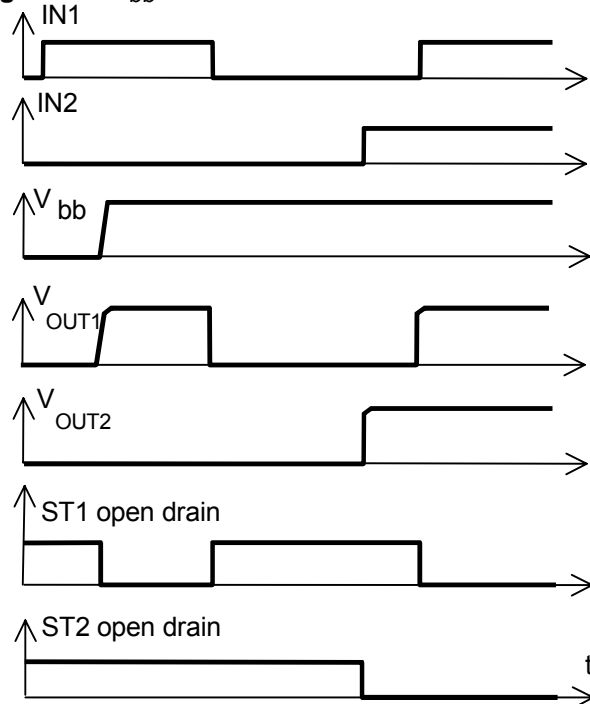

proper turn on under all conditions

Figure 2a: Switching a resistive load, turn-on/off time and slew rate definition:

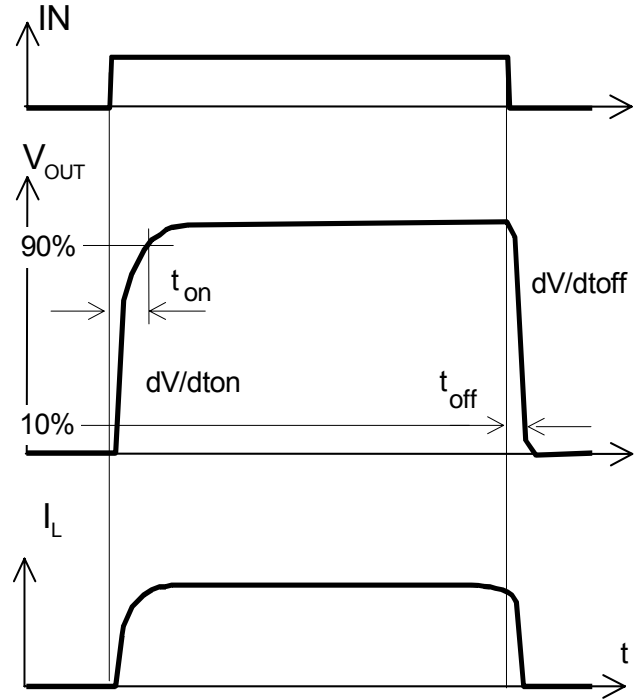
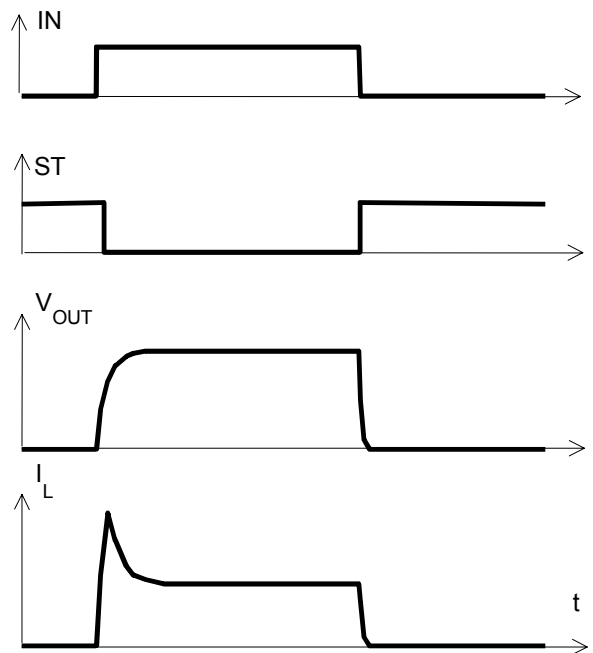

Figure 2b: Switching a lamp:



The initial peak current should be limited by the lamp and not by the current limit of the device.

Figure 2c: Switching a lamp with current limit:

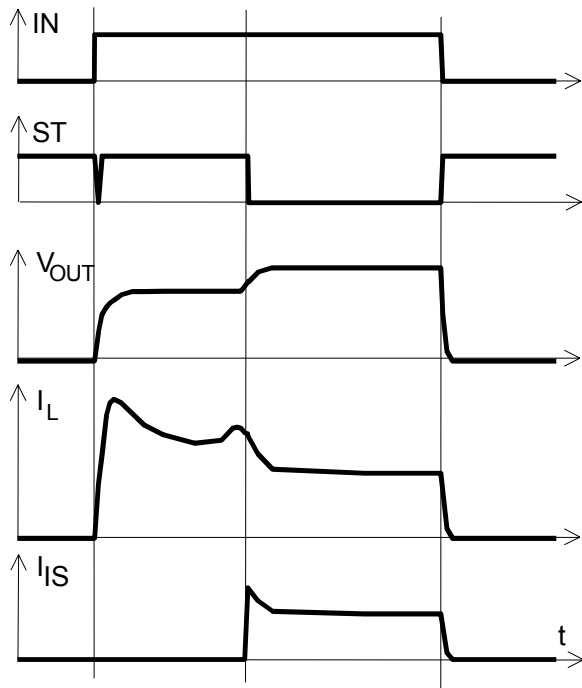
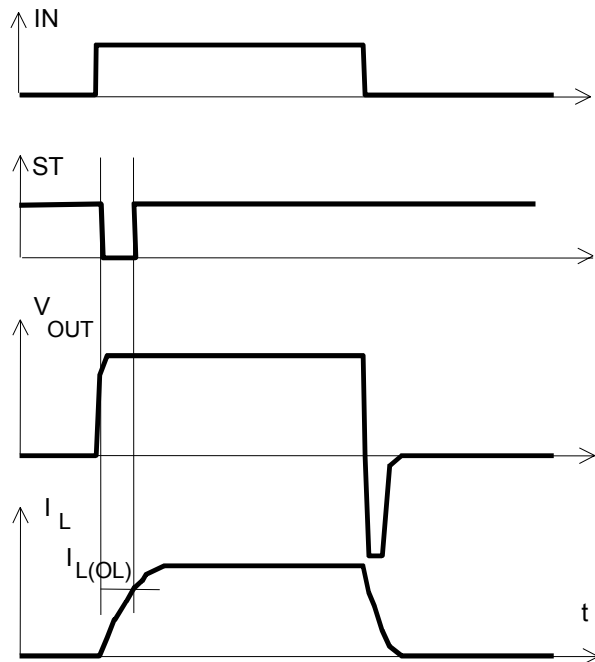
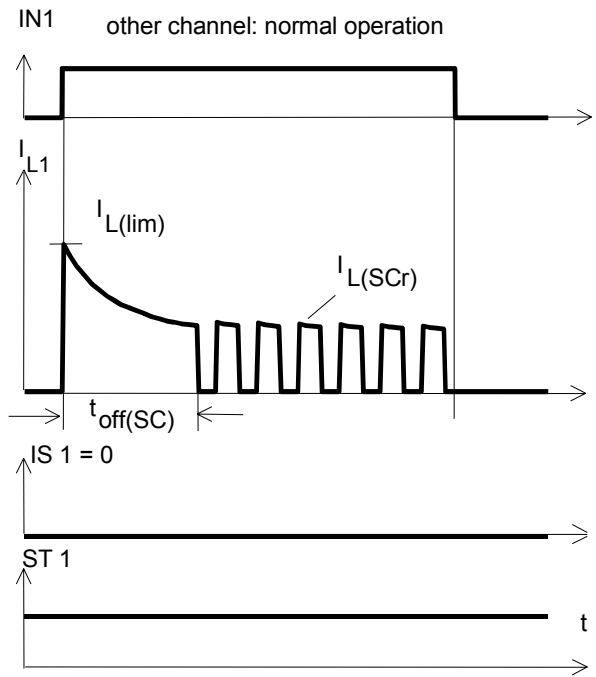

Figure 2d: Switching an inductive load



*) if the time constant of load is too large, open-load-status may occur

Figure 3a: Turn on into short circuit: shut down by overtemperature, restart by cooling



Heating up of the chip may require several milliseconds, depending on external conditions

Figure 3b: Turn on into short circuit: shut down by overtemperature, restart by cooling (two parallel switched channels 1 and 2)

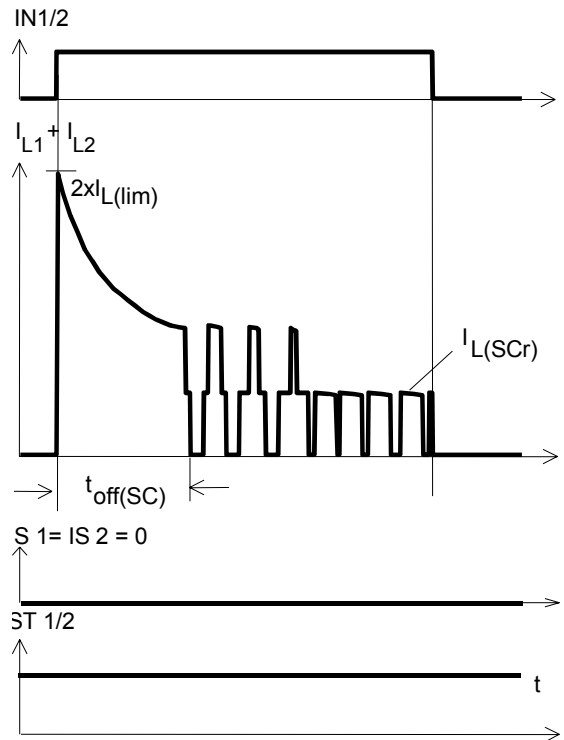

ST1 and ST2 have to be configured as a 'Wired OR' function ST1/2 with a single pull-up resistor.

Figure 4a: Overtemperature:
Reset if $T_j < T_{jt}$

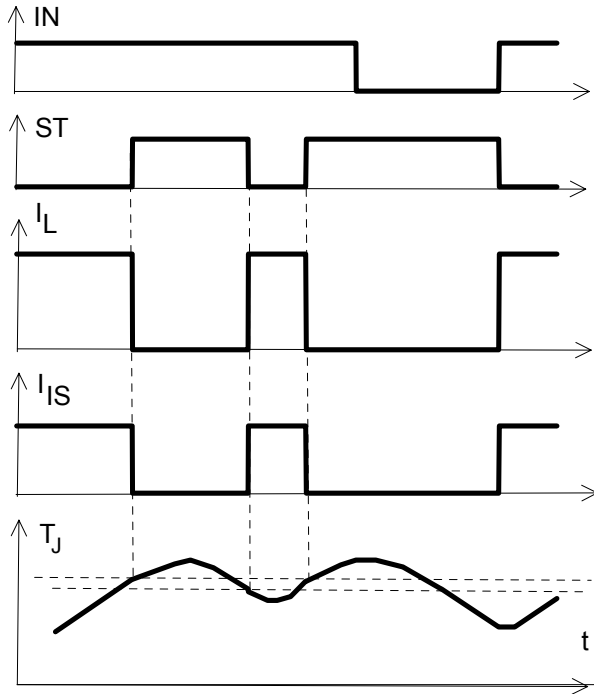

Figure 5a: Open load: detection (with R_{EXT}),
turn on/off to open load

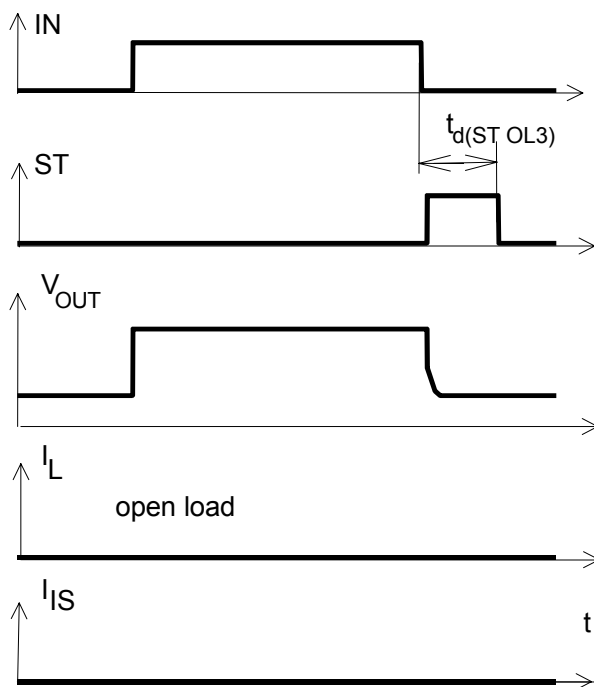

Figure 6a: Undervoltage:

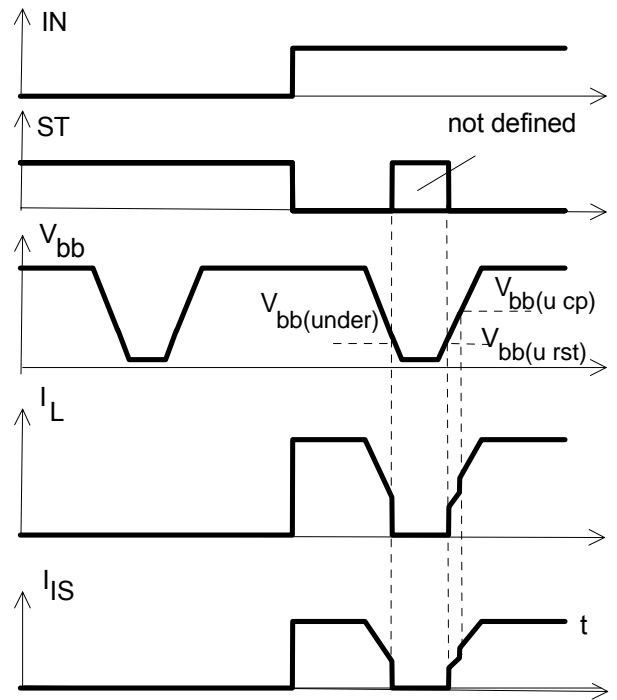
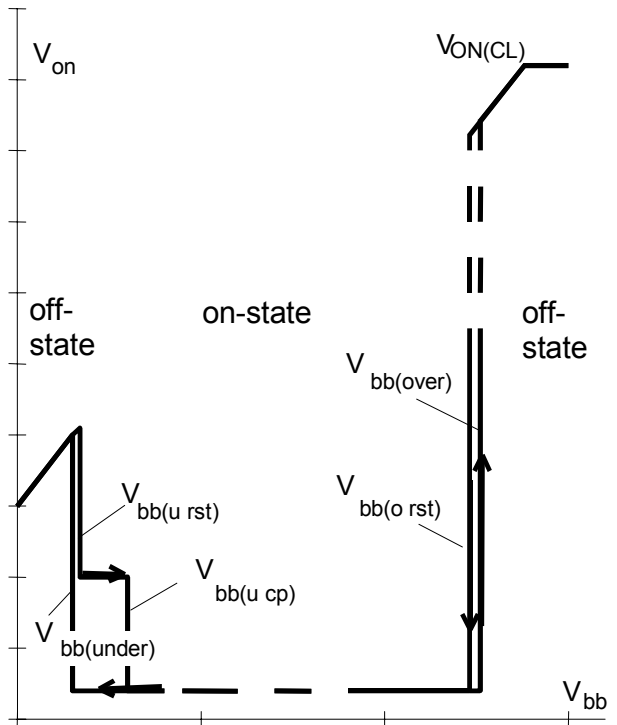

Figure 6b: Undervoltage restart of charge pump



charge pump starts at $V_{bb(ucp)} = 4.7 \text{ V typ.}$

Figure 7a: Overvoltage:

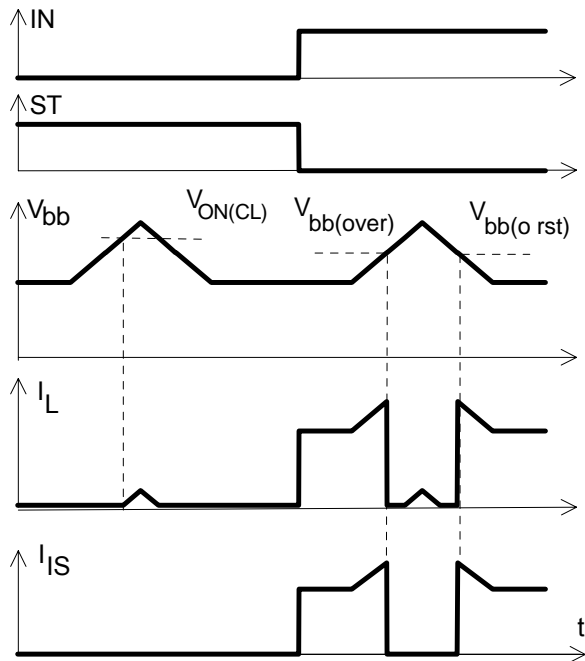

Figure 8b: Current sense ratio:

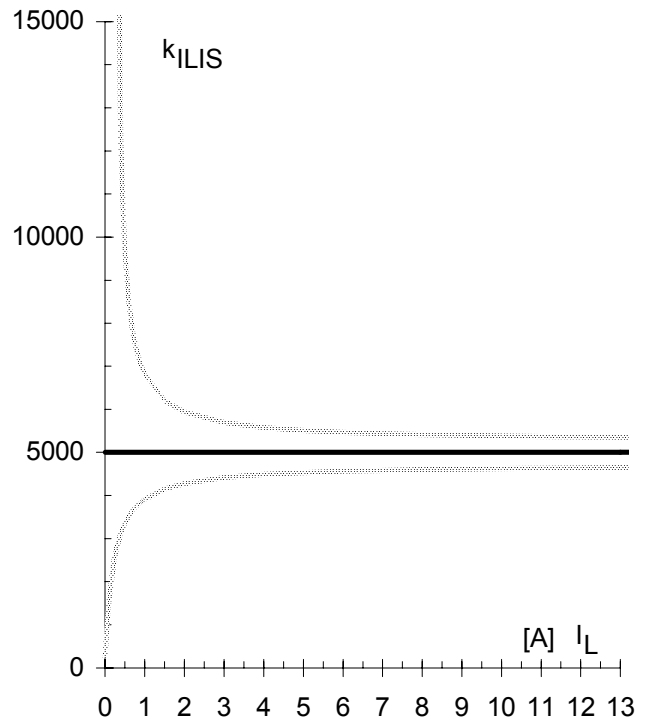

Figure 8a: Current sense versus load current²⁵:

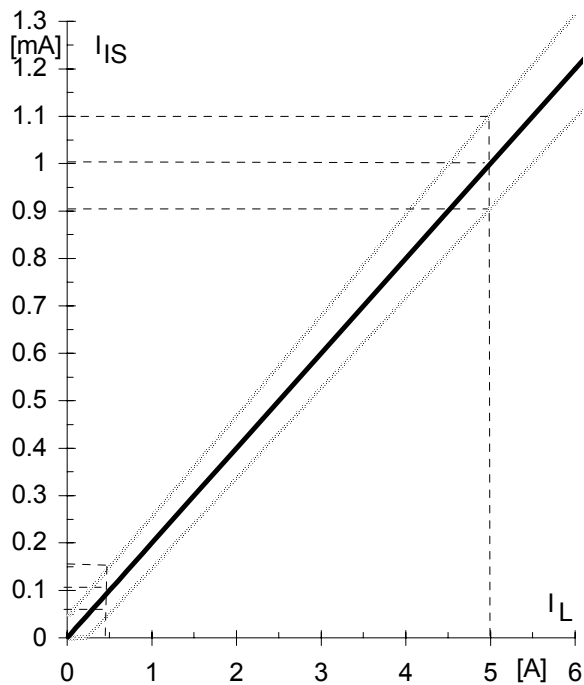
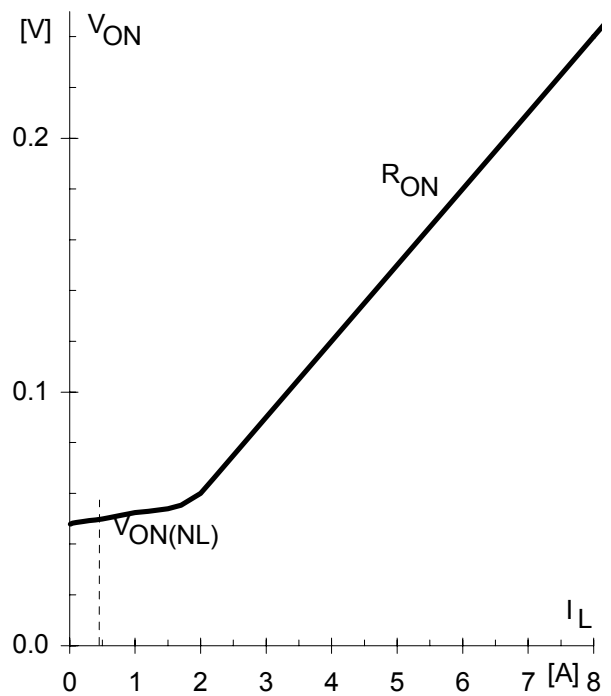

Figure 9a: Output voltage drop versus load current:



²⁵ This range for the current sense ratio refers to all devices. The accuracy of the k_{ILIS} can be raised at least by a factor of two by matching the value of k_{ILIS} for every single device.

Package and Ordering Code

Standard: P-DSO-20-12 (Power SO 20)

| | |
|---------------|--------------|
| Sales Code | BTS 840 |
| Ordering Code | Q67060-S7013 |

All dimensions in millimetres

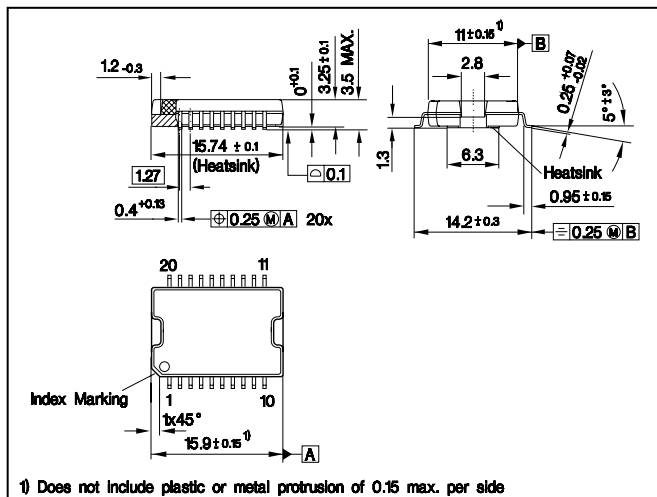

Published by
Infineon Technologies AG,
St.-Martin-Strasse 53,
D-81669 München
 © Infineon Technologies AG 2001
All Rights Reserved.

Attention please!

The information herein is given to describe certain components and shall not be considered as a guarantee of characteristics.

Terms of delivery and rights to technical change reserved.

We hereby disclaim any and all warranties, including but not limited to warranties of non-infringement, regarding circuits, descriptions and charts stated herein.

Infineon Technologies is an approved CECC manufacturer.

Information

For further information on technology, delivery terms and conditions and prices please contact your nearest Infineon Technologies Office in Germany or our Infineon Technologies Representatives worldwide (see address list).

Warnings

Due to technical requirements components may contain dangerous substances. For information on the types in question please contact your nearest Infineon Technologies Office.

Infineon Technologies Components may only be used in life-support devices or systems with the express written approval of Infineon Technologies, if a failure of such components can reasonably be expected to cause the failure of that life-support device or system, or to affect the safety or effectiveness of that device or system. Life support devices or systems are intended to be implanted in the human body, or to support and/or maintain and sustain and/or protect human life. If they fail, it is reasonable to assume that the health of the user or other persons may be endangered.