

TWO CHANNEL PROFET®

- Two independent high-side switches
- Overtemperature protection for each channel
- Overload protection for each channel
- Short circuit protection by overtemperature protection ²⁾
- Overvoltage protection
- Input protection
- Clamp of negative output voltage with inductive loads
- Open load detection in OFF-state
- Maximum current internally limited
- Protection against loss of ground
- Undervoltage shutdown with reset and hysteresis
- Overvoltage shutdown with reset and hysteresis
- Open drain status feedback
- Electrostatic discharge (ESD) protection

Description PROFET® an intelligent power switch with integrated protection against self-destruction

Application Power switch for all kinds of loads.

Case Plastic package, similar to TO 220
Pin 4 is shorted to the mounting flange

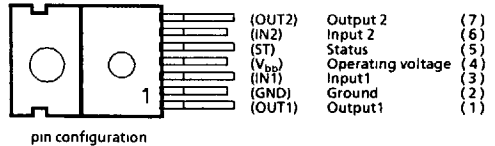

MAXIMUM RATINGS

TO220 / 7

DESCRIPTION	SYMBOL	RATINGS	UNIT	CONDITIONS
Breakdown voltage	$V_{bb(A2)}$ ¹⁾	> 40	V	$T_j = -40... +150^\circ\text{C}$, $I_{bb} = 1\text{mA}$
Short circuit current	I_{SC}	self-limited		
Max. power dissipation	P_D	50	W	$T_C = 25^\circ\text{C}$
Operating temperature range	T_j	-40 + 150	°C	
Storage temperature range	T_{stg}	-55 + 150	°C	
Status-pin current	I_{ST}	5	mA	
Thermal resistance				
Chip - case	R_{thJC}	2.5	K / W	for both channels
Chip - case	R_{thIC}	ca. 5	K / W	for each channel
Chip - ambient	R_{thJA}	75	K / W	

Type	Ordering code
BTS 612	C67078-55505-A2

¹⁾ Internal active c'amp

²⁾ Valid for 12 V applications only. For 24 V application available from middle of 1994 onwards

BLOCK DIAGRAM

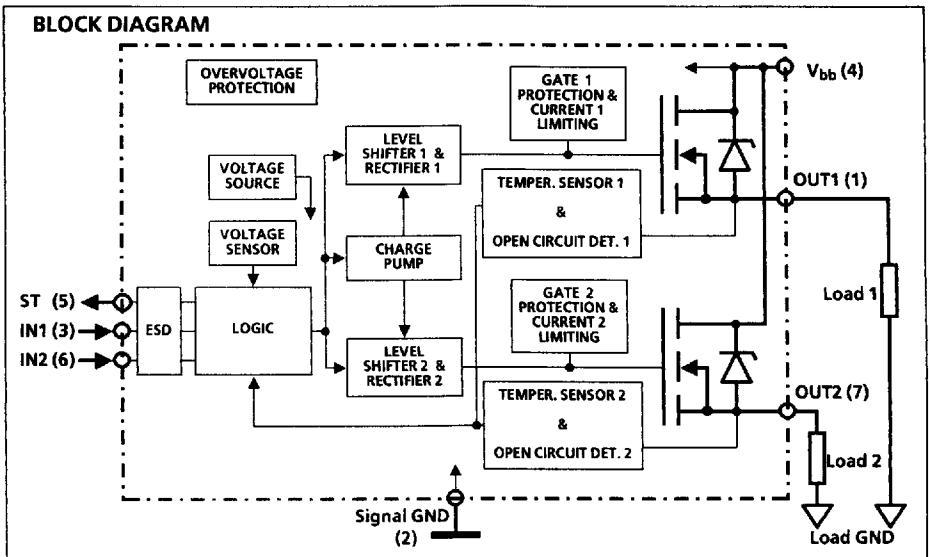

Description	Symbol	Characteristics			Unit	Conditions
		min.	typ.	max.		
Drain-source on-state resistance (Pin 4 to 7/1)	$R_{DS(on)}$	-	-	200	$\text{m}\Omega$	$V_{bb} = 12\text{ V}, I_L = 2\text{ A}$
Operating voltage (Pin 4 to 2)	V_{bb}	5.8	-	34	V	$T_j = -40 \dots +150^\circ\text{C}$
Nominal current, calculated value (Pin 7/1 to GND)	$I_L\text{-ISO}$	1.8	-	-	A	ISO-proposal: $V_{bb} - V_{out} \leq 0.5\text{ V},$ $T_C = 85^\circ\text{C}$
Load current, theoretical value (Pin 7/1 to GND)	$I_L\text{-MOS}$	-	-	14	A	MOS-standard: $T_C = 25^\circ\text{C},$ $T_j = 150^\circ\text{C}$
Load current limit (Pin 7/1 to GND)	I_{LLim}	-	11	-	A	onset of active regulation when: $V_{bb} - V_{out} > 1\text{ V}$
Standby current (Pin 4)	I_R	-	80	120	μA	$V_{bb} = 12\text{ V}$
Voltage threshold for open load detection in OFF - state	V_{OC}	2	3	4	V	
Input voltage (Pin 6/3 to 2)	$V_{in(off)}$ $V_{in(on)}$	-0.5 3.5	- -	1.5 20	V	$V_{bb} = 12\text{ V}$
Input current (Pin 6/3)	$I_{in(off)}$ $I_{in(on)}$	1 20	- 50	50 80	μA	$V_{in(off)} = 0.4\text{ V}$ $V_{in(on)} = 2.5\text{ V}$
Trip temperature	T_t	150	-	-	$^\circ\text{C}$	automatic shutdown
Slew rate	di/dt_{on} di/dt_{off}	0.01 0.01	- -	0.1 0.1	$\text{A}/\mu\text{s}$	$V_{bb} = 12\text{ V}$ Resistive Load $I_L = 2\text{ A}$
Status (Open drain)	$V_{St (high)}$ $V_{St (low)}$	5 -	- -	7 0.8	V	$I_{St} = 50\ \mu\text{A}$ $I_{St} = 1.6\text{ mA}, T_j = -40 \dots +150^\circ\text{C}$
negative inductive clamp voltage	V_{ind}	-	33	-	V	$V_{bb} = 12\text{ V}$ $V_{ind} = V_{bb(AZ)} - V_{bb}$ $V_{bb(AZ)} = 45\text{ V}_{typ}$
Reverse polarity (Pin 2 to 4) *	$-V_{bb}$	-	-	32	V	

*) Requires 150 Ω resistor in GND connection. Reverse load current (through intrinsic drain-source diode) is normally limited by the connected load. Input and Status currents have to be limited. It is recommend that 15k Ω resistors be inserted in series with IN and ST.

Truth table (priority given to activated ($V_{in} = \text{high}$) channel in the event of status conflict)

		IN1	IN2	OUT1	OUT2	ST
Normal operation		L	L	L	L	H
		H	H	H	H	H
		L	H	L	H	H
		H	L	H	L	H
Undervoltage / Overvoltage		X	X	L	L	H
Overtemperature	Channel 1	H	X	L	X	L
	Channel 2	X	H	X	L	L
	Ch.1 / Ch.2	L	L	L	L	H
Open Load	Channel 1	H	X	H	X	H
		L	L	H	L	L
		L	H	H	H	H
	Channel 2	X	H	X	H	H
		L	L	L	H	L
		H	L	H	H	H

L = "Low" level

X = "Don't care"

H = "High" level

Z = Potential defined by external impedance

Status timing : see applications

Operating range (typ. at $T_j = 25\text{ }^\circ\text{C}$)

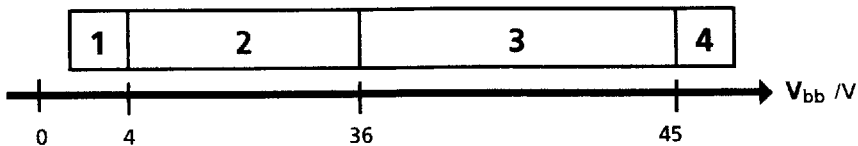

- 1: Undervoltage sensor causes the device to switch off
- 2: Normal operation
- 3: Overvoltage sensor causes the device to switch off
- 4: Increase of current between pin 4 and 2 from Zener diode to protect the circuit against overvoltage spikes

This power switch is fully protected against loss of ground (see below).
 By definition: no load current flows in the load despite loss of ground

1: Broken ground line at the BTS...

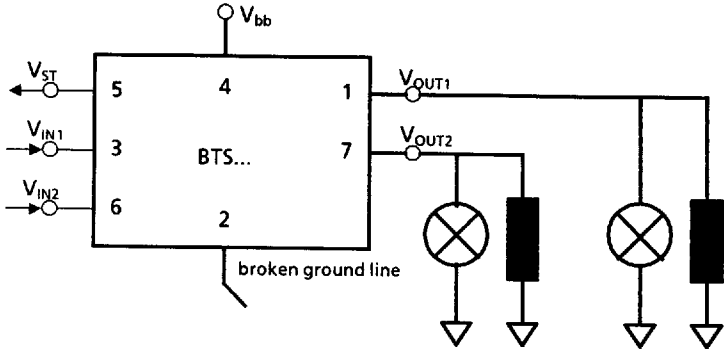

2: Broken ground line in the system, ground pulled high by Interface

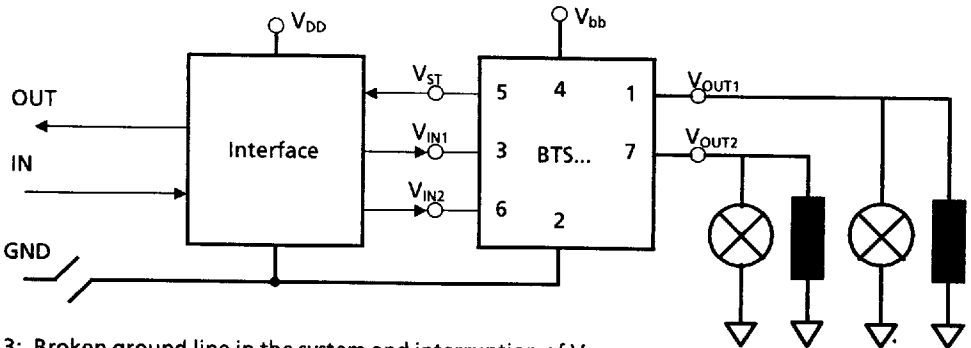

3: Broken ground line in the system and interruption of V_bb

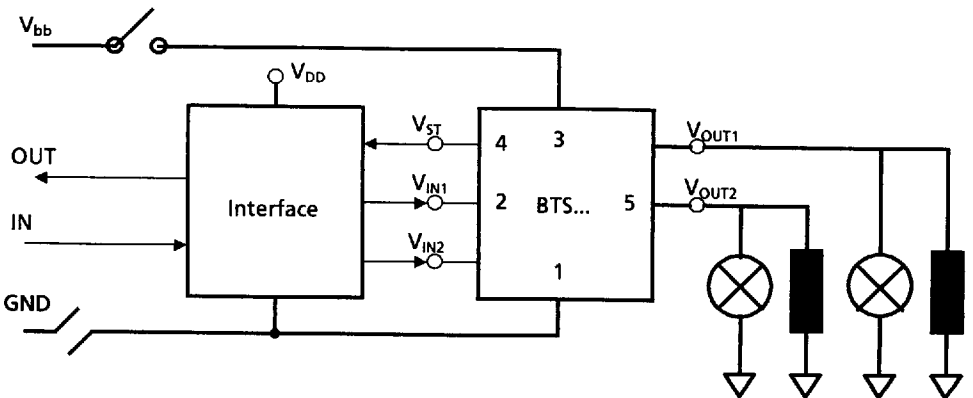

ESD Protected Logic-Inputs: IN1 / IN2 (3 / 6)

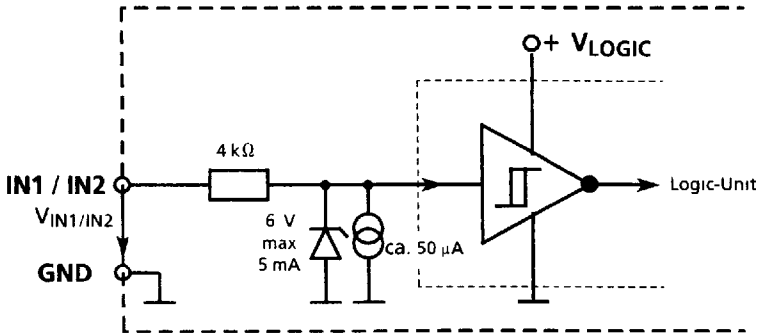

ESD Protected Status-Output: ST (5)

Open drain output with a typical output voltage of 6.0 V

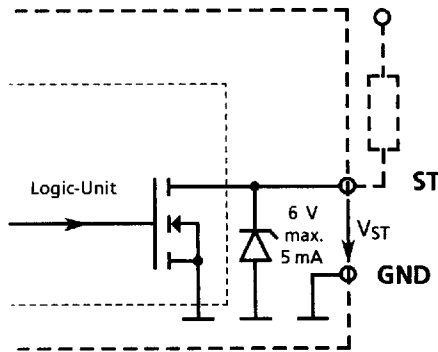

Voltage Sensor (typ. at $T_j = 25\text{ }^\circ\text{C}$) :

Undervoltage sensor

Overvoltage sensor

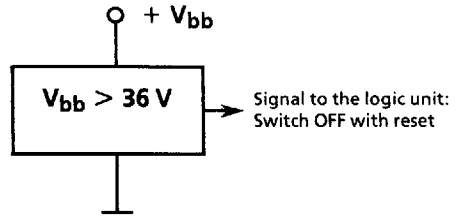
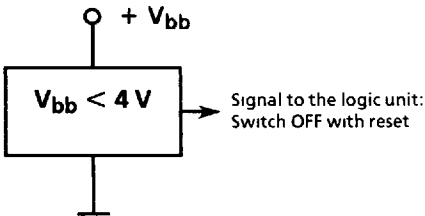

Open load detection in OFF - state

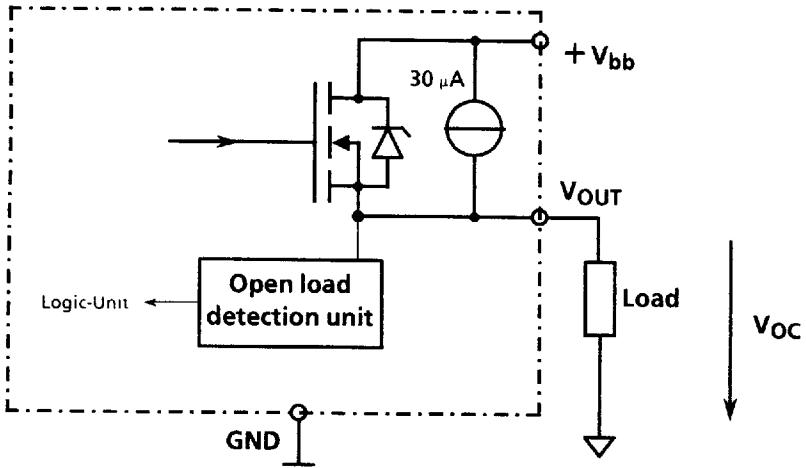

The "Open load detection" unit monitors the voltage between OUT and GND

1: Switching lamp loads or inductive loads

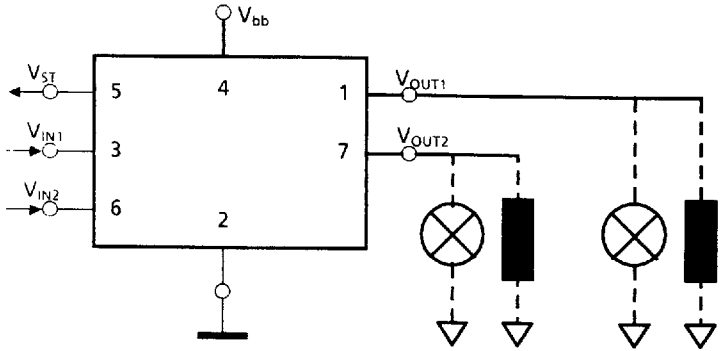
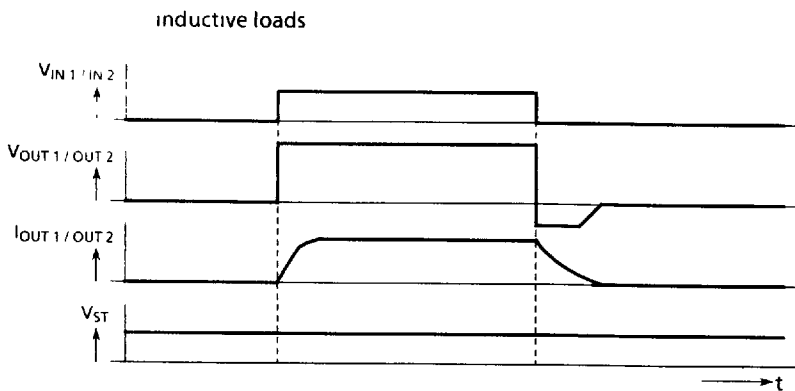
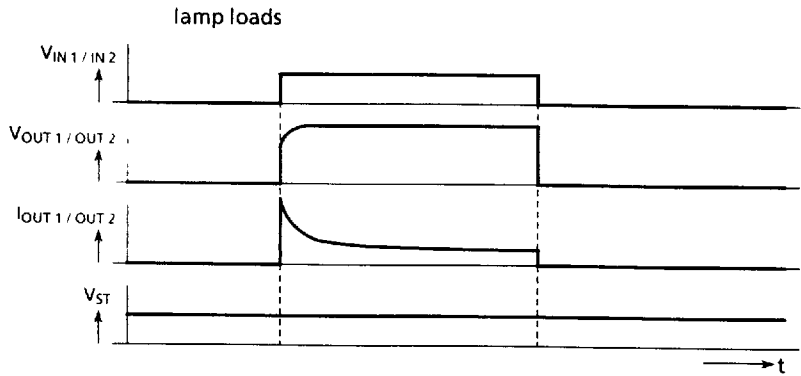

Diagram for each channel



2: Operation with overload / overtemperature

Diagram is representative of each channel.

The channel not shown is in the OFF - state (normal operation)

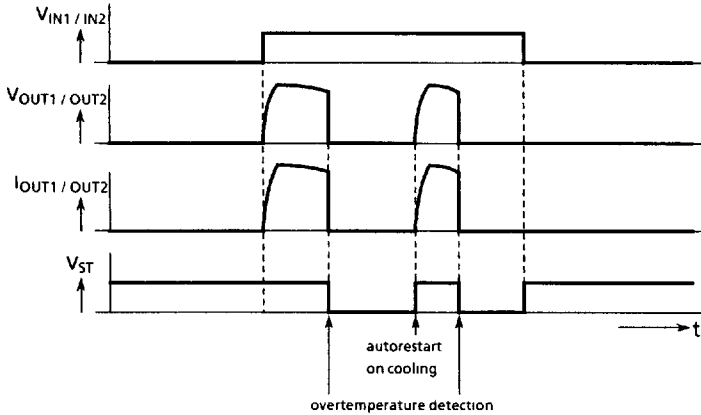
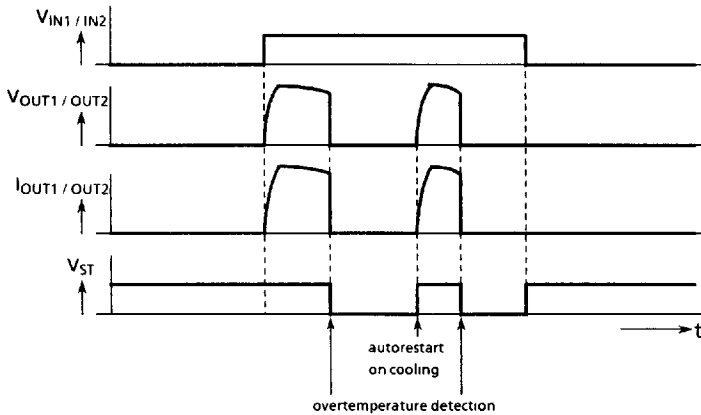

Diagram is representative of each channel.

The channel not shown is in the ON - state (normal operation)



3: Operation with open load

Diagram is representative of each channel.

The channel not shown is in the OFF - state (normal operation)

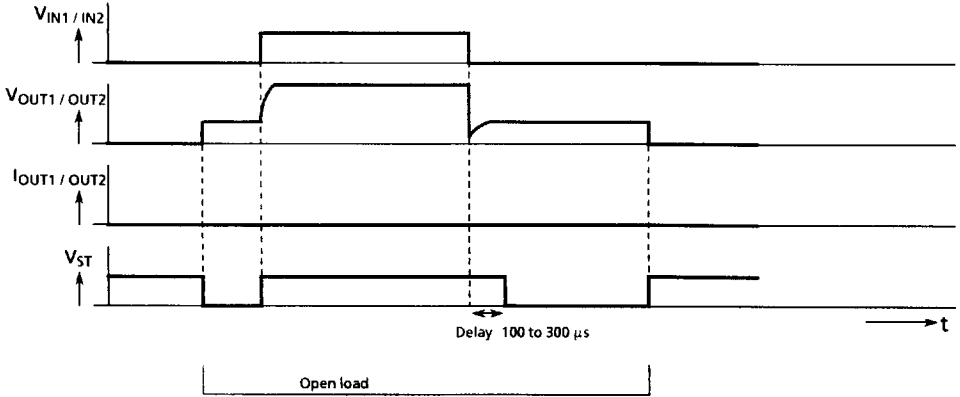

Diagram is representative of each channel.

The channel not shown is in the ON - state (normal operation)

