

# BTS50015-1TAD

## Smart High-Side Power Switch



### 1 Overview

#### Features

- One channel device
- Low Stand-by current
- 3.3 V to  $V_S$  level capable input pin
- Electrostatic discharge protection (ESD)
- Optimized Electromagnetic Compatibility (EMC)
- Logic ground independent from load ground
- Very low leakage current at OUT pin
- Compatible to cranking pulse requirement (test pulse 4 of ISO 7637 and cold start pulse in LV124)
- Embedded diagnostic functions
- Embedded protection functions
- Green Product (RoHS compliant)
- AEC Qualified

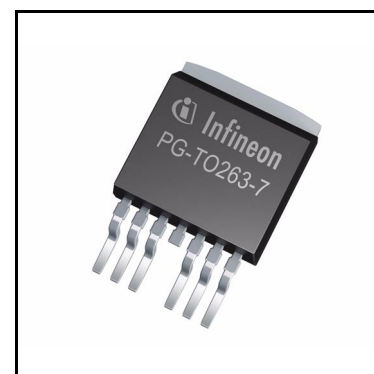

#### Applications

- Suitable for resistive, inductive and capacitive loads
- Replaces electromechanical relays, fuses and discrete circuits
- Most suitable for applications with high current loads, such as heating system, main switch for power distribution, start-stop power supply switch
- PWM applications with low frequencies

#### Description

The BTS50015-1TAD is a 1.5 m $\Omega$  single channel Smart High-Side Power Switch, embedded in a PG-TO-263-7-8 package, providing protective functions and diagnosis. It contains Infineon® ReverSave™ functionality. The power transistor is built by a N-channel power MOSFET with charge pump. It is specially designed to drive high current loads up to 80 A, for applications like switched battery couplings, power distribution switches, heaters, glow plugs, in the harsh automotive environment.

**Table 1 Product Summary**

Parameter	Symbol	Values
Operating voltage range	$V_{S(OP)}$	8 V ... 18 V
Extended supply voltage including dynamic undervoltage capability	$V_{S(DYN)}$	3.2 V ... 28 V

**Overview**

**Table 1 Product Summary (cont'd)**

Parameter	Symbol	Values
Maximum ON-state resistance ( $T_J = 150^\circ\text{C}$ )	$R_{DS(ON)}$	3 m $\Omega$
Minimum nominal load current ( $T_A = 85^\circ\text{C}$ )	$I_{L(NOM)}$	33 A
Typical current sense differential ratio	$dk_{ILIS}$	51500
Minimum short circuit current threshold	$I_{CL(0)}$	135 A
Maximum stand-by current for the whole device with load ( $T_A = T_J = 85^\circ\text{C}$ )	$I_{VS(OFF)}$	18 $\mu\text{A}$
Maximum reverse battery voltage ( $T_A = 25^\circ\text{C}$ for 2 min)	$-V_{S(REV)}$	16 V

**Embedded Diagnostic Functions**

- Proportional load current sense
- Short circuit / Overtemperature detection
- Latched status signal after short circuit or overtemperature detection

**Embedded Protection Functions**

- Infineon<sup>®</sup> ReverSave™: Reverse battery protection by self turn ON of power MOSFET
- Infineon<sup>®</sup> Inversave: Inverse operation robustness capability
- Secure load turn-OFF while device loss of GND connection
- Overtemperature protection with latch
- Short circuit protection with latch
- Overvoltage protection with external components
- Enhanced short circuit operation
- Infineon<sup>®</sup> SMART CLAMPING

Type	Package	Marking
BTS50015-1TAD	PG-TO-263-7-8	S50015D

## Table of Contents

<b>1</b>	<b>Overview</b> .....	<b>1</b>
	<b>Table of Contents</b> .....	<b>3</b>
	<b>List of Tables</b> .....	<b>5</b>
	<b>List of Figures</b> .....	<b>6</b>
<b>2</b>	<b>Block Diagram</b> .....	<b>7</b>
<b>3</b>	<b>Pin Configuration</b> .....	<b>8</b>
3.1	Pin Assignment .....	8
3.2	Pin Definitions and Functions .....	8
3.3	Voltage and Current Definition .....	9
<b>4</b>	<b>General Product Characteristics</b> .....	<b>10</b>
4.1	Absolute Maximum Ratings .....	10
4.2	Functional Range .....	14
4.3	Thermal Resistance .....	15
<b>5</b>	<b>Functional Description</b> .....	<b>16</b>
5.1	Power Stage .....	16
5.1.1	Output ON-State Resistance .....	16
5.1.2	Switching Resistive Loads .....	16
5.1.3	Switching Inductive Loads .....	16
5.1.3.1	Output Clamping .....	16
5.1.3.2	Maximum Load Inductance .....	17
5.1.4	Switching Active Loads .....	18
5.1.5	Inverse Current Capability .....	19
5.1.6	PWM Switching .....	20
5.1.7	Advanced switch-off behavior .....	20
5.2	Input Pins .....	21
5.2.1	Input Circuitry .....	21
5.2.2	Input Pin Voltage .....	21
5.3	Protection Functions .....	21
5.3.1	Loss of Ground Protection .....	22
5.3.2	Protection during Loss of Load or Loss of $V_S$ Condition .....	22
5.3.3	Undervoltage Behavior .....	24
5.3.4	Overvoltage Protection .....	25
5.3.5	Reverse Polarity Protection .....	25
5.3.6	Overload Protection .....	26
5.3.6.1	Activation of the Switch into Short Circuit (Short Circuit Type 1) .....	26
5.3.6.2	Short Circuit Appearance when the Device is already ON (Short Circuit Type 2) .....	26
5.3.6.3	Influence of the battery wire inductance .....	26
5.3.7	Temperature Limitation in the Power DMOS .....	28
5.4	Diagnostic Functions .....	29
5.4.1	IS Pin .....	29
5.4.2	SENSE Signal in Different Operation Modes .....	30
5.4.3	SENSE Signal in the Nominal Current Range .....	30
5.4.3.1	SENSE Signal Variation and Calibration .....	31
5.4.3.2	SENSE Signal Timing .....	34

5.4.3.3	SENSE Signal in Case of Short Circuit to $V_S$ .....	34
5.4.3.4	SENSE Signal in Case of Over Load .....	34
<b>6</b>	<b>Electrical Characteristics BTS50015-1TAD .....</b>	<b>35</b>
6.1	Electrical Characteristics Table .....	35
6.2	Typical Performance Characteristics .....	41
<b>7</b>	<b>Application Information .....</b>	<b>47</b>
7.1	Further Application Information .....	48
<b>8</b>	<b>Package Outlines .....</b>	<b>49</b>
<b>9</b>	<b>Revision History .....</b>	<b>50</b>

## List of Tables

Table 1	Product Summary .....	1
Table 2	Absolute Maximum Ratings .....	10
Table 3	Functional Range .....	14
Table 4	Thermal Resistance .....	15
Table 5	Sense Signal, Function of Operation Mode .....	30
Table 6	Electrical Characteristics: BTS50015-1TAD .....	35
Table 7	Bill of material .....	48

## List of Figures

Figure 1	Block Diagram for the BTS50015-1TAD .....	7
Figure 2	Pin Configuration .....	8
Figure 3	Voltage and Current Definition .....	9
Figure 4	Maximum Single Pulse Current vs. Pulse Time, $T_J \leq 150^\circ\text{C}$ , $T_{\text{PIN}} = 85^\circ\text{C}$ .....	12
Figure 5	Maximum Energy Dissipation for Inductive Switch OFF, $E_A$ vs. $I_L$ at $V_S = 13.5\text{ V}$ .....	13
Figure 6	Maximum Energy Dissipation Repetitive Pulse temperature derating.....	13
Figure 7	Typical Transient Thermal Impedance $Z_{\text{th(JA)}} = f(\text{time})$ for Different PCB Conditions .....	15
Figure 8	Switching a Resistive Load: Timing.....	16
Figure 9	Output Clamp.....	17
Figure 10	Switching an Inductance.....	17
Figure 11	Inverse Current Circuitry .....	19
Figure 12	Inverse Behavior - Timing Diagram.....	19
Figure 13	Switching in PWM .....	20
Figure 14	Input Pin Circuitry.....	21
Figure 15	Diagram of Diagnosis & Protection Block .....	22
Figure 16	Loss of Ground Protection with External Components .....	22
Figure 17	Loss of $V_S$ .....	23
Figure 18	Loss of Load .....	23
Figure 19	Undervoltage Behavior .....	24
Figure 20	Overvoltage Protection with External Components.....	25
Figure 21	Reverse Polarity Protection with External Components .....	26
Figure 22	Oscillations at VS pin .....	27
Figure 23	Consecutive short circuit events .....	27
Figure 24	RC Snubber circuits: between VS pin and module GND; between VS pin and device GND .....	28
Figure 25	Overload Protection .....	29
Figure 26	Diagnostic Block Diagram.....	30
Figure 27	Current Sense for Nominal and Overload Condition .....	31
Figure 28	Improved Current Sense Accuracy after 2-Point Calibration .....	33
Figure 29	Fault Acknowledgement .....	34
Figure 30	Application Diagram with BTS50015-1TAD.....	47
Figure 31	PG-TO-263-7-8 (RoHS-Compliant).....	49

**Block Diagram**

**2 Block Diagram**

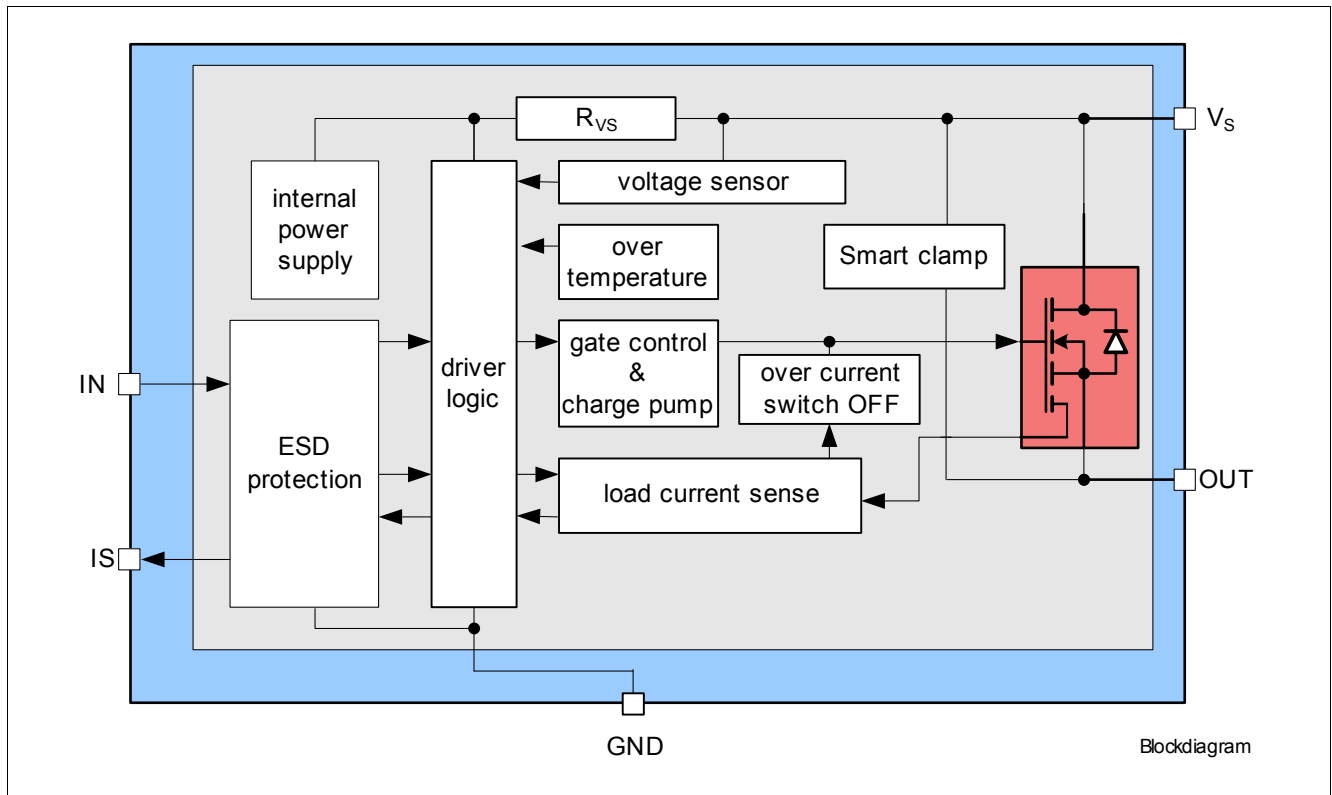
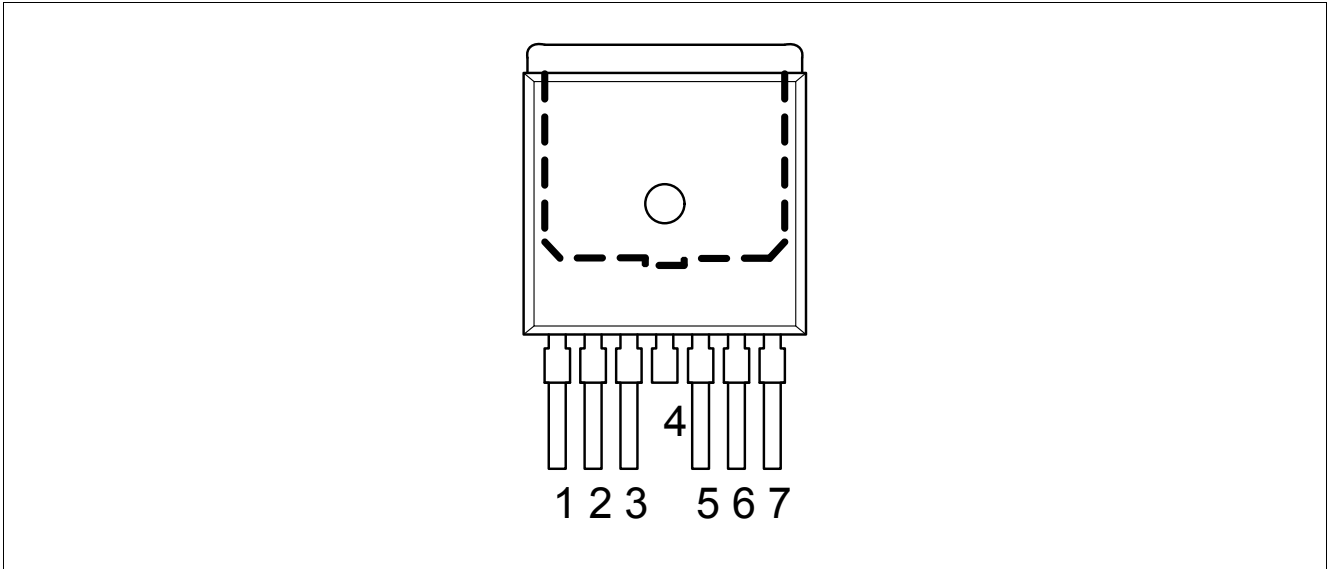

**Figure 1 Block Diagram for the BTS50015-1TAD**

**Pin Configuration**

**3 Pin Configuration**

**3.1 Pin Assignment**



**Figure 2 Pin Configuration**

**3.2 Pin Definitions and Functions**

Pin	Symbol	Function
1	GND	<b>GrouND</b> ; Signal Ground
2	IN	<b>INput</b> ; Digital signal to switch ON channel (“high” active)
3	IS	<b>Sense</b> ; Analog/Digital signal for diagnosis, if not used: left open
4, Cooling tab	VS	<b>Supply Voltage</b> ; Battery voltage
5, 6, 7	OUT	<b>OUTput</b> ; Protected high side power output channel <sup>1)</sup>

1) All output pins are internally connected and they also have to be connected together on the PCB. Not shorting all outputs on PCB will considerably increase the ON-state resistance and decrease the current sense / overcurrent tripping accuracy. PCB traces have to be designed to withstand the maximum current.



Pin Configuration

3.3 Voltage and Current Definition

Figure 3 shows all terms used in this data sheet, with associated convention for positive values.

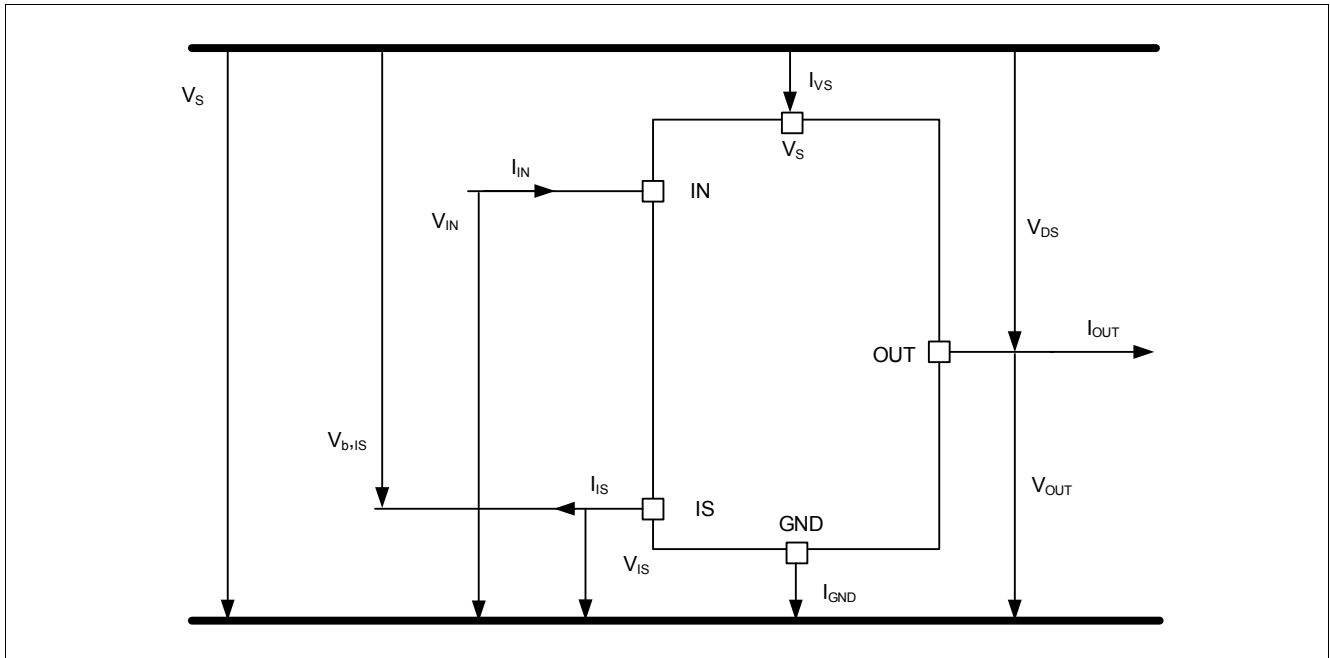

Figure 3 Voltage and Current Definition

**General Product Characteristics**

**4 General Product Characteristics**

**4.1 Absolute Maximum Ratings**

**Table 2 Absolute Maximum Ratings<sup>1)</sup>**

$T_j = -40^{\circ}\text{C}$  to  $+150^{\circ}\text{C}$ ; (unless otherwise specified)

Parameter	Symbol	Values			Unit	Note or Test Condition	Number
		Min.	Typ.	Max.			
<b>Supply Voltages</b>							
Supply Voltage	$V_S$	-0.3	-	28	V	-	P_4.1.1
Reverse Polarity Voltage	$-V_{S(\text{REV})}$	0	-	16	V	<sup>2)</sup> $t < 2$ min $T_A = 25^{\circ}\text{C}$ $R_L \geq 0.5 \Omega$	P_4.1.2
Load Dump Voltage	$V_{\text{BAT(LD)}}$	-	-	45	V	<sup>3)</sup> $R_I = 2 \Omega$ $R_L = 2.2 \Omega$ $R_{\text{IS}} = 1 \text{ k}\Omega$ $R_{\text{IN}} = 4.7 \text{ k}\Omega$	P_4.1.5
<b>Short Circuit Capability</b>							
Supply Voltage for Short Circuit Protection	$V_{S(\text{SC})}$	5	-	20	V	<sup>4)</sup> $R_{\text{ECU}} = 20 \text{ m}\Omega$ $L_{\text{ECU}} = 1 \mu\text{H}$ $R_{\text{cable}} = 6 \text{ m}\Omega/\text{m}$ $L_{\text{cable}} = 1 \mu\text{H}/\text{m}$ $l =$ to 5 m R, C as shown in <b>Figure 30</b> See <b>Chapter 5.3</b>	P_4.1.3
Short Circuit is Permanent: IN Pin Toggles Short Circuit (SC type 1)	$n_{\text{RSC1}}$	-	-	1 million (Grade A)	-	<sup>5)</sup>	P_4.1.4
<b>GND Pin</b>							
Current through GND pin	$I_{\text{GND}}$	-15 - <sup>6)</sup>	- -	$10^7$ 15	mA	- $t \leq 2$ min	P_4.1.6
<b>Input Pin</b>							
Voltage at IN pin	$V_{\text{IN}}$	-0.3	-	$V_S$	V	-	P_4.1.7
Current through IN pin	$I_{\text{IN}}$	-5 -5	- -	5 $50^6)$	mA	- $t \leq 2$ min	P_4.1.8
Maximum Retry Cycle Rate in Fault Condition	$f_{\text{fault}}$	-	-	1	Hz	-	P_4.1.9

**General Product Characteristics**

**Table 2 Absolute Maximum Ratings<sup>1)</sup> (cont'd)**

$T_J = -40^\circ\text{C}$  to  $+150^\circ\text{C}$ ; (unless otherwise specified)

Parameter	Symbol	Values			Unit	Note or Test Condition	Number
		Min.	Typ.	Max.			
<b>Sense Pin</b>							
Voltage at IS pin	$V_{IS}$	-0.3	-	$V_S$	V	-	P_4.1.10
Current through IS Pin	$I_{IS}$	-15 - <sup>6)</sup>	-	$10^7)$ 15	mA	- $t \leq 2$ min	P_4.1.11
<b>Power Stage</b>							
Maximum Energy Dissipation by Switching Off Inductive Load Single Pulse over Lifetime	$E_{AS}$	-	-	3000	mJ	$V_S = 13.5$ V $I_L = I_{L(NOM)} = 33$ A $T_{J(0)} \leq 150^\circ\text{C}$ See <b>Figure 5</b>	P_4.1.12
Maximum Energy Dissipation Repetitive Pulse	$E_{AR}$	-	-	550	mJ	<sup>8)</sup> $V_S = 13.5$ V $I_L = I_{L(NOM)} = 33$ A $T_{J(0)} \leq 105^\circ\text{C}$ See <b>Figure 5</b>	P_4.1.13
Maximum Energy Dissipation Repetitive Pulse	$E_{AR}$	-	-	200	mJ	<sup>8)</sup> $V_S = 13.5$ V $I_L = 80$ A $T_{J(0)} \leq 105^\circ\text{C}$ See <b>Figure 5</b>	P_4.1.14
Average Power Dissipation	$P_{TOT}$	-	-	200	W	$T_C = -40^\circ\text{C}$ to $150^\circ\text{C}$	P_4.1.15
Voltage at OUT Pin	$V_{OUT}$	-64	-	-	V	-	P_4.1.21
<b>Temperatures</b>							
Junction Temperature	$T_J$	-40	-	150	$^\circ\text{C}$	-	P_4.1.16
Dynamic Temperature Increase while Switching	$\Delta T_J$	-	-	60	K	See <b>Chapter 5.3</b>	P_4.1.17
Storage Temperature	$T_{STG}$	-55	-	150	$^\circ\text{C}$	-	P_4.1.18
<b>ESD Susceptibility</b>							
ESD Susceptibility (all Pins)	$V_{ESD(HBM)}$	-2	-	2	kV	HBM <sup>9)</sup>	P_4.1.19
ESD Susceptibility OUT Pin vs. GND / $V_S$	$V_{ESD(HBM)}$	-4	-	4	kV	HBM <sup>9)</sup>	P_4.1.20

1) Not subject to production test, specified by design.

2) The device is mounted on a FR4 2s2p board according to Jedec JESD51-2,-5,-7 at natural convection.

3)  $V_{S(LD)}$  is setup without DUT connected to the generator per ISO 7637-1.

4) In accordance to AEC Q100-012, Figure-1 Test Circuit.

5) In accordance to AEC Q100-012, Chapter 3 conditions. Short circuit conditions deviating from AEC Q100-012 may influence the specified short circuit cycle number in the data sheet.

6) The total reverse current (sum of  $I_{GND}$ ,  $I_{IS}$  and  $-I_{IN}$ ) is limited by  $-V_{S(REV)\_max}$  and  $R_{VS}$ .

7)  $T_C \leq 125^\circ\text{C}$

8) Setup for EAR equivalent to short circuit test AEC Q100-012: Grade A (exceeding  $10^6$  cycles, parameter deviations are possible)

9) ESD susceptibility, HBM according to ANSI/ESDA/JEDEC JS-001.

**General Product Characteristics**

**Notes**

1. Stresses above the ones listed here may cause permanent damage to the device. Exposure to absolute maximum rating conditions for extended periods may affect device reliability.
2. Integrated protection functions are designed to prevent IC destruction under fault conditions described in the data sheet. Fault conditions are considered as “outside” normal operating range. Protection functions are not designed for continuous repetitive operation.

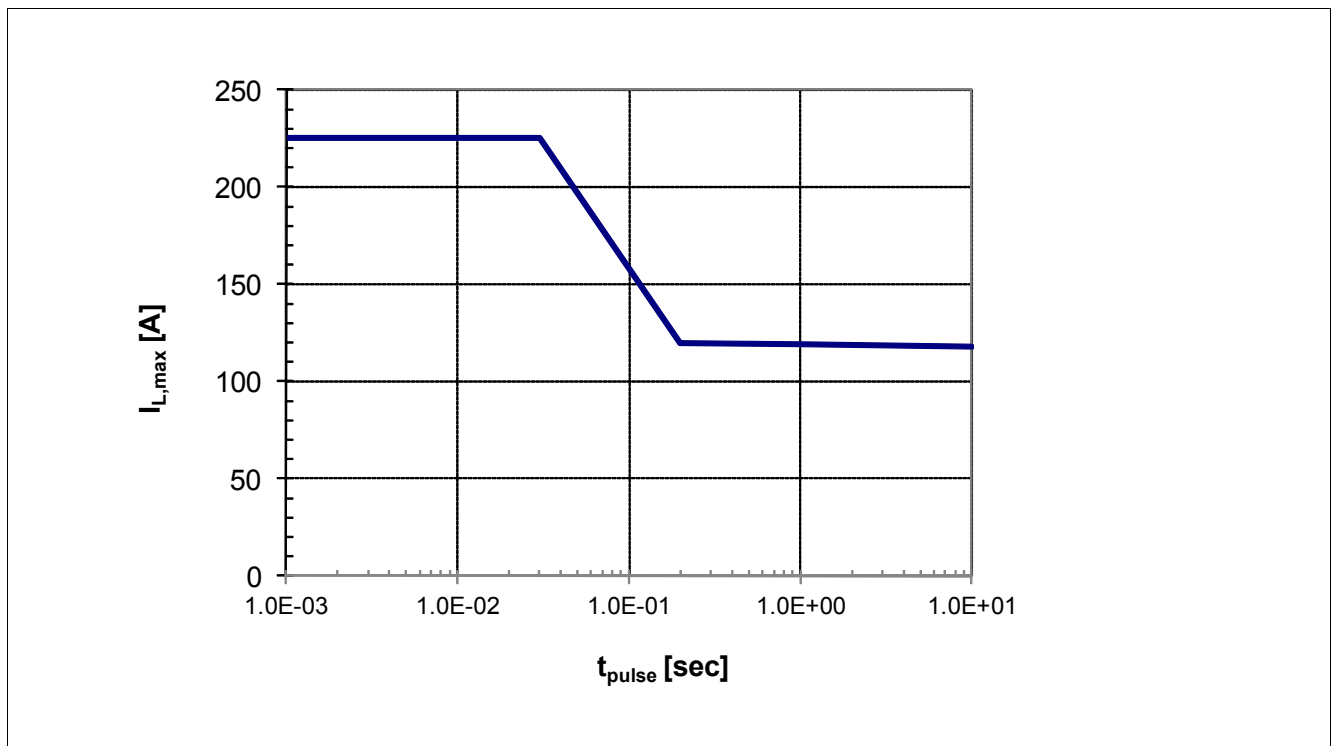

**Figure 4** Maximum Single Pulse Current vs. Pulse Time,  $T_J \leq 150^\circ\text{C}$ ,  $T_{PIN} = 85^\circ\text{C}$

*Note:* Above diagram shows the maximum single pulse current that can be maintained by the internal power stage bond wires for a given pulse time  $t_{pulse}$ . The maximum reachable current may be smaller depending on the device current limitation level. The maximum reachable pulse time may be shorter due to thermal protection of the device.  $T_{PIN}$  is the temperature of pins 5, 6 and 7.

**General Product Characteristics**

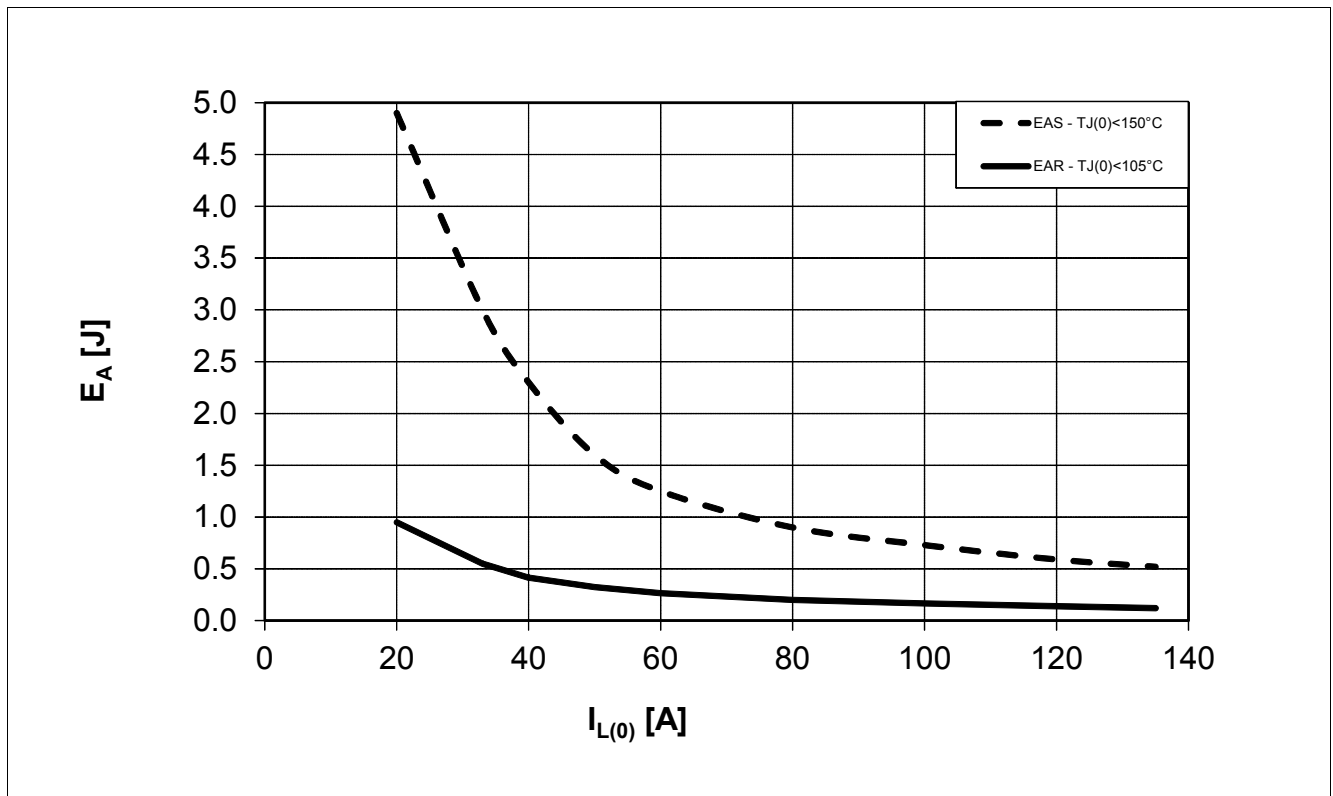

**Figure 5** Maximum Energy Dissipation for Inductive Switch OFF,  $E_A$  vs.  $I_L$  at  $V_S = 13.5\text{ V}$

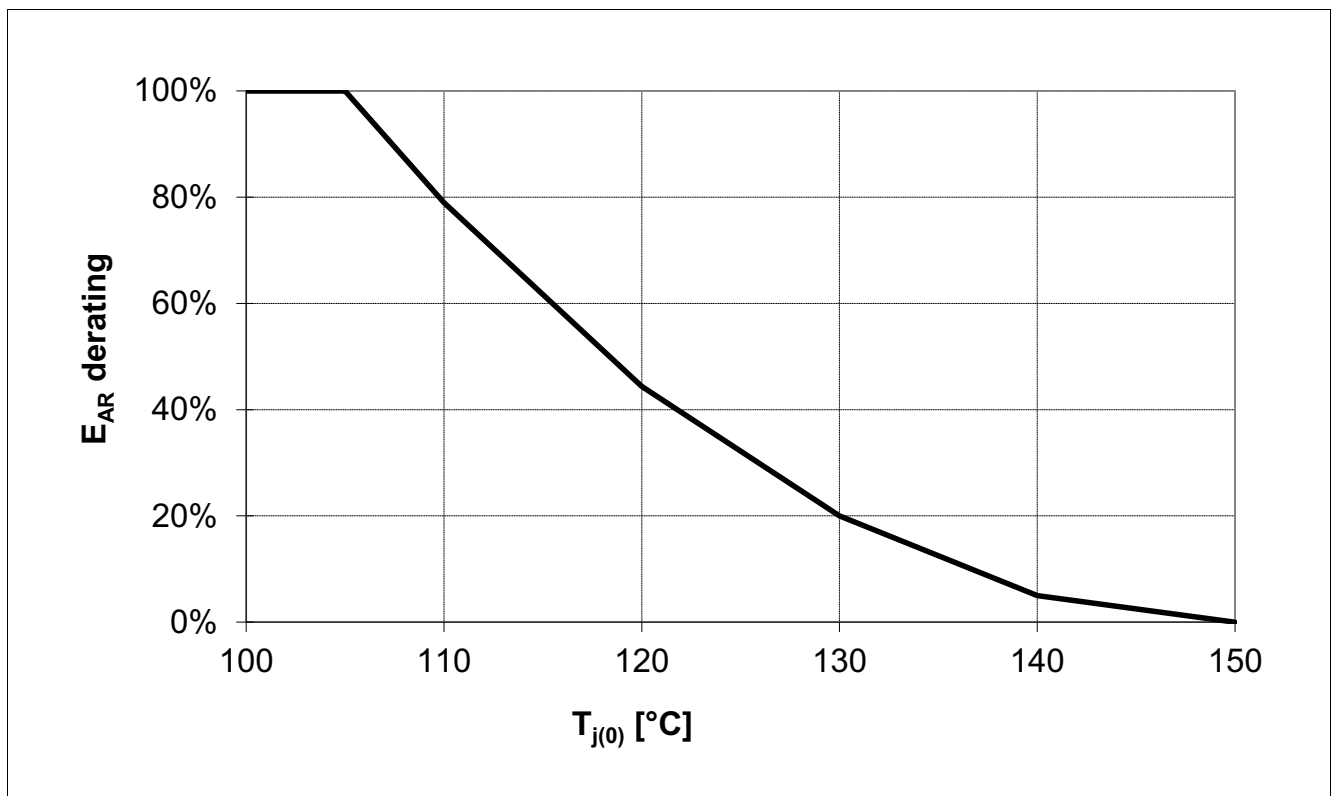

**Figure 6** Maximum Energy Dissipation Repetitive Pulse temperature derating

**General Product Characteristics**

**4.2 Functional Range**

**Table 3 Functional Range**

Parameter	Symbol	Values			Unit	Note or Test Condition	Number
		Min.	Typ.	Max.			
Supply Voltage Range for Nominal Operation	$V_{S(NOM)}$	8	–	18	V	–	P_4.2.1
Supply Voltage Range for Extended Operation	$V_{S(EXT)}$	5.3	–	28	V	<sup>1)</sup> $V_{IN} \geq 2.2\text{ V}$ $I_L \leq I_{L(NOM)}$ $T_J \leq 25^\circ\text{C}$ Parameter deviations possible	P_4.2.2
	$V_{S(EXT)}$	5.5	–	28	V	<sup>1)</sup> $V_{IN} \geq 2.2\text{ V}$ $I_L \leq I_{L(NOM)}$ $T_J = 150^\circ\text{C}$ Parameter deviations possible	
Supply Voltage Range for Extended Operation Dynamic Undervoltage Capability	$V_{S(EXT,DYN)}$	3.2 <sup>2)</sup>	–	–	V	<sup>1)</sup> acc. to ISO 7637	P_4.2.3
Supply Undervoltage Shutdown	$V_{S(UV)}$	–	–	4.5	V	<sup>1)</sup> $V_{IN} \geq 2.2\text{ V}$ $R_L = 270\ \Omega$ $V_S$ decreasing See <a href="#">Figure 19</a>	P_4.2.4
Slewrates at OUT	$ dV_{DS}/dt $	–	–	10	V/ $\mu\text{s}$	<sup>1)</sup> $ V_{DS}  < 3\text{ V}$ See <a href="#">Chapter 5.1.4</a>	P_4.2.7
Slewrates at OUT	$ dV_{DS}/dt $	–	–	0.2	V/ $\mu\text{s}$	<sup>1)</sup> $V_{S(EXT)} < V_S < 8\text{ V}$ $0 < V_{DS} < 1\text{ V}$ $t < t_{ON(DELAY)}$ See <a href="#">Chapter 5.1.4</a>	P_4.2.8

1) Not subject to production test. Specified by design

2)  $T_A = 25^\circ\text{C}$ ;  $R_L = 0.5\ \Omega$ ; pulse duration 6 ms; cranking capability is depending on load and must be verified under application conditions

*Note: Within the functional or operating range, the IC operates as described in the circuit description. The electrical characteristics are specified within the conditions given in the Electrical Characteristics table.*

**General Product Characteristics**

**4.3 Thermal Resistance**

Note: This thermal data was generated in accordance with JEDEC JESD51 standards. For more information, go to [www.jedec.org](http://www.jedec.org).

**Table 4 Thermal Resistance**

Parameter	Symbol	Values			Unit	Note or Test Condition	Number
		Min.	Typ.	Max.			
Junction to Case	$R_{thJC}$	–	–	0.5	K/W	1)	P_4.3.1
Junction to Ambient	$R_{thJA(2s2p)}$	–	20	–	K/W	1)2)	P_4.3.2
Junction to Ambient	$R_{thJA}$	–	70	–	K/W	1)3)	P_4.3.3

- 1) Not subject to production test, specified by design.
- 2) Specified  $R_{thJA}$  value is according to Jecdec JESD51-2,-5,-7 at natural convection on FR4 2s2p board; The Product (Chip+Package) was simulated on a 76.2 × 114.3 × 1.5 mm board with 2 inner copper layers (2 × 70 μm Cu, 2 × 35 μm Cu). Where applicable a thermal via array under the exposed pad contacted the first inner copper layer.  $T_A = 25^\circ\text{C}$ . Device is dissipating 2 W power.
- 3) Specified  $R_{thJA}$  value is according to Jecdec JESD51-2,-5,-7 at natural convection on FR4 1s0p board; the Product (Chip+Package) was simulated on a 76.2 × 114.3 × 1.5 mm board with only one top copper layer 1 × 70 μm.  $T_A = 25^\circ\text{C}$ . Device is dissipating 2 W power.

Figure 7 is showing the typical thermal impedance of BTS50015-1TAD mounted according to JEDEC JESD51-2,-5,-7 at natural convection on FR4 1s0p and 2s2p boards.

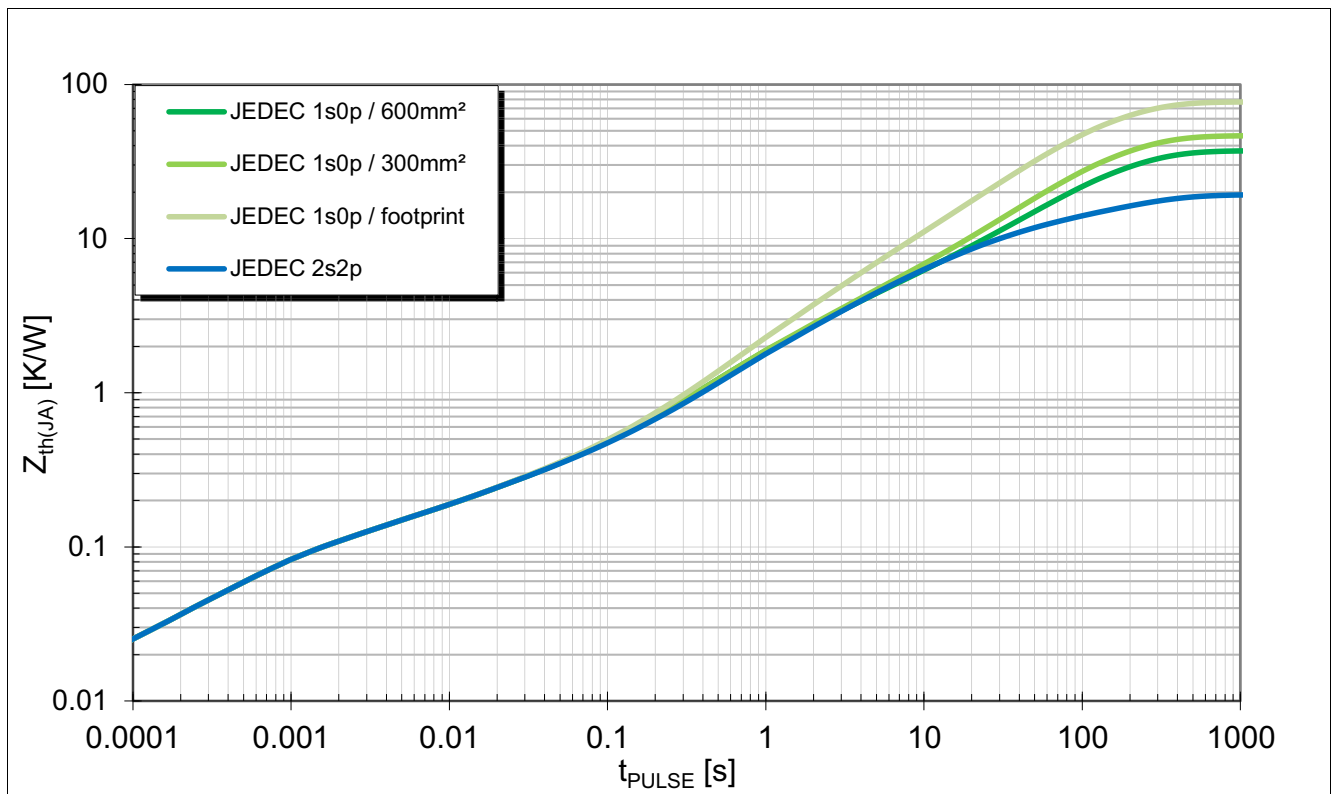

**Figure 7 Typical Transient Thermal Impedance  $Z_{th(JA)} = f(\text{time})$  for Different PCB Conditions**

**Functional Description**

**5 Functional Description**

**5.1 Power Stage**

The power stage is built by a N-channel power MOSFET (DMOS) with charge pump.

**5.1.1 Output ON-State Resistance**

The ON-state resistance  $R_{DS(ON)}$  depends on the supply voltage as well as the junction temperature  $T_J$ . **Page 42** shows the dependencies in terms of temperature and supply voltage, for the typical ON-state resistance. The behavior in reverse polarity is described in **Chapter 5.3.5**.

A HIGH signal (see **Chapter 5.2**) at the input pin causes the power DMOS to switch ON with a dedicated slope, which is optimized in terms of EMC emission.

**5.1.2 Switching Resistive Loads**

**Figure 8** shows the typical timing when switching a resistive load. The power stage has a defined switching behavior. Defined slew rates results in lowest EMC emission at minimum switching losses.

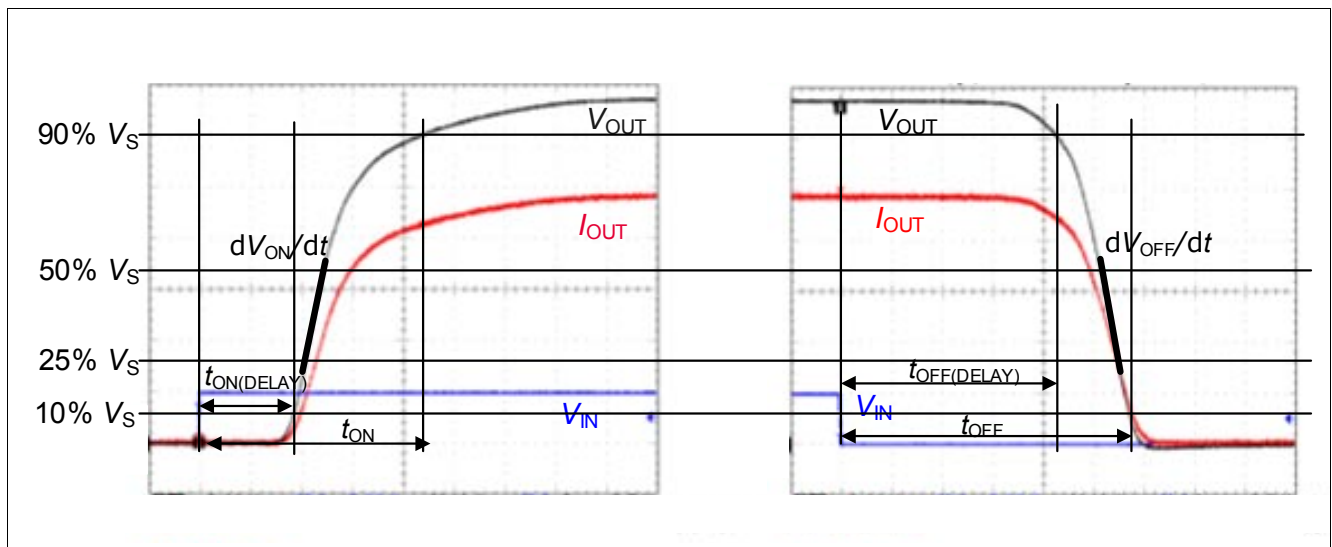

**Figure 8 Switching a Resistive Load: Timing**

**5.1.3 Switching Inductive Loads**

**5.1.3.1 Output Clamping**

When switching OFF inductive loads with high side switches, the voltage  $V_{OUT}$  drops below ground potential, because the inductance intends to continue driving the current. To prevent the destruction of the device due to high voltages, there is a Infineon® SMART CLAMPING mechanism implemented that keeps negative output voltage to a certain level ( $V_S - V_{DS(CL)}$ ). Please refer to **Figure 9** and **Figure 10** for details. Nevertheless, the maximum allowed load inductance remains limited.



**Functional Description**

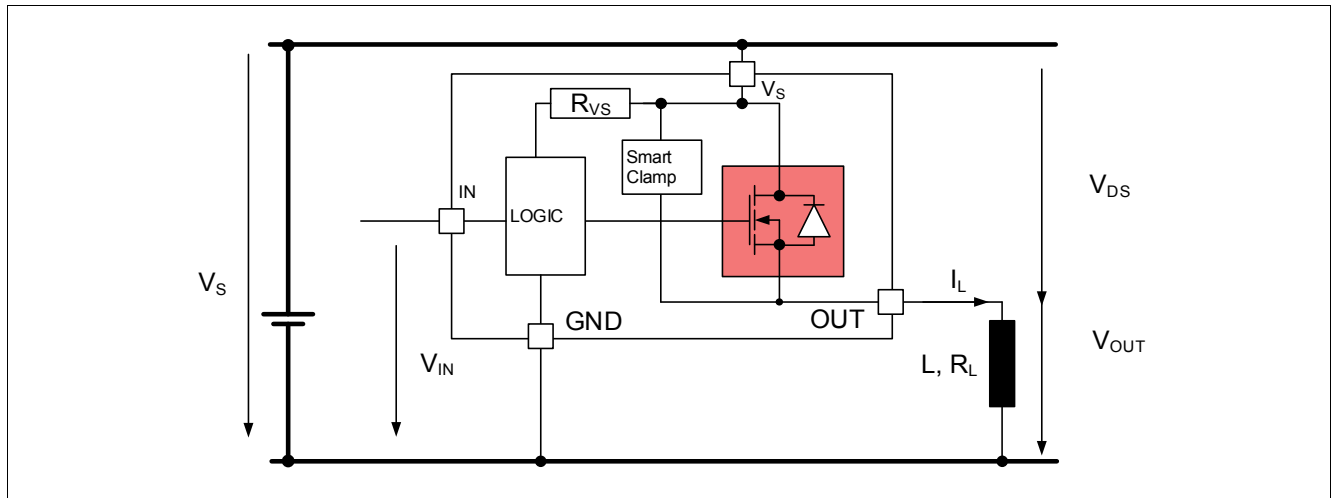

**Figure 9 Output Clamp**

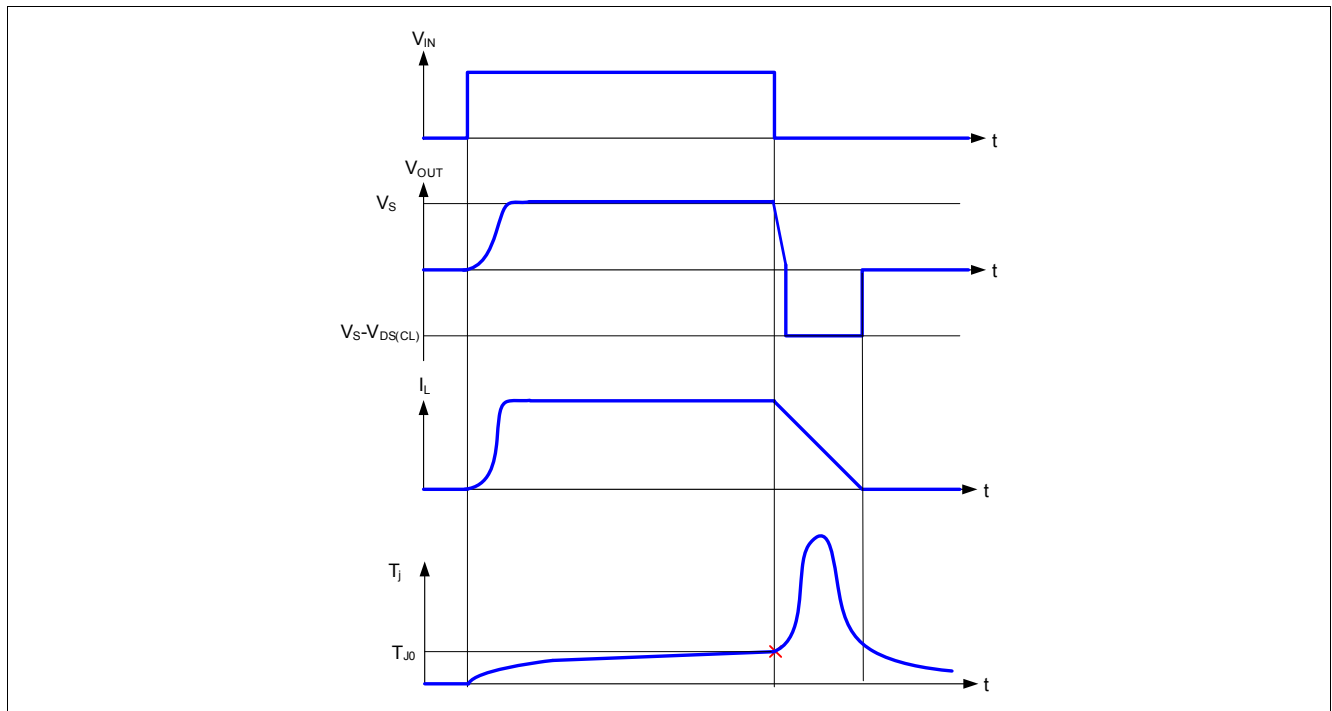

**Figure 10 Switching an Inductance**

The BTS50015-1TAD provides Infineon® SMART CLAMPING functionality. To increase the energy capability for single operation, the clamp voltage  $V_{DS(CL)}$  increases with junction temperature  $T_j$  and with load current  $I_L$ . Refer to [Page 44](#).

**5.1.3.2 Maximum Load Inductance**

During demagnetization of inductive loads, energy must be dissipated in the BTS50015-1TAD. This energy can be calculated with following equation:

$$E = V_{DS(CL)} \times \frac{L}{R_L} \times \left[ \frac{V_S - V_{DS(CL)}}{R_L} \times \ln \left( 1 - \frac{R_L \times I_L}{V_S - V_{DS(CL)}} \right) + I_L \right] \tag{5.1}$$

## Functional Description

Following equation simplifies under the assumption of  $R_L = 0 \Omega$ .

$$E = \frac{1}{2} \times L \times I_L^2 \times \left( 1 - \frac{V_S}{V_S - V_{DS(CL)}} \right) \quad (5.2)$$

The energy, which is converted into heat, is limited by the thermal design of the component. See [Figure 5](#) for the maximum allowed energy dissipation as function of the load current.

### 5.1.4 Switching Active Loads

When switching generative or electronic loads such as motors or secondary ECUs which have the ability to feed back voltage disturbances to the OUT pins, special attention is required about the resulting absolute and dynamic voltage  $V_{DS}$  between VS pin and OUT pins.

To maintain device functionality it is required to limit the maximum positive or negative slew rate of

$V_{DS} = V_S - V_{OUT}$  below  $|dV_{DS}/dt|$  (parameter [P\\_4.2.7](#)).

In case the device operates at low battery voltage ( $V_S < 8 V$ ) where the load feeds back a positive output voltage reaching almost VS potential ( $0 < V_{DS} < 1 V$ ), it has to be ensured that for each activation (turn-on event), where the device is commanded on by applying  $V_{IN(H)}$  at IN pin, a maximum positive or negative slew rate of  $V_{DS}$  below  $|dV_{DS}/dt|$  (parameter [P\\_4.2.8](#)) will not be exceeded until  $t_{ON(DELAY)}$  has expired (maximum 150  $\mu s$  after turn-on command).

For loads that generate steady or dynamic voltage at the OUT pins which is higher than voltage at VS pin please consider [Chapter 5.1.5](#).

**Functional Description**

**5.1.5 Inverse Current Capability**

In case of inverse current, meaning a voltage  $V_{OUT(INV)}$  at the output higher than the supply voltage  $V_S$ , a current  $I_{L(INV)}$  will flow from output to  $V_S$  pin via the body diode of the power transistor (please refer to **Figure 11**). In case the IN pin is HIGH, the power DMOS is already activated and will continue to remain in ON state during the inverse event. In case, the input goes from “L” to “H”, the DMOS will be activated even during an inverse event. Under inverse condition, the device is not overtemperature / overload protected. During inverse mode at ON the sense pin will provide a leakage current of less or equal to  $I_{IS0}$ . Due to the limited speed of INV comparator, the inverse duration needs to be limited.

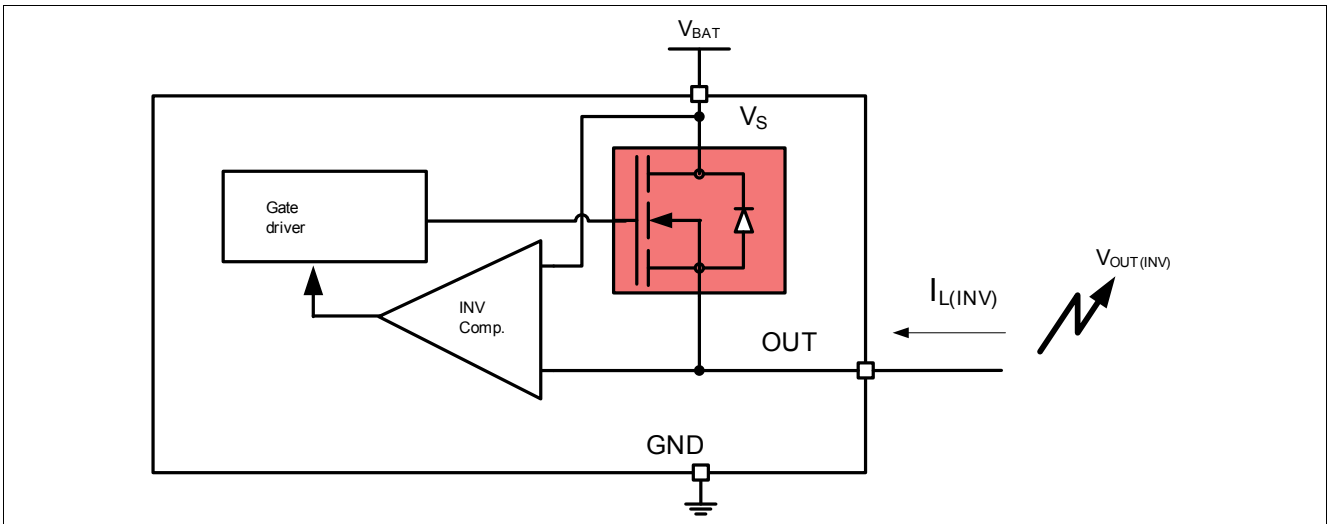

**Figure 11 Inverse Current Circuitry**

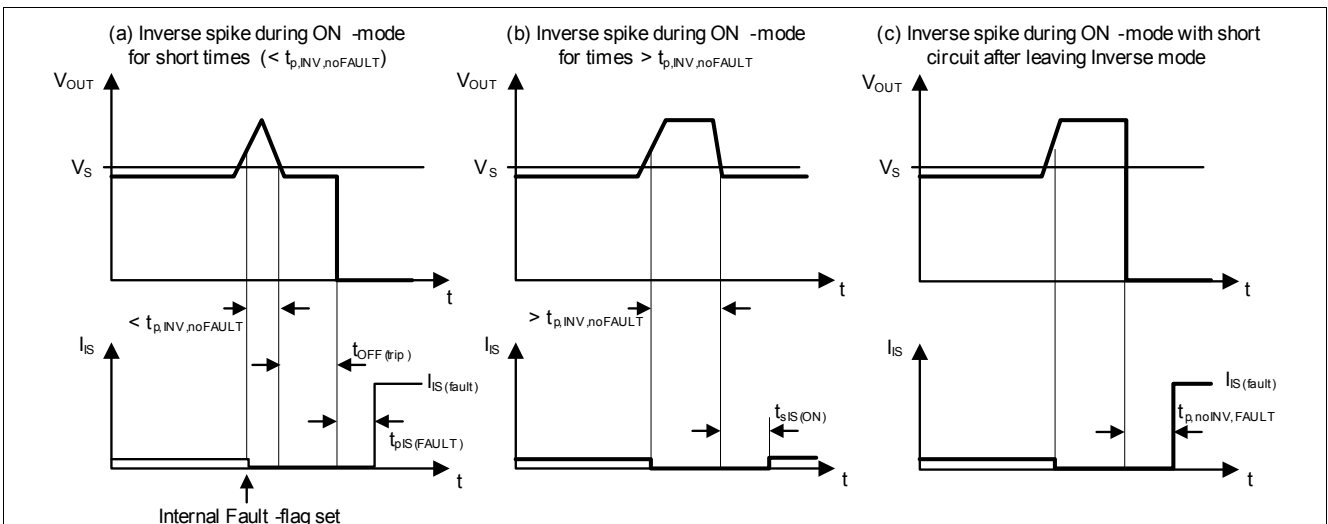

**Figure 12 Inverse Behavior - Timing Diagram**

**Functional Description**

**5.1.6 PWM Switching**

The switching losses during this operation should be properly considered (see following equation):

$$P_{TOTAL} = (\text{switching\_ON\_energy} + \text{switching\_OFF\_energy} + I_L^2 \times R_{DS(ON)} \times t_{DC}) / \text{period}$$

PWM switching application slightly above  $t_{IN(RESETDELAY)}$  parameter (see **Figure 25**) with calculated power dissipation  $P_{TOTAL} > P_{TOT}$  parameter limit causes an effective increase in  $T_{J(TRIP)}$  parameter.

In the event of a fault condition it has to be ensured, that the PWM frequency will not exceed a maximum retry frequency of  $f_{FAULT}$  (parameter **P\_4.1.9**). With this measure the short circuit robustness  $n_{RSC1}$  (parameter **P\_4.1.4**) can be utilized. Operation at nominal PWM frequency can only be restored, once the fault condition is overcome.

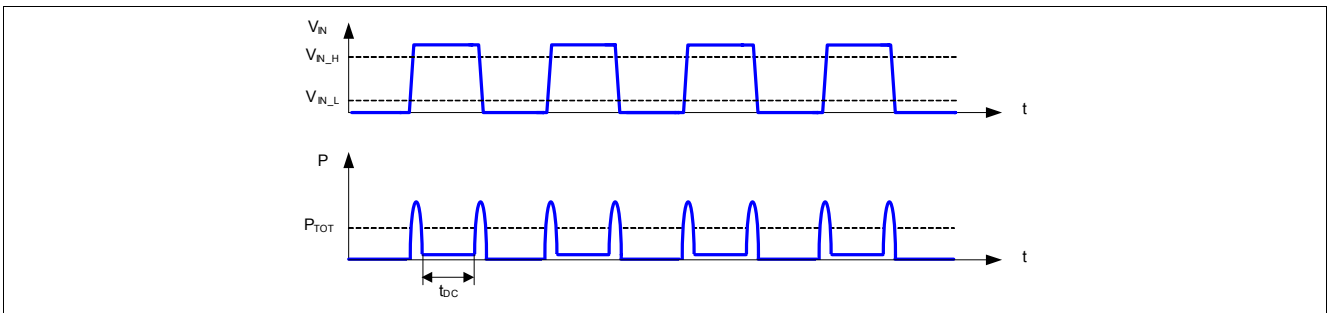

**Figure 13 Switching in PWM**

**5.1.7 Advanced switch-off behavior**

In order to reduce device stress when switching OFF critical loads and/or critical load conditions, the device provides an advanced switch off functionality which results in a typically ten times faster switch off behavior. This fast switch off functionality is triggered by one the following conditions:

- The device is commanded off by applying  $V_{IN(L)}$  at the IN pin. During the switch OFF operation the OUT pins' voltage in respect to GND pin drops to typically -3 V or below (typically  $V_{OUT} - V_{GND} \leq -3 V$ ).
- The device is commanded on or is already in on-state. The device then detects a short circuit condition ( $I_L \geq I_{CL(0)}$ ) and initiates a protective switch off. Please refer to **Chapter 5.3.6.1** and **Chapter 5.3.6.2** for details.

**Functional Description**

**5.2 Input Pins**

**5.2.1 Input Circuitry**

The input circuitry is compatible with 3.3 V and 5 V microcontrollers or can be directly driven by  $V_S$ . The concept of the input pin is to react to voltage threshold. With the Schmitt trigger, the output is either ON or OFF. **Figure 14** shows the electrical equivalent input circuitry.

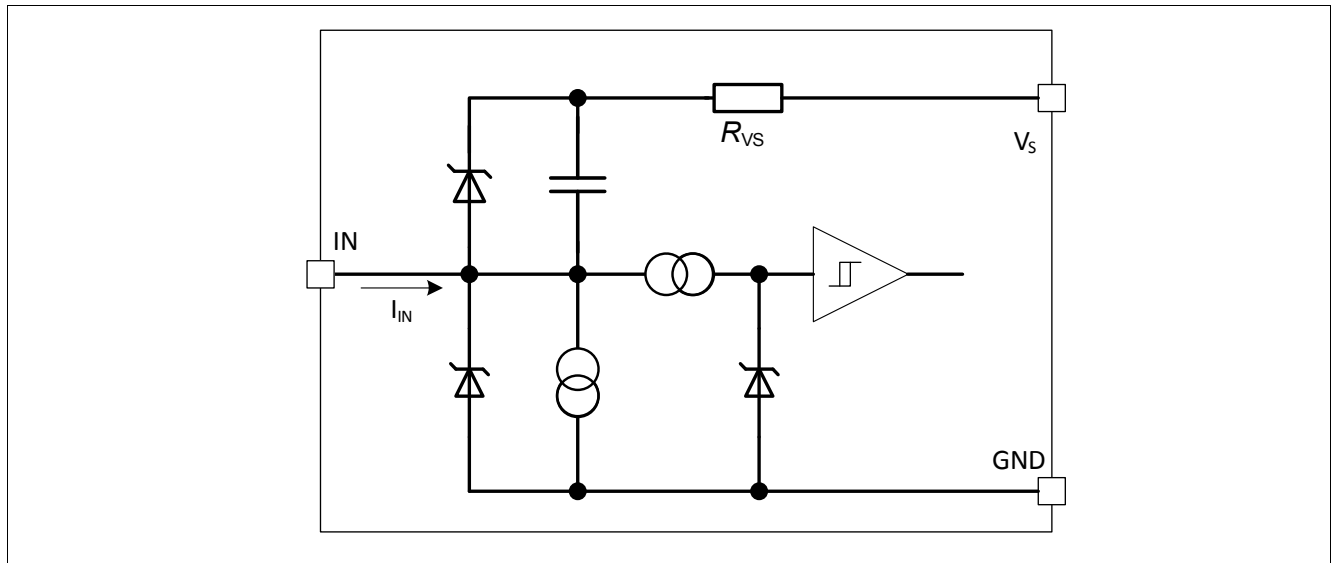

**Figure 14** Input Pin Circuitry

**5.2.2 Input Pin Voltage**

The IN uses a comparator with hysteresis. The switching ON / OFF takes place in a defined region, set by the threshold  $V_{IN(L) \text{ Max}}$  and  $V_{IN(H) \text{ Min}}$ . The exact value where ON and OFF take place depends on the process, as well as the temperature. To avoid cross talk and parasitic turn ON and OFF, an hysteresis is implemented. This ensures immunity to noise.

**5.3 Protection Functions**

The device provides embedded protective functions. Integrated protection functions are designed to prevent the destruction of the IC from fault conditions described in the data sheet. Fault conditions are considered as “outside” normal operating range. Protection functions are designed neither for continuous nor for repetitive operation.

**Figure 15** describes the typical functionality of the diagnosis and protection block.

**Functional Description**

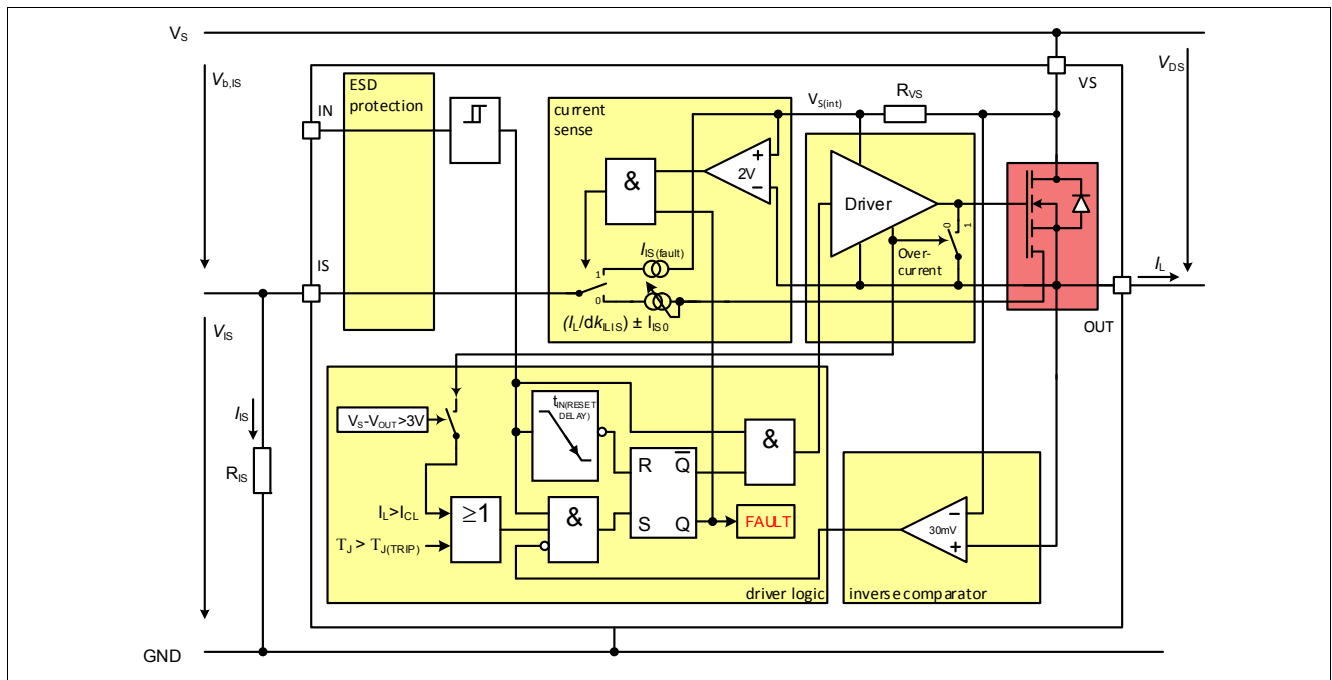

**Figure 15** Diagram of Diagnosis & Protection Block

**5.3.1 Loss of Ground Protection**

In case of loss of module or device ground, where the load remains connected to ground, the device protects itself by automatically turning OFF (when it was previously ON) or remains OFF, regardless of the voltage applied at IN pin. It is recommended to use input resistors between the microcontroller and the BTS50015-1TAD to ensure switching OFF of channel. In case of loss of module or device ground, a current ( $I_{OUT(GND)}$ ) can flow out of the DMOS. **Figure 16** sketches the situation.

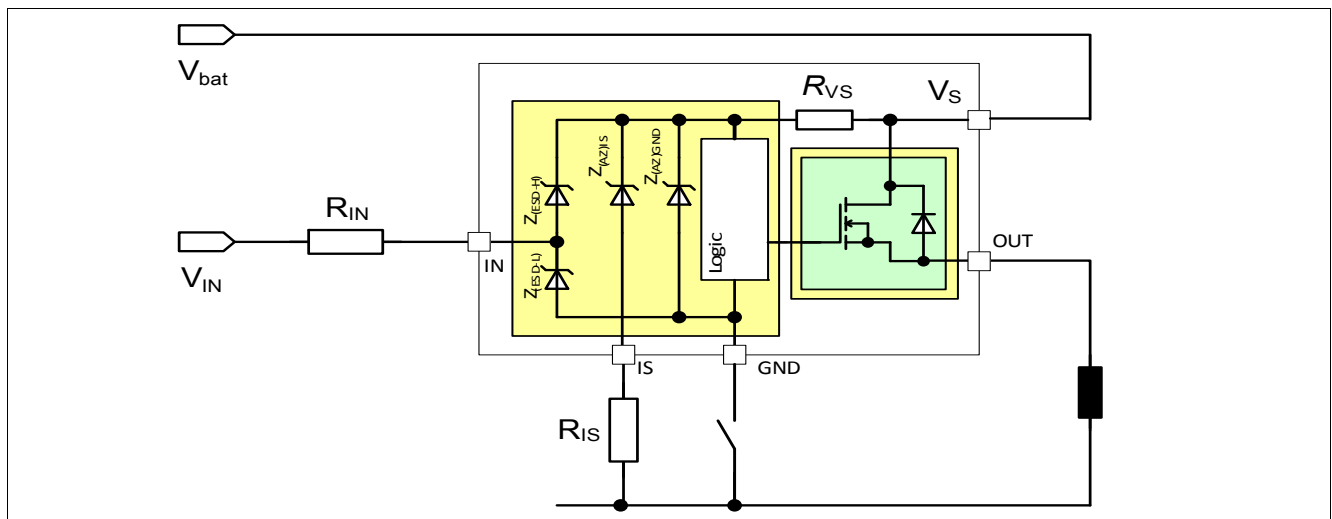

**Figure 16** Loss of Ground Protection with External Components

**5.3.2 Protection during Loss of Load or Loss of  $V_S$  Condition**

In case of loss of load with charged primary inductances the supply voltage transient has to be limited. It is recommended to use a Zener diode, a varistor or  $V_S$  clamping power switches with connected loads in parallel. The voltage must be limited according to the minimum value of the parameter 6.1.33 indicated in **Table 6**.

**Functional Description**

In case of loss of  $V_S$  connection with charged inductive loads, a current path with sufficient load current capability has to be provided, to demagnetize the charged inductances. It is recommended to protect the device using a Zener diode together with a diode ( $V_{Z1} + V_{D1} < 16\text{ V}$ ), with path (A) or path (B) as shown in **Figure 17**.

For a proper restart of the device after loss of  $V_S$ , the input voltage must be delayed compared to the supply voltage ramp up. This can be realized by a capacitor between IN and GND (see **Figure 30**).

For higher clamp voltages, currents through all pins have to be limited according to the maximum ratings. Please see **Figure 17** and **Figure 18** for details.

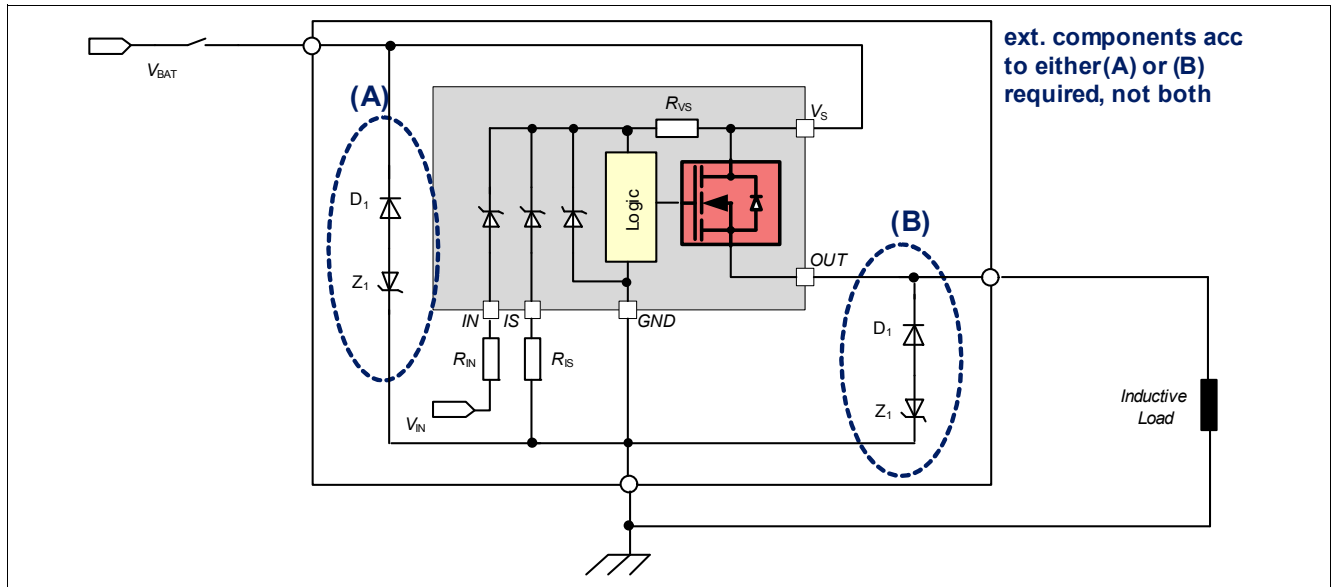

**Figure 17 Loss of  $V_S$**

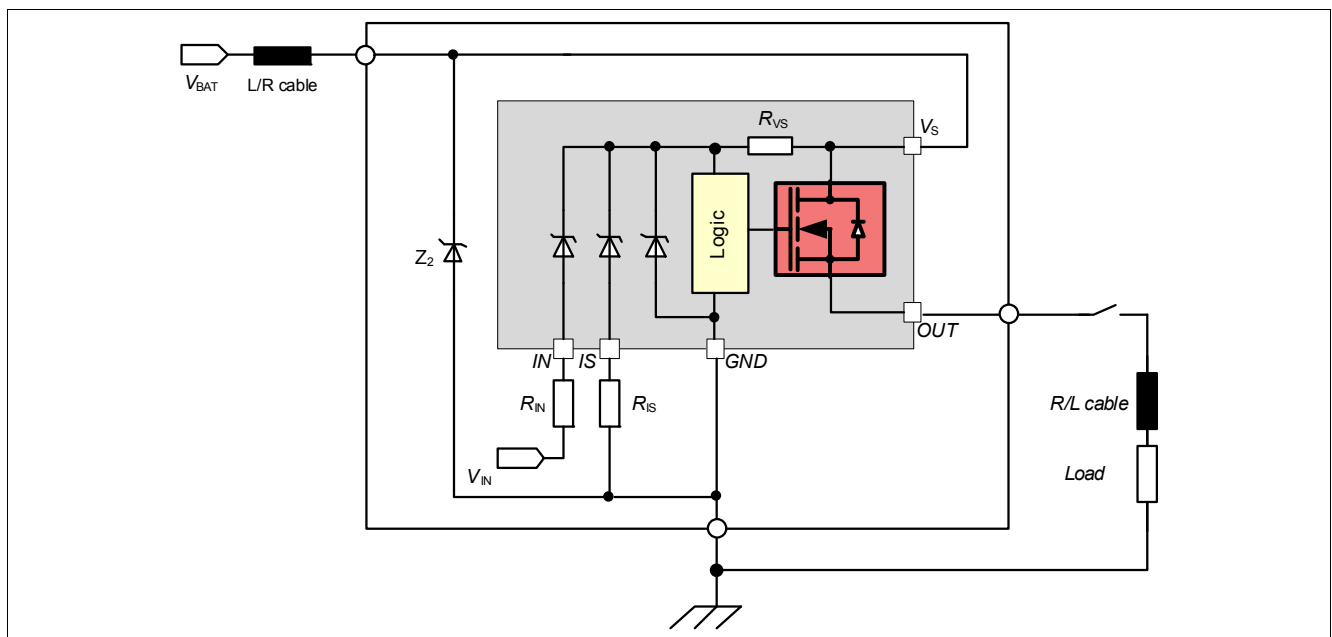

**Figure 18 Loss of Load**

**Functional Description**

**5.3.3 Undervoltage Behavior**

If the device is already ON and the power supply decreases but remains above the  $V_{S(UV)}$ , no effect is observed and the device keeps on working normally (case 1, **Figure 19**)

If the power supply falls below the  $V_{S(UV)}$  but remains above the  $V_{S(EXT,DYN)}$ , the device turns off, but it turns automatically on again when the power supply goes above  $\text{Min. } V_{S(EXT)}$  (case 2, **Figure 19**).

In case the power supply becomes lower than  $V_{S(EXT,DYN)}$ , the device turns off and can be switched on again only after a reset signal at the IN pin, provided that the power supply is higher than  $\text{Min. } V_{S(EXT)}$  (case 3, **Figure 19**).

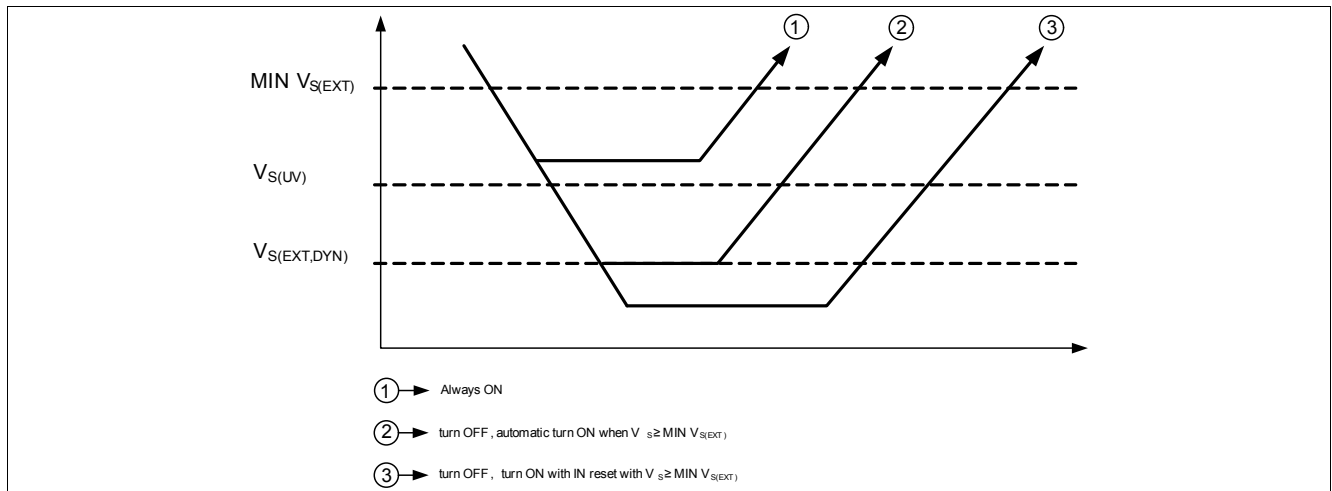

**Figure 19 Undervoltage Behavior**



**Functional Description**

**5.3.4 Overvoltage Protection**

In case  $V_{S(SC\_max)} < V_S < V_{DS(CL)}$ , the device will switch ON/OFF normally as in the nominal voltage range. Parameters may deviate from the specified limits and lifetime is reduced. This specially impacts the short circuit robustness, as well as the maximum energy  $E_{AS}$  and  $E_{AR}$  the device can handle.

The BTS50015-1TAD provides Infineon® SMART CLAMPING functionality, which suppresses excessive transient overvoltage by actively clamping the overvoltage across the power stage and the load. This is achieved by controlling the clamp voltage  $V_{DS(CL)}$  depending on the junction temperature  $T_J$  and the load current  $I_L$  (see [Figure 20](#) for details).

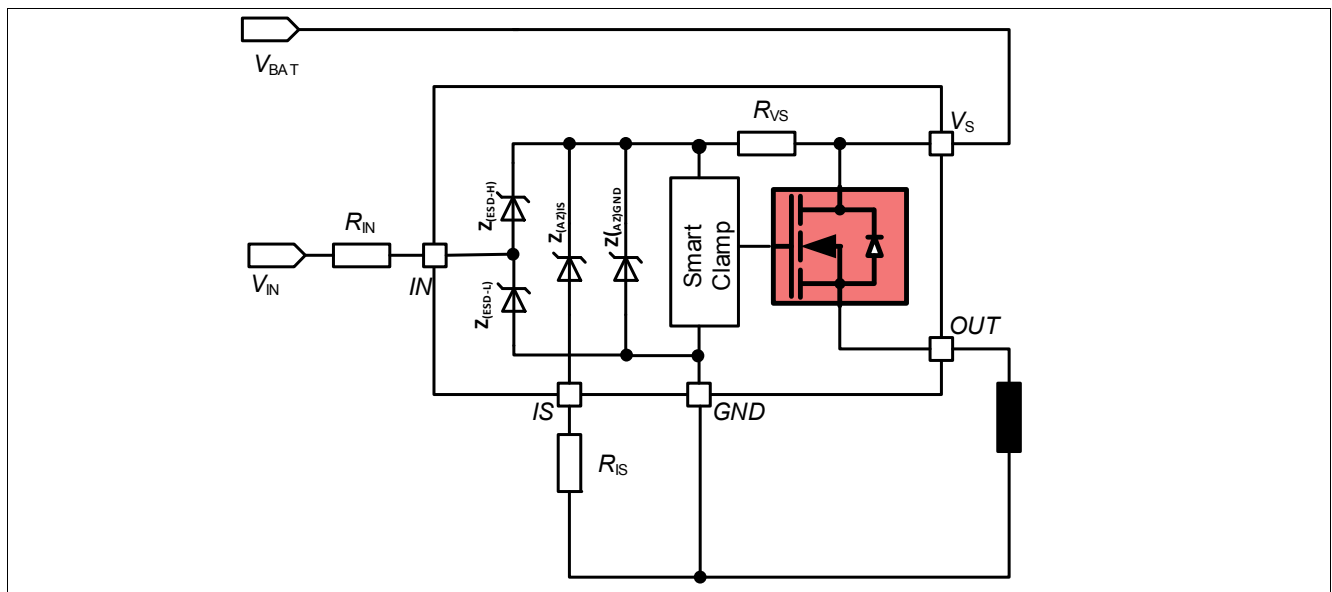

**Figure 20 Overvoltage Protection with External Components**

**5.3.5 Reverse Polarity Protection**

In case of reverse polarity, the intrinsic body diode of the power DMOS causes power dissipation. To limit the risk of overtemperature, the device provides Infineon® ReverSave™ functionality. The power in this intrinsic body diode is limited by turning the DMOS ON. The DMOS resistance is then equal to  $R_{DS(REV)}$ .

Additionally, the current into the logic has to be limited. The device includes a  $R_{VS}$  resistor which limits the current in the diodes. To avoid overcurrent in the  $R_{VS}$  resistor, it is nevertheless recommended to use a  $R_{IN}$  resistor. Please refer to maximum current described in [Chapter 4.1](#).

[Figure 21](#) shows a typical application.

$R_{IS}$  is used to limit the current in the sense transistor, which behaves as a diode.

The recommended typical value for  $R_{IN}$  is 4.7 kΩ and for  $R_{IS}$  1 kΩ.

**Functional Description**

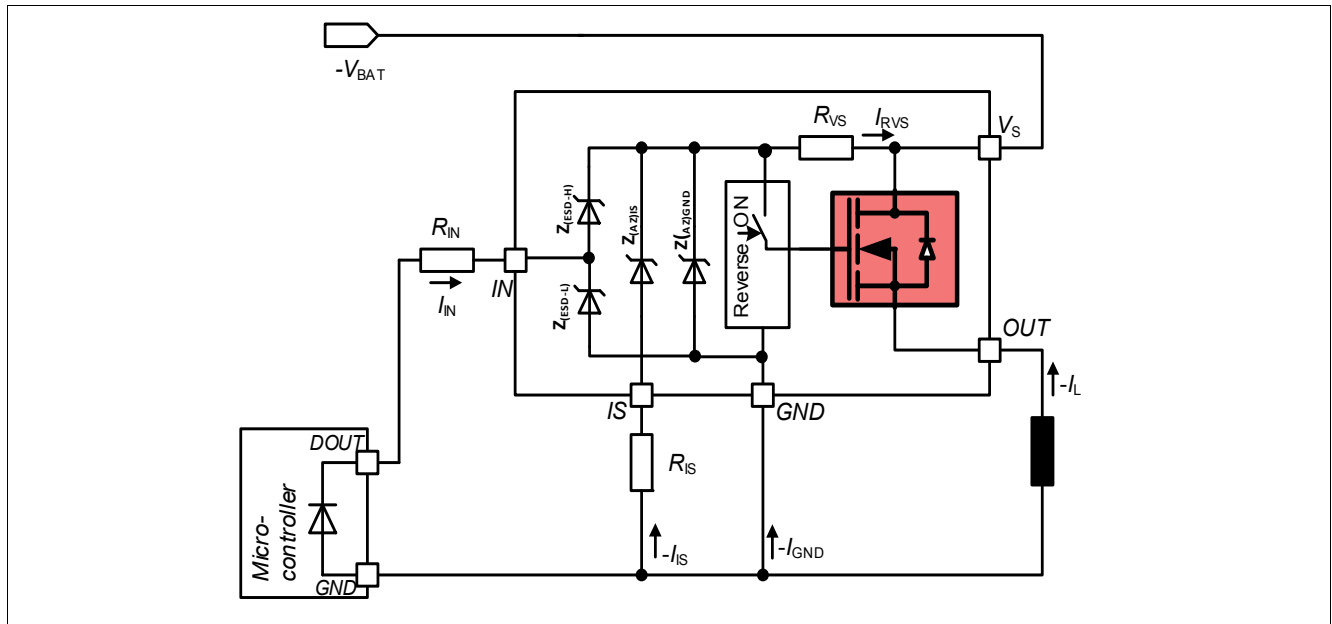

**Figure 21 Reverse Polarity Protection with External Components**

**5.3.6 Overload Protection**

In case of overload, high inrush current or short circuit to ground, the BTS50015-1TAD offers several protection mechanisms. Any protective switch OFF latches the output. To restart the device, it is necessary to set  $IN = LOW$  for  $t > t_{IN(RESETDELAY)}$ . This behavior is known as latch behavior. [Figure 25](#) gives a sketch of the situation.

**5.3.6.1 Activation of the Switch into Short Circuit (Short Circuit Type 1)**

When the switch is activated into short circuit, the current will raise until reaching the  $I_{CL(0)}$  value. After  $t_{OFF(TRIP)}$ , the device will turn OFF and latches until the IN pin is set to low for  $t > t_{IN(RESETDELAY)}$ . Under certain supply undervoltage shutdown conditions (for example  $V_S < V_{S(EXT,DYN)}$ ) the latched fault may be reset. For overload (short circuit or overtemperature), the maximum retry cycle ( $f_{fault}$ ) under fault condition must be considered.

**5.3.6.2 Short Circuit Appearance when the Device is already ON (Short Circuit Type 2)**

When the device is in ON state and a short circuit to ground appears at the output (SC2) with an overcurrent higher than  $I_{CL(0)}$  for a time longer than  $t_{OFF(TRIP)}$ , the device automatically turns OFF and latches until the IN pin is set to low for  $t > t_{IN(RESETDELAY)}$ . Under certain supply undervoltage shutdown conditions (for example  $V_S < V_{S(EXT,DYN)}$ ) the latched fault may be reset.

**5.3.6.3 Influence of the battery wire inductance**

The wire between the battery and the VS pin includes typically some parasitic inductance.

When the device switches off due to a short circuit event, the energy stored in the line inductance together with the capacitance (either the capacitor placed at VS pin or the internal capacitance between drain and source) could trigger an oscillatory behavior on the supply line at short circuit turn-off (see [Figure 22](#)), whose frequency depends on the inductance and capacitance values.

**Functional Description**

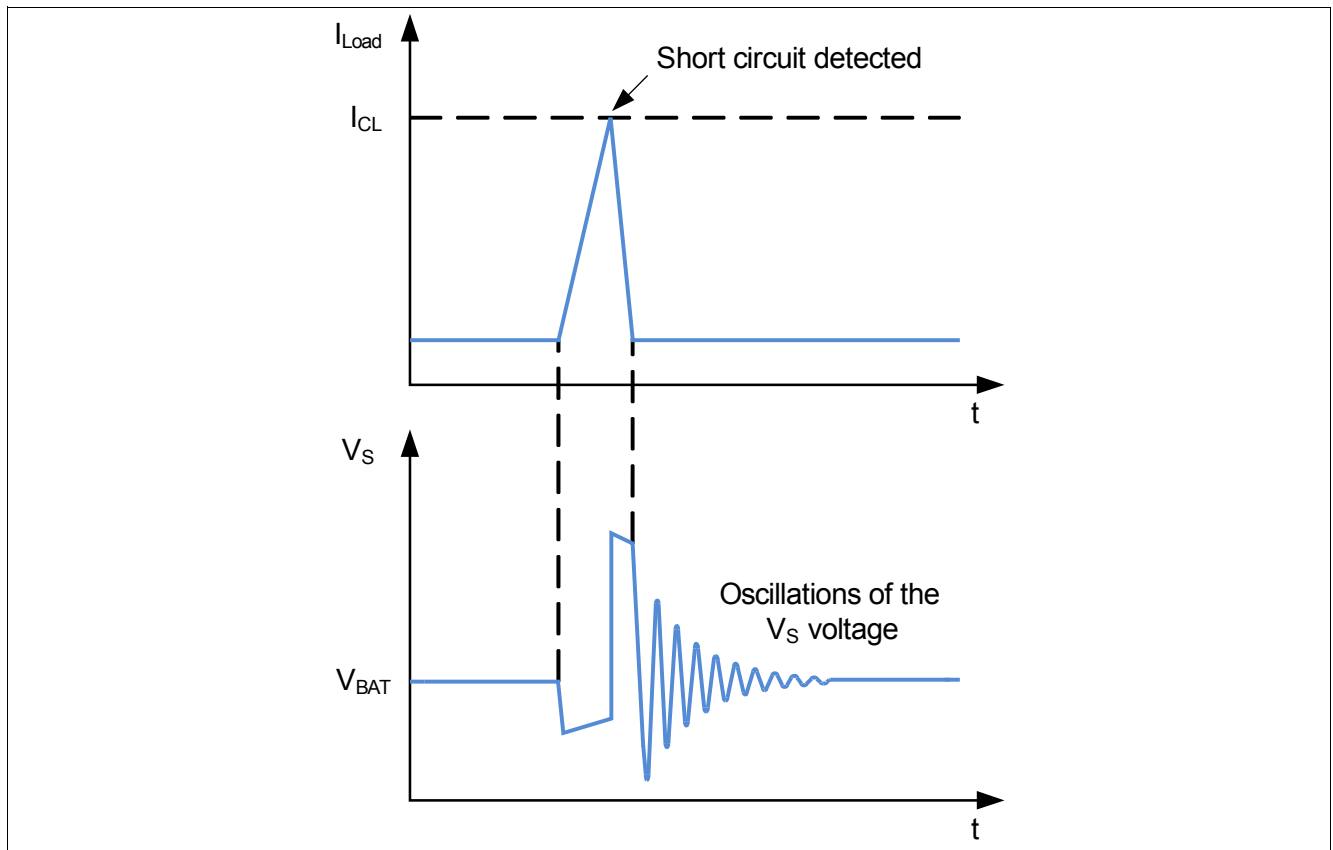

**Figure 22 Oscillations at VS pin**

The oscillations can pull the VS pin voltage to GND or even below. In some cases this behaviour may cause the device to reset the fault generated by the overcurrent event. As consequence the device may switch on again, as soon as the VS reaches an adequate value. The short circuit condition will be detected again and then the device will switch off. Short circuits and resets of the fault condition may repeatedly occur (see [Figure 23](#)).

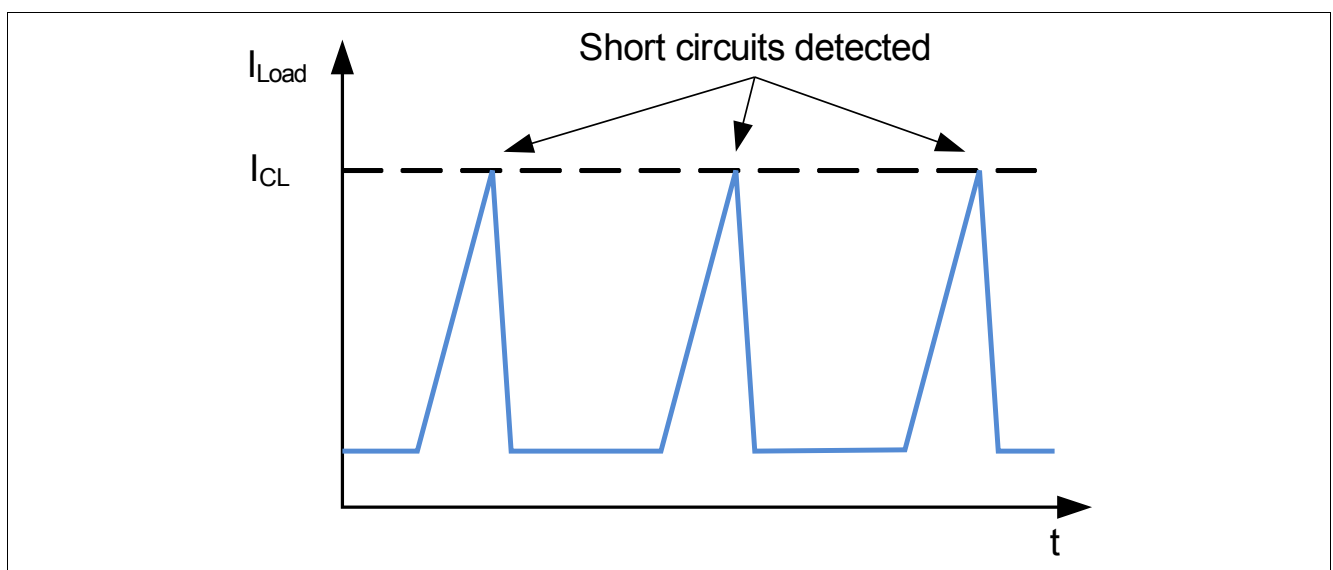
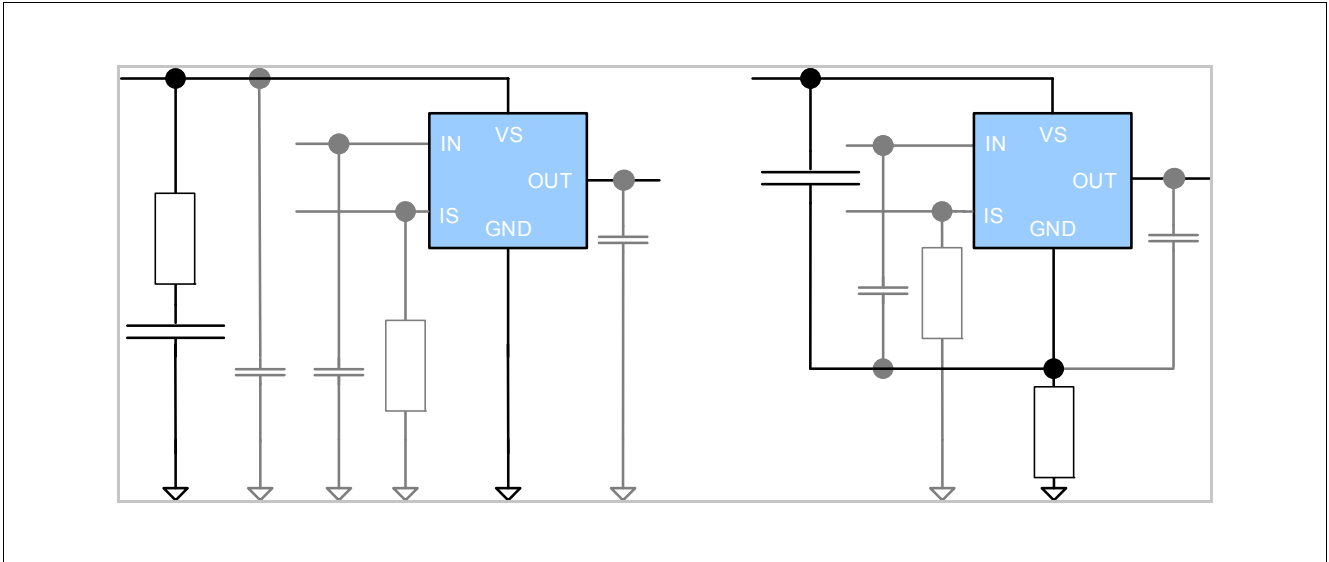

**Figure 23 Consecutive short circuit events**

## Functional Description

Potential solutions to dampen such oscillation and to achieve an effectively latching overcurrent protection is a RC snubber network, which needs to be connected between the VS pin and device or module GND.

**Figure 24** shows RC snubber circuits for each GND connection. For detailed information see **Chapter 7**.



**Figure 24 RC Snubber circuits: between VS pin and module GND; between VS pin and device GND**

The design of the most suitable RC snubber network is beyond the scope of this chapter. Nevertheless the recommendation given in **Chapter 7** contribute to effectively dampen the oscillation for typical line inductance and CVS.

### 5.3.7 Temperature Limitation in the Power DMOS

The BTS50015-1TAD incorporates an absolute ( $T_{J(TRIP)}$ ) temperature sensor. Activation of the sensor will cause an overheated channel to switch OFF to prevent destruction. The device restarts when the IN pin is set to low for  $t > t_{IN(RESETDELAY)}$  and the temperature has decreased below  $T_{J(TRIP)} - \Delta T_{J(TRIP)}$ . Under certain undervoltage shutdown conditions (for example below  $V_{S(EXT,DYN)}$ ) the latched fault might be reset.

**Functional Description**

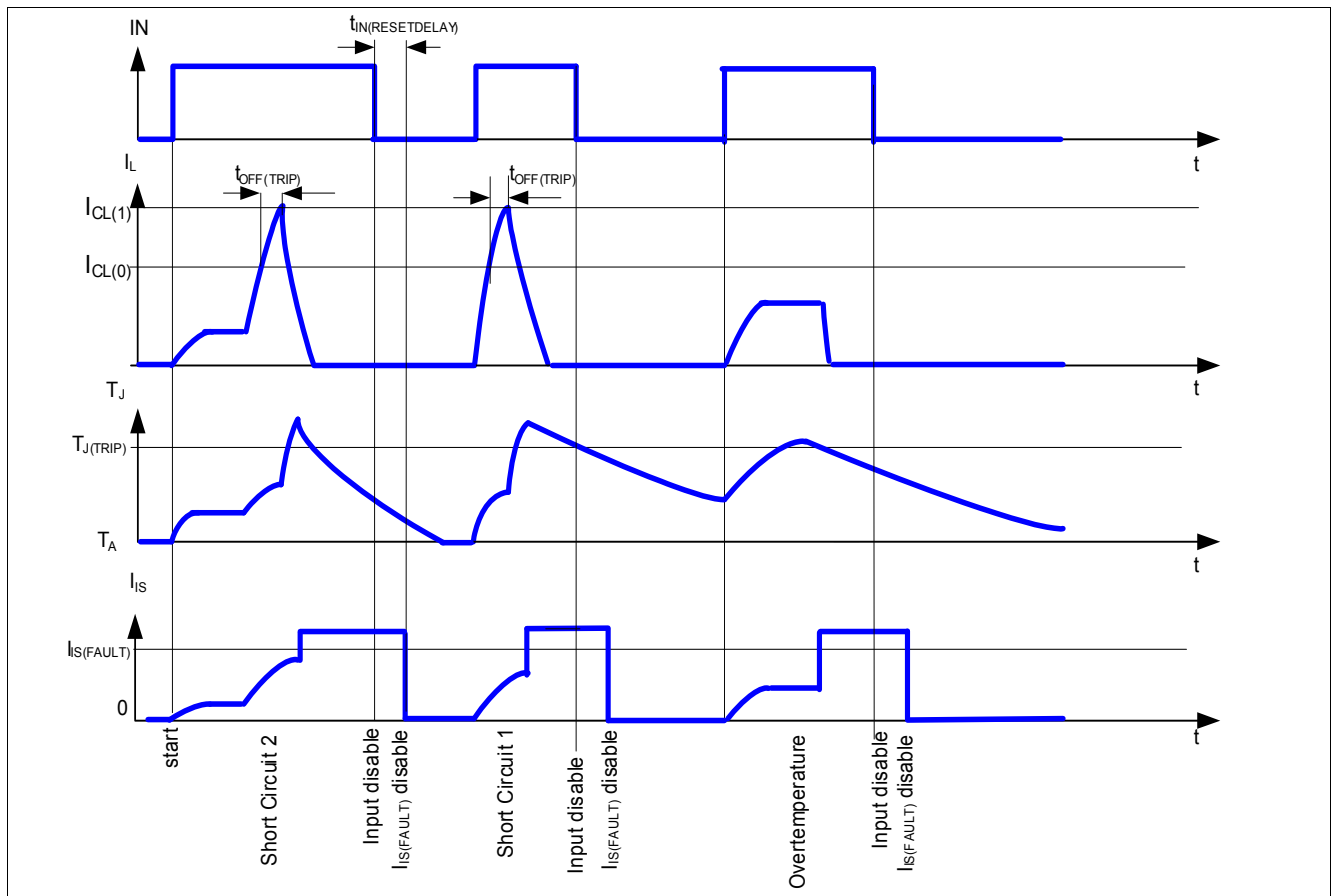

**Figure 25 Overload Protection**

The current sense exact signal timing can be found in the [Chapter 5.4](#). It is represented here only for device's behavior understanding.

In order to allow the device to detect overtemperature conditions and react effectively, it is recommended to limit the power dissipation below  $P_{TOT}$  (parameter 4.1.15).

## 5.4 Diagnostic Functions

For diagnosis purposes, the BTS50015-1TAD provides a combination of digital and analog signal at pin IS.

### 5.4.1 IS Pin

The BTS50015-1TAD provides an enhanced current sense signal called  $I_{IS}$  at pin IS. As long as no “hard” failure mode occurs (short circuit to GND / overcurrent / overtemperature) and the condition  $V_{IS} \leq V_{OUT} - 5\text{ V}$  is fulfilled, a proportional signal to the load current is provided. The complete IS pin and diagnostic mechanism is described in [Figure 26](#). The accuracy of the sense current depends on temperature and load current. In case of failure, a fixed  $I_{IS(FAULT)}$  is provided. In order to enable the fault current reporting, the condition  $V_S - V_{OUT} > 2\text{ V}$  must be fulfilled. In order to get the fault current in the specified range, the condition  $V_S - V_{IS} \geq 5\text{ V}$  must be fulfilled.

**Functional Description**

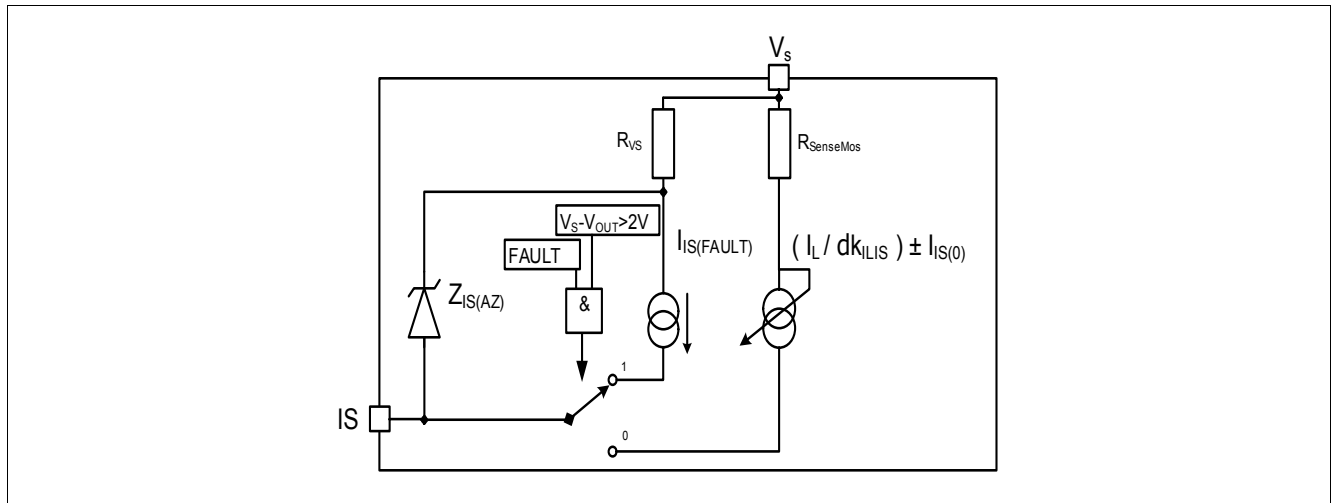

**Figure 26 Diagnostic Block Diagram**

**5.4.2 SENSE Signal in Different Operation Modes**

**Table 5 Sense Signal, Function of Operation Mode<sup>1)</sup>**

Operation mode	Input Level	Output Level $V_{OUT}$	Diagnostic Output ( $I_S$ ) <sup>2)</sup>
Normal operation	LOW (OFF)	~ GND	$I_{IS(OFF)}$
Short circuit to GND		GND	$I_{IS(OFF)}$
Overtemperature		~ GND	$I_{IS(OFF)}$
Short circuit to VS		$V_S$	$I_{IS(OFF)}$
Open Load		Z	$I_{IS(OFF)}$
Inverse current		$> V_S$	$I_{IS(OFF)}$
Normal operation		HIGH (ON)	~ $V_S$
Overcurrent condition	$< V_S$		$I_{IS} = (I_L / dk_{ILIS}) \pm I_{IS0}$ or $I_{IS(FAULT)}$
Short circuit to GND	GND		$I_{IS(FAULT)}$
Overtemperature (after the event)	~ GND		$I_{IS(FAULT)}$
Short circuit to VS	$V_S$		$I_{IS} < I_L / dk_{ILIS} \pm I_{IS0}$
Open Load	$V_S$		$I_{IS0}$
Inverse current	$> V_S$		$< I_{IS0}$

1) Z = High Impedance

2) See [Chapter 5.4.3](#) for Current Sense Range and Improved Current Sense Accuracy.

**5.4.3 SENSE Signal in the Nominal Current Range**

[Figure 27](#) and [Figure 28](#) show the current sense as function of the load current in the power DMOS. Usually, a pull-down resistor  $R_{IS}$  is connected to the current sense pin IS. A typical value is 1 kΩ. The dotted curve represents the typical sense current, assuming a typical  $dk_{ILIS}$  factor value. The range between the two solid curves shows the sense accuracy range that the device is able to provide, at a defined current.

$$I_{IS} = \frac{I_L}{dk_{ILIS}} + I_{IS0} \text{ with } (I_{IS} \geq 0) \tag{5.3}$$

**Functional Description**

where the definition of  $dk_{ILIS}$  is:

$$dk_{ILIS} = \frac{I_{L4} - I_{L1}}{I_{IS4} - I_{IS1}} \tag{5.4}$$

and the definition of  $I_{IS0}$  is:

$$I_{IS0} = I_{IS1} - \frac{I_{L1}}{dk_{ILIS}} \tag{5.5}$$

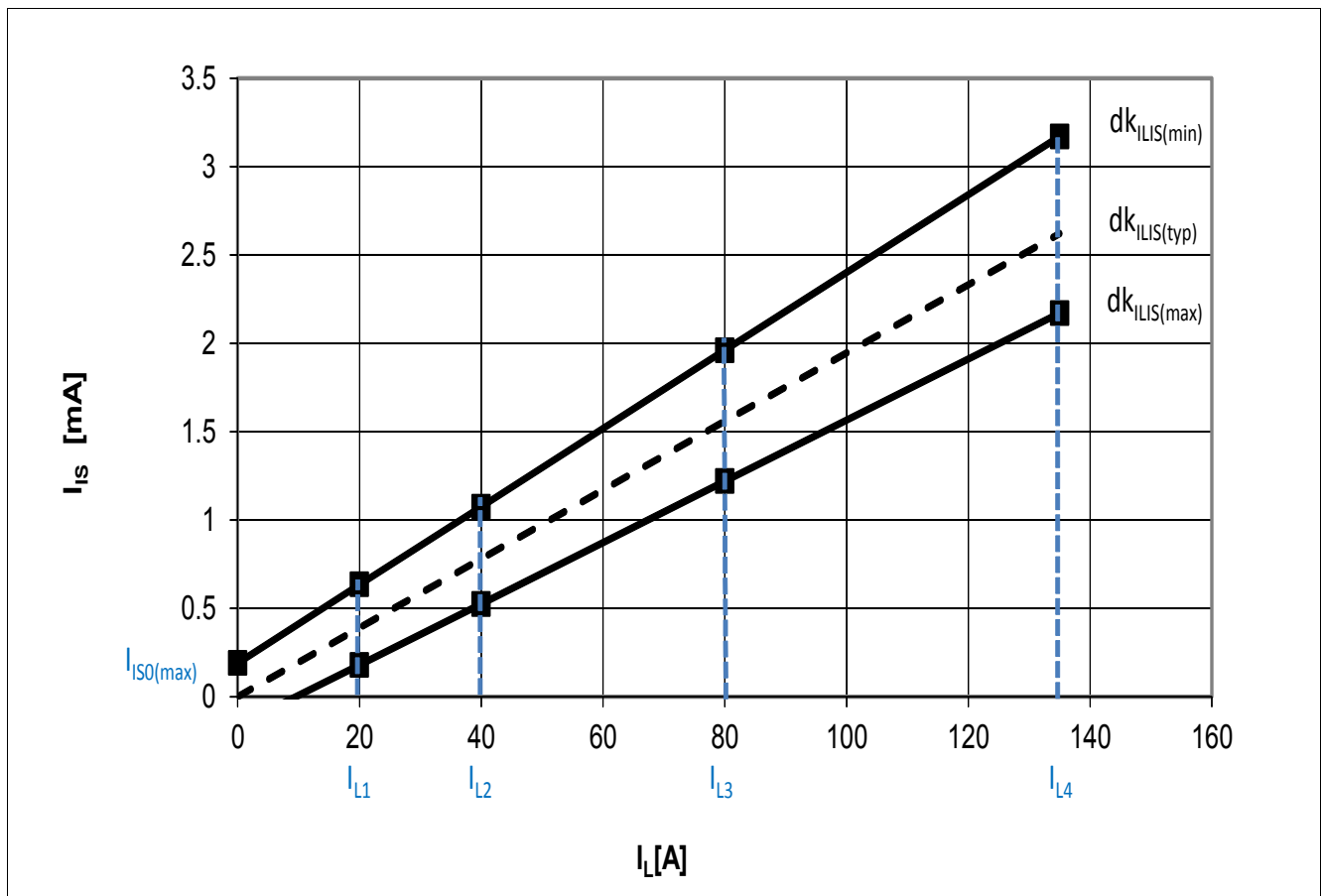

**Figure 27** Current Sense for Nominal and Overload Condition

**5.4.3.1 SENSE Signal Variation and Calibration**

In some applications, an enhanced accuracy is required around the device nominal current range  $I_{L(NOM)}$ . To achieve this accuracy requirement, a calibration on the application is possible. After two point calibration, the BTS50015-1TAD will have a limited  $I_{IS}$  value spread at different load currents and temperature conditions. The  $I_{IS}$  variation can be described with the parameters  $\Delta(dk_{ILIS(cal)})$  and the  $\Delta I_{ISO(cal)}$ . The blue solid line in **Figure 28** is the current sense ratio after the two point calibration at a given temperature. The slope of this line is defined as follows:

$$\frac{1}{dk_{ILIS(cal)}} = \frac{I_{IS(cal)2} - I_{IS(cal)1}}{I_{L(cal)2} - I_{L(cal)1}} \tag{5.6}$$

**Functional Description**

The offset is defined as follows:

$$I_{IS0(cal)} = I_{IS(cal)1} - \frac{I_{L(cal)1}}{dk_{ILIS(cal)}} = I_{IS(cal)2} - \frac{I_{L(cal)2}}{dk_{ILIS(cal)}} \quad (5.7)$$

The bluish area in **Figure 28** is the range where the current sense ratio can vary across temperature and load current after performing the calibration. The accuracy of the load current sensing is improved and, given a sense current value  $I_{IS}$  (measured in the application), the load current can be calculated as follow, using the absolute value for  $\Delta(dk_{ILIS(cal)})$  instead of % values:

$$I_L = dk_{ILIS(cal)} \times (1 + \Delta(dk_{ILIS(cal)})) \times (I_{IS} - I_{IS0(cal)} - \Delta I_{IS0(cal)}) \quad (5.8)$$

where  $dk_{ILIS(cal)}$  is the current sense ratio measured after two-points calibration (defined in **Equation (5.6)**),  $I_{IS0(cal)}$  is the current sense offset (calculated after two points calibration, see **Equation (5.7)**), and  $\Delta I_{IS0(cal)}$  is the additional variation of the individual offset over life time and temperature. For a calibration at 25°C  $\Delta I_{IS0(cal)}$  varies over temperature and life time for all positive  $\Delta I_{IS0(cal)}$  within the differences of the temperature dependent Max. limits. All negative  $\Delta I_{IS0(cal)}$  vary within the differences of the temperature dependent Min. limits.

For positive  $I_{IS0(cal)}$  values ( $I_{IS0(cal)} > 0$ ):

$$\text{Max } I_{IS0} (@T_J = 150^\circ\text{C}) - \text{Max } I_{IS0} (@T_J = 25^\circ\text{C}) \leq \Delta I_{IS0(cal)} \leq \text{Max } I_{IS0} (@T_J = -40^\circ\text{C}) - \text{Max } I_{IS0} (@T_J = 25^\circ\text{C}) \quad (5.9)$$

For negative  $I_{IS0(cal)}$  values ( $I_{IS0(cal)} < 0$ ):

$$\text{Min } I_{IS0} (@T_J = 150^\circ\text{C}) - \text{Min } I_{IS0} (@T_J = 25^\circ\text{C}) \geq \Delta I_{IS0(cal)} \geq \text{Min } I_{IS0} (@T_J = -40^\circ\text{C}) - \text{Min } I_{IS0} (@T_J = 25^\circ\text{C}) \quad (5.10)$$

**Equation (5.8)** actually provides four solutions for load current, considering that  $\Delta(dk_{ILIS(cal)})$  and  $\Delta I_{IS0(cal)}$  can be both positive and negative. The load current  $I_L$  for any sense current  $I_{IS}$  will spread between a minimum  $I_L$  value resulting from the combination of lowest  $\Delta(dk_{ILIS(cal)})$  value and highest  $\Delta I_{IS0(cal)}$  and a maximum  $I_L$  value resulting from the combination of highest  $\Delta(dk_{ILIS(cal)})$  value and lowest  $\Delta I_{IS0(cal)}$ .



Functional Description

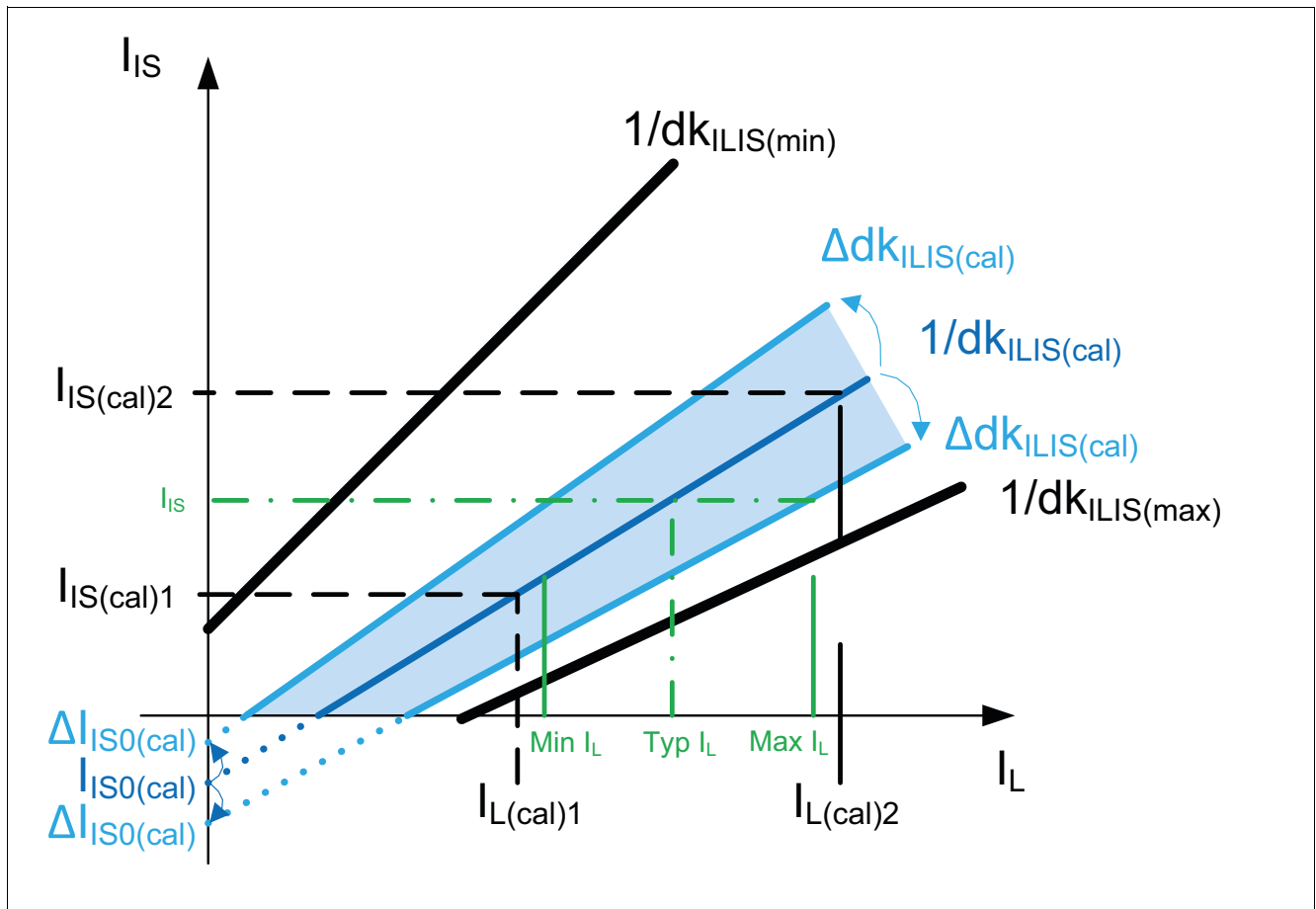
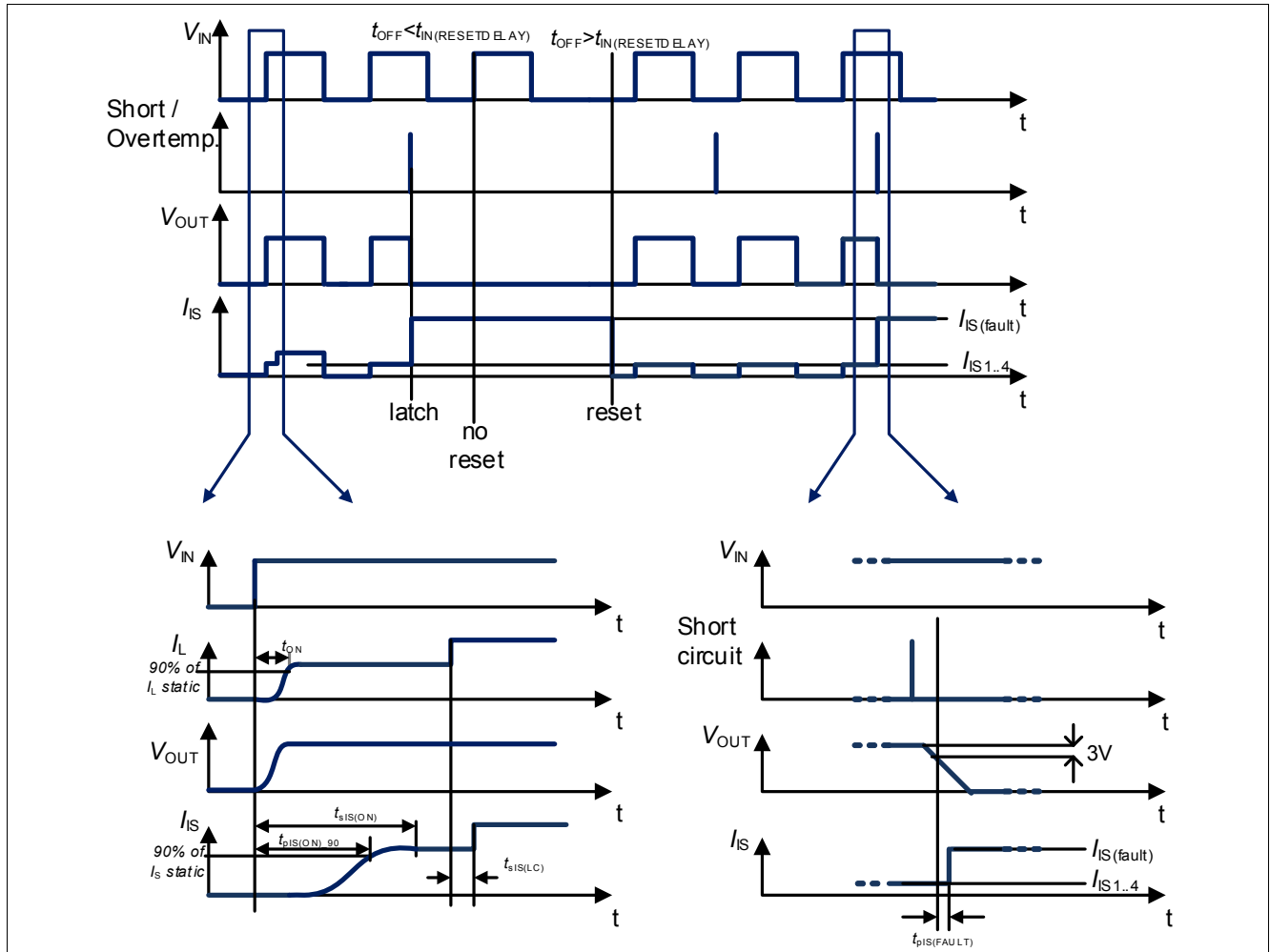

Figure 28 Improved Current Sense Accuracy after 2-Point Calibration

**Functional Description**

**5.4.3.2 SENSE Signal Timing**

Figure 29 shows the timing during settling and disabling of the sense.



**Figure 29 Fault Acknowledgement**

**5.4.3.3 SENSE Signal in Case of Short Circuit to  $V_S$**

In case of a short circuit between OUT and  $V_S$ , a major part of the load current will flow through the short circuit. As a result, a lower current compared to the nominal operation will flow through the DMOS of the BTS50015-1TAD, which can be recognized at the current sense signal.

**5.4.3.4 SENSE Signal in Case of Over Load**

An over load condition is defined by a current flowing out of the DMOS reaching the current over load  $I_{CL}$  or the junction temperature reaches the thermal shutdown temperature  $T_{J(TRIP)}$ . Please refer to [Chapter 5.3.6](#) for details. In that case, the SENSE signal will be in the range of  $I_{IS(FAULT)}$  when the IN pin stays HIGH.

This is a device with latch functionality. The state of the device will remain and the sense signal will remain on  $I_{IS(FAULT)}$  until a reset signal comes from the IN pin. For example, when a thermal shutdown occurs, even when the over temperature condition has disappeared, the DMOS can only be reactivated when a reset signal is sent to the IN pin.

## 6 Electrical Characteristics BTS50015-1TAD

### 6.1 Electrical Characteristics Table

**Table 6 Electrical Characteristics: BTS50015-1TAD**

$V_S = 8\text{ V to }18\text{ V}$ ,  $T_J = -40^\circ\text{C to }+150^\circ\text{C}$  (unless otherwise specified)

For a given temperature or voltage range, typical values are specified at  $V_S = 13.5\text{ V}$ ,  $T_J = 25^\circ\text{C}$

Parameter	Symbol	Values			Unit	Note or Test Condition	Number
		Min.	Typ.	Max.			
<b>Operating and Standby Currents</b>							
Operating Current (Channel Active)	$I_{\text{GND(ACTIVE)}}$	–	1.2	3	mA	$V_{\text{IN}} \geq 2.2\text{ V}$	P_6.1.1
Standby Current for Whole Device with Load	$I_{\text{VS(OFF)}}$	–	7	18	$\mu\text{A}$	<sup>1)</sup> $V_S = 18\text{ V}$ $V_{\text{OUT}} = 0\text{ V}$ $V_{\text{IN}} \leq 0.8\text{ V}$ $T_J \leq 85^\circ\text{C}$ See <a href="#">Page 41</a>	P_6.1.2
Maximum Standby Current for Whole Device with Load	$I_{\text{VS(OFF)}}$	–	25	120	$\mu\text{A}$	$V_S = 18\text{ V}$ $V_{\text{OUT}} = 0\text{ V}$ $V_{\text{IN}} \leq 0.8\text{ V}$ $T_J \leq 150^\circ\text{C}$ See <a href="#">Page 41</a>	P_6.1.3
<b>Power Stage</b>							
ON-State Resistance in Forward Condition	$R_{\text{DS(ON)}}$	–	2.1	3	m $\Omega$	$I_L = 135\text{ A}$ $V_{\text{IN}} \geq 2.2\text{ V}$ $T_J = 150^\circ\text{C}$ See <a href="#">Page 42</a>	P_6.1.4
ON-State Resistance in Forward Condition, Low Battery Voltage	$R_{\text{DS(ON)}}$	–	3.2	5	m $\Omega$	$I_L = 20\text{ A}$ $V_{\text{IN}} \geq 2.2\text{ V}$ $V_S = 5.5\text{ V}$ $T_J = 150^\circ\text{C}$ See <a href="#">Page 42</a>	P_6.1.5
ON-State Resistance in Forward Condition	$R_{\text{DS(ON)}}$	–	1.5	–	m $\Omega$	<sup>1)</sup> $I_L = 135\text{ A}$ $V_{\text{IN}} \geq 2.2\text{ V}$ $T_J = 25^\circ\text{C}$ See <a href="#">Page 42</a>	P_6.1.6
ON-State Resistance in Inverse Condition	$R_{\text{DS(INV)}}$	–	2.1	3.1	m $\Omega$	$I_L = -135\text{ A}$ $V_{\text{IN}} \geq 2.2\text{ V}$ $T_J = 150^\circ\text{C}$ See <a href="#">Figure 11</a>	P_6.1.7
ON-State Resistance in Inverse Condition	$R_{\text{DS(INV)}}$	–	1.5	–	m $\Omega$	<sup>1)</sup> $I_L = -135\text{ A}$ $V_{\text{IN}} \geq 2.2\text{ V}$ $T_J = 25^\circ\text{C}$ See <a href="#">Figure 11</a>	P_6.1.8

**Electrical Characteristics BTS50015-1TAD**

**Table 6 Electrical Characteristics: BTS50015-1TAD (cont'd)**

$V_S = 8\text{ V to }18\text{ V}$ ,  $T_J = -40^\circ\text{C to }+150^\circ\text{C}$  (unless otherwise specified)

For a given temperature or voltage range, typical values are specified at  $V_S = 13.5\text{ V}$ ,  $T_J = 25^\circ\text{C}$

Parameter	Symbol	Values			Unit	Note or Test Condition	Number
		Min.	Typ.	Max.			
Nominal Load Current	$I_{L(NOM)}$	33	39	–	A	$T_A = 85^\circ\text{C}^2)$ $T_J \leq 150^\circ\text{C}$	P_6.1.9
Drain to Source Smart Clamp Voltage $V_{DS(CL)} = V_S - V_{OUT}$	$V_{DS(CL)}$	28	–	46	V	$I_{DS} = 50\text{ mA}$ See <a href="#">Page 44</a>	P_6.1.11
Output Leakage Current	$I_{L(OFF)}$	–	5	15	$\mu\text{A}$	<sup>1)</sup> $V_{IN} \leq 0.8\text{ V}$ $V_{OUT} = 0\text{ V}$ $T_J \leq 85^\circ\text{C}$	P_6.1.13
Output Leakage Current	$I_{L(OFF)}$	–	20	100	$\mu\text{A}$	$V_{IN} \leq 0.8\text{ V}$ $V_{OUT} = 0\text{ V}$ $T_J = 150^\circ\text{C}$	P_6.1.14
Turn ON Slew Rate $V_{OUT} = 25\% \text{ to } 50\% V_S$	$dV_{ON}/dt$	0.05	0.23	0.5	$\text{V}/\mu\text{s}$	$R_L = 0.5\ \Omega$ $V_S = 13.5\text{ V}$	P_6.1.15
Turn OFF Slew Rate $V_{OUT} = 50\% \text{ to } 25\% V_S$	$-dV_{OFF}/dt$	0.05	0.25	0.55	$\text{V}/\mu\text{s}$	See <a href="#">Figure 8</a> See <a href="#">Page 42</a> See <a href="#">Page 43</a>	P_6.1.16
Turn ON Time to $V_{OUT} = 90\% V_S$	$t_{ON}$	–	220	700	$\mu\text{s}$		P_6.1.17
Turn OFF Time to $V_{OUT} = 10\% V_S$	$t_{OFF}$	–	300	700	$\mu\text{s}$		P_6.1.18
Turn ON Time to $V_{OUT} = 10\% V_S$	$t_{ON(Delay)}$	–	80	150	$\mu\text{s}$		P_6.1.19
Turn OFF Time to $V_{OUT} = 90\% V_S$	$t_{OFF(Delay)}$	–	230	500	$\mu\text{s}$		P_6.1.20
Switch ON Energy	$E_{ON}$	–	7	–	mJ	<sup>1)</sup> $R_L = 0.5\ \Omega$ $V_S = 13.5\text{ V}$ See <a href="#">Page 43</a>	P_6.1.21
Switch OFF Energy	$E_{OFF}$	–	5	–	mJ	<sup>1)</sup> $R_L = 0.5\ \Omega$ $V_S = 13.5\text{ V}$ See <a href="#">Page 43</a>	P_6.1.22

**Electrical Characteristics BTS50015-1TAD**

**Table 6 Electrical Characteristics: BTS50015-1TAD (cont'd)**

$V_S = 8\text{ V to }18\text{ V}$ ,  $T_J = -40^\circ\text{C to }+150^\circ\text{C}$  (unless otherwise specified)

For a given temperature or voltage range, typical values are specified at  $V_S = 13.5\text{ V}$ ,  $T_J = 25^\circ\text{C}$

Parameter	Symbol	Values			Unit	Note or Test Condition	Number
		Min.	Typ.	Max.			
<b>Input Pin</b>							
LOW Level Input Voltage	$V_{IN(L)}$	–	–	0.8	V	See <a href="#">Page 44</a>	P_6.1.23
HIGH Level Input Voltage	$V_{IN(H)}$	2.2	–	–	V	See <a href="#">Page 44</a>	P_6.1.24
Input Voltage Hysteresis	$V_{IN(HYS)}$	–	200	–	mV	<sup>1)</sup>	P_6.1.25
LOW Level Input Current	$I_{IN(L)}$	8	–	–	$\mu\text{A}$	$V_{IN} = 0.8\text{ V}$	P_6.1.26
HIGH Level Input Current	$I_{IN(H)}$	–	–	80	$\mu\text{A}$	$V_{IN} \geq 2.2\text{ V}$	P_6.1.27

**Protection: Loss of Ground**

Output Leakage Current while Module GND Disconnected	$I_{OUT(GND\_M)}$	0	20	100	$\mu\text{A}$	<sup>1)3)</sup> $V_S = 18\text{ V}$ $V_{OUT} = 0\text{ V}$ IS & IN pins open GND pin open $T_J = 150^\circ\text{C}$ See <a href="#">Figure 16</a>	P_6.1.28
Output Leakage Current while Device GND Disconnected	$I_{OUT(GND)}$	0	20	100	$\mu\text{A}$	$V_S = 18\text{ V}$ GND pin open $V_{IN} \geq 2.2\text{ V}$ 1 k $\Omega$ pull down from IS to GND 4.7 k $\Omega$ to IN pin $T_J = 150^\circ\text{C}$ See <a href="#">Figure 16</a> See <a href="#">Page 45</a>	P_6.1.29

**Protection: Reverse Polarity**

ON-State Resistance in Reverse Polarity	$R_{DS(REV)}$	–	–	3.2	m $\Omega$	$V_S = 0\text{ V}$ $V_{GND} = V_{IN} = 16\text{ V}$ $I_L = -20\text{ A}$ $T_J = 150^\circ\text{C}$ See <a href="#">Figure 21</a>	P_6.1.30
ON-State Resistance in Reverse Polarity	$R_{DS(REV)}$	–	1.5	–	m $\Omega$	<sup>1)</sup> $V_S = 0\text{ V}$ $V_{GND} = V_{IN} = 16\text{ V}$ $I_L = -20\text{ A}$ $T_J = 25^\circ\text{C}$ See <a href="#">Page 45</a>	P_6.1.31
Integrated Resistor	$R_{VS}$	–	60	90	$\Omega$	$T_J = 25^\circ\text{C}$	P_6.1.32

**Electrical Characteristics BTS50015-1TAD**

**Table 6 Electrical Characteristics: BTS50015-1TAD (cont'd)**

$V_S = 8\text{ V to }18\text{ V}$ ,  $T_J = -40^\circ\text{C to }+150^\circ\text{C}$  (unless otherwise specified)

For a given temperature or voltage range, typical values are specified at  $V_S = 13.5\text{ V}$ ,  $T_J = 25^\circ\text{C}$

Parameter	Symbol	Values			Unit	Note or Test Condition	Number
		Min.	Typ.	Max.			
<b>Protection: Overvoltage</b>							
Overvoltage Protection $V_S$ to GND Pin	$V_{S(AZ)\_GND}$	64	70	80	V	See <a href="#">Figure 20</a> See <a href="#">Page 44</a>	P_6.1.33
Overvoltage Protection $V_S$ to IS Pin	$V_{S(AZ)\_IS}$	64	70	80	V	GND and IN pin open See <a href="#">Figure 20</a> See <a href="#">Page 44</a>	P_6.1.34
<b>Protection: Overload</b>							
Current Trip Detection Level	$I_{CL(0)}$	135	175	–	A	$V_S = 13.5\text{ V}$ , static $T_J = 150^\circ\text{C}$ See <a href="#">Figure 25</a>	P_6.1.35
	$I_{CL(0)}$	145	185	–	A	$V_S = 13.5\text{ V}$ , static $T_J = -40 \dots 25^\circ\text{C}$ See <a href="#">Figure 25</a>	
Current Trip Maximum Level	$I_{CL(1)}$	–	190	250	A	<sup>1)</sup> $V_S = 13.5\text{ V}$ $dI_L/dt = 1\text{ A}/\mu\text{s}$ See <a href="#">Page 45</a>	
Overload Shutdown Delay Time	$t_{OFF(TRIP)}$	–	12	–	$\mu\text{s}$	<sup>1)</sup>	P_6.1.36
Thermal Shutdown Temperature	$T_{J(TRIP)}$	150	170 <sup>1)</sup>	200 <sup>1)</sup>	$^\circ\text{C}$	See <a href="#">Figure 25</a>	P_6.1.37
Thermal Shutdown Hysteresis	$\Delta T_{J(TRIP)}$	–	10	–	K	<sup>1)</sup>	P_6.1.38
<b>Diagnostic Function: Sense Pin</b>							
Sense Signal Current in Fault Condition	$I_{IS(FAULT)}$	3.5	6	8	mA	<sup>1)</sup> $V_{IN} = 4.5\text{ V}$ $V_S - V_{IS} \geq 5\text{ V}$	P_6.1.40
Sense Signal Saturation Current	$I_{IS(LIM)}$	3.5	6	8	mA	<sup>1)</sup> $V_{IN} = 4.5\text{ V}$ $V_S - V_{IS} \geq 5\text{ V}$	P_6.1.57

**Electrical Characteristics BTS50015-1TAD**

**Table 6 Electrical Characteristics: BTS50015-1TAD (cont'd)**

$V_S = 8\text{ V to }18\text{ V}$ ,  $T_J = -40^\circ\text{C to }+150^\circ\text{C}$  (unless otherwise specified)

For a given temperature or voltage range, typical values are specified at  $V_S = 13.5\text{ V}$ ,  $T_J = 25^\circ\text{C}$

Parameter	Symbol	Values			Unit	Note or Test Condition	Number
		Min.	Typ.	Max.			
<b>Diagnostic Function: Current Sense Ratio Signal in the Nominal Area, Stable Current Load Condition</b>							
Current Sense Differential Ratio	$dk_{ILIS}$	45300	51500	57700	–	$I_{L4} = 135\text{ A}$ $I_{L1} = 20\text{ A}$ See <a href="#">Equation (5.4)</a>	P_6.1.41
Calculated Sense Offset Current $I_L = I_{L0} = 0\text{ A}$	$I_{IS0}$	-165	15	190	$\mu\text{A}$	<sup>4)</sup> $V_{IN} \geq 2.2\text{ V}$ $V_S - V_{IS} \geq 5\text{ V}$ $T_J = -40^\circ\text{C}$ See <a href="#">Figure 27</a>	P_6.1.42
	$I_{IS0}$	-115	5	125	$\mu\text{A}$	<sup>1)4)</sup> $V_{IN} \geq 2.2\text{ V}$ $V_S - V_{IS} \geq 5\text{ V}$ $T_J = 25^\circ\text{C}$ See <a href="#">Figure 27</a>	
	$I_{IS0}$	-65	-5	60	$\mu\text{A}$	<sup>4)</sup> $V_{IN} \geq 2.2\text{ V}$ $V_S - V_{IS} \geq 5\text{ V}$ $T_J = 150^\circ\text{C}$ See <a href="#">Figure 27</a>	
Sense Current $I_L = I_{L1} = 20\text{ A}$	$I_{IS1}$	180	390	635	$\mu\text{A}$	<sup>1)</sup> $V_{IN} \geq 2.2\text{ V}$ $V_S - V_{IS} \geq 5\text{ V}$ See <a href="#">Figure 27</a>	P_6.1.43
Sense Current $I_L = I_{L2} = 40\text{ A}$	$I_{IS2}$	525	780	1075	$\mu\text{A}$	See <a href="#">Figure 27</a>	P_6.1.44
Sense Current $I_L = I_{L3} = 80\text{ A}$	$I_{IS3}$	1.22	1.56	1.96	$\text{mA}$	<sup>1)</sup> $V_{IN} \geq 2.2\text{ V}$ $V_S - V_{IS} \geq 5\text{ V}$ See <a href="#">Figure 27</a>	P_6.1.45
Sense Current $I_L = I_{L4} = 135\text{ A}$	$I_{IS4}$	2.17	2.62	3.17	$\text{mA}$	See <a href="#">Figure 27</a>	P_6.1.46
Current Sense Ratio Spread over Temperature and Repetitive Pulse Operation after 2-Points Calibration	$\Delta(dk_{ILIS(cal)})$	-5	0	5	%	<sup>1)</sup> See <a href="#">Figure 28</a>	P_6.1.47
<b>Diagnostic Function: Diagnostic Timing in Normal Condition</b>							
Current Sense Propagation Time until 90% of $I_{IS}$ Stable After Positive Input Slope on IN Pin	$t_{pIS(ON)_90}$	0	–	700	$\mu\text{s}$	$V_{IN} \geq 2.2\text{ V}$ $V_S = 13.5\text{ V}$ $R_L = 0.5\ \Omega$ See <a href="#">Figure 29</a>	P_6.1.48
Current Sense Settling Time to $I_{IS}$ Stable after Positive Input Slope on IN Pin	$t_{sIS(ON)}$	–	–	3000	$\mu\text{s}$	$V_{IN} \geq 2.2\text{ V}$ $V_S = 13.5\text{ V}$ $R_L = 0.5\ \Omega$ See <a href="#">Figure 29</a>	P_6.1.49
$I_{IS}$ Leakage Current when IN Disabled	$I_{IS(OFF)}$	0	0.05	1	$\mu\text{A}$	$V_{IN} \leq 0.8\text{ V}$ $R_{IS} = 1\text{ k}\Omega$	P_6.1.50

**Electrical Characteristics BTS50015-1TAD**

**Table 6 Electrical Characteristics: BTS50015-1TAD (cont'd)**

$V_S = 8\text{ V to }18\text{ V}$ ,  $T_J = -40^\circ\text{C to }+150^\circ\text{C}$  (unless otherwise specified)

For a given temperature or voltage range, typical values are specified at  $V_S = 13.5\text{ V}$ ,  $T_J = 25^\circ\text{C}$

Parameter	Symbol	Values			Unit	Note or Test Condition	Number
		Min.	Typ.	Max.			
Current Sense Settling Time after Load Change	$t_{\text{SIS(LC)}}$	–	50	–	$\mu\text{s}$	<sup>1)</sup> $V_{\text{IN}} \geq 2.2\text{ V}$ $dI_L/dt = 0.4\text{ A}/\mu\text{s}$	P_6.1.51

**Diagnostic Function: Diagnostic Timing in Overload Condition**

Current Sense Propagation Time for Short Circuit Detection	$t_{\text{pIS(FAULT)}}$	0	–	100	$\mu\text{s}$	<sup>1)</sup> $V_{\text{IN}} \geq 2.2\text{ V}$ from $V_{\text{OUT}} = V_S - 3\text{ V}$ to $I_{\text{IS(FAULT)_min}}$ See <a href="#">Figure 29</a>	P_6.1.52
Delay Time to Reset Fault Signal at IS Pin after Turning OFF $V_{\text{IN}}$	$t_{\text{IN(RESETDELAY)}}$	250	1000	1500	$\mu\text{s}$	<sup>1)</sup>	P_6.1.53

**Timing: Inverse Behavior**

Propagation Time From $V_{\text{OUT}} > V_S$ to Fault Disable	$t_{\text{p,INV,noFAULT}}$	–	4	–	$\mu\text{s}$	<sup>1)</sup> See <a href="#">Figure 12</a>	P_6.1.55
Propagation Time from $V_{\text{OUT}} < V_S$ to Fault Enable	$t_{\text{p,noINV,FAULT}}$	–	10	–	$\mu\text{s}$	<sup>1)</sup> See <a href="#">Figure 12</a>	P_6.1.56

1) Not subject to production test, specified by design.

2) Value is calculated from the parameters  $\text{typ. } R_{\text{thJA}(2\text{s}2\text{p})}$ , with 65 K temperature increase,  $\text{typ. and max. } R_{\text{DS(ON)}}$ .

3) All pins are disconnected except  $V_S$  and OUT.

4) Value is calculated from the parameters  $dk_{\text{ILIS}}$  and  $I_{\text{IS1}}$ .



**6.2 Typical Performance Characteristics**

**Standby Current for Whole Device with Load,**  
 $I_{VS(OFF)} = f(V_S, T_J)$

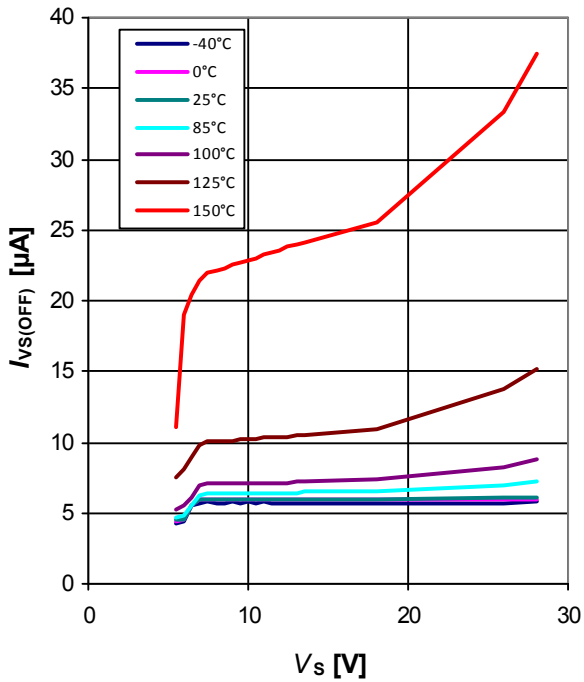

**Standby Current for Whole Device with Load,**  
 $I_{VS(OFF)} = f(T_J)$  at  $V_S = 13.5 V$

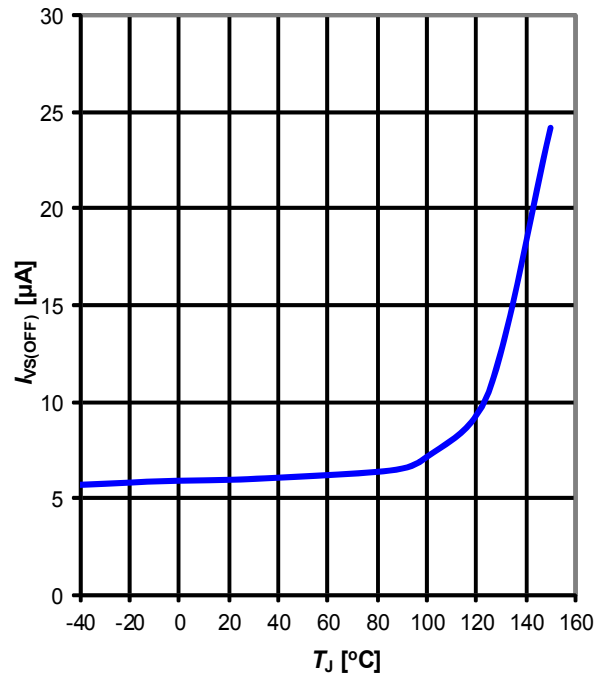

**GND Leakage Current**  
 $I_{GND(OFF)} = f(V_S, T_J)$

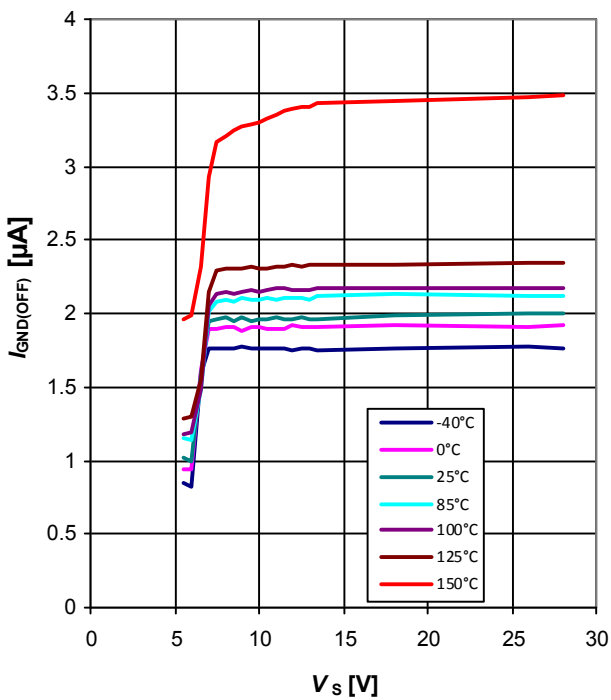

**GND Leakage Current**  
 $I_{GND(OFF)} = f(T_J)$  at  $V_S = 13.5 V$

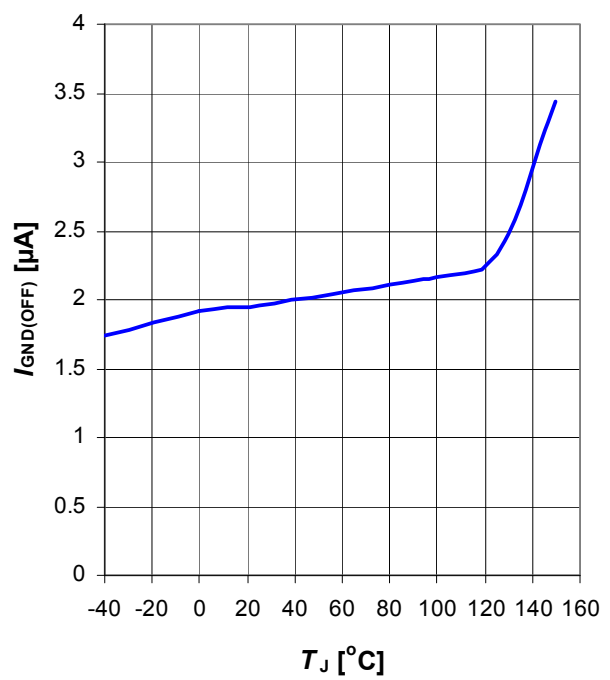

**Electrical Characteristics BTS50015-1TAD**

**ON State Resistance**

$R_{DS(ON)} = f(V_S, T_J), I_L = 20 \text{ A} \dots 135 \text{ A}$

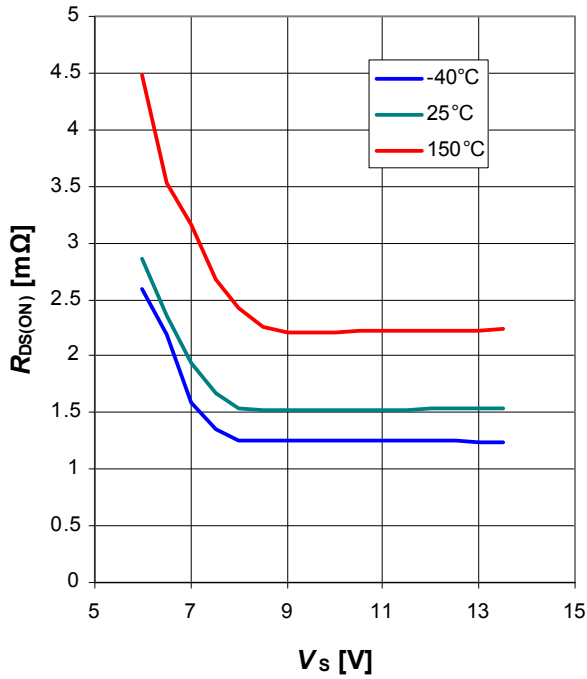

**ON State Resistance**

$R_{DS(ON)} = f(T_J), V_S = 13.5 \text{ V}, I_L = 20 \text{ A} \dots 135 \text{ A}$

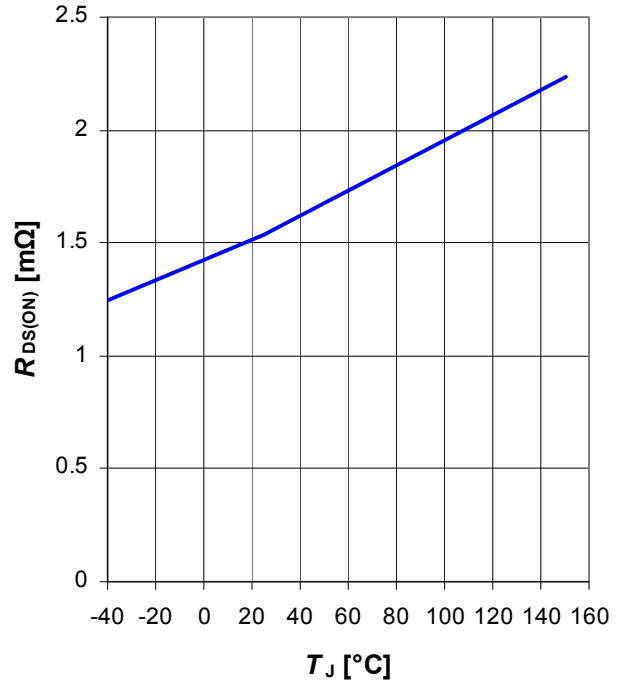

**Turn ON Time**

$t_{ON} = f(V_S, T_J), R_L = 0.5 \Omega$

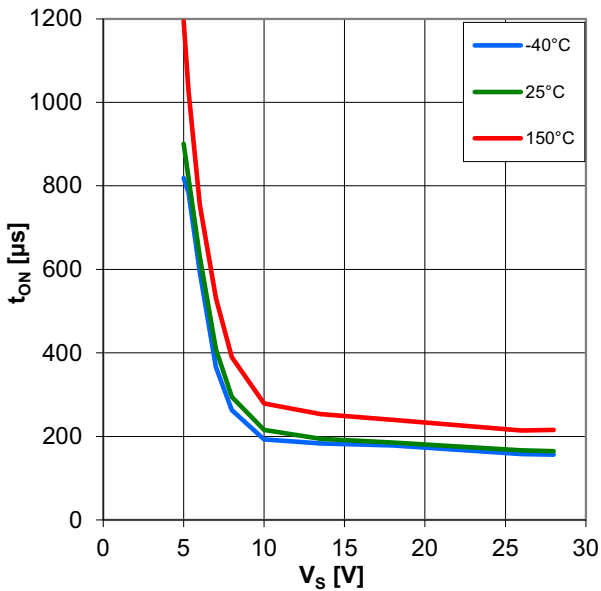

**Turn OFF Time**

$t_{OFF} = f(V_S, T_J), R_L = 0.5 \Omega$

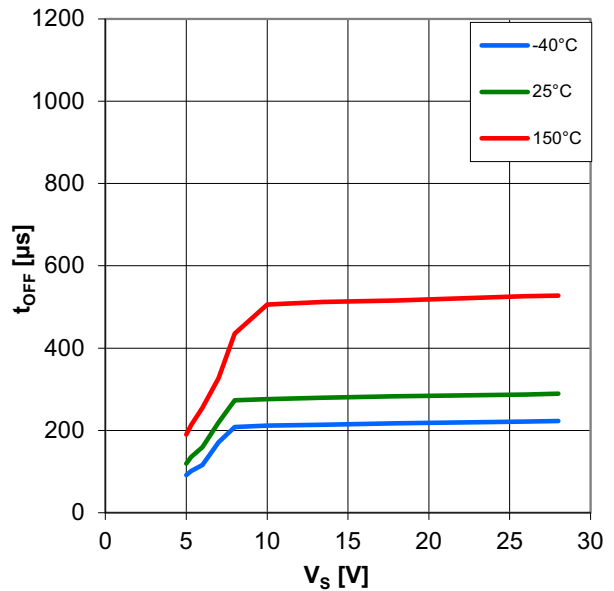

**Electrical Characteristics BTS50015-1TAD**

**Slew Rate at Turn ON**

$dV_{ON} / t = f(V_S, T_J), R_L = 0.5 \Omega$

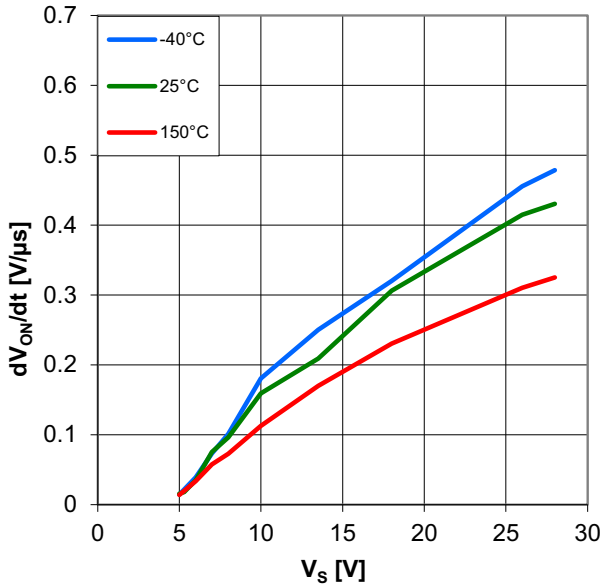

**Slew Rate at Turn OFF**

$dV_{OFF} / t = f(V_S, T_J), R_L = 0.5 \Omega$

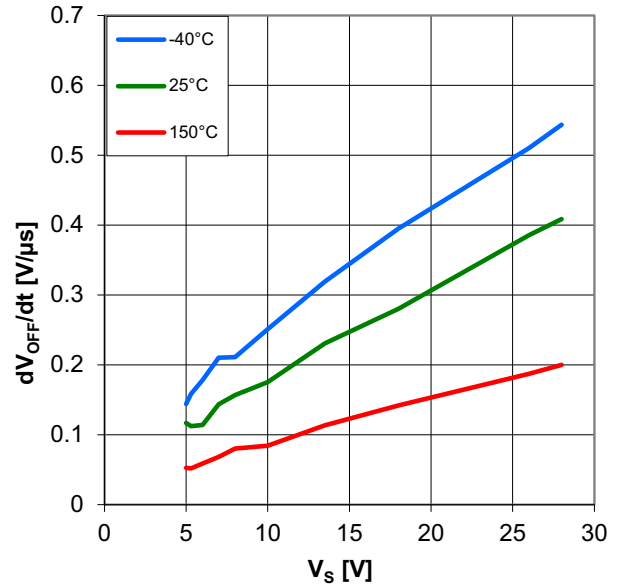

**Switch ON Energy**

$E_{ON} = f(V_S, T_J), R_L = 0.5 \Omega$

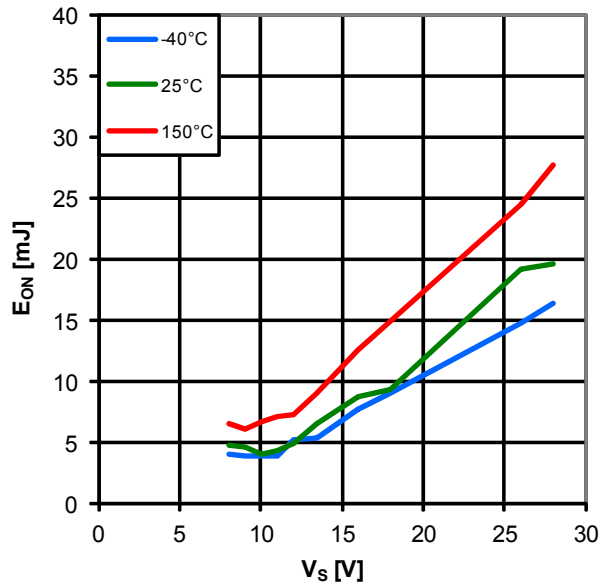

**Switch OFF Energy**

$E_{OFF} = f(V_S, T_J), R_L = 0.5 \Omega$

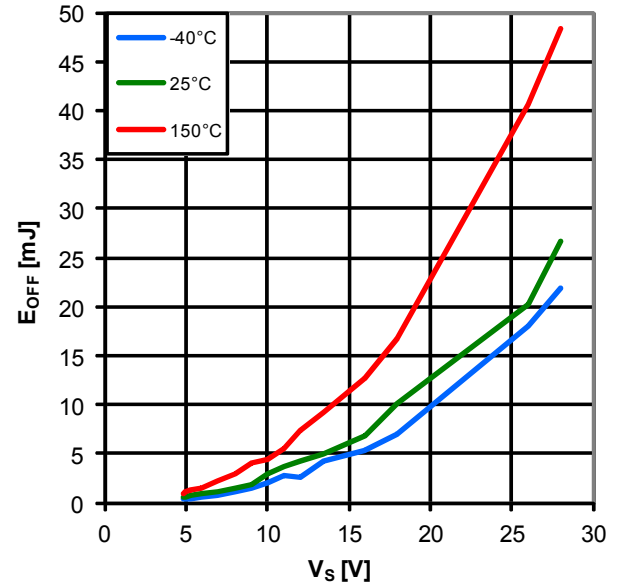

**Electrical Characteristics BTS50015-1TAD**

**Drain to Source Clamp Voltage**

$V_{DS(CL)} = f(T_J), I_L = 50 \text{ mA}$

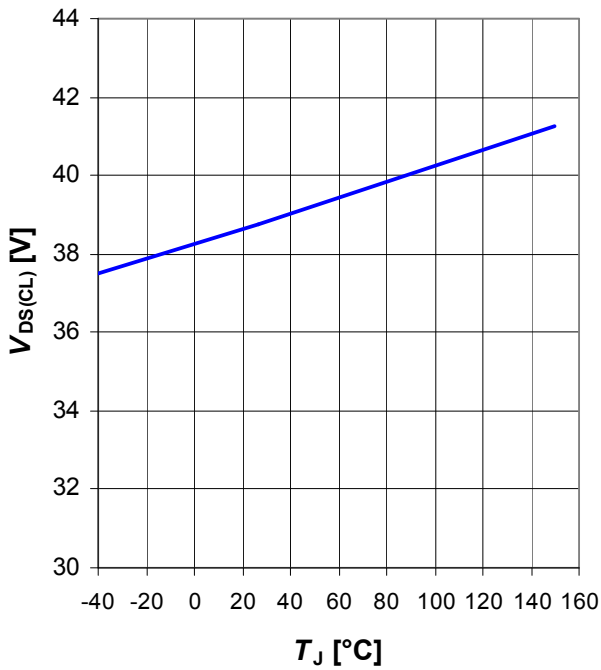

**Overvoltage Protection**

$V_{S(AZ\_GND)} = f(T_J), V_{S(AZ\_IS)} = f(T_J)$

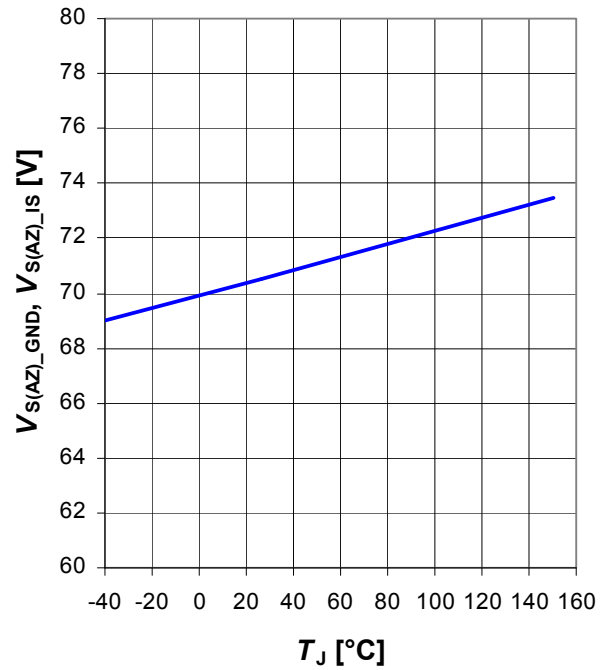

**LOW Level Input Voltage**

$V_{IN(L)} = f(V_S, T_J)$

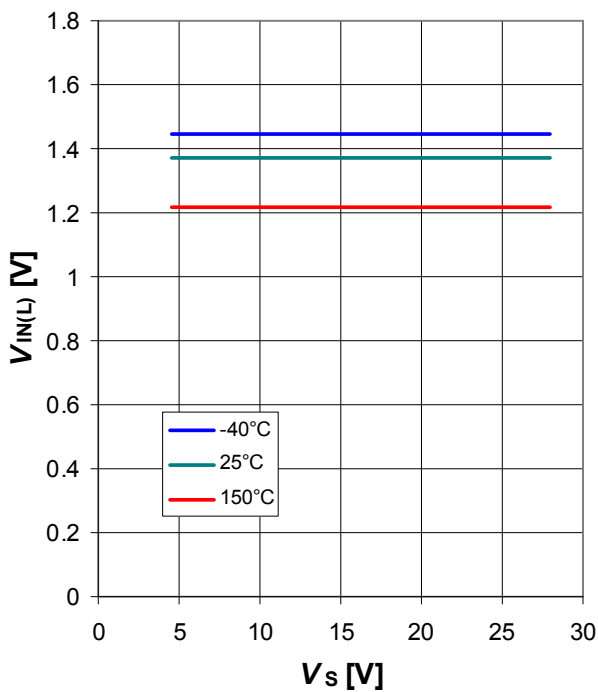

**HIGH Level Input Voltage**

$V_{IN(H)} = f(V_S, T_J)$

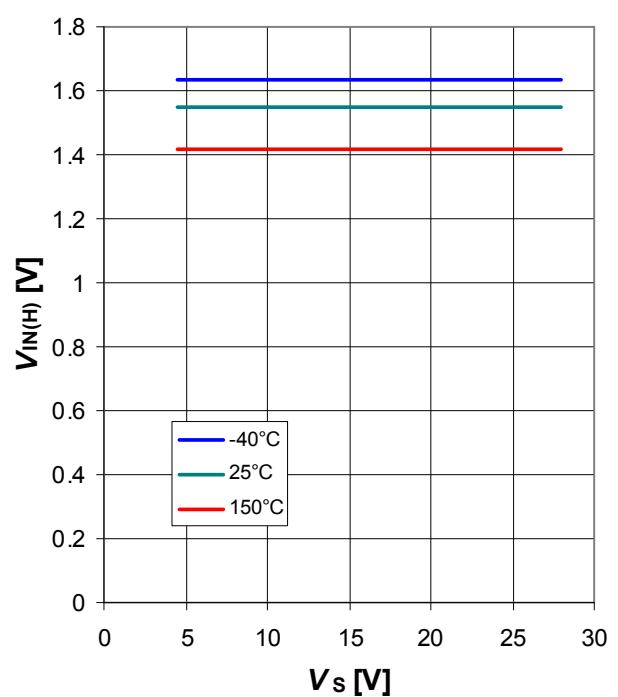

**Electrical Characteristics BTS50015-1TAD**

**Output Leakage Current while Device GND Disconnected,  $I_{OUT(GND)} = f(V_S, T_J)$**

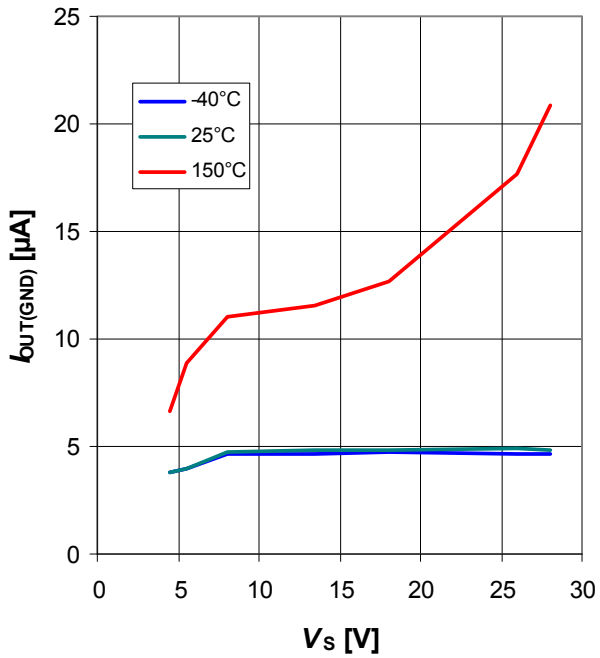

**Overload Detection Current  $I_{CL(1)} = f(dI_L/dt, T_J), V_S = 13.5$  V**

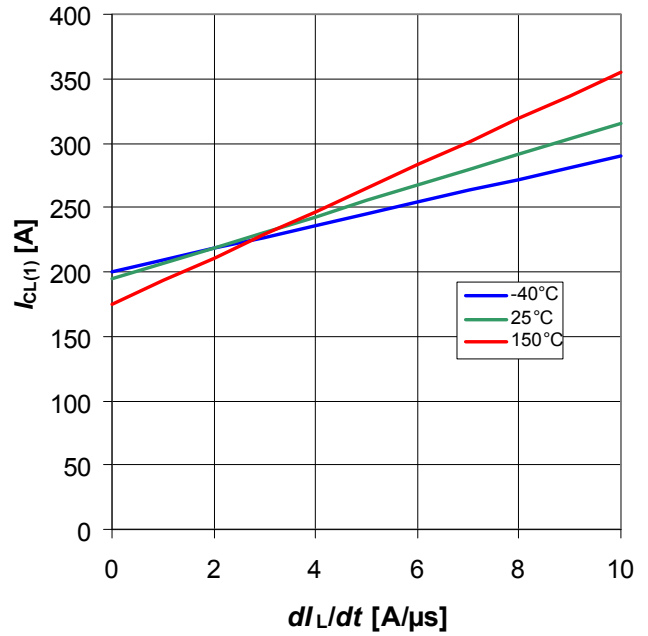

**Resistance in Reversave™  $R_{DS(REV)} = f(V_S, T_J), I_L = -120$  A**

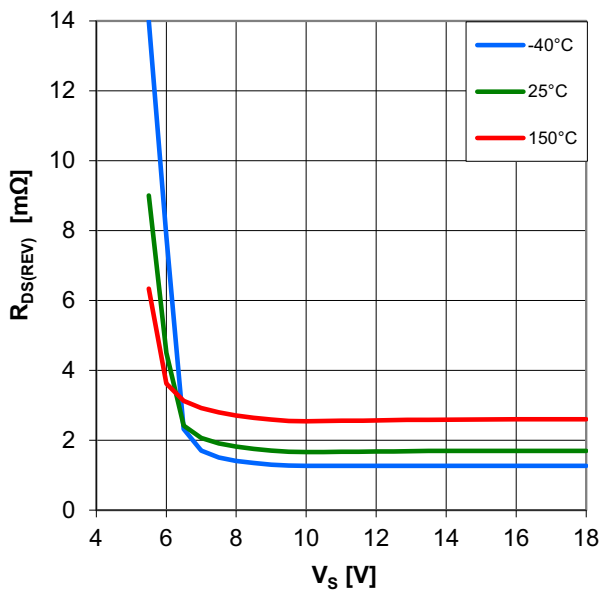

**Resistance in Reversave™  $R_{DS(REV)} = f(V_S, T_J), I_L = -20$  A**

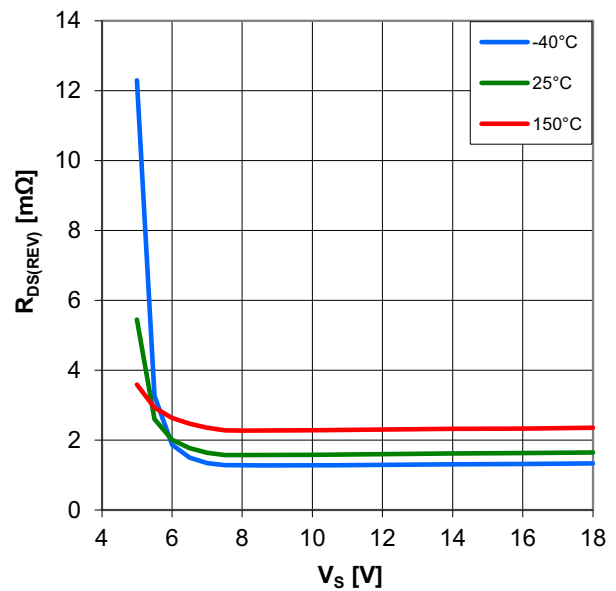

**Electrical Characteristics BTS50015-1TAD**

**Input Current**

$I_{IN} = f(T_J); V_S = 13.5 \text{ V}; V_{IN(L)} = 0.8 \text{ V}; V_{IN(H)} = 5.0 \text{ V}$

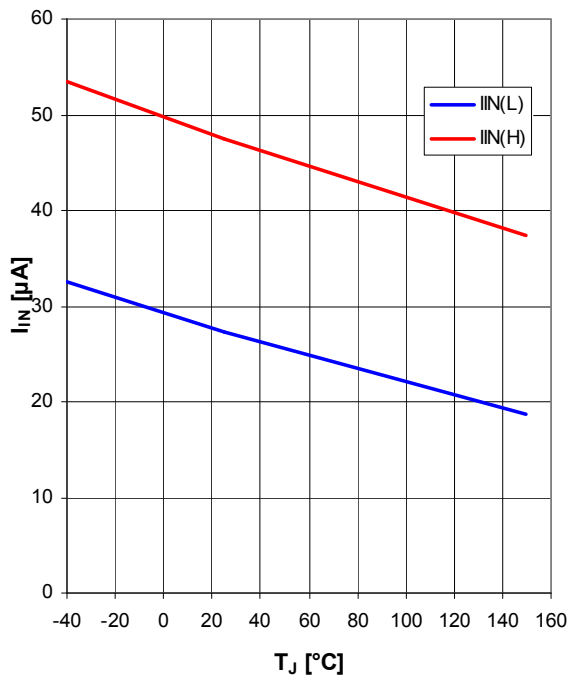

**Input Current**

$I_{IN} = f(V_{IN}, T_J); V_S = 13.5 \text{ V}$

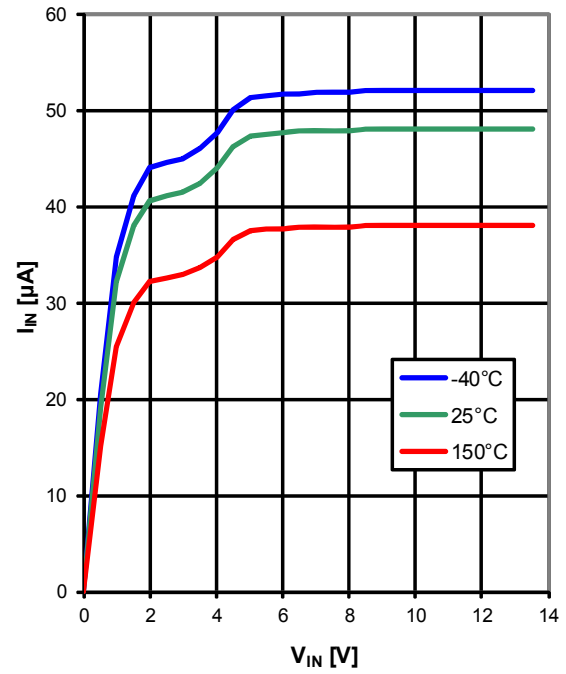

**GND current**

$I_{GND(ACTIVE)} = f(V_S, T_J); V_{IN} = 2.2 \text{ V}$

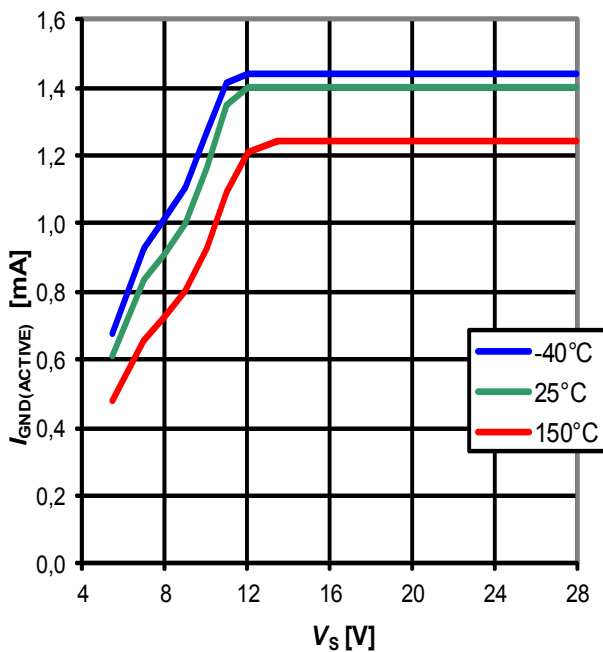

**Application Information**

**7 Application Information**

*Note: The following information is given as a hint for the implementation of the device only and shall not be regarded as a description or warranty of a certain functionality, condition or quality of the device.*

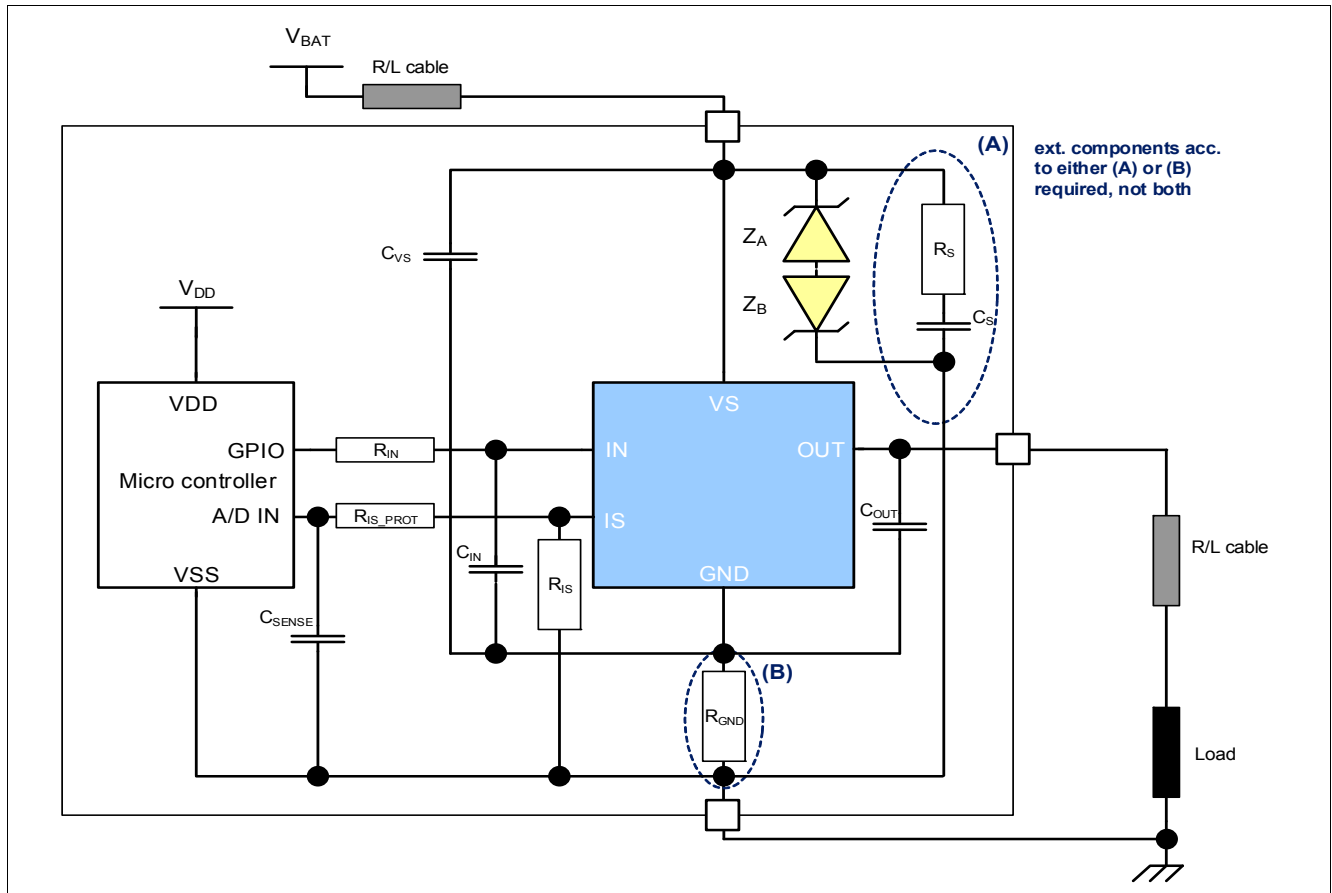

**Figure 30 Application Diagram with BTS50015-1TAD**

*Note: This is a very simplified example of an application circuit. The function must be verified in the real application.*

**Application Information**

**Table 7 Bill of material**

Reference	Value	Purpose
$R_{GND}$	4 $\Omega$	Resistor of RC snubber network Option B, damps possible oscillation of the VS pin voltage in combination with $C_{VS}$
$R_{IN}$	4.7 k $\Omega$	Protection of the microcontroller during overvoltage, reverse polarity allows BTS50015-1TAD channels OFF during loss of ground
$R_{IS}$	1 k $\Omega$	Sense resistor
$R_{IS\_PROT}$	4.7 k $\Omega$	Protection of the microcontroller during overvoltage Protection of the BTS50015-1TAD during reverse polarity
$R_S$	3.9 $\Omega$	Resistor of RC snubber network Option A, damps possible oscillation of the VS pin voltage with improved EMC behavior
$Z_a$	Zener diode	Protection of the BTS50015-1TAD during loss of load with primary charged inductance, see <a href="#">Chapter 5.3.2</a>
$Z_b$	Zener diode	Protection of the BTS50015-1TAD during loss of battery or against huge negative pulse at OUT (like ISO pulse 1), see <a href="#">Chapter 5.3.2</a>
$C_{SENSE}$	10 nF	Sense signal filtering
$C_{VS}$	100 nF	Improved EMC behavior (in layout, pls. place close to the pins)
$C_{OUT}$	10 nF	Improved EMC behavior (in layout, pls. place close to the pins)
$C_{IN}$	150 nF	BTS50015-1TAD tends to latched switch-off due to short negative transients on supply pin; $C_{IN}$ automatically resets the device
$C_S$	4.7 $\mu$ F	Capacitor of RC snubber network Option A, damps possible oscillation of the VS pin voltage with improved EMC behavior

**7.1 Further Application Information**

- Please contact us for information regarding the pin FMEA
- For further information you may contact <http://www.infineon.com/>



## 8 Package Outlines

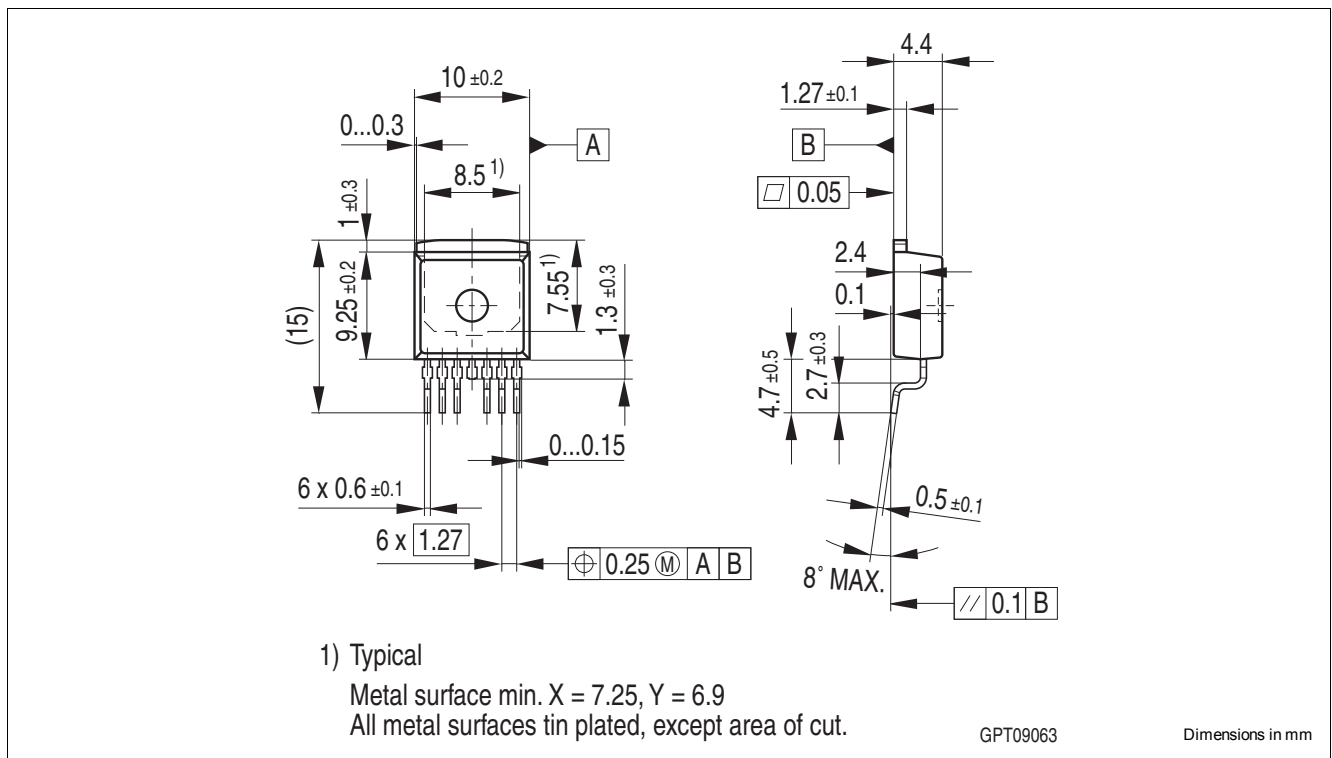

**Figure 31 PG-TO-263-7-8 (RoHS-Compliant)**

### Green Product (RoHS compliant)

To meet the world-wide customer requirements for environmentally friendly products and to be compliant with government regulations the device is available as a green product. Green products are RoHS-Compliant (i.e Pb-free finish on leads and suitable for Pb-free soldering according to IPC/JEDEC J-STD-020).

**Revision History**

## **9 Revision History**

<b>Revision</b>	<b>Date</b>	<b>Changes</b>
1.0	2016-02-26	Data Sheet created.

#### Trademarks of Infineon Technologies AG

$\mu$ HVIC™,  $\mu$ IPM™,  $\mu$ PFC™, AU-ConvertIR™, AURIX™, C166™, CanPAK™, CIPOS™, CIPURSE™, CoolDP™, CoolGaN™, COOLiR™, CoolMOS™, CoolSET™, CoolSiC™, DAVE™, DI-POL™, DirectFET™, DrBlade™, EasyPIM™, EconoBRIDGE™, EconoDUAL™, EconoPACK™, EconoPIM™, EiceDRIVER™, eupec™, FCOS™, GaNpowIR™, HEXFET™, HITFET™, HybridPACK™, iMOTION™, IRAM™, ISOFACE™, IsoPACK™, LEDriviR™, LITIX™, MIPAQ™, ModSTACK™, my-d™, NovalithIC™, OPTIGA™, OptiMOS™, ORIGA™, PowIRaudio™, PowIRstage™, PrimePACK™, PrimeSTACK™, PROFET™, PRO-SIL™, RASIC™, REAL3™, SmartLEWIS™, SOLID FLASH™, SPOC™, StrongIRFET™, SupIRBuck™, TEMPFET™, TRENCHSTOP™, TriCore™, UHVIC™, XHP™, XMC™.

Trademarks updated November 2015

#### Other Trademarks

All referenced product or service names and trademarks are the property of their respective owners.

**Edition 2016-02-26**

**Published by**

**Infineon Technologies AG**

**81726 Munich, Germany**

**© 2016 Infineon Technologies AG.**

**All Rights Reserved.**

**Do you have a question about any aspect of this document?**

**Email: [erratum@infineon.com](mailto:erratum@infineon.com)**

#### IMPORTANT NOTICE

The information given in this document shall in no event be regarded as a guarantee of conditions or characteristics ("Beschaffenheitsgarantie").

With respect to any examples, hints or any typical values stated herein and/or any information regarding the application of the product, Infineon Technologies hereby disclaims any and all warranties and liabilities of any kind, including without limitation warranties of non-infringement of intellectual property rights of any third party.

In addition, any information given in this document is subject to customer's compliance with its obligations stated in this document and any applicable legal requirements, norms and standards concerning customer's products and any use of the product of Infineon Technologies in customer's applications.

The data contained in this document is exclusively intended for technically trained staff. It is the responsibility of customer's technical departments to evaluate the suitability of the product for the intended application and the completeness of the product information given in this document with respect to such application.

For further information on technology, delivery terms and conditions and prices, please contact the nearest Infineon Technologies Office ([www.infineon.com](http://www.infineon.com)).

#### WARNINGS

Due to technical requirements products may contain dangerous substances. For information on the types in question please contact your nearest Infineon Technologies office.

Except as otherwise explicitly approved by Infineon Technologies in a written document signed by authorized representatives of Infineon Technologies, Infineon Technologies' products may not be used in any applications where a failure of the product or any consequences of the use thereof can reasonably be expected to result in personal injury.