

BT122 Data Sheet

BT122 is a dual mode Bluetooth BR/EDR - BLE module targeted for applications that require both Bluetooth Low Energy and Classic connectivity. It can connect to legacy devices that only support Bluetooth SPP or Apple® iAP2 profiles as well to devices that support Bluetooth Low Energy. BT122 integrates a high performance Bluetooth radio, a low power ARM Cortex micro-controller and a Silicon Labs Dual Mode stack software. BT122 can be used as a modem together with a separate host MCU, but applications can also be embedded into the built-in ARM® Cortex® MCU with the Silicon Labs BGScript™ scripting language.

KEY FEATURES

- Integrated dual mode BLE and BR/EDR stack
- Bluetooth v4.2 compliant, tested against v5.1
- BGAPI™ serial protocol API
- Built-in antenna
- Up to 11 dBm TX power
- -95 dBm RX sensitivity
- 32-bit ARM Cortex-M4 core
- 256/32 kB of Flash/RAM memory
- Up to 10 x GPIO
- 11.6 mm x 16.0 x 2.2 mm

BT122 MODULE

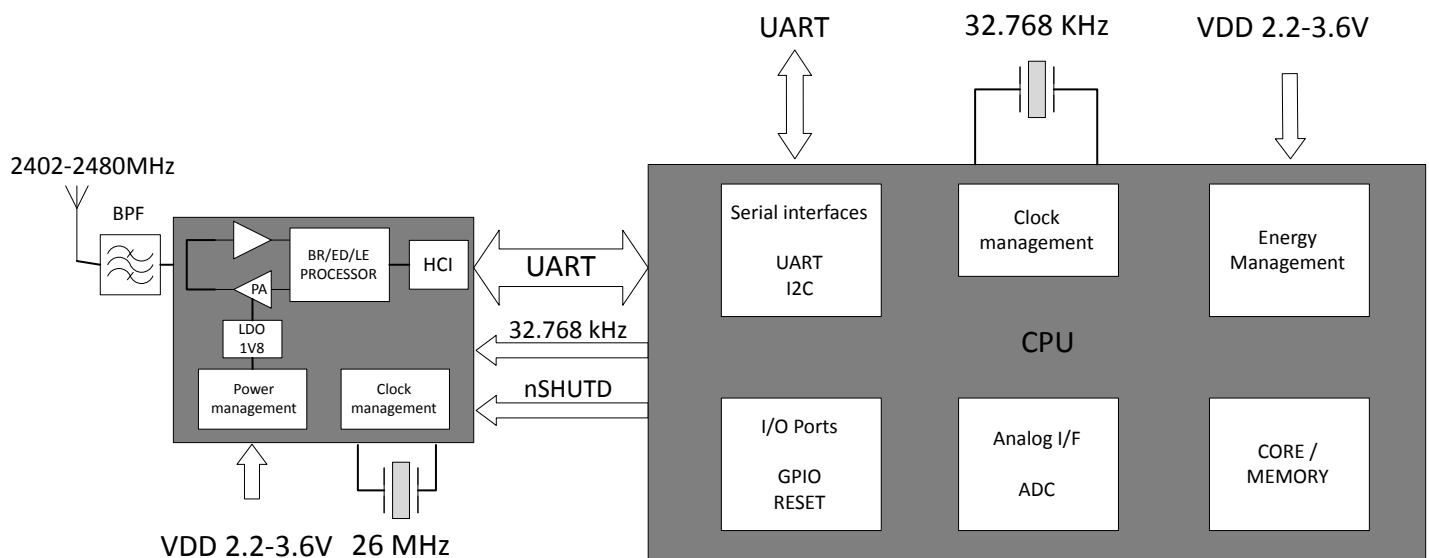

Table of Contents

1. Feature List	4
2. Typical Applications	5
3. Design Guidelines	6
3.1 PCB Layout Recommendations	6
3.2 Power Supply Recommendations	6
3.3 Software Application-Related Options	6
3.4 Firmware Updating Related Recommendations	7
4. Pin-Out Description	8
4.1 Power, Ground, Reset, and GPIO Pins	8
4.2 GPIO Pins	9
5. Power Control	10
5.1 Power Supply Requirements	10
5.2 Power Saving Functionality	10
5.2.1 Power Mode 1	10
5.2.2 Power Mode 2	10
5.2.3 Wake-Up Pin Functionality	11
5.3 Reset	11
6. Interface	12
6.1 GPIO	12
6.2 UART	12
6.3 I ² C	12
6.4 ADC	12
6.5 Real-Time Clock	12
6.6 Microcontroller Programming Interface	12
7. Antenna	13
7.1 Measured Antenna Efficiency	13
7.2 Measured 2D Radiation Patterns	15
7.3 Measured 3D Radiation Patterns	18
8. Bluetooth® Software Stack	20
9. Host Interface	21
9.1 UART	21
10. Connection Examples	22
10.1 Connecting an External Host Using the UART Interface	22
10.2 Connecting an External Device Using I ² C Interface	23

11. Electrical Characteristics	24
11.1 Absolute Maximum Ratings	.24
11.2 Recommended Operating Conditions	.24
11.3 Logic Signal Characteristics	.24
11.3.1 Digital I/O	.24
11.3.2 Reset	.25
11.3.3 ADC	.25
11.4 Power Consumption	.26
12. RF Characteristics	27
13. Packaging Specifications	28
13.1 Dimensions	.28
13.2 PCB Landing Pattern	.28
13.3 Package Marking	.29
14. Soldering Recommendations	30
15. Tape and Reel Packaging	31
15.1 Reel Material and Dimensions	.31
15.2 Tape Material and Dimensions	.32
16. Certifications	33
16.1 EU and UK - CE and UKCA	.33
16.2 USA - FCC	.33
16.3 Canada - ISED	.35
16.4 Proximity to Human Body	.37
16.5 Japan - MIC	.38
16.6 South Korea - KC	.39
16.7 China - SRRC	.39
16.8 Bluetooth Qualification	.39
17. Ordering Guide	40
18. Revision History	41

1. Feature List

- **Bluetooth Features**
 - Bluetooth v4.2 BR/EDR and BLE compliant
 - Up to 6 x BR/EDR connections
 - Up to 7 x BLE connections
 - 1 x BR/EDR + 6 x BLE connections simultaneously
 - Scatternet: 3 simultaneous piconets
- **Radio Features**
 - Integrated antenna
 - TX Power, BR +11dBm, EDR +5dBm and LE +7dBm
 - RX Sensitivity -95 dBm
 - 400-550 meter LoS range
- **Software Features**
 - Integrated Bluetooth BR/EDR and BLE stack
 - SPP, iAP2, HID and GATT over BR Bluetooth profiles
 - Any GATT based BLE
 - SPP supports up to 1000 kbps
 - BGAPI™ serial protocol API over UART for network co-processor usage
 - BGLIB™ host C library which implements BGAPI serial protocol
 - BGScript™ scripting language for standalone usage
- **Hardware Interfaces**
 - UART host interface
 - UART and I2C peripheral interfaces
 - Up to 10 x GPIO with interrupts
 - 3 x 12-bit ADC
 - Internal battery voltage measurement option
 - Microcontroller ARM Cortex-M4
 - 40 MHz
 - 32 kB RAM
 - 256 kB flash
- **Electrical Characteristics**
 - Supply voltage: 2.2V to 3.6V
 - Temperature range: -40°C to +85°C
 - Bluetooth qualified
 - Regulatory Certified: CE (EU), UKCA (UK), FCC (USA), ISED (Canada), MIC (Japan), KC (South Korea) and SRRC (China)
 - Dimensions: 11.62 mm x 16.0 mm x 2.2 mm (W x L x H)

2. Typical Applications

BT122 can be used in a wide variety of applications such as cable replacement, HID devices, health and fitness, PoS (point-of-sales), M2M connectivity, industrial and home automation gateways and others.

3. Design Guidelines

Certain hardware related design guidelines should always be followed when developing applications based on the BT122 module.

3.1 PCB Layout Recommendations

- All ground pads should be connected to a ground plane.
- The antenna layout should follow the example shown in the figure below and avoid the designs shown as crossed over.
- BT122 requires minimal free space around the module and only the white area marked in the PCB picture series presented in [Figure 3.1 PCB Layout Recommendations for the BT122 Boards on page 6](#) below needs to be free of copper and components.

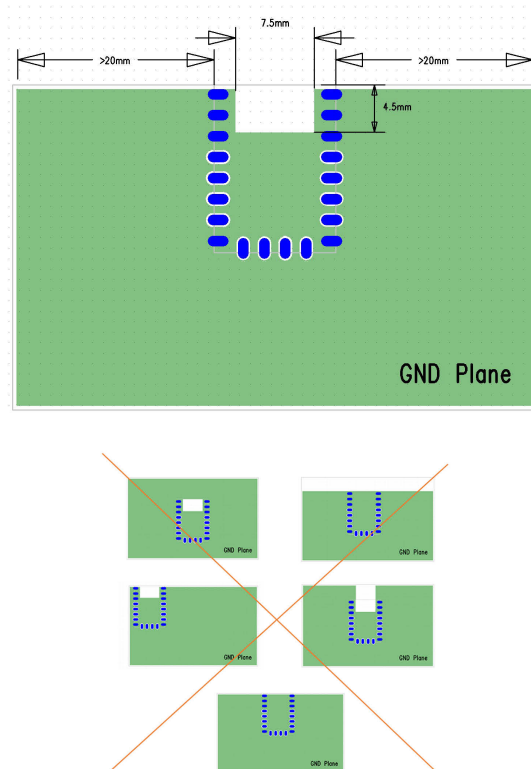

Figure 3.1. PCB Layout Recommendations for the BT122 Boards

3.2 Power Supply Recommendations

The regulator used must be capable of supplying a peak current of 150 mA and the regulator must be of a type stable with ceramic capacitors.

3.3 Software Application-Related Options

BT122 can be used either as a stand-alone solution by using the BGScript™ scripting language or alternatively, if the application software size or other factors require - together with an external host processor by using BGAPI™ commands. The decision on which approach to use is most often dictated by use-case scenario .

3.4 Firmware Updating Related Recommendations

To enable firmware updating an external UART interface connection as shown in [Figure 3.2 Example: BT122 Firmware Update via UART Connections on page 7](#) is mandatory. BT122 firmware can be updated through the UART interface by holding the host MCU in reset state which typically will free the UART lines to be used by the update interface.

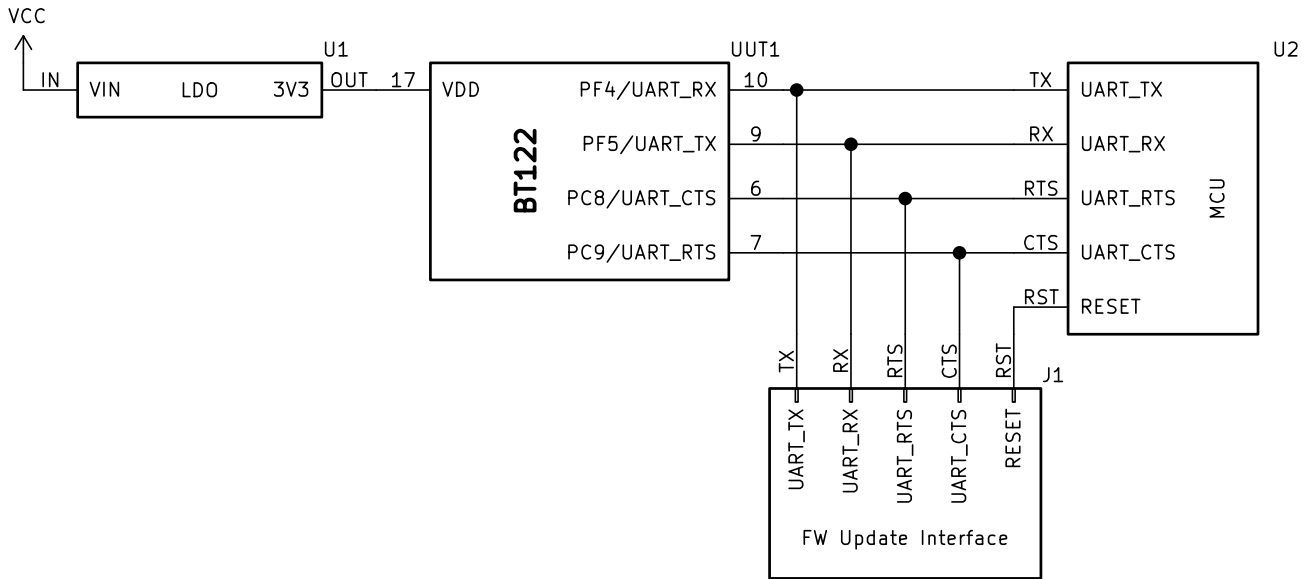

Figure 3.2. Example: BT122 Firmware Update via UART Connections

Another way to update BT122 firmware is used J-Link programmer. In this case SWD debug interface is used. [Figure 3.3 BT122 Firmware Update via J-Link Debugger and SWD Interface on page 7](#) presents pinout connection for proper work of programmer.

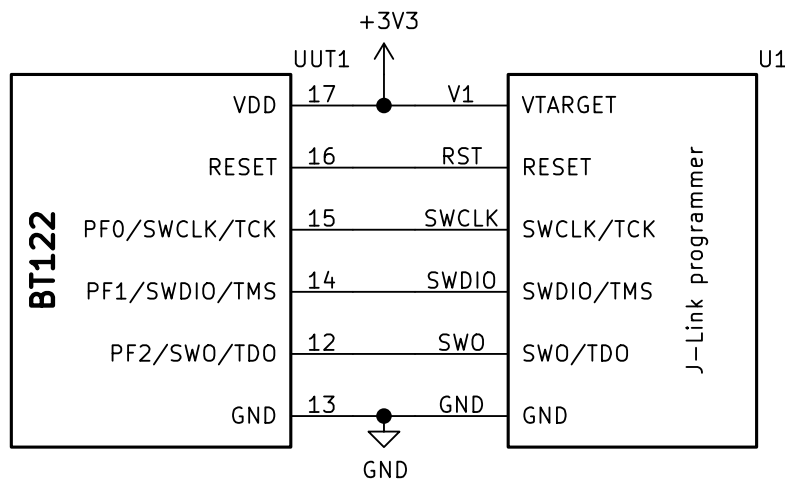

Figure 3.3. BT122 Firmware Update via J-Link Debugger and SWD Interface

4. Pin-Out Description

This section contains a description of the BT122 pin-out. Each pin may have one or more functions which are all listed in tables. The pin-out is shown in the figure below

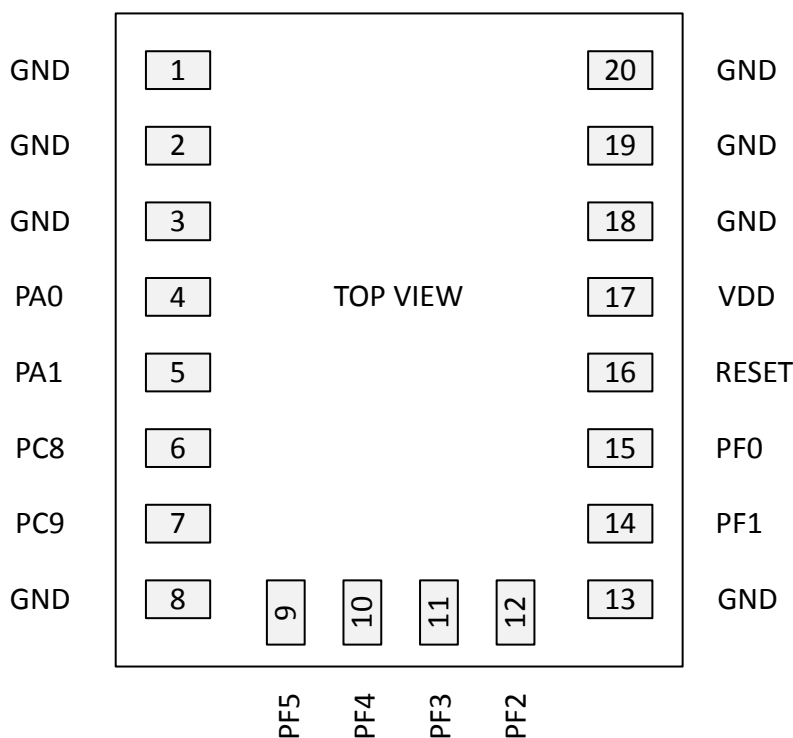

Figure 4.1. BTT122 Pin-Out (Top View)

4.1 Power, Ground, Reset, and GPIO Pins

Power supply, ground, reset signal, GPIO related pins are listed in the table below.

Table 4.1. Power, Ground, Reset, and GPIO Pins

Pin /Pad	Function	Description
17	VDD	Module power supply input pins.
1,2,3,8,13,18, 19,20	GND	Ground pin. These are all connected together internally but they should all be individually connected directly to a solid ground plane with vias in close proximity to the pins. This requirement concerns especially the antenna connections.
16	RESET	Module reset signal pins. Reset input, active low. To apply an external reset source to this pin, it is required to only drive this pin low during reset, and let the internal pull-up ensure that reset is released.
4,5,6,7,9,10, 11,12,14,15	GPIO	General purpose Input/Output

4.2 GPIO Pins

General purpose I/O pins and their functions are listed below.

Table 4.2. General Purpose I/O Pins and Their Functions

Peripheral Function	GPIO Name									
	PA0	PA1	PC8	PC9	PF0	PF1	PF2	PF3	PF4	PF5
Pin Number	4	5	6	7	15	14	12	11	10	9
5V Tolerant	N	N	Y	Y	Y	Y	Y	Y	Y	Y
UART			CTS	RTS					RX	TX
I²C	SCL	SDA								
ADC Input	ADC_CH0	ADC_CH1						ADC_CH2		
Programming Interface					SWCLK/ TCK	SWDIO/ TMS	SWO/ TDO	TDI		

5. Power Control

5.1 Power Supply Requirements

BT122 is powered by a single power supply input (VDD). Nominal input voltage is 3.3 VDC and input voltage range 2.2 V to 3.6 V. If the module's internal ADC functions are used minimum allowed power supply voltage is 2.4V. PA of BT122 is fully internally regulated.

The VDD supply should be capable of supplying a peak current of at least 150 mA even though the average current consumption of BT122 will be much less than that. External high frequency bypass capacitors are not needed because the module contains the necessary power supply filtering capacitors.

Careful design of the layout and proper component selection are necessary to prevent switching noise from appearing on the supply line. Such disturbances can be caused by on-board charge pump converters (e.g. RS232 level shifters). Charge-pump-based converters tend to have strong switching spikes which are difficult to filter out and may degrade RF performance. A ferrite chip can be added in series with the supply line close to the module supply pin to reduce RF interference through the supply line.

There is a total of about 1.5 μF of ceramic capacitors on the VDD line inside the module. When using low drop linear regulators to generate a regulated supply voltage for the VDD line, the stability of the regulator with the low ESR provided by these capacitors should be checked. Many linear regulators and some switched mode ones too are not stable when used with ceramic output capacitors. The regulator datasheets usually have recommendations for output capacitor ESR range or they contain a stability curve to help select components properly. A regulator designated as "stable with ceramic capacitors" is recommended.

5.2 Power Saving Functionality

BT122 contains two configurable power saving modes. The internal RTC (Real Time Clock) is usually kept always running to avoid the long wake-up time associated with the internal 32 kHz crystal oscillator. The RTC is always available to wake up the module.

5.2.1 Power Mode 1

Power mode 1 is a sleep state with all clocks and peripherals running but with the processor core stopped. It is used automatically and has no impact on module performance and does not require special considerations in user applications. See [Table 5.1 Power Modes with Corresponding Wakeup Delays and Current Consumption on page 11](#).

5.2.2 Power Mode 2

Power mode 2 is a deep sleep state, in which most peripheral devices and system clocks are powered down. The UART interfaces cannot operate without clocks, and instant communications with the host are not possible. A separate wake-up pin can be used to wake up the module, which will stay on as long as the wakeup pin is held high. GPIO interrupts, activity on the radio and RTC interrupts can also cause a wake-up event. There is a short wake-up delay due to the time required for the internal clocks to stabilize and because of this the module processor is not instantly ready to receive data. See [Table 5.1 Power Modes with Corresponding Wakeup Delays and Current Consumption on page 11](#).

5.2.3 Wake-Up Pin Functionality

This feature can be used to prevent the *Bluetooth* module from entering a sleep mode or alternatively can be used to wake it up from a sleep mode. If the sleep modes have been enabled in the hardware configuration file (see *Bluetooth Dual Mode Configuration Guide*) and UART is used to communicate with the module, then this feature must be enabled and the wake-up pin must be asserted before sending any data or BGAPI™ commands to the module, and also kept asserted until the last byte has been transferred into the module over the UART.

The wake-up pin functionality can only be assigned to a single GPIO, but it is still possible to assign normal GPIO interrupts to other pins. The difference between the wake-up pin and normal GPIO interrupts is that the wake-up pin will not only generate the interrupt which wakes the module but will also keep the module awake if it is held in the asserted state. Normal GPIO interrupts can wake the module from any state but after the interrupt event handler completes the module will return to sleep.

There is always a delay before the module wakes up. It is possible to measure the wake-up time by measuring when flow control starts to work. Data should not be sent before the module has woken up to prevent data loss. Monitor the RTS/CTS signal to detect when the module has woken up. There is no special command separately to wake up the module.

Table 5.1. Power Modes with Corresponding Wakeup Delays and Current Consumption

Power Mode	CPU Clocks	CPU Core	Radio	UART
Active	ON	Running	ON	Active
Power mode 1	ON	Sleep	ON	Active
Power mode 2	OFF	Stopped	ON	Off

The logic flow of the power saving modes in relation to each other is shown in the figure below. It is to be noted that the processor will not lose RAM contents regardless of the power mode used.

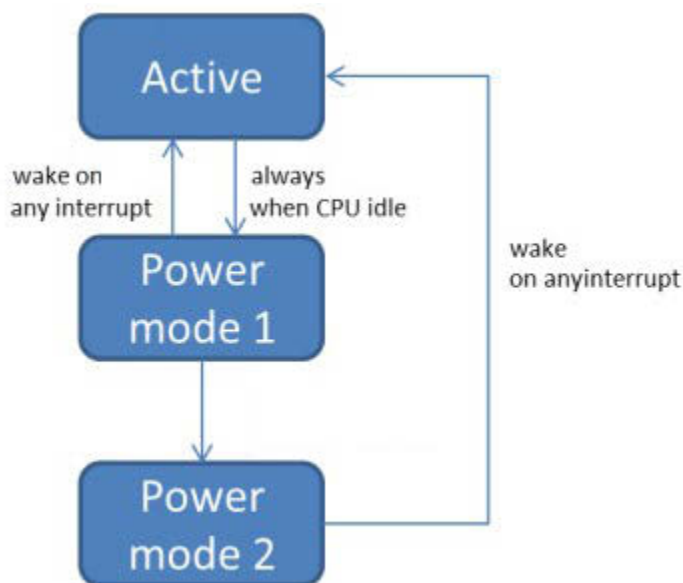

Figure 5.1. Power Modes in Relation to Each Other and to Active Mode

5.3 Reset

BT122 can be reset by several methods: by pulling the RESET pin low, by the internal system power-up reset functionality or by the internal watchdog timer. The RESET pin is internally connected to a pull-up resistor. The RESET pin should be connected to a push-button, header or test point to enable the use of the system recovery mode. On an internal reset, the RESET pin will be briefly pulled low internally. It is recommended that an external reset source is of an open drain type.

6. Interface

6.1 GPIO

BT122 contains several pins which can be configured to operate as general-purpose digital I/Os, analog inputs, or to be used in combination with various built-in functions. The module contains I²C and UART communication. Most of pins (except PA0 and PA1) are 5V tolerant. All GPIO pins can drive current of up to ± 50 mA. Any available GPIO signal can be assigned an interrupt function. However, the module microcontroller has a limited number of interrupt channels available for GPIO. In short, MCU classified interrupts in key of modulo 4. So, for pins with number 0-3 for each port are available only 4 interrupts, and for next pins in the same way.

6.2 UART

There is one UART port available on the BT122. By default, it is used for BGAPI™ host interface, but with BGScript™ it can be used as an application UART. The UART supports all standard baud rates up to 3 Mbps. RTS/CTS handshake scheme is supported and recommended for every application for reliable data transfer.

6.3 I²C

BT122 has one available I2C channel, which support each defined mode:

- *Standard*-up to 100kbps
- *Fast*-up to 400kbs
- *Fast Plus*-up to 1Mbps

6.4 ADC

BT122 contains a 3-channel 12-bit ADC with multiple external input sources as well as an internal battery measurement and temperature measurement possibility. ADC input voltage range is 0 to VDD.

6.5 Real-Time Clock

BT122 contains a real-time clock (RTC) with full calendar support and sub-second resolution. The RTC can be used for periodic or specifically programmed wakeups. The RTC is clocked by an internal crystal oscillator which is always on as long as power is supplied to the module.

6.6 Microcontroller Programming Interface

The preferred method of programming the BT122 is by using DFU through UART host interface. Some problem may occur if bootloader is disabled by disabling the UART or if the bootloader is overwritten accidentally. Then the bootloader would need to be re-uploaded.

Bootloader can be re-uploaded using SWD interfaces and J-Link options in BGTool™. SWD interface should be connected in following pin configuration:

- PF0 – SWDIO
- PF1 – SWCLK
- PF2 – SWO
- RESET – RST

7. Antenna

7.1 Measured Antenna Efficiency

The measured antenna efficiency as a function of frequency is shown in the figure below.

Efficiency (dB)

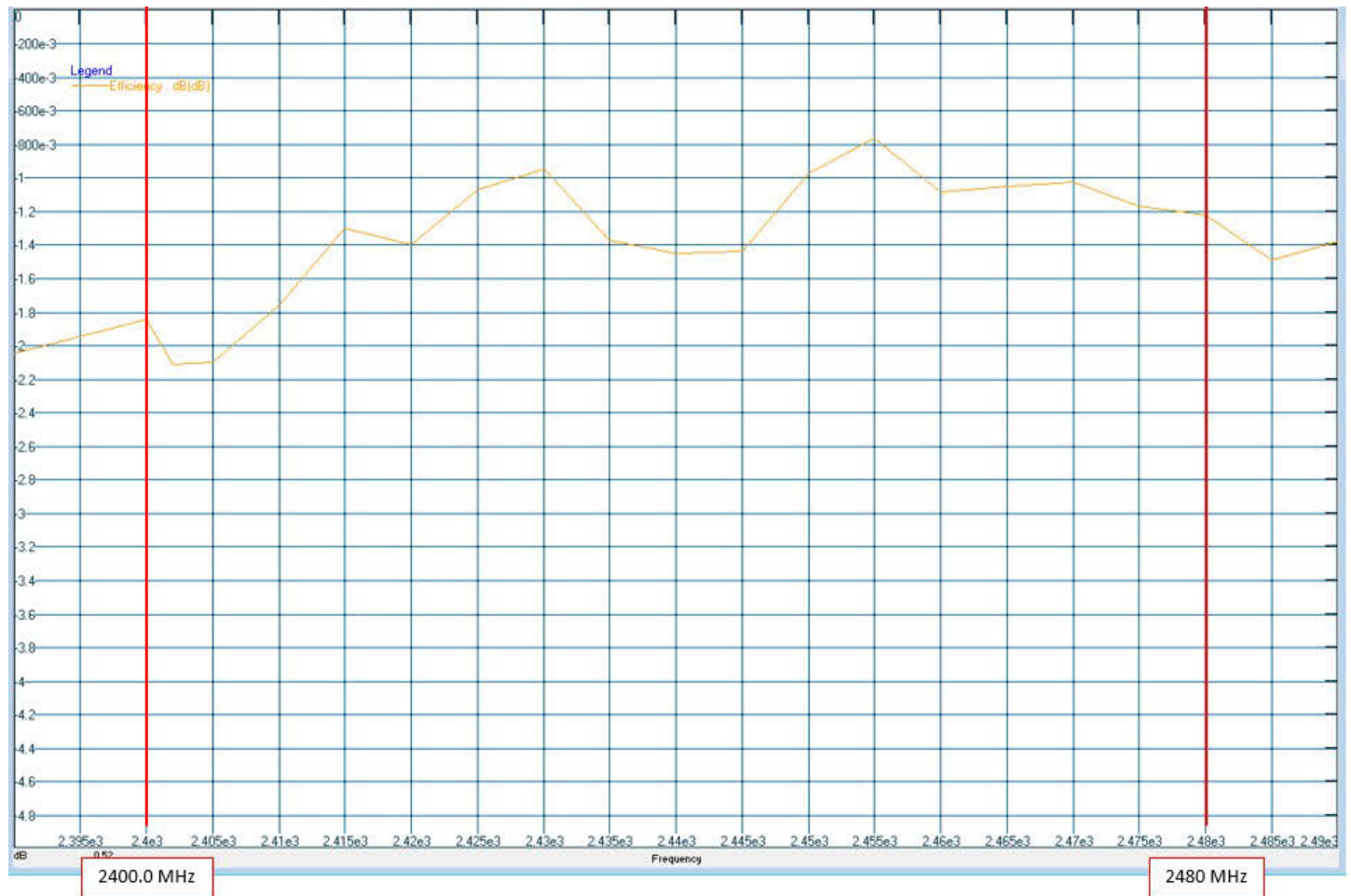

Figure 7.1. Antenna Efficiency Related to Frequency

The measured antenna Peak Gain as a function of frequency is shown in the figure below. Peak gain from plot is 2.1dBi.

Peak Gain (dBi)

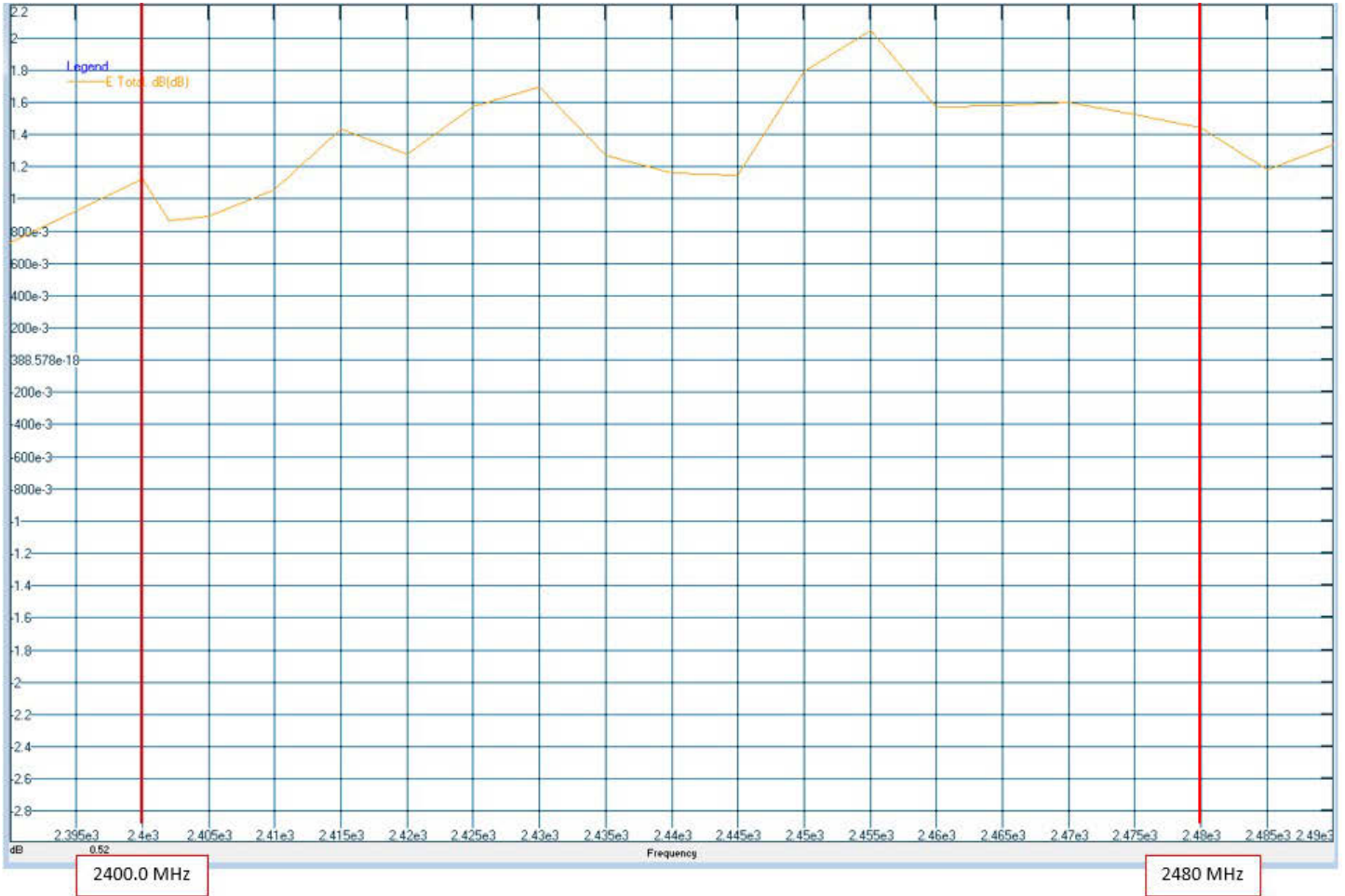

Figure 7.2. Antenna Gain Related to Frequency

The simulated impact to the operating range with different size of GND plane is shown in the figure below.

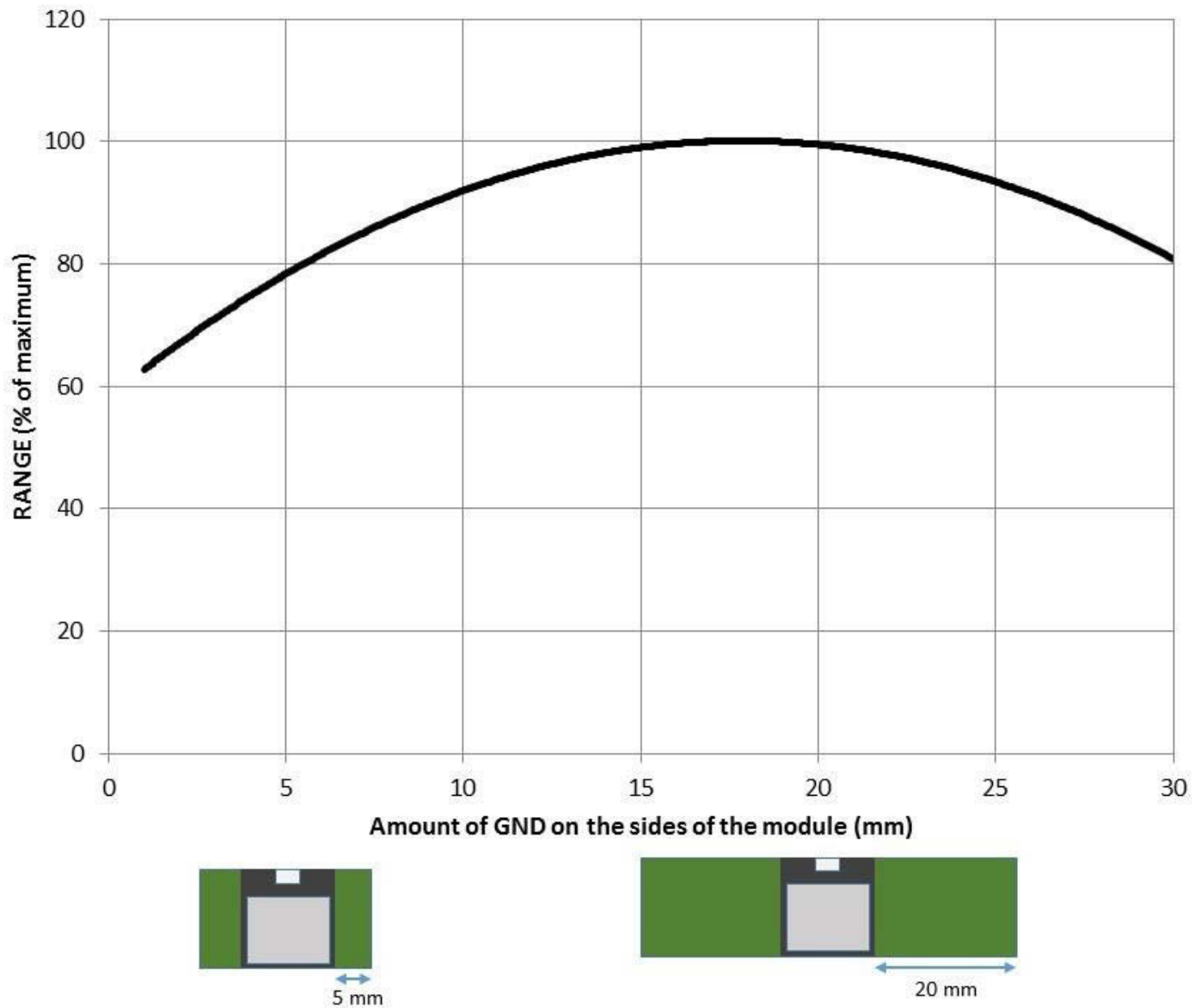

Figure 7.3. Impact of the Size of GND Plane to Range of BT122

7.2 Measured 2D Radiation Patterns

Typical radiation patterns of the BT122 module. 2D plots are shown be in [Figure 7.4 Typical 2D Radiation Pattern for BT122, Phi 0](#) on page 16, [Figure 7.5 Typical 2D Radiation Pattern for BT122, Phi 90](#) on page 17, and [Figure 7.6 Typical 2D Radiation Pattern for BT122, Theta 90](#) on page 18.

Phi0 Gain Cut (dBi)

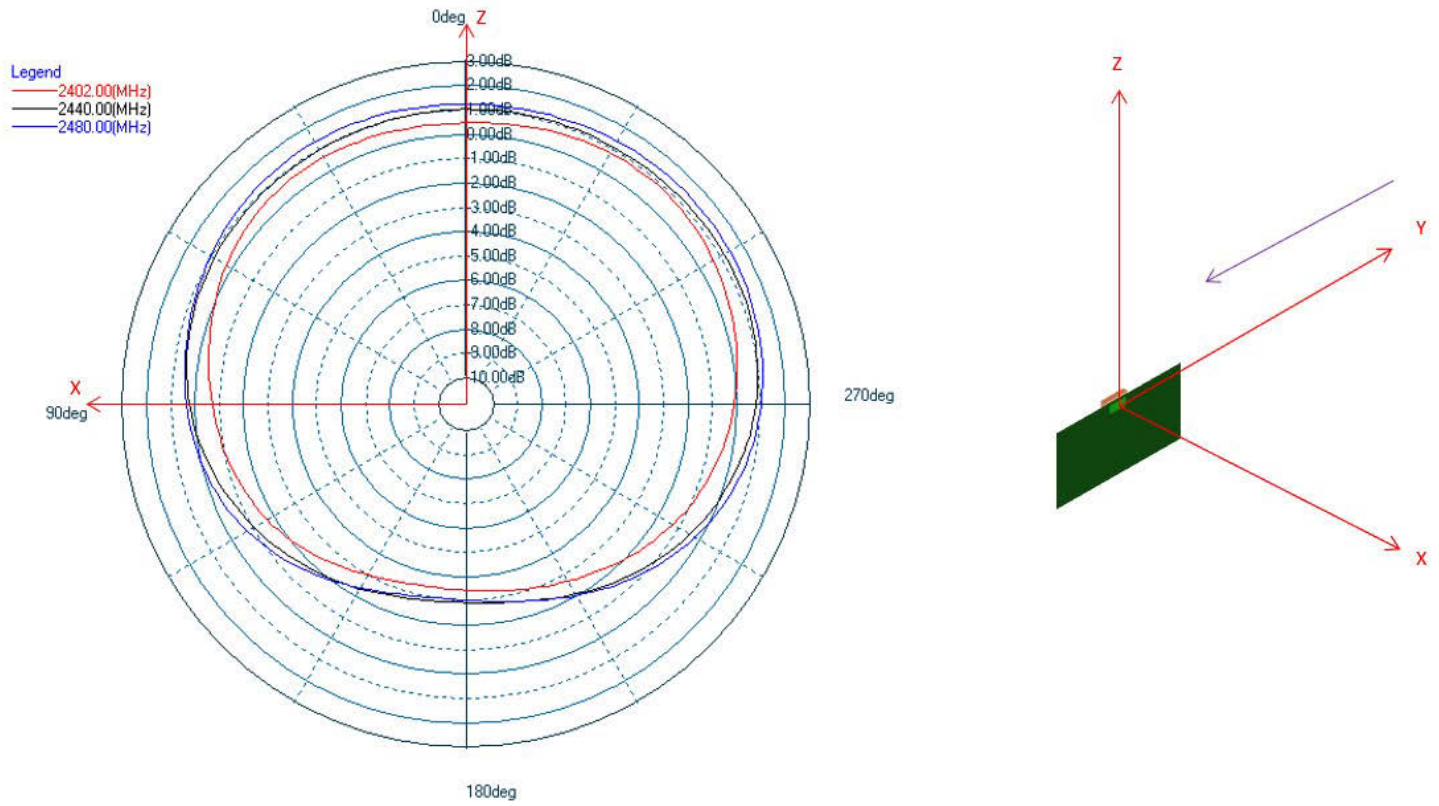

Figure 7.4. Typical 2D Radiation Pattern for BT122, Phi 0

Phi90 Gain Cut

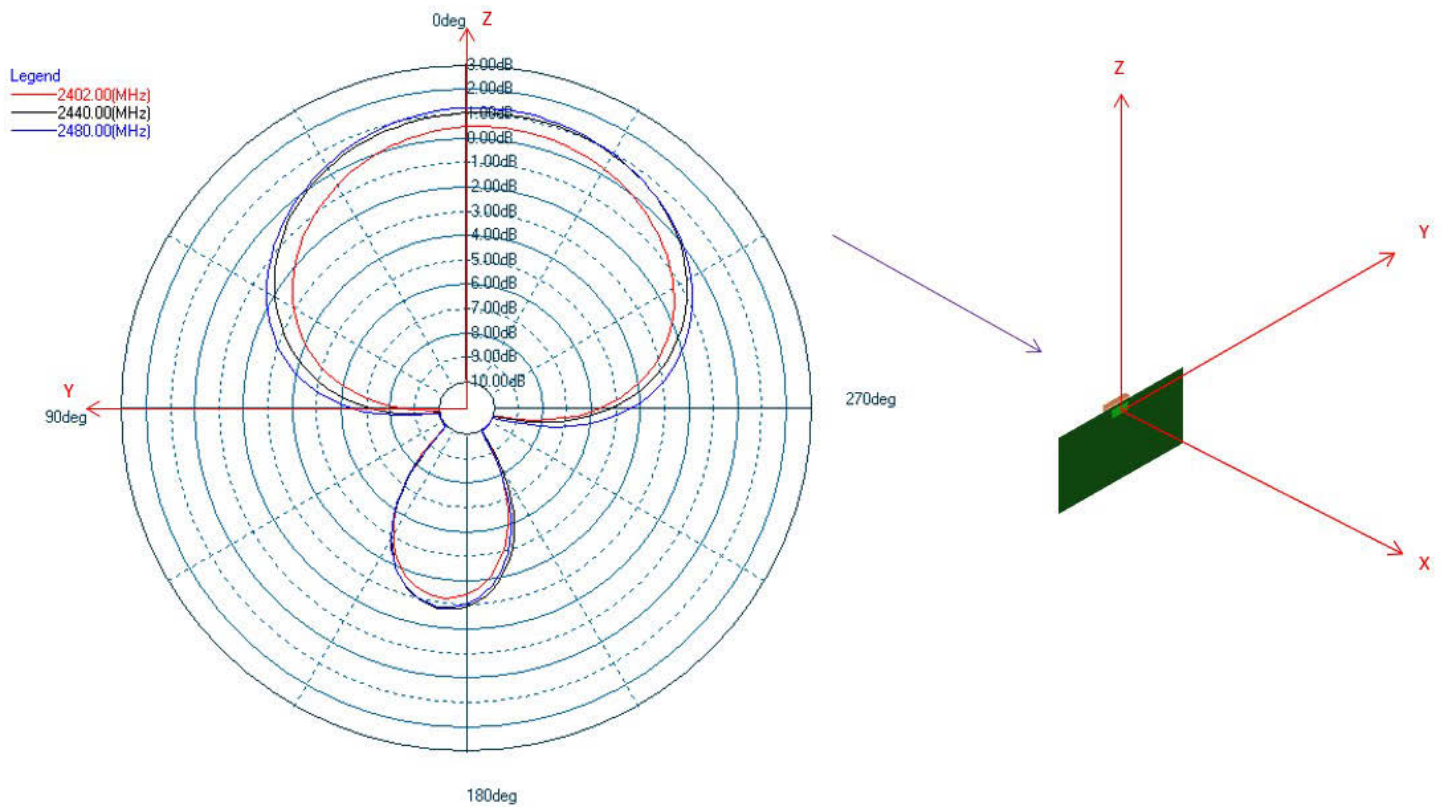

Figure 7.5. Typical 2D Radiation Pattern for BT122, Phi 90

Theta90 Gain Cut

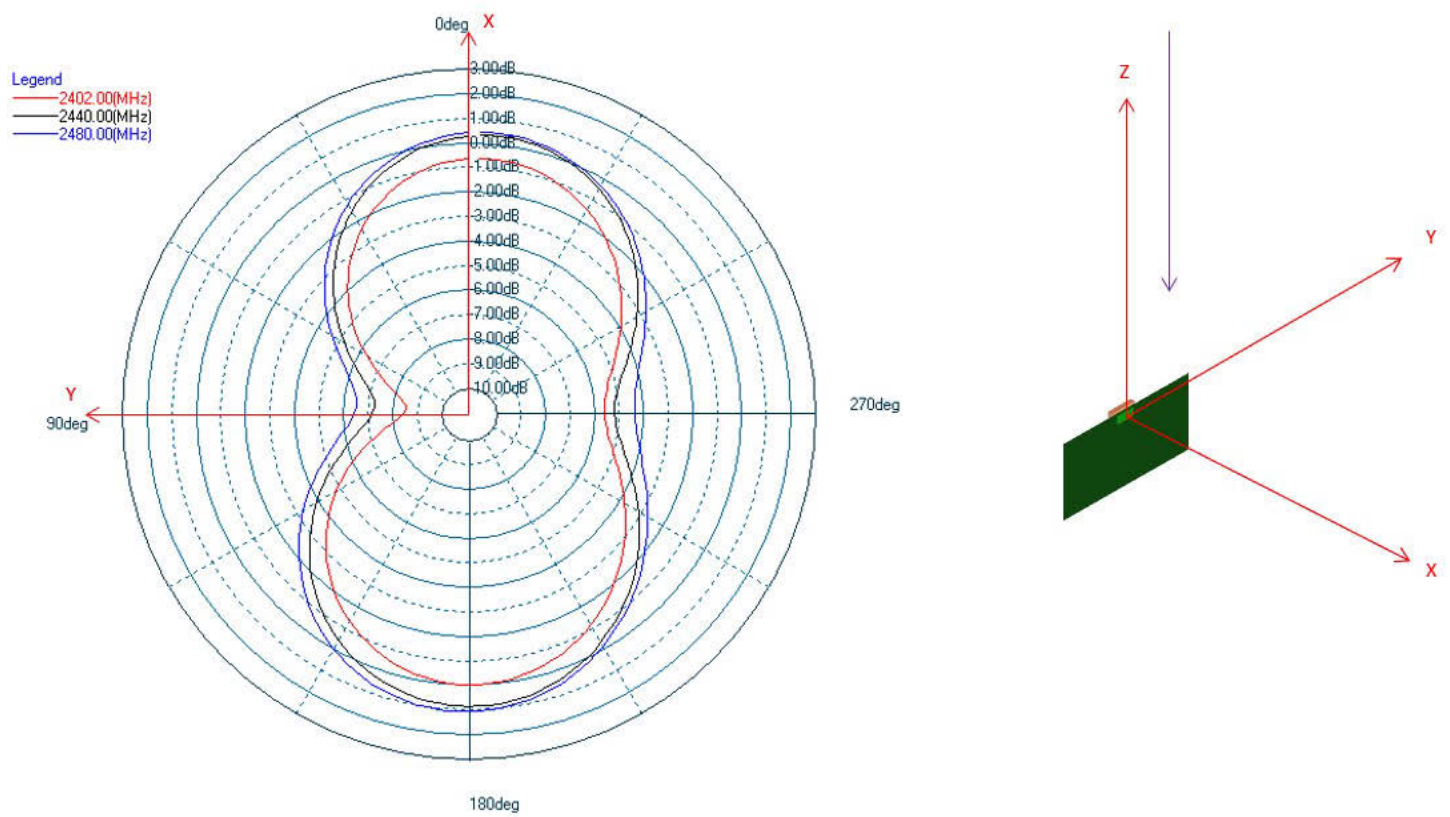

Figure 7.6. Typical 2D Radiation Pattern for BT122, Theta 90

7.3 Measured 3D Radiation Patterns

Typical radiation patterns of the BT122 module. 3D plots are shown below. [Figure 7.8 Typical 3D Radiation Pattern for BT122 on page 19](#) and [Figure 7.8 Typical 3D Radiation Pattern for BT122 on page 19](#) represent radiation patterns from the module on 2440MHz frequency.

3D Gain Patter @ 2440MHz, View 1

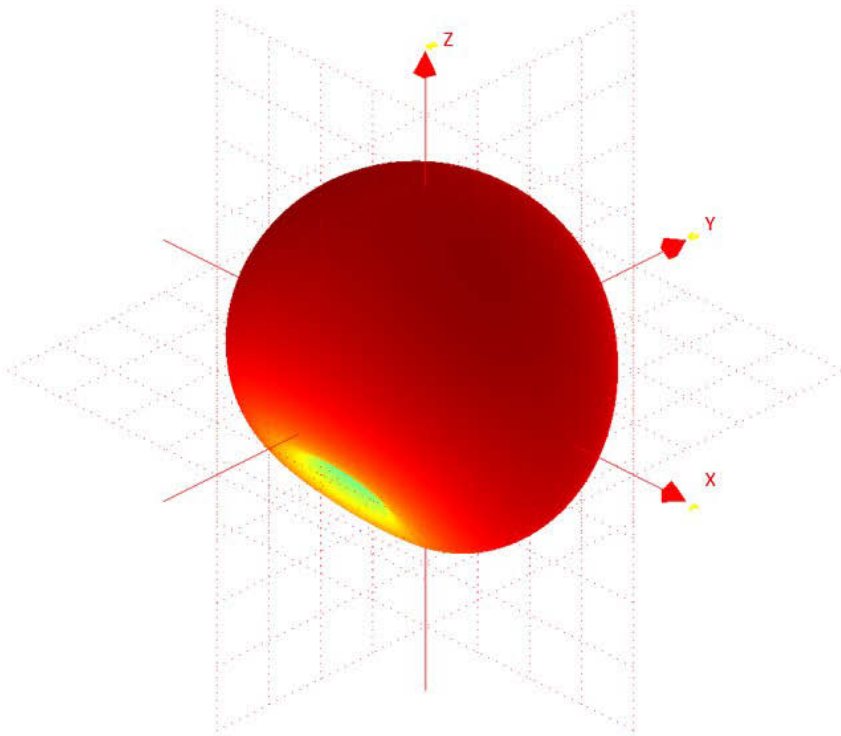
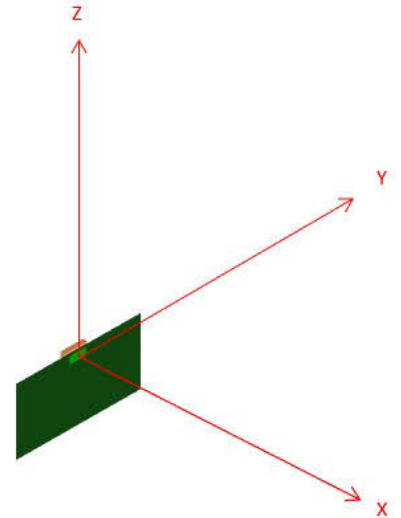

Figure 7.7. Typical 3D Radiation Pattern for BT122



3D Gain Pattern @ 2440MHz, View 2

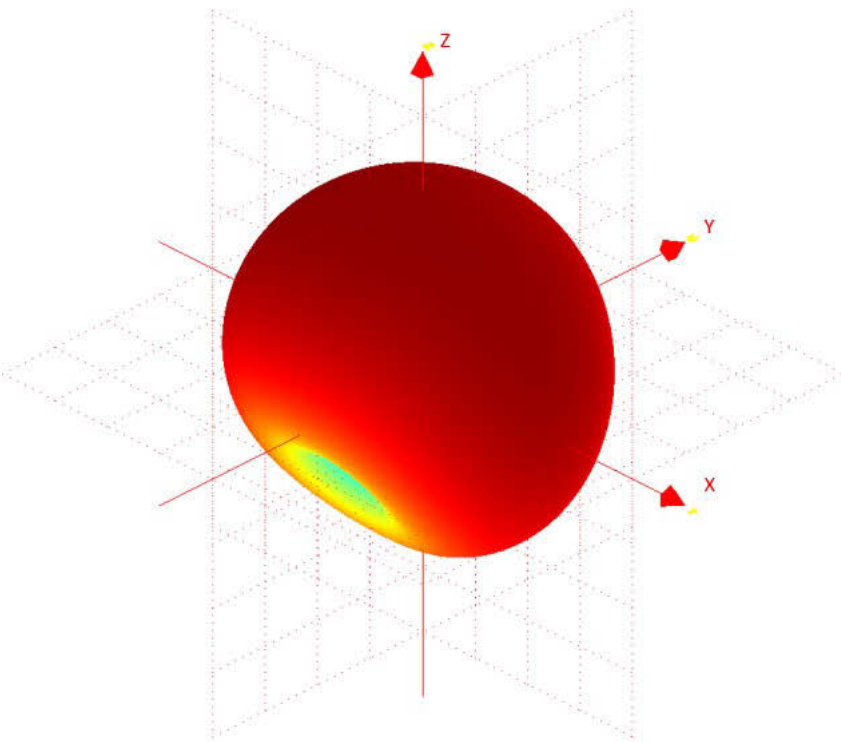
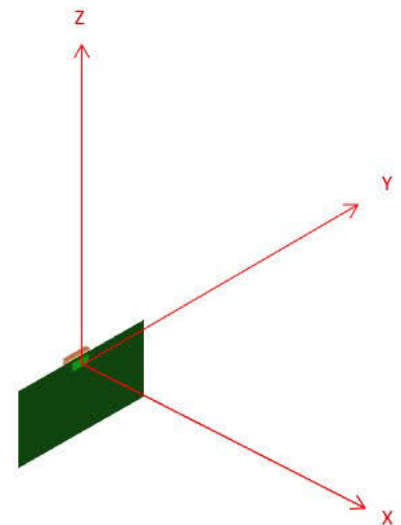

Figure 7.8. Typical 3D Radiation Pattern for BT122



8. Bluetooth® Software Stack

The software implements a full Bluetooth BR/EDR and LE compatible Bluetooth Stack and L2CAP, RFCOMM, SMP, and ATT protocols as well as Bluetooth SPP, HID, Apple iAP2, GATT over BT profiles and any GATT-based Bluetooth Low Energy profile.

The Bluetooth Low Energy Software also is supported by a complete SDK for developing Bluetooth Low Energy applications using either an external host or BGAPI™ serial protocol over UART or fully standalone applications based on a simple scripting language called BGScript™.

Several profiles and software project examples are offered as part of the Bluetooth Low Energy SDK to help expedite the development of Bluetooth Low Energy compatible end-user products.

The main parts of the Bluetooth Low Energy software stack are shown in the figure below.

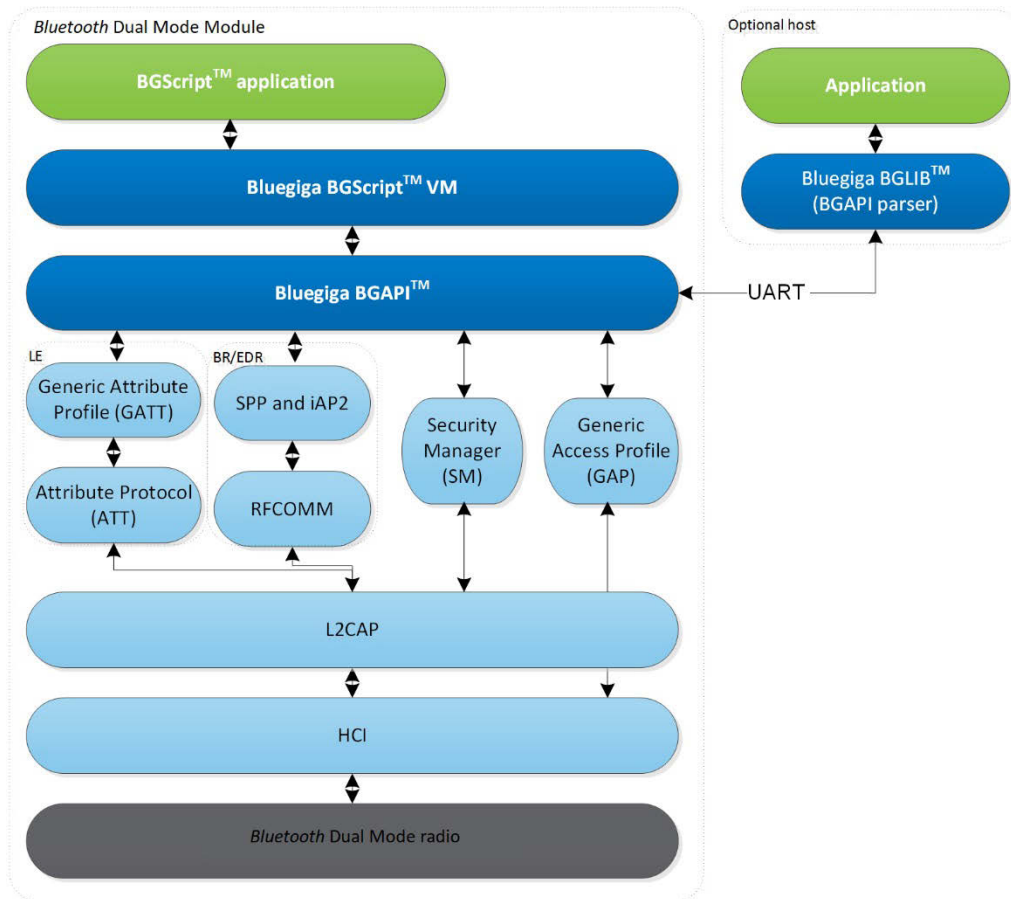

Figure 8.1. Bluetooth Low Energy Software Stack

9. Host Interface

9.1 UART

For applications where an external host (such as an MCU) is used, BT122 can be controlled over the UART interface using the BGA-PI™ serial protocol.

For stable UART communication, it is recommended to use hardware flow control (RTS/CTS pin). It is also recommended that the accuracy of the clock of the controlling host should be 1% or better for the UART signaling to work reliably with speeds exceeding 115200 kbps (maximum baud rate is 3 Mbps).

Default UART settings are listed in the table below.

Table 9.1. BT122 UART Interface Default Settings

Parameter	Default setting
UART baud rate	115200
RTS/CTS flow control	Enabled
Data bits	8
Parity	None
Stop bits	1

10. Connection Examples

The following sections show how to connect the BT122 Dual Mode Module with various external devices using the UART and I²C interface.

10.1 Connecting an External Host Using the UART Interface

The connection to an external host is done using the UART interface of the module. This interface is also used for module reprogramming using the DFU method, and, therefore, an optional connector should be provided on the application PCB to allow reprogramming if needed. A typical solution then is to hold the host in reset state which will keep the UART pins of the host floating, allowing the interface to be used for programming the module by using, for example, a PC and suitable software. See the figure below.

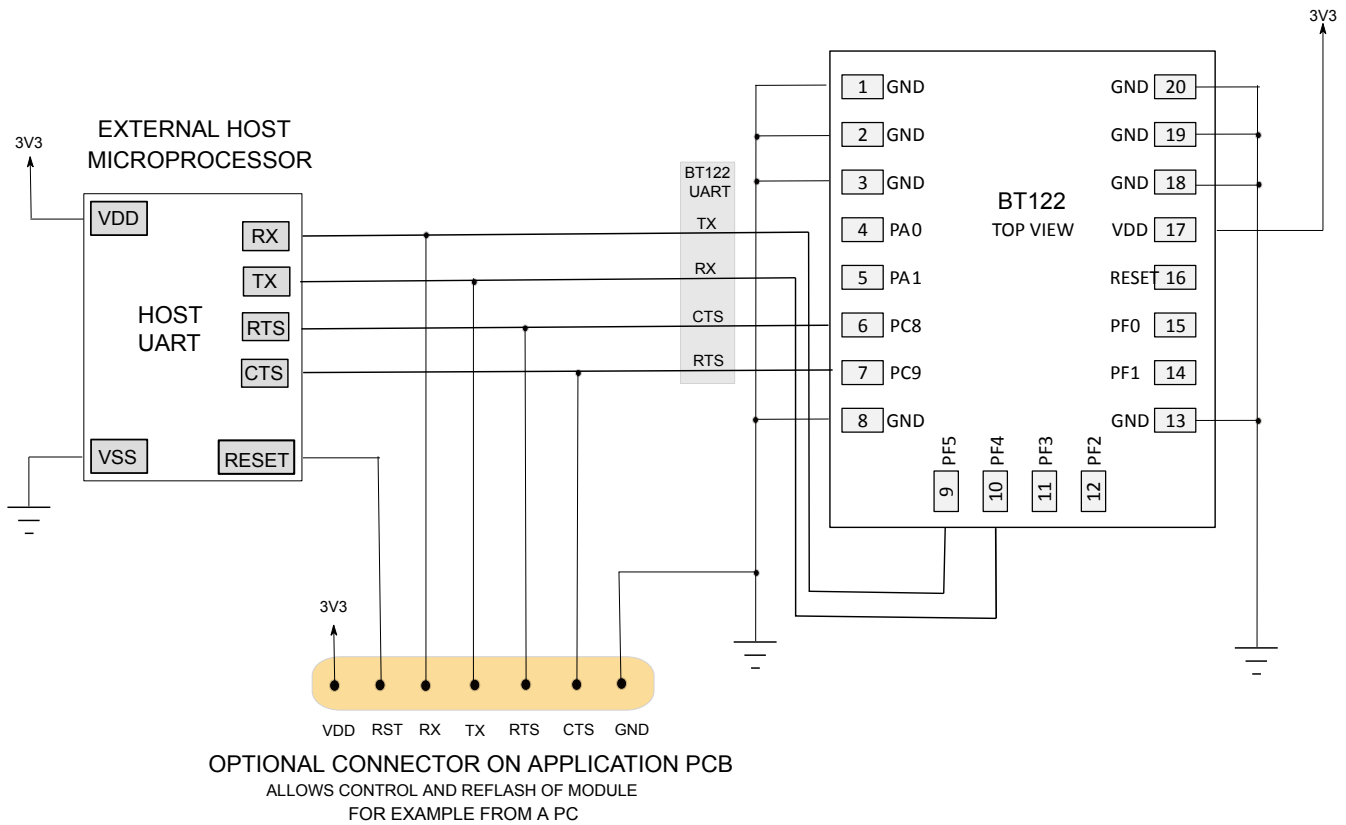

Figure 10.1. Connecting an External Host with BT122 Using UART

10.2 Connecting an External Device Using I²C Interface

The BT122 Dual Mode Module contains one physical I²C peripheral. Pin configurations for the I²C interface are listed in [Table 4.2 General Purpose I/O Pins and Their Functions on page 9](#). An example of this type of interfacing is shown in the figure below. Note the pull-up resistors on the SDA and SCL lines. The example shows the address/chip select lines of the generic peripherals hardwired to VDD, but in practice all or some of them would be wired to GPIO pins of the BT122 configured to work as chip select or address lines controlled by the application hardware. In the example below a generic sensor chip is connected to the BT122 using the I²C.

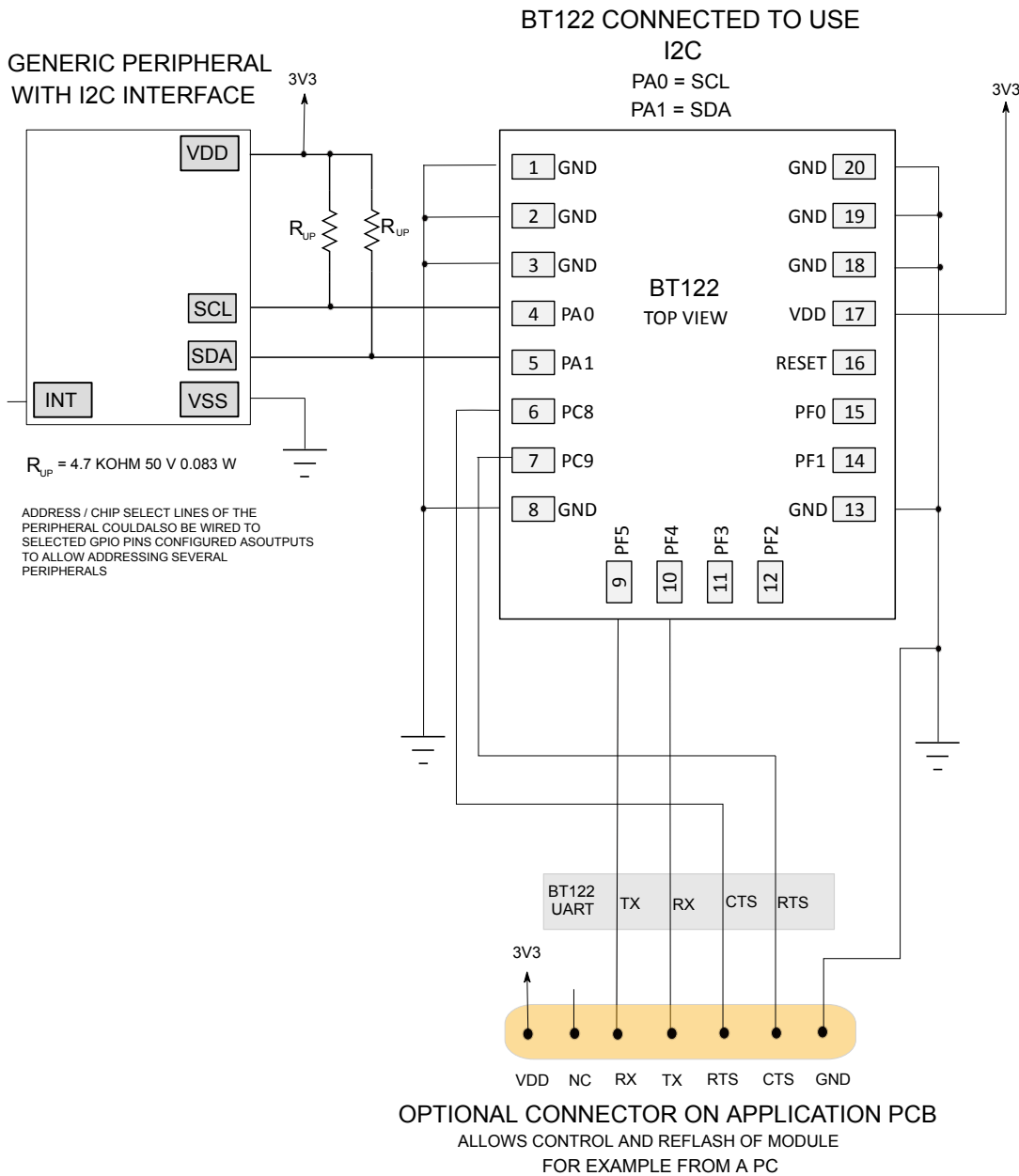

Figure 10.2. Connecting to an I²C Peripheral

11. Electrical Characteristics

11.1 Absolute Maximum Ratings

Table 11.1. Absolute Maximum Ratings

Parameter	Min	Max	Unit
Storage temperature	-40	85	°C
VDD	0	3.6	V
5V tolerant GPIO voltages	-0.3	5.25	V
Other terminal voltages	-0.3	VDD+0.3	V
Output current sourced or sunk by any GPIO pad		50	mA
Current on all GPIO pads combined		200	mA

11.2 Recommended Operating Conditions

Table 11.2. Recommended Operating Conditions

Rating	Min	Max	Unit
Operating temperature range	-40	85	°C
VDD	2.2	3.6	V

11.3 Logic Signal Characteristics

11.3.1 Digital I/O

Table 11.3. Digital I/O Pin Electrical Characteristics

Digital I/O pins	Min	Typ	Max	Unit
Input Voltage Levels				
V _{IL} input logic level low	-	-	0.3 * VDD	V
V _{IH} input logic level high	0.7 * VDD	-	-	V
Output Voltage Levels				
V _{OL} output logic level low	-	-	0.2 * VDD	V
V _{OH} output logic level high	0.8 * VDD	-	-	V

11.3.2 Reset

Table 11.4. Reset Pin Characteristics

Power-on Reset	Min	Typ	Max	Unit
Power-on reset threshold (rising edge)	-	1.2	-	V

11.3.3 ADC

Table 11.5. ADC Pin Characteristics

ADC Characteristics	Min	Typ	Max	Unit
ADC input voltage range	0	-	VDD	V
ADC integral nonlinearity error, end point method, 12-bit	-6	-	6	LSB
ADC offset error	-3	0.25	3	LSB
ADC gain error	-	-0.2	5	%

11.4 Power Consumption

Table 11.6. Typical Power Consumption of Different Operating States

Operation State	Current	Unit	Description
Power Saving Mode 1 - RF idle	6.6	mA	CPU idle RF idle
Power Saving Mode 2 - RF idle	89	μA	CPU sleep RF idle
Reset state	1 - 10	mA	Reset-signal held low
Continuous transmission - BDR	72.6	mA	+11dBm, CPU active
Continuous transmission - EDR	61	mA	+5dBm, CPU active

Table 11.7. Typical Power Consumption, BR/EDR Bluetooth (Master Mode, CPU Sleep Disabled)

Operation State	Current	Unit	Description
Idle, not visible, not connectable	6.4	mA	
Idle, visible, connectable	7.0	mA	
Inquiry	38.3	mA	
Connected, no data	7.4	mA	
Connected, continuous data	12.1	mA	115.2 kbps over BGAPI

Table 11.8. Typical Power Consumptions, BR/EDR Bluetooth (Master Mode, CPU Sleep Enabled)

Operation State	Current	Unit	Description
Idle, visible, connectable	1	μA	
Inquiry	34.5	mA	
Connected, no data	5.7	mA	
Connected, continuous data	13.2	mA	115 kbps over BGAPI ¹

Note:

1. Sleep controlled by wakeup pin. In the constant UART data streaming test, the CPU is not allowed to enter sleep mode.

Table 11.9. Typical Power Consumption, Bluetooth Low Energy (CPU Sleep Enabled)

Advertising Interval	Current	Unit	Description
Advertising, not connectable	2	mA	108 ms
Advertising, connectable	2.3	mA	108 ms
Advertising, not connectable	0.9	μA	1000 ms
Advertising, connectable	1.1	μA	1000 ms

12. RF Characteristics

Table 12.1. Supported Frequencies and Channels

Parameter	Min	Max	Unit
Frequency	2402	2480	MHz
Channels BR/EDR	0	78	CH#
Channels BLE	0	39	CH#

Note: According to the Bluetooth standard, Classic BR/EDR uses frequency hopping across 79 channels, 1 MHz apart. BLE uses frequency hopping across 40 channels, 2 MHz apart.

Table 12.2. Typical Receiver Sensitivity

Packet Type	-40 to 85°C	Unit
DH1	-94	dBm
2DH1	-95	dBm
3DH3	-89.5	dBm
LE	-97	dBm

Table 12.3. Transmitter Output Power at Maximum Setting

Modulation Type	Level	Unit
BR (1 Mbps)	11	dBm
EDR (2, 3 Mbps)	4.9	dBm
LE	7	dBm

Carrier Frequency Accuracy

BT122 fulfills carrier frequency accuracy requirements according the Bluetooth specification.

13. Packaging Specifications

13.1 Dimensions

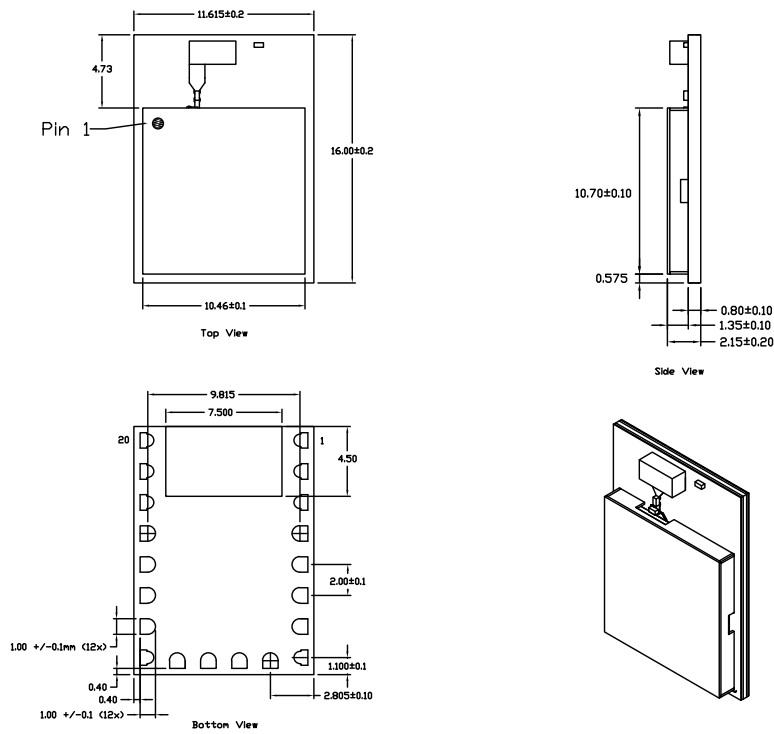

Figure 13.1. BT122 Packaging Specifications

13.2 PCB Landing Pattern

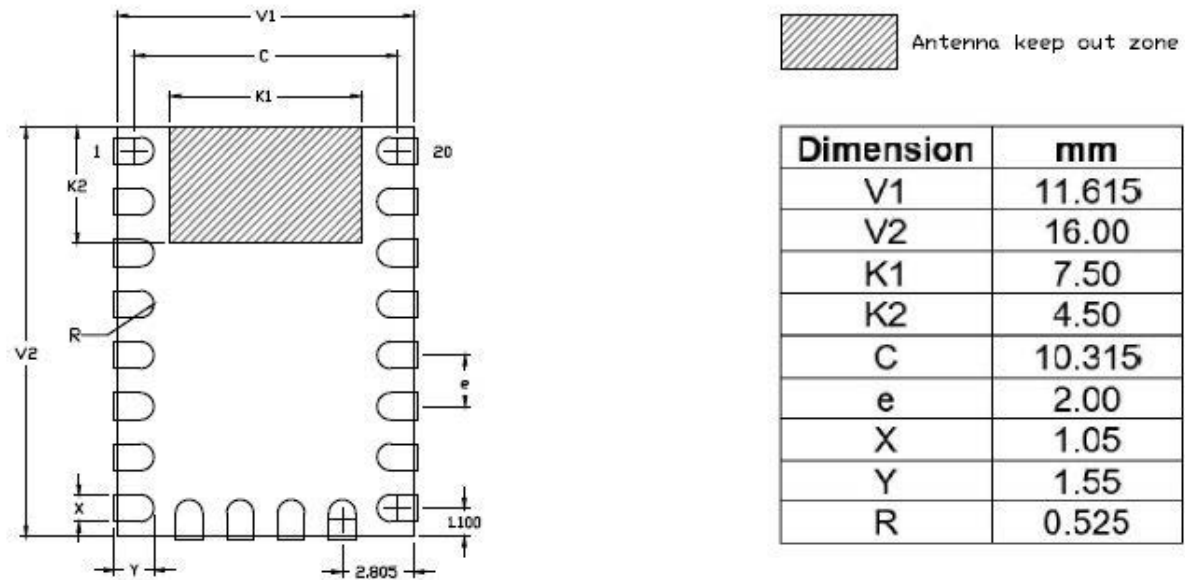

Figure 13.2. BT122 PCB Land Pattern

13.3 Package Marking

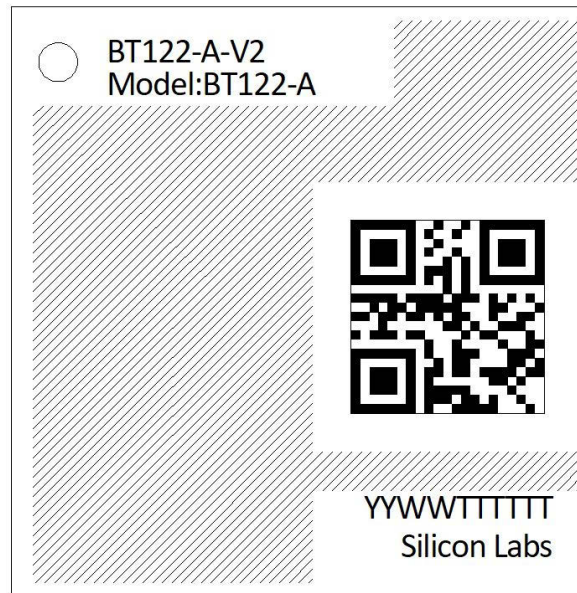

Figure 13.3. BT122 Top Marking

The package marking consists of the following:

- BT122-x-xx - Part number designation
- Model: BT122-x - Model number designation
- QR Code: YYWMMABCDE:
 - YY – Last two digits of the assembly year
 - WW – Two-digit workweek when the device was assembled
 - MMABCDE – Silicon Labs unit code
- YYWWTTTTTT:
 - YY – Last two digits of the assembly year
 - WW – Two-digit workweek when the device was assembled
 - TTTTTT – Manufacturing trace code. The first letter is the device revision.

Note: Certification marks, such as the CE logo, FCC, and IC IDs, etc., will be engraved on the grayed-out area, according to regulatory body requirements.

14. Soldering Recommendations

It is recommended that final PCB assembly of the BT122 follows the industry standard as identified by the Institute for Printed Circuits (IPC). This product is assembled in compliance with the J-STD-001 requirements and the guidelines of IPC-AJ-820. Surface mounting of this product by the end user is recommended to follow IPC-A-610 to meet or exceed class 2 requirements.

CLASS 1 General Electronic Products

Includes products suitable for applications where the major requirement is function of the completed assembly.

CLASS 2 Dedicated Service Electronic Products

Includes products where continued performance and extended life is required, and for which uninterrupted service is desired but not critical. Typically, the end-use environment would not cause failures.

CLASS 3 High Performance/Harsh Environment Electronic Products

Includes products where continued high performance or performance-on-demand is critical, equipment downtime cannot be tolerated, end-use environment may be uncommonly harsh, and the equipment must function when required, such as life support or other critical systems.

15. Tape and Reel Packaging

This section contains information regarding the tape and reel packaging and materials of packaging with dimensions for the Bluetooth Dual Mode BR/EDR and BLE BT122 module.

15.1 Reel Material and Dimensions

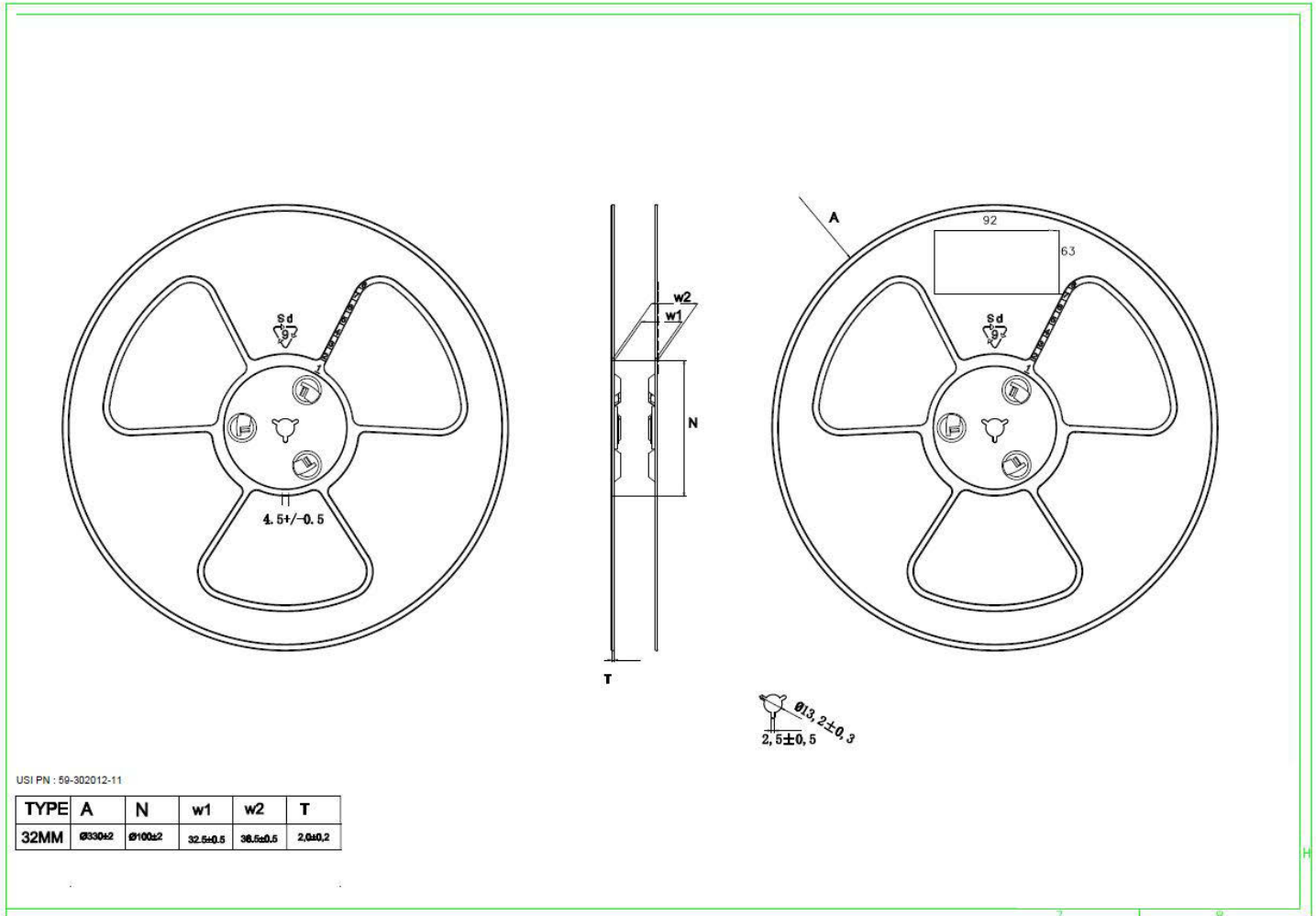

Figure 15.1. Reel Dimensions

15.2 Tape Material and Dimensions

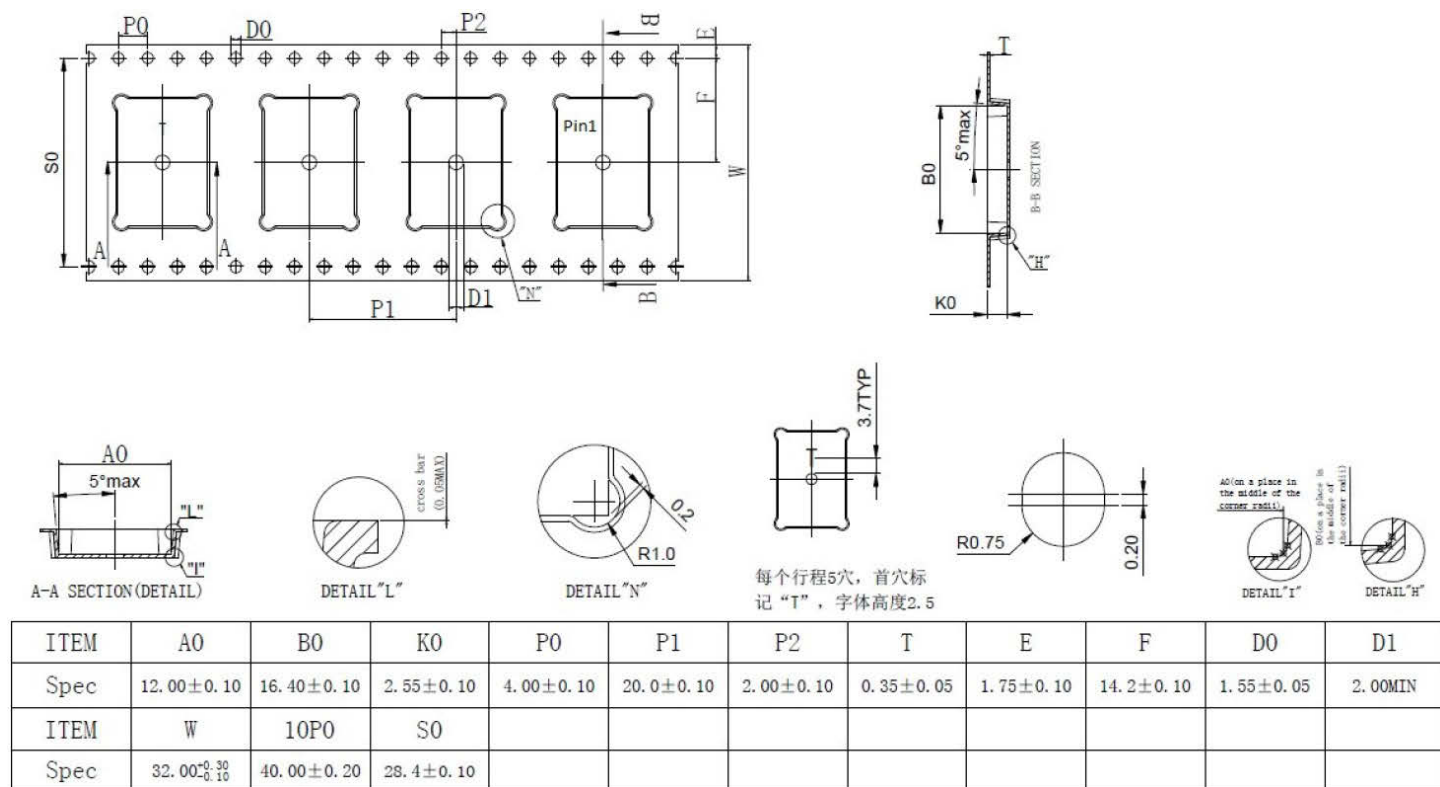

Figure 15.2. Tape Dimensions

16. Certifications

This section details the regulatory certification status of the module in various regions.

The address for the module manufacturer and certification applicant is:

SILICON LABORATORIES FINLAND OY
Alberga Business Park, Bertel Jungin aukio 3,
02600 Espoo, Finland

The BT122 modules have the brand name of "Silicon Labs".

"Silicon Labs" is a trademark globally owned by the Silicon Laboratories Inc corporation, and consequently by the above branch acting as the applicant.

16.1 EU and UK - CE and UKCA

The BT122 modules have been tested against the relevant harmonized/designated standards and are in conformity with the essential requirements and other relevant requirements of the Radio Equipment Directive (RED) (2014/53/EU) and of the Radio Equipment Regulations (RER) (S.I. 2017/1206).

Please notice that every end-product integrating the BT122 module will need to perform the radio EMC tests on the whole assembly, according to the ETSI 301 489-x relevant standard.

It is ultimately the responsibility of the manufacturer to ensure the compliance of the end-product as a whole. The specific product assembly may have an impact to RF radiated characteristics, and manufacturers should carefully consider RF radiated testing with the end-product assembly.

The modules are entitled to carry the CE and UKCA Marks, and a formal Declaration of Conformity (DoC) is available at the product web page which is reachable starting from <https://www.silabs.com/>.

16.2 USA - FCC

This device complies with FCC's e-CFR Title 47, Part 15, Subpart C, Section 15.247 (and related relevant parts of the ANSI C63.10.2013 standard) when operating with the embedded antenna.

Operation is subject to the following two conditions:

1. This device may not cause harmful interference, and
2. This device must accept any interference received, including interference that may cause undesirable operation.

Any changes or modifications not expressly approved by Silicon Labs could void the user's authority to operate the equipment.

FCC RF Radiation Exposure Statement

This equipment complies with FCC radiation exposure limits set forth for an uncontrolled environment. End users must follow the specific operating instructions for satisfying RF exposure compliance.

This transmitter meets the Mobile requirements at a distance of 20 cm and above from the human body, in accordance to the limit(s) exposed in the RF Exposure Analysis.

This transmitter also meets the Portable requirements at distances equal or above those listed for convenience in [Table 16.1 Minimum Separation Distances for SAR Evaluation Exemption on page 37](#).

This transmitter must not be co-located or operating in conjunction with any other antenna or transmitter except in accordance with FCC multi-transmitter product procedures.

OEM Responsibilities to comply with FCC Regulations

This module has been tested for compliance to FCC Part 15.

OEM integrators are responsible for testing their end-product for any additional compliance requirements needed with this module installed (for example, digital device emissions, PC peripheral requirements, etc.).

Additionally, investigative measurements and spot checking are strongly recommended to verify that the full system compliance is maintained when the module is integrated, even with a module having a full modular approval, in accordance to the "Host Product Testing Guidance" in FCC's KDB 996369 D04 Module Integration Guide V01.

- **General Considerations**

This transmitter module is tested as a subsystem and its certification does not cover the FCC Part 15 Subpart B (unintentional radiator) rule requirement, which is applicable to the final host. The final host will need to be assessed for compliance to this portion of rule requirements, if applicable.

- **Manual Information to the End User**

The OEM integrator has to be aware not to provide information to the end-user regarding how to install or remove this RF module, or how to change RF related parameters, in the user's manual of the end-product which integrates this module.

The end user manual shall include all required regulatory information/warnings as shown in this manual.

- **Host Manufacturer Responsibilities**

Host manufacturers are ultimately responsible for the full compliance of the host system.

The final product must be reassessed against all the essential requirements of the FCC rule such as FCC Part 15 Subpart B before it can be placed on the US market. This includes reassessing the transmitter module for compliance with the Radio and EMF essential requirements of the FCC rules. This module must not be incorporated into any other device or system without retesting for compliance as multi-radio and combined equipment

Separation

- To meet the SAR exemption for portable conditions, the minimum separation distance indicated in [Table 16.1 Minimum Separation Distances for SAR Evaluation Exemption on page 37](#) must be maintained between the human body and the radiator (antenna) at all times.
- This transmitter module is tested in a standalone mobile RF exposure condition, and in case of any co-located radio transmitter being allowed to transmit simultaneously, or in case of portable use at closer distances from the human body than those allowing the exceptions rules to be applied, a separate additional SAR evaluation will be required, ultimately leading to a Class II Permissive Change, or more rarely to a new grant.
- **Important Note:** In the event that these conditions cannot be met, then for the FCC authorization to remain valid the final product will have to undergo additional testing to evaluate the RF exposure, and a permissive change will have to be applied. The evaluation (SAR) is in the responsibility of the end-product's manufacturer, as well as the permissive change that can be carried out with the help of the customer's own Telecommunication Certification Body typically acting as the grant holder's agent.

End Product Labeling

The BT122 modules are labeled with their own FCC ID.

In all those cases when the FCC ID is not visible after the module is installed inside another device, then the outside of the device into which the module is installed must also display a label referring to the enclosed module. In that case, the final end-product must be labeled in a visible area with the following:

"Contains Transmitter Module FCC ID: QOQ-BT122"

Or

"Contains FCC ID: QOQ-BT122"

Final note: As long as all the conditions in this and all the above chapters are met, further RF testing of the transmitter will not be strictly required. However, still consider the good practice of ensuring the compliance of the host by spot checking.

Nevertheless, the OEM integrator is still responsible for testing their end-product for any additional compliance requirements which might be mandatory with this module installed.

Class B Device Notice

Note: This equipment has been tested and found to comply with the limits for a Class B digital device, pursuant to part 15 of the FCC Rules. These limits are designed to provide reasonable protection against harmful interference in a residential installation. This equipment generates, uses, and can radiate radio frequency energy and, if not installed and used in accordance with the instructions, may cause harmful interference to radio communications. However, there is no guarantee that interference will not occur in a particular installation. If this equipment does cause harmful interference to radio or television reception, which can be determined by turning the equipment off and on, the user is encouraged to try to correct the interference by one or more of the following measures:

- Reorient or relocate the receiving antenna.
- Increase the separation between the equipment and receiver.
- Connect the equipment into an outlet on a circuit different from that to which the receiver is connected.
- Consult the dealer or an experienced radio / TV technician for help.

16.3 Canada - ISED

ISED

This radio transmitter (IC: 5123A-BT122) has been approved by *Innovation, Science and Economic Development Canada (ISED Canada, formerly Industry Canada)* to operate with the embedded antenna.

This device complies with ISED's license-exempt RSS standards. Operation is subject to the following two conditions:

1. This device may not cause interference; and
2. This device must accept any interference, including interference that may cause undesired operation of the device

RF Exposure Statement

Exception from routine SAR evaluation limits are given in RSS-102 Issue 5.

The module meets the requirements for Mobile use cases when the minimum separation distance from the human body is 20 cm or greater, in accordance to the limit(s) exposed in the RF Exposure Analysis.

For Portable use cases, RF exposure or SAR evaluation is not required when the separation distances from the human body are equal or above those stated in [Table 16.1 Minimum Separation Distances for SAR Evaluation Exemption on page 37](#). If the separation distance from the human body is less than stated in [Table 16.1 Minimum Separation Distances for SAR Evaluation Exemption on page 37](#) the OEM integrator is responsible for evaluating the SAR.

OEM Responsibilities to comply with IC Regulations

The module has been certified for integration into products only by OEM integrators under the following conditions:

- The antenna(s) must be installed such that a minimum separation distance as stated above is maintained between the radiator (antenna) and all persons at all times.
- The transmitter module must not be co-located or operating in conjunction with any other antenna or transmitter.

Important Note: In the event that these conditions cannot be met, the final product will have to undergo additional testing to evaluate the RF exposure in order for the ISED authorization to remain valid, and a permissive change will have to be applied with the help of the customer's own Telecommunication Certification Body typically acting as the certificate holder's agent.

End Product Labeling

The BT122 module is labeled with its own IC ID.

In all those cases when the IC ID is not visible after the module is installed inside another device, then the outside of the device into which the module is installed must also display a label referring to the enclosed module. In that case, the final end product must be labeled in a visible area with the following:

“Contains Transmitter Module IC: 5123A-BT122 ”

or

“Contains IC: 5123A-BT122”

The OEM integrator has to be aware not to provide information to the end user regarding how to install or remove this RF module or change RF related parameters in the user manual of the end product.

As long as all the conditions in this and all the above chapters are met, further transmitter testing will not be required. However, the OEM integrators are still responsible for testing their end-product for any additional compliance requirements required with this module installed (for example, digital device emissions, PC peripheral requirements, etc.).

CAN ICES-003 (B)

This Class B digital apparatus complies with Canadian ICES-003.

ISED (Français)

Le présent émetteur radio (IC: 5123A-BT122) a été approuvé par Innovation, Sciences et Développement Économique Canada (ISED Canada, anciennement Industrie Canada) pour fonctionner avec l'antenne intégrée, avec le gain maximal admissible indiqué. Les types d'antenne non inclus dans cette liste, ayant un gain supérieur au gain maximal indiqué, sont strictement interdits d'utilisation avec cet appareil.

L'émetteur/récepteur exempt de licence contenu dans le présent appareil est conforme aux CNR d'Innovation, Sciences et Développement économique Canada applicables aux appareils radio exempts de licence. L'exploitation est autorisée aux deux conditions suivantes:

1. L'appareil ne doit pas produire de brouillage;
2. L'appareil doit accepter tout brouillage radioélectrique subi, même si le brouillage est susceptible d'en compromettre le fonctionnement.

Déclaration d'exposition RF

Les exceptions aux limites de l'évaluation SAR sont données dans le numéro 5 de la publication RSS-102.

Le module BT122 répond aux exigences pour les cas d'utilisation Mobile lorsque la distance minimale de séparation du corps humain est de 20 cm ou plus, conformément à la (aux) limite(s) exposée(s) dans l'analyse de l'exposition RF.

Pour les cas d'utilisation Portables, l'exposition aux fréquences radio ou l'évaluation du SAR n'est pas nécessaire lorsque les distances de séparation du corps humain sont égales ou supérieures à valeurs indiquées dans le [Table 16.1 Minimum Separation Distances for SAR Evaluation Exemption on page 37](#).

Si la distance de séparation du corps humain est inférieure aux valeurs indiquées ci-dessus, également indiquées dans le tableau 11.2 pour des raisons de commodité, l'intégrateur OEM est responsable de l'évaluation du SAR.

Responsabilités des OEM pour une mise en conformité avec la réglementation IC

Le module a été certifié pour l'intégration dans les produits uniquement par les intégrateurs OEM dans les conditions suivantes:

- L'antenne doit être installée de manière à maintenir une distance de séparation minimale, comme indiqué ci-dessus, entre le radiateur (antenne) et toutes les personnes.
- Le module émetteur ne doit pas être localisé ou fonctionner conjointement avec une autre antenne ou un autre émetteur.

Remarque importante: au cas où ces conditions ne pourraient pas être remplies, le produit final devra être soumis à des tests supplémentaires pour évaluer l'exposition RF, afin que l'autorisation ISED reste valable, et une modification permissive devra être appliquée à l'aide de propre organisme de certification de télécommunication du client en général agissant en tant que titulaire du certificat mandataire.

Étiquetage des produits finis

Les modules BT122 sont étiquetés avec leur propre ID IC.

Dans tous ces cas, si l'ID IC n'est pas visible après l'installation du module à l'intérieur d'un autre appareil, alors l'extérieur de l'appareil dans lequel le module est installé doit également afficher une étiquette faisant référence au module inclus. Dans ce cas, le produit final doit être étiqueté dans une zone visible avec les éléments suivants:

“Contient le module transmetteur IC: 5123A-BT122 ”

or

“Contient IC: 5123A-BT122”

L'intégrateur OEM doit être conscient de ne pas fournir à l'utilisateur final d'informations sur la procédure d'installation ou de retrait de ce module RF ni sur la modification des paramètres liés à la RF dans le manuel d'utilisation du produit final.

Tant que toutes les conditions ci-dessus sont remplies, aucun test supplémentaire de l'émetteur ne sera nécessaire. Toutefois, l'intégrateur OEM reste responsable de l'essai de son produit final pour déterminer les exigences de conformité supplémentaires requises avec ce module installé (par exemple, émissions d'appareils numériques, exigences relatives aux périphériques PC, etc.)

16.4 Proximity to Human Body

When using the module in an application where the radio is located close to the human body, the human RF exposure must be taken into account. FCC, ISED, and CE all have different standards and rules for evaluating the RF exposure. In particular, each regulator has different requirements when it comes to the exemption from having to perform RF exposure and SAR (Specific Absorption Rate) measurements, and the minimum separation distances between the module and human body varies accordingly. The properties of the BT122 allows for the minimum separation distances detailed in the table below for SAR evaluation exemption in portable use cases (less than 20 cm from human body). The module is approved for the Mobile use case (more than 20 cm) without any need for RF Exposure evaluation..

Table 16.1. Minimum Separation Distances for SAR Evaluation Exemption

Certification	BT122-A
FCC	BLE: 0 mm BR/EDR: 5.8 mm
ISED	BLE: 7.9 mm BR/EDR: 16 mm
CE	The RF exposure must always be evaluated using the end-product when transmitting with power levels higher than 20 mW = 13 dBm.

For FCC and ISED, using the module in end-products where the separation distance from the human body is smaller than that listed above is allowed, but requires evaluation of the RF exposure in the final assembly and applying for a *Class 2 Permissive Change* or *Change of ID* to be applied to the existing FCC / ISED approvals of the module. For CE, RF exposure must be evaluated using the end-product in all cases when transmitting at more than the power level indicated in the table.

Note: Placing the module in touch or very close to the human body will have a negative impact on the efficiency of the antenna thus a reduced range is to be expected.

16.5 Japan - MIC

The BT122-A modules are certified in Japan with certification number 209-J00442.

Since September 1, 2014 it is allowed (and highly recommended) that a manufacturer who integrates a radio module in their host equipment places the certification mark and certification number on the outside of the host equipment. This combination of mark and number, and their relative placement, is depicted in figure [Figure 16.1 GITEKI Mark and ID on page 38](#), and depending on the size of the module it might also appear on the top shield markings of the radio module. The certification mark and certification number must be placed close to the text in the Japanese language which is provided below. This change in the Radio Law has been made in order to enable users of the combination of host and radio module to verify if they are actually using a radio device which is approved for use in Japan

Certification Text to be Placed on the Outside Surface of the Host Equipment:

当該機器には電波法に基づく、技術基準適合証明等を受けた特定無線設備を装着している。

Translation of the text:

“This equipment contains specified radio equipment that has been certified to the Technical Regulation Conformity Certification under the Radio Law.”

The "Giteki" mark shown in the following figures must be affixed to an easily noticeable section of the specified radio-enabled host equipment. Notice that such section may be required to contain additional information if the end-device embedding the module is also subject to a telecom approval.

The manufacturer of the final product is also responsible to provide a Japanese language version of the User Manual and/or Installation Instructions as a companion document coming with the final product when placed on the market in Japan.



Figure 16.1. GITEKI Mark and ID

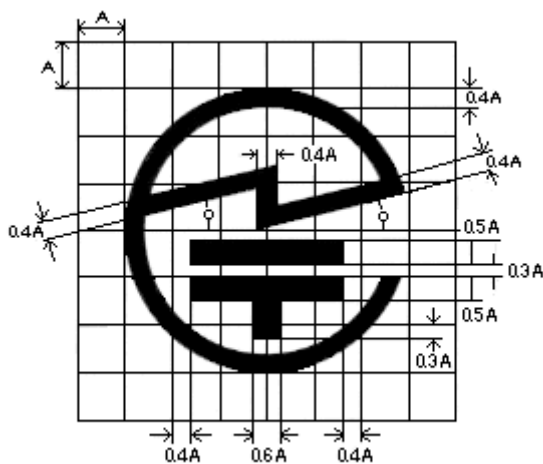

Figure 16.2. GITEKI Mark

16.6 South Korea - KC

The BT122 modules have a RF registration for import and use in South-Korea.

Registration number is: R-R-BGT-BT122

The RF-certified module is meant to be integrated into an end-product, which is then exempted from doing the RF emission testing, as long as the recommended design guidance is followed.

EMC testing and any other relevant test applicable to the end-product, plus appropriate labeling of the end-product, might still be required for the full regulatory compliance.

16.7 China - SRRC

The BT122-A modules have a full modular approval for re-use by the OEM integrators.

The SRRC certificate number is 2021-8225 and modules are labeled with CMIIT ID: 2021DJ8225

Note: Every end-product integrating the module must be labeled with the following statement, or alternatively the statement will have to go to the end-product's user manual:

本设备包含型号核准代码为：CMIIT ID：2021DJ8225的无线电发射模块

(Translation: This equipment contains a radio transmitter module with model approval code: CMIIT ID: 2021DJ8225)

16.8 Bluetooth Qualification

The BT122 modules come with a SIG End-product Qualification based on the Core Spec v5.1 and having Declaration ID of D055460 and QDID of 169960, with a listing date of 20 July 2021.

17. Ordering Guide

Ordering Code	Description	Packaging
BT122-A-V2	BT122 Bluetooth dual mode BR/EDR - BLE module with an integrated antenna.	Cut tape
BT122-A-V2R	BT122 Bluetooth dual mode BR/EDR - BLE module with an integrated antenna.	Reel

Note: Throughout this document, the devices in the table above may be referred to by their product family name (BT122), model name (BT122-A), or full ordering code.

18. Revision History

Revision 1.0

August 2021

- Updated [Table 11.4 Reset Pin Characteristics on page 25](#)
- Updated [Figure 13.1 BT122 Packaging Specifications on page 28](#) and [Figure 13.2 BT122 PCB Land Pattern on page 28](#)

Revision 0.6

June 2021

- Updated [Table 16.1 Minimum Separation Distances for SAR Evaluation Exemption on page 37](#)
- Updated China - SRRC

Revision 0.51

June 2021

- Updated Feature List: EDR updated to +5dBm
- Updated ISED French text
- Added Declaration ID, Qualification Design ID, and listing date in [Section 16.8 Bluetooth Qualification](#)
- Updated text and Figure cross-reference in [Section 16.5 Japan - MIC](#)

Revision 0.5

June 2021

- Updated documentation for Certification

Revision 0.1

March 2021

- Initial Draft

Smart. Connected. Energy-Friendly.

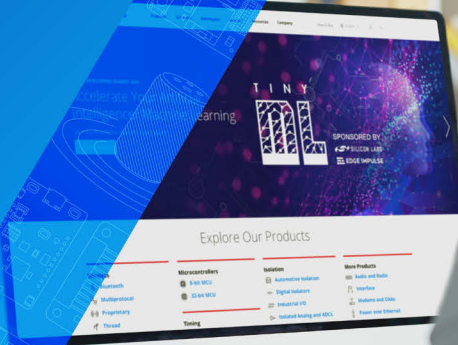

IoT Portfolio
www.silabs.com/products



Quality
www.silabs.com/quality



Support & Community
www.silabs.com/community

Disclaimer

Silicon Labs intends to provide customers with the latest, accurate, and in-depth documentation of all peripherals and modules available for system and software implementers using or intending to use the Silicon Labs products. Characterization data, available modules and peripherals, memory sizes and memory addresses refer to each specific device, and “Typical” parameters provided can and do vary in different applications. Application examples described herein are for illustrative purposes only. Silicon Labs reserves the right to make changes without further notice to the product information, specifications, and descriptions herein, and does not give warranties as to the accuracy or completeness of the included information. Without prior notification, Silicon Labs may update product firmware during the manufacturing process for security or reliability reasons. Such changes will not alter the specifications or the performance of the product. Silicon Labs shall have no liability for the consequences of use of the information supplied in this document. This document does not imply or expressly grant any license to design or fabricate any integrated circuits. The products are not designed or authorized to be used within any FDA Class III devices, applications for which FDA premarket approval is required or Life Support Systems without the specific written consent of Silicon Labs. A “Life Support System” is any product or system intended to support or sustain life and/or health, which, if it fails, can be reasonably expected to result in significant personal injury or death. Silicon Labs products are not designed or authorized for military applications. Silicon Labs products shall under no circumstances be used in weapons of mass destruction including (but not limited to) nuclear, biological or chemical weapons, or missiles capable of delivering such weapons. Silicon Labs disclaims all express and implied warranties and shall not be responsible or liable for any injuries or damages related to use of a Silicon Labs product in such unauthorized applications.

Note: This content may contain offensive terminology that is now obsolete. Silicon Labs is replacing these terms with inclusive language wherever possible. For more information, visit www.silabs.com/about-us/inclusive-lexicon-project

Trademark Information

Silicon Laboratories Inc.®, Silicon Laboratories®, Silicon Labs®, SiLabs® and the Silicon Labs logo®, Bluegiga®, Bluegiga Logo®, EFM®, EFM32®, EFR, Ember®, Energy Micro, Energy Micro logo and combinations thereof, “the world’s most energy friendly microcontrollers”, Redpine Signals®, WiSeConnect®, n-Link, ThreadArch®, EZLink®, EZRadio®, EZRadioPRO®, Gecko®, Gecko OS, Gecko OS Studio, Precision32®, Simplicity Studio®, Telegesis, the Telegesis Logo®, USBXpress®, Zentri, the Zentri logo and Zentri DMS, Z-Wave®, and others are trademarks or registered trademarks of Silicon Labs. ARM, CORTEX, Cortex-M3 and THUMB are trademarks or registered trademarks of ARM Holdings. Keil is a registered trademark of ARM Limited. Wi-Fi is a registered trademark of the Wi-Fi Alliance. All other products or brand names mentioned herein are trademarks of their respective holders.



Silicon Laboratories Inc.
400 West Cesar Chavez
Austin, TX 78701
USA

www.silabs.com