

bq27z561 Impedance Track™ Battery Gas Gauge Solution for 1-Series Cell Li-Ion Battery Packs

1 Features

- Supports Current Sense Resistors Down to 1 mΩ
- SHA-256 Authentication Responder for Increased Battery Pack Security
- Two Independent ADCs
 - Support for Simultaneous Current and Voltage Sampling
 - High-Accuracy Coulomb Counter with Input Offset Error < 1 μV (Typical)
- Low-Voltage (2 V) Operation
- Supports Pack-Side Gauging
- Wide-Range Current Applications (1 mA to > 5 A)
- Active High or Low Interrupt Pin
- Reduced Power Modes (Typical Battery Pack Operating Range Conditions)
 - Typical SLEEP Mode: < 11 μA
 - Typical DEEP SLEEP Mode: < 9 μA
 - Typical OFF Mode: < 1.9 μA
- Internal and External Temperature Sense Functions
- 400-kHz I²C Bus Communications Interface for High-Speed Programming and Data Access
- HDQ One-Wire for Communication with Host
- Compact 12-Pin DSBGA Package (YPH)

2 Applications

- Smart Phones
- Digital Still and Video Cameras
- Tablet Computing
- Portable and Wearable Health Devices and Portable Audio Devices

3 Description

The Texas Instruments bq27z561 Impedance Track™ gas gauge solution is a highly integrated, accurate 1-series cell gas gauge with a flash programmable custom reduced instruction-set CPU (RISC) and SHA-256 authentication for Li-Ion and Li-Polymer battery packs. The 1-series cell capability includes parallel cells for increased capacity.

The bq27z561 gas gauge communicates via I²C-compatible and HDQ one-wire interfaces and includes several key features that can help facilitate accurate gas gauging applications. Integrated temperature sense functions (internal and external options) enable system and battery temperature measurements. The integrated SHA-256 functionality helps enable secure identification between systems and packs. The interrupt function facilitates the bq27z561 device to inform the system when a state-of-charge (SOC), voltage, or temperature fault occurs. The low-voltage operation enables the system to continue monitoring the battery even in deeply discharged conditions. During low-activity situations, the device can be set to the low power coulomb counting (CC) mode, which allows the device to continue its coulomb counting while reducing operating current significantly.

Device Information⁽¹⁾

PART NUMBER	PACKAGE	BODY SIZE (NOM)
bq27z561	DSBGA (12)	1.72 mm x 2.09 mm

(1) For all available packages, see the orderable addendum at the end of the data sheet.

Simplified Schematic

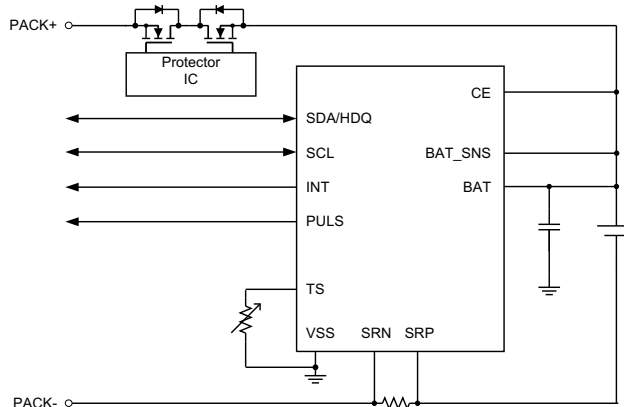

Table of Contents

1 Features	1	6.18 I ² C Timing — 400 kHz	7
2 Applications	1	6.19 HDQ Timing	8
3 Description	1	6.20 Typical Characteristics	10
4 Revision History	2	7 Detailed Description	10
5 Pin Configuration and Functions	3	7.1 Overview	10
6 Specifications	4	7.2 Functional Block Diagram	11
6.1 Absolute Maximum Ratings	4	7.3 Feature Description	11
6.2 ESD Ratings	4	7.4 Device Functional Modes	13
6.3 Recommended Operating Conditions	4	8 Applications and Implementation	14
6.4 Thermal Information	4	8.1 Application Information	15
6.5 Supply Current	5	8.2 Typical Applications	15
6.6 Internal 1.8-V LDO (REG18)	5	9 Power Supply Requirements	17
6.7 I/O (CE, PULS, INT)	5	10 Layout	17
6.8 Internal Temperature Sensor	5	10.1 Layout Guidelines	17
6.9 NTC Thermistor Measurement Support	5	10.2 Layout Example	18
6.10 Coulomb Counter (CC)	5	11 Device and Documentation Support	19
6.11 Analog Digital Converter (ADC)	6	11.1 Documentation Support	19
6.12 Internal Oscillator Specifications	6	11.2 Receiving Notification of Documentation Updates	19
6.13 Voltage Reference1 (REF1)	6	11.3 Community Resources	19
6.14 Voltage Reference2 (REF2)	7	11.4 Trademarks	19
6.15 Flash Memory	7	11.5 Electrostatic Discharge Caution	19
6.16 I ² C I/O	7	11.6 Glossary	19
6.17 I ² C Timing — 100 kHz	7	12 Mechanical, Packaging, Orderable Information	19

4 Revision History

DATE	REVISION	NOTES
June 2018	A	Initial Release

5 Pin Configuration and Functions

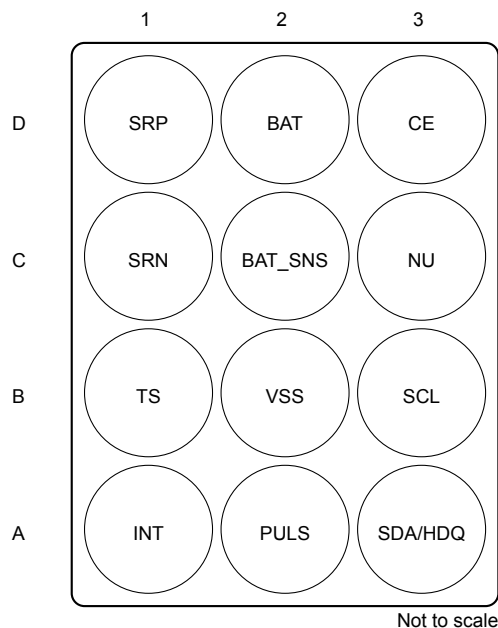

Pin Functions

NUMBER	NAME	I/O	DESCRIPTION
D2	BAT	P ⁽¹⁾	Battery voltage measurement input. Kelvin battery sense connection to BAT_SNS. Connect a capacitor (1 μ F) between BAT and VSS. Place the capacitor close to the gauge.
D3	CE	I	Active high chip enable
C2	BAT_SNS	AI	Battery sense
A1	INT	O	Interrupt for voltage, temperature, and state of charge (programmable active high or low)
A2	PULS	O	Programmable pulse width with active high or low option
B1	TS	AI	Temperature input for ADC
C3	NU	NU	Makes no external connection
B3	SCL	I/O	Serial clock for I ² C interface; requires external pull up when used. It can be left floating if unused.
A3	SDA/HDQ	I/O	Serial data for I ² C interface and one-wire interface for HDQ (selectable); requires external pull up when used. It can be left floating if unused.
D1	SRP	I	Analog input pin connected to the internal coulomb counter peripheral for integrating a small voltage between SRP (positive side) and SRN
C1	SRN	I	Analog input pin connected to the internal coulomb counter peripheral for integrating a small voltage between SRP (positive side) and SRN.
B2	VSS	P	Device Ground

(1) P = Power Connection, O = Digital Output, AI = Analog Input, I = Digital Input, I/O = Digital Input/Output, NU = Not Used

6 Specifications

6.1 Absolute Maximum Ratings

Over operating free-air temperature range (unless otherwise noted)⁽¹⁾

		MIN	MAX	UNIT
Input Voltage	BAT	-0.3	6	V
	INT, PULS, CE	-0.3	6	V
	SRP, SRN, BAT_SNS	-0.3	$V_{BAT} + 0.3$	V
	TS	-0.3	2.1	V
	SCL, SDA/HDQ	-0.3	6	V
Operating ambient temperature, T_A		-40	85	°C
Operating junction temperature, T_J		-40	125	°C
Storage temperature, T_{stg}		-65	150	°C

- (1) Stresses beyond those listed under *Absolute Maximum Ratings* may cause permanent damage to the device. These are stress ratings only, which do not imply functional operation of the device at these or any other conditions beyond those indicated under *Recommended Operating Conditions*. Exposure to absolute-maximum-rated conditions for extended periods may affect device reliability.

6.2 ESD Ratings

		VALUE	UNIT
$V_{(ESD)}$ Electrostatic discharge	Human-body model (HBM) on all pins, per ANSI/ESDA/JEDEC JS-001 ⁽¹⁾	±1500	V
	Charged-device model (CDM) on all pins, per JEDEC specification JESD22-C101 ⁽²⁾	±500	

- (1) JEDEC document JEP155 states that 500-V HBM allows safe manufacturing with a standard ESD control process.
 (2) JEDEC document JEP157 states that 250-V CDM allows safe manufacturing with a standard ESD control process.

6.3 Recommended Operating Conditions

Unless otherwise noted, characteristics noted under conditions of $T_A = -40$ to 85°C

		MIN	NOM	MAX	UNIT	
V_{BAT}	Supply voltage	No operating restrictions		2.0	5.5	V
C_{BAT}	External capacitor from BAT to VSS			1		µF
V_{TS}	Temperature sense			0	1.8	V
$V_{PULS}, V_{INT}, V_{CE}$	Input and output pins			0	V_{BAT}	V
$V_{SCL}, V_{SDA/HDQ}$	Communication pins			0	V_{BAT}	V

6.4 Thermal Information

Over-operating free-air temperature range (unless otherwise noted)

THERMAL METRIC ⁽¹⁾		bq27z561		UNIT
		DSBGA (YPH)		
		(12 PINS)		
$R_{\theta JA}$	Junction-to-ambient thermal resistance	64.1		°C/W
$R_{\theta JC(top)}$	Junction-to-case (top) thermal resistance	59.8		
$R_{\theta JB}$	Junction-to-board thermal resistance	52.7		
Ψ_{JT}	Junction-to-top characterization parameter	0.3		
Ψ_{JB}	Junction-to-board characterization parameter	28.3		
$R_{\theta JC(bot)}$	Junction-to-case (bottom) thermal resistance	2.4		

- (1) For more information about traditional and new thermal metrics, see the Semiconductor and IC Package Thermal Metrics application report ([SPRA953](#)).

6.5 Supply Current

Unless otherwise noted, characteristics noted under conditions of $T_A = -40$ to 85°C

PARAMETER	TEST CONDITIONS	MIN	TYP	MAX	UNIT
I_{NORMAL}	Standard operating Conditions		60		μA
I_{SLEEP}	Sense resistor current below Sleep mode threshold		11		μA
$I_{\text{DEEPSLEEP}}$	Sense resistor current below Deep Sleep mode threshold		9		μA
I_{OFF}	$\text{CE} = V_{\text{IL}}$		0.5		μA

6.6 Internal 1.8-V LDO (REG18)

Unless otherwise noted, characteristics noted under conditions of $T_A = -40$ to 85°C

PARAMETER	TEST CONDITIONS	MIN	TYP	MAX	UNIT
V_{REG18}	Regulator output voltage	1.6	1.8	2.0	V
V_{PORth}	POR threshold	Rising Threshold		1.7	V
V_{PORhy}	POR hysteresis		0.1		V

6.7 I/O (CE, PULS, INT)

Unless otherwise noted, characteristics noted under conditions of $T_A = -40$ to 85°C

PARAMETER	TEST CONDITIONS	MIN	TYP	MAX	UNIT
V_{IH}	High-level input voltage	$V_{\text{REG18}} = 1.8\text{ V}$			V
V_{IL}	Low-level input voltage low	$V_{\text{REG18}} = 1.8\text{ V}$		0.50	V
V_{OL}	Output voltage low for INT/PULS	$V_{\text{REG18}} = 1.8\text{ V}$, $I_{\text{OL}} = 1\text{ mA}$		0.4	V
C_1	Input capacitance		5		pF
I_{Ikg}	Input leakage current			1	μA

6.8 Internal Temperature Sensor

Unless otherwise noted, characteristics noted under conditions of $T_A = -40$ to 85°C

PARAMETER	TEST CONDITIONS	MIN	TYP	MAX	UNIT	
$V_{\text{(TEMP)}}$	Internal Temperature sensor voltage drift	V_{TEMP}	1.65	1.73	1.8	mV/ $^\circ\text{C}$
		$V_{\text{TEMP}} - V_{\text{TEMPN}}$ (assured by design)	0.17	0.18	0.19	

6.9 NTC Thermistor Measurement Support

Unless otherwise noted, characteristics noted under conditions of $T_A = -40$ to 85°C

PARAMETER	TEST CONDITIONS	MIN	TYP	MAX	UNIT
$R_{\text{NTRC(PU)}}$	Internal Pullup Resistance	14.4	18	21.6	k Ω
$R_{\text{NTC(DRIFT)}}$	Resistance drift over temperature	-250	-120	0	PPM/ $^\circ\text{C}$

6.10 Coulomb Counter (CC)

Unless otherwise noted, characteristics noted under conditions of $T_A = -40$ to 85°C

PARAMETER	TEST CONDITIONS	MIN	TYP	MAX	UNIT	
$V_{\text{(CC_IN)}}$	Input voltage range	-0.1		0.1	V	
$t_{\text{(CC_CONV)}}$	Conversion time		1000		ms	
	Effective Resolution		1 LSB		μV	
	Integral nonlinearity	16-bit, Best fit over input voltage range	-22.3	5.2	+22.3	LSB
	Differential nonlinearity	16-bit, No missing codes		1.5		LSB
	Offset error	16-bit Post-Calibration	-2.6	1.3	+2.6	LSB
	Offset error drift	15-bit + sign, Post Calibration		0.04	0.07	LSB/ $^\circ\text{C}$
	Gain Error	15-bit + sign, Over input voltage range	-492	131	+492	LSB

Coulomb Counter (CC) (continued)

Unless otherwise noted, characteristics noted under conditions of $T_A = -40$ to 85°C

PARAMETER	TEST CONDITIONS	MIN	TYP	MAX	UNIT
Gain Error drift	15-bit + sign, Over input voltage range		4.3	9.8	LSB/ $^\circ\text{C}$
Effective input resistance		7			$\text{M}\Omega$

6.11 Analog Digital Converter (ADC)

Unless otherwise noted, characteristics noted under conditions of $T_A = -40$ to 85°C

PARAMETER	TEST CONDITIONS	MIN	TYP	MAX	UNIT
$V_{\text{ADC_TS_GPIO}}$ Input voltage range	$V_{\text{FS}} = V_{\text{REF2}}$	-0.2		1.0	V
	$V_{\text{FS}} = V_{\text{REG18}} * 2$	-0.2		1.44	V
$V_{\text{BAT_MODE}}$ Battery Input Voltage		-0.2		5.5	V
Integral nonlinearity	16-bit, Best fit, -0.1 V to $0.8 * V_{\text{REF2}}$	-8.4		+8.4	LSB
Differential nonlinearity	16-bit, No missing codes		1.5		LSB
Offset error	16-bit Post-Calibration ⁽¹⁾ , $V_{\text{FS}} = V_{\text{REF2}}$	-4.2	1.8	+4.2	LSB
Offset error drift	16-bit Post-Calibration ⁽¹⁾ , $V_{\text{FS}} = V_{\text{REF2}}$		0.02	0.1	LSB/ $^\circ\text{C}$
Gain Error	16-bit, -0.1 to $0.8 * V_{\text{FS}}$	-492	131	+492	LSB
Gain Error drift	16-bit, -0.1 to $0.8 * V_{\text{FS}}$		2	4.5	LSB/ $^\circ\text{C}$
Effective input resistance		8			$\text{M}\Omega$
$t_{(\text{ADC_CONV})}$ Conversion time			11.7		ms
Effective resolution		14	15		bits

(1) Factory calibration.

6.12 Internal Oscillator Specifications

Unless otherwise noted, characteristics noted under conditions of $T_A = -40$ to 85°C

PARAMETER	TEST CONDITIONS	MIN	TYP	MAX	UNIT
High Frequency Oscillator (HFO)					
f_{HFO} Operating frequency			16.78		MHz
f_{HFO} HFO frequency drift	$T_A = -20^\circ\text{C}$ to 70°C	-2.5%		2.5%	
	$T_A = -40^\circ\text{C}$ to 85°C	-3.5		3.5	
t_{HFOSTART} HFO Start-up time	$T_A = -40^\circ\text{C}$ to 85°C , oscillator frequency within +/- 3% of nominal frequency or a power-on reset			4	ms
Low Frequency Oscillator (LFO)					
f_{LFO} Operating frequency			65.536		kHz
$f_{\text{LFO(ERR)}}$ Frequency error	$T_A = -40^\circ\text{C}$ to 85°C	-2.5%		+2.5%	

6.13 Voltage Reference1 (REF1)

Unless otherwise noted, characteristics noted under conditions of $T_A = -40$ to 85°C

PARAMETER	TEST CONDITIONS	MIN	TYP	MAX	UNIT
V_{REF1} Internal Reference Voltage ⁽¹⁾		1.195	1.21	1.227	V
$V_{\text{REF1_DRIFT}}$ Internal Reference Voltage Drift	$T_A = -40^\circ\text{C}$ to 85°C	-80		+80	PPM/ $^\circ\text{C}$

(1) Used for CC and LDO

6.14 Voltage Reference2 (REF2)

Unless otherwise noted, characteristics noted under conditions of $T_A = -40$ to 85°C

PARAMETER	TEST CONDITIONS	MIN	TYP	MAX	UNIT
V_{REF2}	Internal Reference Voltage ⁽¹⁾	1.2	1.21	1.22	V
V_{REF2_DRIFT}	Internal Reference Voltage Drift	$T_A = -40^\circ\text{C}$ to 85°C		20	PPM/ $^\circ\text{C}$

(1) Used for ADC

6.15 Flash Memory

Unless otherwise noted, characteristics noted under conditions of $T_A = -40$ to 85°C

PARAMETER	TEST CONDITIONS	MIN	TYP	MAX	UNIT
Data retention		10	100		Years
Flash programming write cycles	Data Flash	20000			Cycles
	Instruction Flash	1000			Cycles
$t_{(ROWPROG)}$	Row programming time			40	μs
$t_{(MASSERASE)}$	Mass-erase time	$T_A = -40^\circ\text{C}$ to 85°C		40	ms
$t_{(PAGEERASE)}$	Page-erase time	$T_A = -40^\circ\text{C}$ to 85°C		40	ms
$I_{FLASHREAD}$	Flash Read Current	$T_A = -40^\circ\text{C}$ to 85°C		1	mA
$I_{FLASHWRITE}$	Flash Write Current	$T_A = -40^\circ\text{C}$ to 85°C		5	mA
$I_{FLASHERASE}$	Flash Erase Current	$T_A = -40^\circ\text{C}$ to 85°C		15	mA

6.16 I²C I/O

Unless otherwise noted, characteristics noted under conditions of $T_A = -40$ to 85°C

PARAMETER	TEST CONDITIONS	MIN	TYP	MAX	UNIT
V_{IH}	High-level input voltage	SCL, SDA/HDQ, $V_{REG18} = 1.8\text{ V}$		1.26	V
V_{IL}	Low-level input voltage low	$V_{REG18} = 1.8\text{ V}$		0.54	V
V_{OL}	Low-level output voltage	$I_{OL} = 1\text{ mA}$, $V_{REG18} = 1.8\text{ V}$		0.36	V
C_i	Input capacitance			10	pF
I_{lkg}	Input leakage current		1		μA

6.17 I²C Timing — 100 kHz

PARAMETER	TEST CONDITIONS	MIN	NOM	MAX	UNIT
f_{SCL}	Clock Operating Frequency	SCL duty cycle = 50%		100	kHz
$t_{HD:STA}$	START Condition Hold Time	4.0			μs
t_{LOW}	Low period of the SCL Clock	4.7			μs
t_{HIGH}	High period of the SCL Clock	4.0			μs
$t_{SU:STA}$	Setup repeated START	4.7			μs
$t_{HD:DAT}$	Data hold time (SDA input)	0			ns
$t_{SU:DAT}$	Data setup time (SDA input)	250			ns
t_r	Clock Rise Time	10% to 90%		1000	ns
t_f	Clock Fall Time	90% to 10%		300	ns
$t_{SU:STO}$	Setup time STOP Condition	4.0			μs
t_{BUF}	Bus free time STOP to START	4.7			μs

6.18 I²C Timing — 400 kHz

PARAMETER	TEST CONDITIONS	MIN	NOM	MAX	UNIT
f_{SCL}	Clock Operating Frequency	SCL duty cycle = 50%		400	kHz
$t_{HD:STA}$	START Condition Hold Time	0.6			μs

I²C Timing — 400 kHz (continued)

PARAMETER	TEST CONDITIONS	MIN	NOM	MAX	UNIT
t _{LOW}	Low period of the SCL Clock	1.3			μs
t _{HIGH}	High period of the SCL Clock	600			ns
t _{SU:STA}	Setup repeated START	600			ns
t _{HD:DAT}	Data hold time (SDA input)	0			ns
t _{SU:DAT}	Data setup time (SDA input)	100			ns
t _r	Clock Rise Time	10% to 90%		300	ns
t _f	Clock Fall Time	90% to 10%		300	ns
t _{SU:STO}	Setup time STOP Condition	0.6			μs
t _{BUF}	Bus free time STOP to START	1.3			μs

6.19 HDQ Timing

PARAMETER	TEST CONDITIONS	MIN	NOM	MAX	UNIT	
t _B	Break Time	190			μs	
t _{BR}	Break Recovery Time	40			μs	
t _{HW1}	Host Write 1 Time	Host drives HDQ		50	μs	
t _{HW0}	Host Write 0 Time	Host drives HDQ		145	μs	
t _{CYCH}	Cycle Time, Host to device	Device drives HDQ		190	μs	
t _{CYCD}	Cycle Time, device to Host	Device drives HDQ		250	μs	
t _{DW1}	Device Write 1 Time	Device drives HDQ		50	μs	
t _{DW0}	Device Write 0 Time	Device drives HDQ		145	μs	
t _{RSPS}	Device Response Time	Device drives HDQ		950	μs	
t _{TRND}	Host Turn Around Time	Host drives HDQ after device drives HDQ		250	μs	
t _{RISE}	HDQ Line Rising Time to Logic 1				1.8	μs
t _{RST}	HDQ Reset	Host drives HDQ low before device reset		2.2	s	

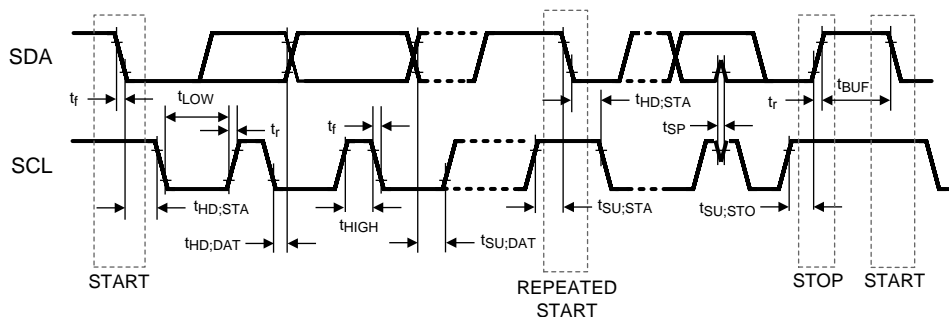
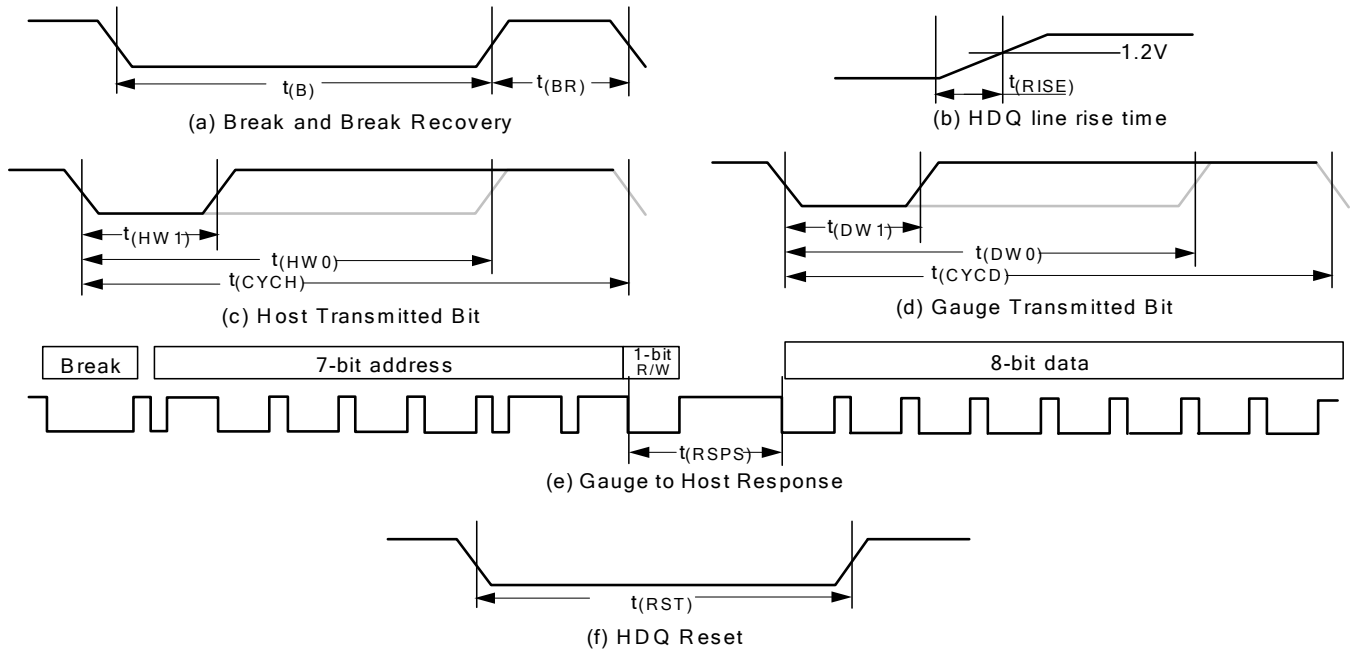

Figure 1. I²C Timing



- a. HDQ Breaking
- b. Rise time of HDQ line
- c. HDQ Host to fuel gauge communication
- d. Fuel gauge to Host communication
- e. Fuel gauge to Host response format
- f. HDQ Host to fuel gauge

Figure 2. HDQ Timing

6.20 Typical Characteristics

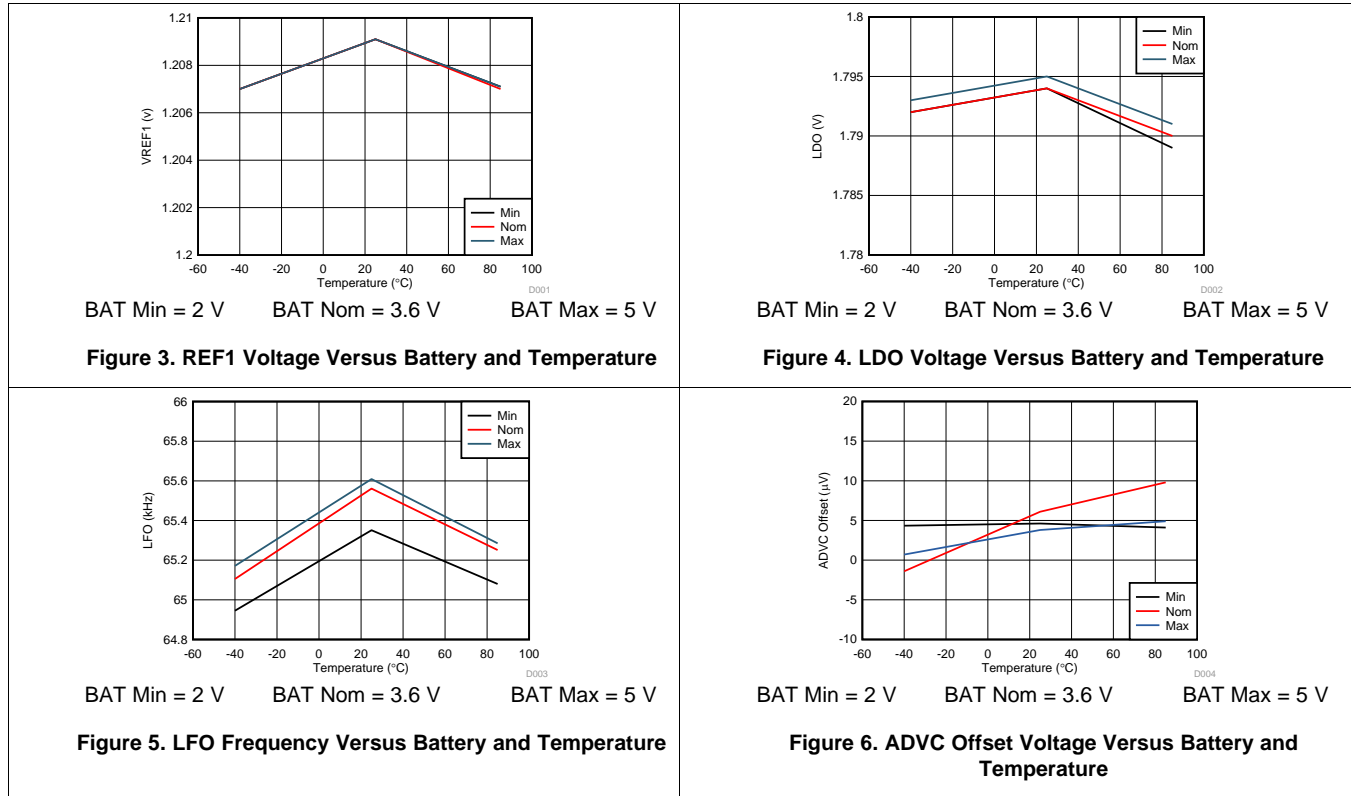

7 Detailed Description

7.1 Overview

The bq27z561 gas gauge is a fully integrated battery manager that employs flash-based firmware to provide a complete solution for battery-stack architectures composed of 1-series cells. The bq27z561 device interfaces with a host system via an I²C or HDQ protocol. High-performance, integrated analog peripherals enable support for a sense resistor down to 1 mΩ, and simultaneous current/voltage data conversion for instant power calculations. The following sections detail all of the major component blocks included as part of the bq27z561 device.

7.2 Functional Block Diagram

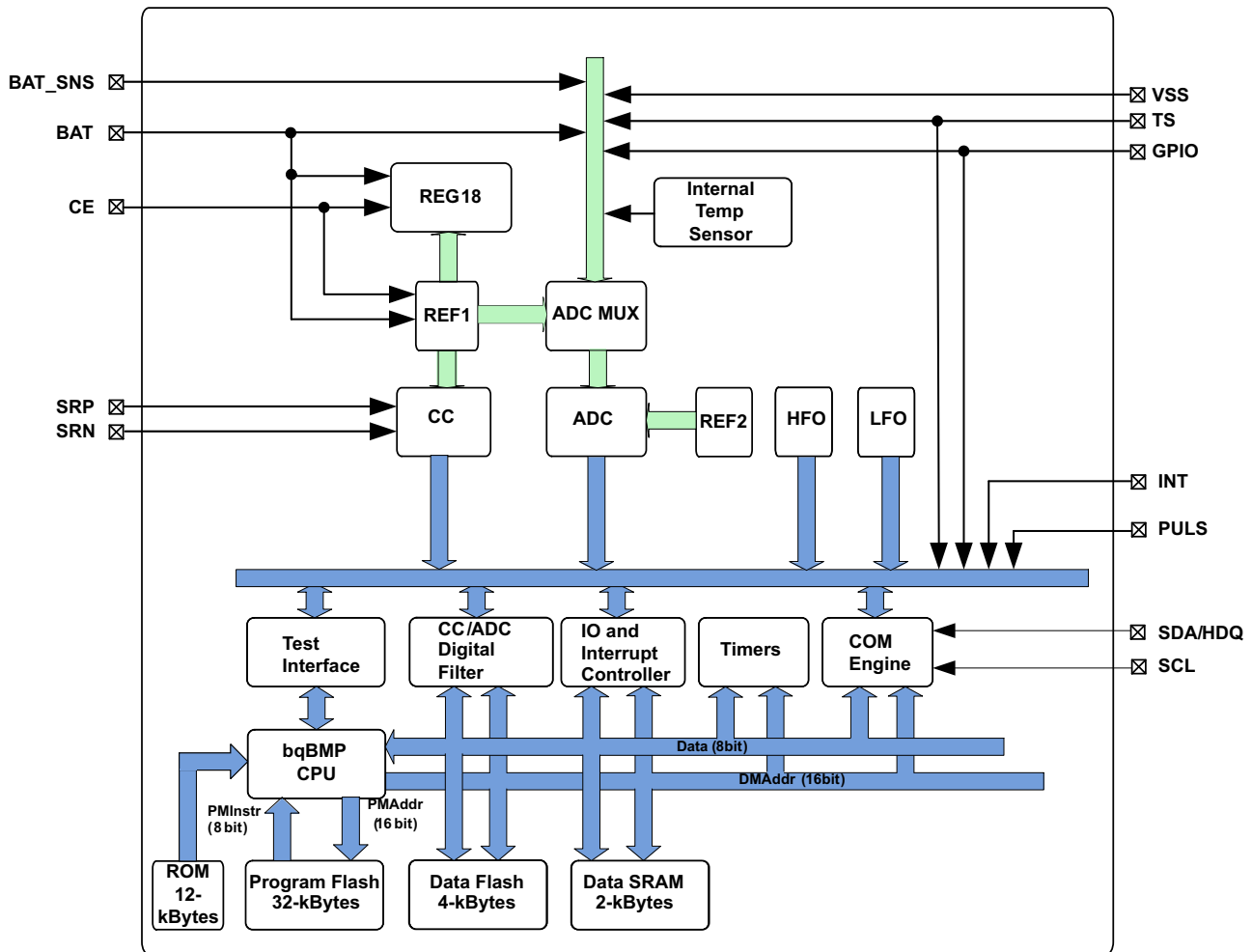

Copyright © 2017, Texas Instruments Incorporated

7.3 Feature Description

7.3.1 bq27z561 Processor

The bq27z561 device uses a custom TI-proprietary processor design that features a Harvard architecture and operates at frequencies up to 4.2 MHz. Using an adaptive, three-stage instruction pipeline, the bq27z561 processor supports variable instruction lengths of 8, 16, or 24 bits.

7.3.2 Battery Parameter Measurements

The bq27z561 device measures cell voltage and current simultaneously, and also measures temperature to calculate the information related to remaining capacity, full charge capacity, state-of-health, and other gauging parameters.

7.3.2.1 Coulomb Counter (CC)

The first ADC is an integrating analog-to-digital converter designed specifically for tracking charge and discharge activity, or coulomb counting, of a rechargeable battery. It features a single-channel differential input that converts the voltage difference across a sense resistor between the SRP and SRN terminals with a resolution of 3.74 μ V.

Feature Description (continued)

7.3.2.2 CC Digital Filter

The CC digital filter generates a 16-bit conversion value from the delta-sigma CC front-end. Its FIR filter uses the HFO clock output. New conversions are available every 1 s.

7.3.2.3 ADC Multiplexer

The ADC multiplexer provides selectable connections to the external pins BAT, BAT_SNS, TS, the internal temperature sensor, internal reference voltages, internal 1.8-V regulator, and VSS ground reference input. In addition, the multiplexer can independently enable the TS input connection to the internal thermistor biasing circuitry, and enables the user to short the multiplexer inputs for test and calibration purposes.

7.3.2.4 Analog-to-Digital Converter (ADC)

The second ADC is a 16-bit delta-sigma converter designed for general-purpose measurements. The ADC automatically scales the input voltage range during sampling based on channel selection. The converter resolution is a function of its full-scale range and number of bits, yielding a 38- μ V resolution.

7.3.2.5 Internal Temperature Sensor

An internal temperature sensor is available on the bq27z561 device to reduce the cost, power, and size of the external components necessary to measure temperature. It is available for connection to the ADC using the multiplexer, and is ideal for quickly determining pack temperature under a variety of operating conditions.

7.3.2.6 External Temperature Sensor Support

The TS input is enabled with an internal 18-k Ω (Typ.) linearization pull-up resistor to support the use of a 10-k Ω (25°C) NTC external thermistor, such as the Semitec 103AT-2. The NTC thermistor should be connected between VSS and the individual TS pin. The analog measurement is then taken via the ADC through its input multiplexer. If a different thermistor type is required, then changes to configurations may be required.

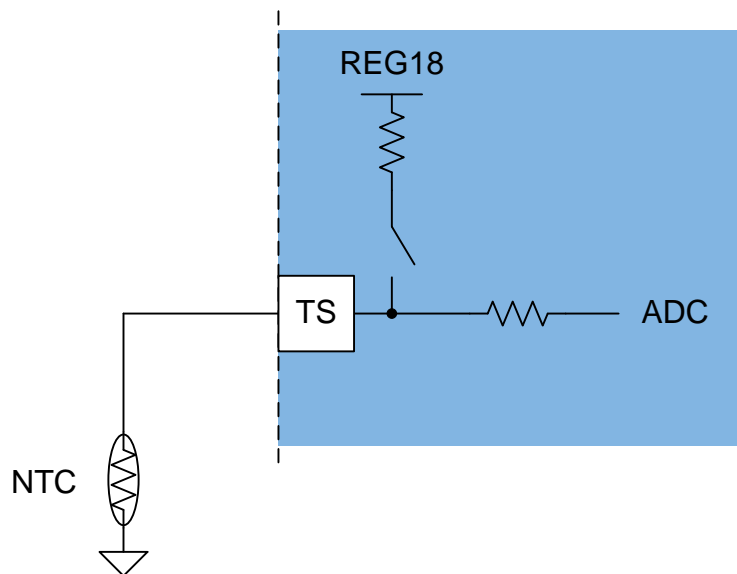

Figure 7. External Thermistor Biasing

7.3.3 Power Supply Control

The bq27z561 device uses the BAT pin as its power source. BAT powers the internal voltage sources that supply references for the device. BAT_SNS is a non-current carrying path and used at the Kelvin reference for BAT.

Feature Description (continued)

7.3.4 Bus Communication Interface

The bq27z561 device has an I²C bus communication interface. Alternatively, the bq27z561 can be configured to communicate through the HDQ pin (shared with SDA).

NOTE

Once the device is switched to the HDQ protocol, it is not reversible.

7.3.5 Low Frequency Oscillator

The bq27z561 device includes a low frequency oscillator (LFO) running at 65.536 kHz.

7.3.6 High Frequency Oscillator

The bq27z561 includes a high frequency oscillator (HFO) running at 16.78 MHz. It is frequency locked to the LFO output and scaled down to 8.388 MHz with a 50% duty cycle.

7.3.7 1.8-V Low Dropout Regulator

The bq27z561 device contains an integrated capacitor-less 1.8-V LDO (REG18) that provides regulated supply voltage for the device CPU and internal digital logic.

7.3.8 Internal Voltage References

The bq27z561 device provides two internal voltage references. REF1 is used by REG18, oscillators, and CC. REF2 is used by the ADC.

7.3.9 Gas Gauging

This device uses the Impedance Track™ technology to measure and determine the available charge in battery cells. See the *Theory and Implementation of Impedance Track Battery Fuel-Gauging Algorithm Application Report (SLUA450)* for further details.

7.3.10 Charge Control Features

This device supports charge control features, such as:

- Reports charging voltage and charging current based on the active temperature range—JEITA temperature ranges T1, T2, T3, T4, T5, and T6
- Provides more complex charging profiles, including sub-ranges within a standard temperature range
- Reports the appropriate charging current required for constant current charging, and the appropriate charging voltage needed for constant voltage charging to a smart charger, using the bus communication interface
- Selects the chemical state-of-charge of each battery cell using the Impedance Track method
- Reports charging faults and indicates charge status via charge and discharge alarms

7.3.11 Authentication

This device supports security with the following features, which can be enabled if desired:

- Authentication by the host using the SHA-256 method
- The gas gauge requires SHA-256 authentication before the device can be unsealed or allow full access.

7.4 Device Functional Modes

This device supports four modes, but the current consumption varies, based on firmware control of certain functions and modes of operation:

- **NORMAL mode:** In this mode, the device performs measurements, calculations, protections, and data updates every 250-ms intervals. Between these intervals, the device is operating in a reduced power stage to minimize total average current consumption.
- **SLEEP mode:** In this mode, the device performs measurements, calculations, and data updates in adjustable time intervals. Between these intervals, the device is operating in a reduced power stage to minimize total

Device Functional Modes (continued)

average current consumption.

- DEEP SLEEP mode: In this mode, the current is reduced slightly while current and voltage are still measured periodically, with a user-defined time between reads.
- OFF mode: The device is completely disabled by pulling CE low. CE disables the internal voltage rail. All non-volatile memory is unprotected.

7.4.1 Lifetime Logging Features

The device supports data logging of several key parameters for warranty and analysis:

- Maximum and Minimum Cell Temperature
- Maximum Current in CHARGE or DISCHARGE Mode
- Maximum and Minimum Cell Voltages

7.4.2 Configuration

The device supports accurate data measurements and data logging of several key parameters.

7.4.2.1 Coulomb Counting

The device uses an integrating delta-sigma analog-to-digital converter (ADC) for current measurement. The ADC measures charge/discharge flow of the battery by measuring the voltage across a very small external sense resistor. The integrating ADC measures a bipolar signal from a range of -100 mV to 100 mV , with a positive value when $V_{(SRP)} - V_{(SRN)}$, indicating charge current and a negative value indicating discharge current.

The current measurement is performed by measuring the voltage drop across the external sense resistor, which can be as low as $1\text{ m}\Omega$, and the polarity of the differential voltage determines if the cell is in the CHARGE or DISCHARGE mode.

7.4.2.2 Cell Voltage Measurements

The bq27z561 gas gauge measures the cell voltage at 1-s intervals using the ADC. This measured value is internally scaled for the ADC and is calibrated to reduce any errors due to offsets. This data is also used for calculating the impedance of the cell for Impedance Track gas gauging.

7.4.2.3 Auto Calibration

The auto-calibration feature helps to cancel any voltage offset across the SRP and SRN pins for accurate measurement of the cell voltage, charge/discharge current, and thermistor temperature. The auto-calibration is performed when there is no communication activity for a minimum of 5 s on the bus lines.

7.4.2.4 Temperature Measurements

This device has an internal sensor for on-die temperature measurements, and the ability to support an external temperature measurement via the external NTC on the TS pin. These two measurements are individually enabled and configured.

8 Applications and Implementation

NOTE

Information in the following applications sections is not part of the TI component specification, and TI does not warrant its accuracy or completeness. TI's customers are responsible for determining suitability of components for their purposes. Customers should validate and test their design implementation to confirm system functionality.

8.1 Application Information

The bq27z561 gas gauge can be used with a 1-series Li-Ion/Li Polymer battery pack. To implement and design a comprehensive set of parameters for a specific battery pack, the user needs Battery Management Studio (bqStudio), which is a graphical user-interface tool installed on a PC during development. The firmware installed in the product has default values, which are summarized in the *bq27z561 Technical Reference Manual (SLUUB07)*. Using the bqStudio tool, these default values can be changed to cater to specific application requirements during development once the system parameters, such as enable/disable of certain features for operation, cell configuration, chemistry that best matches the cell used, and more are known. The final flash image, which is extracted once configuration and testing are complete, will be used for mass production and is referred to as the "golden image."

8.2 Typical Applications

The following is an example bq27z561 application schematic for a single-cell battery pack.

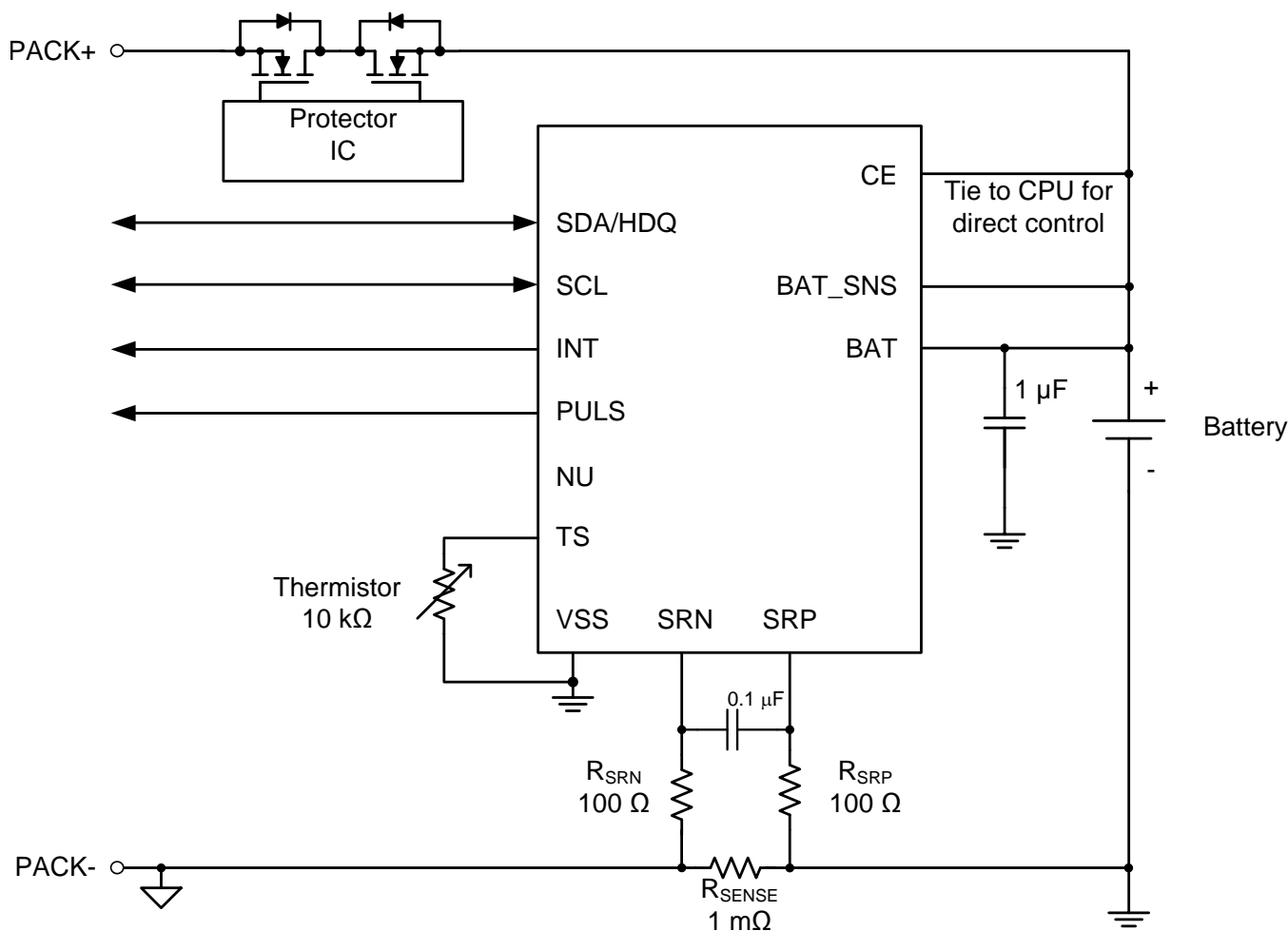

Figure 8. bq27z561 1-Series Cell Typical Implementation

8.2.1 Design Requirements (Default)

Design Parameter	Example
Cell Configuration	1s1p (1 series with 1 parallel)
Design Capacity	5300 mAh
Device Chemistry	Li-Ion
Design Voltage	4000 mV

Typical Applications (continued)

Design Parameter	Example
Cell Low Voltage	2500 mV

8.2.2 Detailed Design Procedure

8.2.2.1 Changing Design Parameters

For the firmware settings needed for the design requirements, refer to the *bq27z561 Technical Reference Manual (SLUUB07)*.

- To change design capacity, set the data flash value (in mAh) in the **Gas Gauging: Design: Design Capacity** register.
- To set device chemistry, go to the data flash **FC Configuration: Data: Device Chemistry**. The bqStudio software automatically populates the correct chemistry identification. This selection is derived from using the bqCHEM feature in the tools and choosing the option that matches the device chemistry from the list.
- To set the design voltage, go to **Gas Gauging: Design: Design Voltage** register.
- To set the Cell **Low Voltage** or clear the Cell **Low Voltage**, use **Settings: Configuration: Init Voltage Low Set** or **Clear**. This is used to set the cell voltage level that will set (clear) the [VOLT_LO] bit in the *Interrupt Status* register.
- To enable the internal temperature and the external temperature sensors: Set **Settings: Configuration: Temperature Enable**: Bit 0 (TSInt) = 1 for the internal sensor; set Bit 1 (TS1) = 1 for the external sensor.

8.2.3 Calibration Process

The calibration of current, voltage, and temperature readings is accessible by writing 0xF081 or 0xF082 to *ManufacturerAccess()*. A detailed procedure is included in the *bq27z561 Technical Reference Manual (SLUUB07)* in the *Calibration* section. The description allows for calibration of cell voltage measurement offset, battery voltage, current calibration, coulomb counter offset, PCB offset, CC gain/capacity gain, and temperature measurement for both internal and external sensors.

8.2.4 Gauging Data Updates

When a battery pack enabled with the bq27z561 gas gauge is cycled, the value of *FullChargeCapacity()* updates several times, including the onset of charge or discharge, charge termination, temperature delta, resistance updates during discharge, and relaxation. [Figure 9](#) shows actual battery voltage, load current, and *FullChargeCapacity()* when some of those updates occur during a single application cycle.

Update points from the plot include:

- Charge termination at 7900 s
- Relaxation at 9900 s
- Resistance update at 11500 s

8.2.4.1 Application Curve

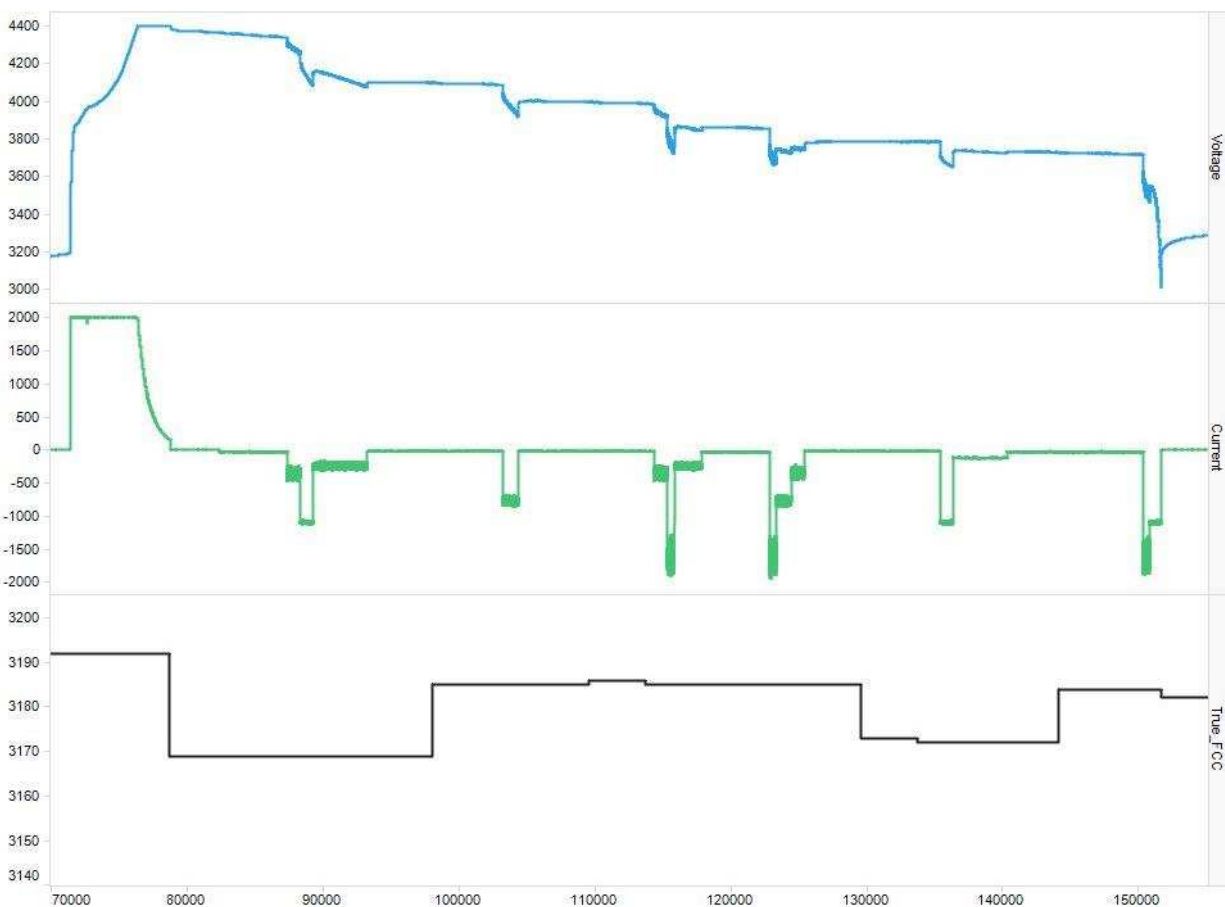

Figure 9. Full Charge Capacity Tracking (X-Axis Is Seconds)

9 Power Supply Requirements

The only power supply is the BAT pin, which is connected to the positive terminal of the battery. The input voltage for the BAT pin will have a minimum of 2 V to a maximum of 5 V.

10 Layout

10.1 Layout Guidelines

- The quality of the Kelvin connections at the sense resistor is critical. The sense resistor must have a temperature coefficient no greater than 50 ppm to minimize current measurement drift with temperature. Choose the value of the sense resistor to correspond to the available overcurrent and short-circuit ranges of the bq27z561 gas gauge. Select the smallest value possible to minimize the negative voltage generated on the bq27z561 VSS node during a short circuit. This pin has an absolute minimum of -0.3 V. Parallel resistors can be used as long as good Kelvin sensing is ensured. The device is designed to support a 1-m Ω to 3-m Ω sense resistor.
- BAT_SNS should be tied directly to the positive connection of the battery. It should not share a path with the BAT pin.
- In reference to the gas gauge circuit the following features require attention for component placement and layout: differential low-pass filter and I²C communication.
- The bq27z561 gas gauge uses an integrating delta-sigma ADC for current measurements. Add a 100- Ω resistor from the sense resistor to the SRP and SRN inputs of the device. Place a 0.1- μ F filter capacitor

Layout Guidelines (continued)

across the SRP and SRN inputs. If required for a circuit, 0.1- μ F filter capacitors can be added for additional noise filtering for each sense input pin to ground. Place all filter components as close as possible to the device. Route the traces from the sense resistor in parallel to the filter circuit. Adding a ground plane around the filter network can provide additional noise immunity.

- The bq27z561 has an internal LDO that is internally compensated and does not require an external decoupling capacitor.
- The I²C clock and data pins have integrated high-voltage ESD protection circuits; however, adding a Zener diode and series resistor provides more robust ESD performance. The I²C clock and data lines have an internal pull-down. When the gas gauge senses that both lines are low (such as during removal of the pack), the device performs auto-offset calibration and then goes into SLEEP mode to conserve power.

10.2 Layout Example

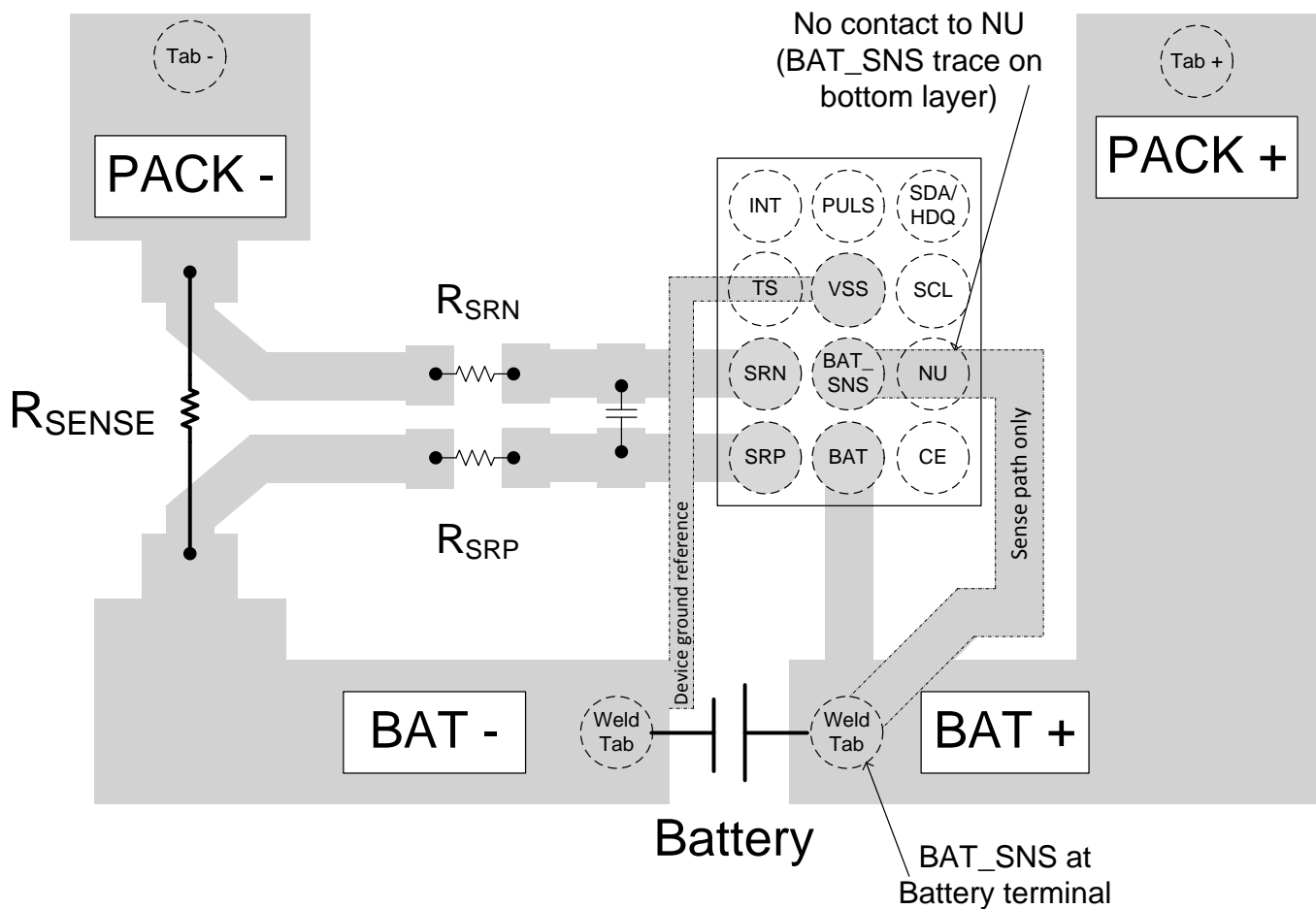

Figure 10. bq27z561 Key Trace Board Layout

11 Device and Documentation Support

11.1 Documentation Support

11.1.1 Related Documentation

- *bq27z561 Technical Reference Manual* ([SLUUB07](#))
- *Theory and Implementation of Impedance Track Battery Fuel-Gauging Algorithm Application Report* ([SLUA364](#))

11.2 Receiving Notification of Documentation Updates

To receive notification of documentation updates, navigate to the device product folder on ti.com. In the upper right corner, click on **Alert me** to register and receive a weekly digest of any product information that has changed. For change details, review the revision history included in any revised document.

11.3 Community Resources

The following links connect to TI community resources. Linked contents are provided "AS IS" by the respective contributors. They do not constitute TI specifications and do not necessarily reflect TI's views; see TI's [Terms of Use](#).

TI E2E™ Online Community *TI's Engineer-to-Engineer (E2E) Community*. Created to foster collaboration among engineers. At e2e.ti.com, you can ask questions, share knowledge, explore ideas and help solve problems with fellow engineers.

Design Support *TI's Design Support* Quickly find helpful E2E forums along with design support tools and contact information for technical support.

11.4 Trademarks

Impedance Track, E2E are trademarks of Texas Instruments.
All other trademarks are the property of their respective owners.

11.5 Electrostatic Discharge Caution



This integrated circuit can be damaged by ESD. Texas Instruments recommends that all integrated circuits be handled with appropriate precautions. Failure to observe proper handling and installation procedures can cause damage.

ESD damage can range from subtle performance degradation to complete device failure. Precision integrated circuits may be more susceptible to damage because very small parametric changes could cause the device not to meet its published specifications.

11.6 Glossary

[SLYZ022](#) — *TI Glossary*.

This glossary lists and explains terms, acronyms, and definitions.

12 Mechanical, Packaging, Orderable Information

The following pages include mechanical, packaging, and orderable information. This information is the most current data available for the designated devices. This data is subject to change without notice and revision of this document. For browser-based versions of this data sheet, refer to the left-hand navigation.

PACKAGING INFORMATION

Orderable Device	Status (1)	Package Type	Package Drawing	Pins	Package Qty	Eco Plan (2)	Lead/Ball Finish (6)	MSL Peak Temp (3)	Op Temp (°C)	Device Marking (4/5)	Samples
BQ27Z561YPHR	PREVIEW	DSBGA	YPH	12	3000	Green (RoHS & no Sb/Br)	SAC396	Level-1-260C-UNLIM	-40 to 85	BQ27Z561	
BQ27Z561YPHT	PREVIEW	DSBGA	YPH	12	250	Green (RoHS & no Sb/Br)	SAC396	Level-1-260C-UNLIM	-40 to 85	BQ27Z561	

(1) The marketing status values are defined as follows:

ACTIVE: Product device recommended for new designs.

LIFEBUY: TI has announced that the device will be discontinued, and a lifetime-buy period is in effect.

NRND: Not recommended for new designs. Device is in production to support existing customers, but TI does not recommend using this part in a new design.

PREVIEW: Device has been announced but is not in production. Samples may or may not be available.

OBSOLETE: TI has discontinued the production of the device.

(2) **RoHS:** TI defines "RoHS" to mean semiconductor products that are compliant with the current EU RoHS requirements for all 10 RoHS substances, including the requirement that RoHS substance do not exceed 0.1% by weight in homogeneous materials. Where designed to be soldered at high temperatures, "RoHS" products are suitable for use in specified lead-free processes. TI may reference these types of products as "Pb-Free".

RoHS Exempt: TI defines "RoHS Exempt" to mean products that contain lead but are compliant with EU RoHS pursuant to a specific EU RoHS exemption.

Green: TI defines "Green" to mean the content of Chlorine (Cl) and Bromine (Br) based flame retardants meet JS709B low halogen requirements of <=1000ppm threshold. Antimony trioxide based flame retardants must also meet the <=1000ppm threshold requirement.

(3) MSL, Peak Temp. - The Moisture Sensitivity Level rating according to the JEDEC industry standard classifications, and peak solder temperature.

(4) There may be additional marking, which relates to the logo, the lot trace code information, or the environmental category on the device.

(5) Multiple Device Markings will be inside parentheses. Only one Device Marking contained in parentheses and separated by a "~" will appear on a device. If a line is indented then it is a continuation of the previous line and the two combined represent the entire Device Marking for that device.

(6) Lead/Ball Finish - Orderable Devices may have multiple material finish options. Finish options are separated by a vertical ruled line. Lead/Ball Finish values may wrap to two lines if the finish value exceeds the maximum column width.

Important Information and Disclaimer:The information provided on this page represents TI's knowledge and belief as of the date that it is provided. TI bases its knowledge and belief on information provided by third parties, and makes no representation or warranty as to the accuracy of such information. Efforts are underway to better integrate information from third parties. TI has taken and continues to take reasonable steps to provide representative and accurate information but may not have conducted destructive testing or chemical analysis on incoming materials and chemicals. TI and TI suppliers consider certain information to be proprietary, and thus CAS numbers and other limited information may not be available for release.

In no event shall TI's liability arising out of such information exceed the total purchase price of the TI part(s) at issue in this document sold by TI to Customer on an annual basis.

TAPE AND REEL INFORMATION

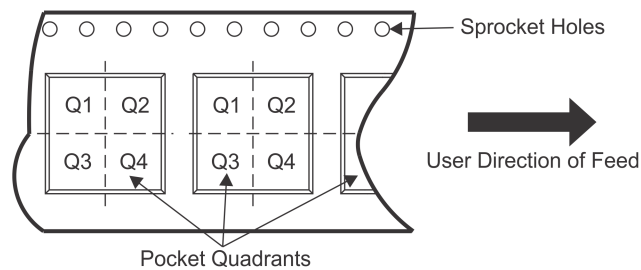
QUADRANT ASSIGNMENTS FOR PIN 1 ORIENTATION IN TAPE

*All dimensions are nominal

Device	Package Type	Package Drawing	Pins	SPQ	Reel Diameter (mm)	Reel Width W1 (mm)	A0 (mm)	B0 (mm)	K0 (mm)	P1 (mm)	W (mm)	Pin1 Quadrant
BQ27Z561YPHR	DSBGA	YPH	12	3000	180.0	8.4	1.83	2.2	0.53	4.0	8.0	Q1

TAPE AND REEL BOX DIMENSIONS



*All dimensions are nominal

Device	Package Type	Package Drawing	Pins	SPQ	Length (mm)	Width (mm)	Height (mm)
BQ27Z561YPHR	DSBGA	YPH	12	3000	182.0	182.0	20.0

IMPORTANT NOTICE

Texas Instruments Incorporated (TI) reserves the right to make corrections, enhancements, improvements and other changes to its semiconductor products and services per JESD46, latest issue, and to discontinue any product or service per JESD48, latest issue. Buyers should obtain the latest relevant information before placing orders and should verify that such information is current and complete.

TI's published terms of sale for semiconductor products (<http://www.ti.com/sc/docs/stdterms.htm>) apply to the sale of packaged integrated circuit products that TI has qualified and released to market. Additional terms may apply to the use or sale of other types of TI products and services.

Reproduction of significant portions of TI information in TI data sheets is permissible only if reproduction is without alteration and is accompanied by all associated warranties, conditions, limitations, and notices. TI is not responsible or liable for such reproduced documentation. Information of third parties may be subject to additional restrictions. Resale of TI products or services with statements different from or beyond the parameters stated by TI for that product or service voids all express and any implied warranties for the associated TI product or service and is an unfair and deceptive business practice. TI is not responsible or liable for any such statements.

Buyers and others who are developing systems that incorporate TI products (collectively, "Designers") understand and agree that Designers remain responsible for using their independent analysis, evaluation and judgment in designing their applications and that Designers have full and exclusive responsibility to assure the safety of Designers' applications and compliance of their applications (and of all TI products used in or for Designers' applications) with all applicable regulations, laws and other applicable requirements. Designer represents that, with respect to their applications, Designer has all the necessary expertise to create and implement safeguards that (1) anticipate dangerous consequences of failures, (2) monitor failures and their consequences, and (3) lessen the likelihood of failures that might cause harm and take appropriate actions. Designer agrees that prior to using or distributing any applications that include TI products, Designer will thoroughly test such applications and the functionality of such TI products as used in such applications.

TI's provision of technical, application or other design advice, quality characterization, reliability data or other services or information, including, but not limited to, reference designs and materials relating to evaluation modules, (collectively, "TI Resources") are intended to assist designers who are developing applications that incorporate TI products; by downloading, accessing or using TI Resources in any way, Designer (individually or, if Designer is acting on behalf of a company, Designer's company) agrees to use any particular TI Resource solely for this purpose and subject to the terms of this Notice.

TI's provision of TI Resources does not expand or otherwise alter TI's applicable published warranties or warranty disclaimers for TI products, and no additional obligations or liabilities arise from TI providing such TI Resources. TI reserves the right to make corrections, enhancements, improvements and other changes to its TI Resources. TI has not conducted any testing other than that specifically described in the published documentation for a particular TI Resource.

Designer is authorized to use, copy and modify any individual TI Resource only in connection with the development of applications that include the TI product(s) identified in such TI Resource. NO OTHER LICENSE, EXPRESS OR IMPLIED, BY ESTOPPEL OR OTHERWISE TO ANY OTHER TI INTELLECTUAL PROPERTY RIGHT, AND NO LICENSE TO ANY TECHNOLOGY OR INTELLECTUAL PROPERTY RIGHT OF TI OR ANY THIRD PARTY IS GRANTED HEREIN, including but not limited to any patent right, copyright, mask work right, or other intellectual property right relating to any combination, machine, or process in which TI products or services are used. Information regarding or referencing third-party products or services does not constitute a license to use such products or services, or a warranty or endorsement thereof. Use of TI Resources may require a license from a third party under the patents or other intellectual property of the third party, or a license from TI under the patents or other intellectual property of TI.

TI RESOURCES ARE PROVIDED "AS IS" AND WITH ALL FAULTS. TI DISCLAIMS ALL OTHER WARRANTIES OR REPRESENTATIONS, EXPRESS OR IMPLIED, REGARDING RESOURCES OR USE THEREOF, INCLUDING BUT NOT LIMITED TO ACCURACY OR COMPLETENESS, TITLE, ANY EPIDEMIC FAILURE WARRANTY AND ANY IMPLIED WARRANTIES OF MERCHANTABILITY, FITNESS FOR A PARTICULAR PURPOSE, AND NON-INFRINGEMENT OF ANY THIRD PARTY INTELLECTUAL PROPERTY RIGHTS. TI SHALL NOT BE LIABLE FOR AND SHALL NOT DEFEND OR INDEMNIFY DESIGNER AGAINST ANY CLAIM, INCLUDING BUT NOT LIMITED TO ANY INFRINGEMENT CLAIM THAT RELATES TO OR IS BASED ON ANY COMBINATION OF PRODUCTS EVEN IF DESCRIBED IN TI RESOURCES OR OTHERWISE. IN NO EVENT SHALL TI BE LIABLE FOR ANY ACTUAL, DIRECT, SPECIAL, COLLATERAL, INDIRECT, PUNITIVE, INCIDENTAL, CONSEQUENTIAL OR EXEMPLARY DAMAGES IN CONNECTION WITH OR ARISING OUT OF TI RESOURCES OR USE THEREOF, AND REGARDLESS OF WHETHER TI HAS BEEN ADVISED OF THE POSSIBILITY OF SUCH DAMAGES.

Unless TI has explicitly designated an individual product as meeting the requirements of a particular industry standard (e.g., ISO/TS 16949 and ISO 26262), TI is not responsible for any failure to meet such industry standard requirements.

Where TI specifically promotes products as facilitating functional safety or as compliant with industry functional safety standards, such products are intended to help enable customers to design and create their own applications that meet applicable functional safety standards and requirements. Using products in an application does not by itself establish any safety features in the application. Designers must ensure compliance with safety-related requirements and standards applicable to their applications. Designer may not use any TI products in life-critical medical equipment unless authorized officers of the parties have executed a special contract specifically governing such use. Life-critical medical equipment is medical equipment where failure of such equipment would cause serious bodily injury or death (e.g., life support, pacemakers, defibrillators, heart pumps, neurostimulators, and implantables). Such equipment includes, without limitation, all medical devices identified by the U.S. Food and Drug Administration as Class III devices and equivalent classifications outside the U.S.

TI may expressly designate certain products as completing a particular qualification (e.g., Q100, Military Grade, or Enhanced Product). Designers agree that it has the necessary expertise to select the product with the appropriate qualification designation for their applications and that proper product selection is at Designers' own risk. Designers are solely responsible for compliance with all legal and regulatory requirements in connection with such selection.

Designer will fully indemnify TI and its representatives against any damages, costs, losses, and/or liabilities arising out of Designer's non-compliance with the terms and provisions of this Notice.