

## Product Brief

# Antenna aperture tuning solutions

Maximizing battery life and data rate for 3G/4G mobile devices

In a decade the mobile phones went from simple handheld telephone to supercomputing feature-full smartphone devices. This transformed the way we access and exchange information in a ubiquitous way. But all the new features, radios and huge processing power require always more space and more antennas on a small board. While antenna size shrunk, larger bandwidth of operation has been requested (LTE, WiFi, etc.) ultimately resulting in poor antenna performance. Antenna aperture tuning solutions are the necessary toolbox for smartphone vendors to make small but efficient antennas.

### Infineon antenna tuning solutions value

The antenna tuning devices based on Infineon's RF CMOS switch technology are designed for ultra-small size, high ruggedness in mismatch conditions, low parasitic and best linearity. Improved antenna efficiency directly translates into better signal quality, fastest data transmission and longer battery life. All devices offer generic GPIO interfaces for smooth antenna control and system integration.

### Applications

- > Smartphones, tablets and other mobile devices
- > Smart metering

### Key Benefits

- > Ultra small 1.5 x 1.1 mm TSNP-10-1 plastic package
- > Highest quality level
- > Improves TIS (Rx insensitivity to VSWR)
- > Improves TRP (Tx insensitivity to VSWR)
- > Higher flexibility in antenna form
- > Less system current consumption (PA) through optimized matching

Product	Product status	Switch type	Control interface	Frequency range [GHz]	ON state resistance ( $R_{ON}$ ) [ $\Omega$ ]	OFF state capacitance ( $C_{OFF}$ ) [fF]	Max operating voltage ( $V_{PK}$ ) [V]
BGSA12GN10	Production	SPDT	GPIO	0.1 ... 5.0	1.6	120	36
BGSA13GN10	Production	SP3T	GPIO	0.1 ... 5.0	0.8 <sup>1)</sup>	120	36
BGSA14GN10	Production	SP4T	GPIO	0.1 ... 5.0	1.6	120	36

1) 1 port optimized for ultra-low 0.8  $\Omega$   $R_{ON}$

# Antenna aperture tuning solutions

Maximizing battery life and data rate for 3G/4G mobile devices

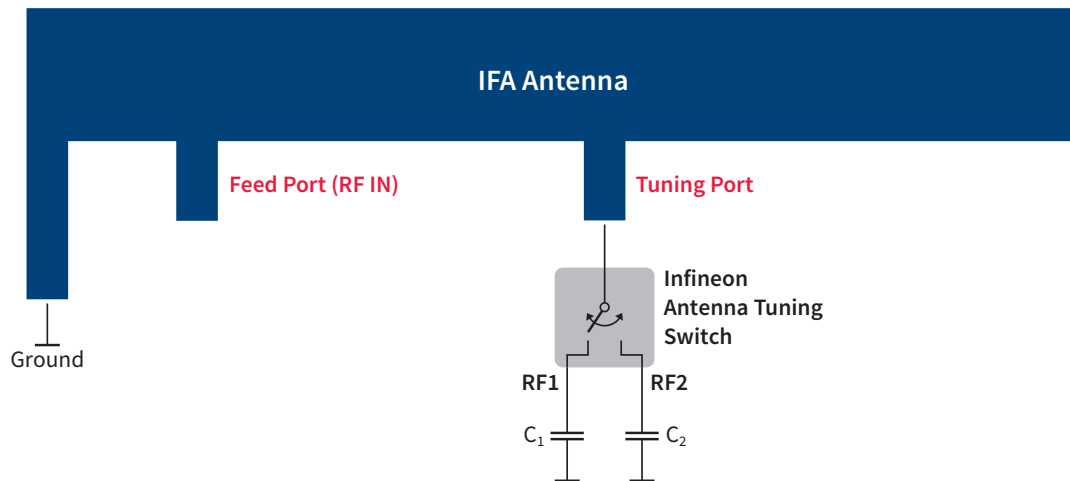

## Infineon's antenna tuning devices with optimized form factor and design

The BGSAxxGN10 ICs are provided in the smallest packages available on the market, which is critical for space limited applications with multiple LTE bands in the latest generation of smartphones and other portable devices. All products are shipped in a RoHS compliant plastic package with dimensions of only 1.5 mm x 1.1 mm which is 60 percent smaller in size compared to state-of-the-art CSP type devices on the market.

### Orderable part No.

- > BGSA12GN10E6327XTSA1
- > BGSA13GN10E6327XTSA1
- > BGSA14GN10E6327XTSA1

Published by  
Infineon Technologies AG  
85579 Neubiberg, Germany

© 2015 Infineon Technologies AG.  
All Rights Reserved.

### Please note!

THIS DOCUMENT IS FOR INFORMATION PURPOSES ONLY AND ANY INFORMATION GIVEN HEREIN SHALL IN NO EVENT BE REGARDED AS A WARRANTY, GUARANTEE OR DESCRIPTION OF ANY FUNCTIONALITY, CONDITIONS AND/OR QUALITY OF OUR PRODUCTS OR ANY SUITABILITY FOR A PARTICULAR PURPOSE. WITH REGARD TO THE TECHNICAL SPECIFICATIONS OF OUR PRODUCTS, WE KINDLY ASK YOU TO REFER TO THE RELEVANT PRODUCT DATA SHEETS PROVIDED BY US. OUR CUSTOMERS AND THEIR TECHNICAL DEPARTMENTS ARE REQUIRED TO EVALUATE THE SUITABILITY OF OUR PRODUCTS FOR THE INTENDED APPLICATION.

WE RESERVE THE RIGHT TO CHANGE THIS DOCUMENT AND/OR THE INFORMATION GIVEN HEREIN AT ANY TIME.

### Additional information

For further information on technologies, our products, the application of our products, delivery terms and conditions and/or prices please contact your nearest Infineon Technologies office ([www.infineon.com](http://www.infineon.com)).

### Warnings

Due to technical requirements, our products may contain dangerous substances. For information on the types in question please contact your nearest Infineon Technologies office.

Except as otherwise explicitly approved by us in a written document signed by authorized representatives of Infineon Technologies, our products may not be used in any life endangering applications, including but not limited to medical, nuclear, military, life critical or any other applications where a failure of the product or any consequences of the use thereof can result in personal injury.