

# DATA SHEET

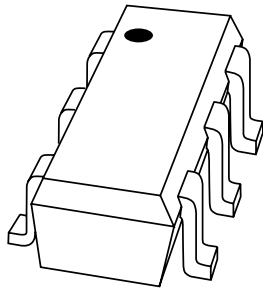

## **BGA2771** MMIC wideband amplifier

Product specification  
Supersedes data of 2001 Oct 19

2002 Aug 06

# MMIC wideband amplifier

# BGA2771

### FEATURES

- Internally matched
- Wide frequency range
- Very flat gain
- High output power
- High linearity
- Unconditionally stable.

### APPLICATIONS

- Cable systems
- LNB IF amplifiers
- General purpose
- ISM.

### DESCRIPTION

Silicon Monolithic Microwave Integrated Circuit (MMIC) wideband amplifier with internal matching circuit in a 6-pin SOT363 SMD plastic package.

### PINNING

PIN	DESCRIPTION
1	V <sub>S</sub>
2, 5	GND2
3	RF out
4	GND1
6	RF in

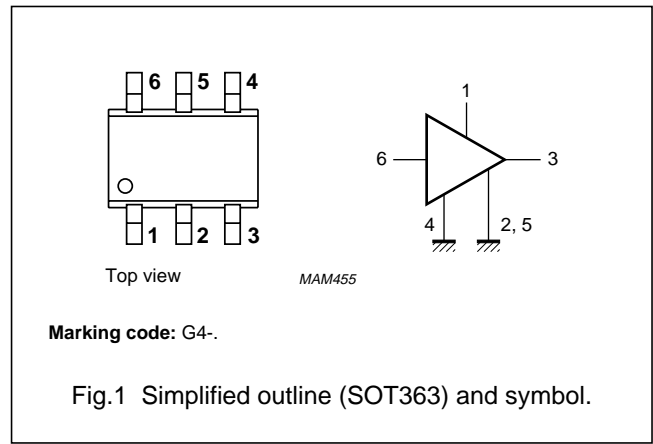

### QUICK REFERENCE DATA

SYMBOL	PARAMETER	CONDITIONS	TYP.	MAX.	UNIT
V <sub>S</sub>	DC supply voltage		3	4	V
I <sub>S</sub>	DC supply current		33.3	–	mA
S <sub>21</sub>   <sup>2</sup>	insertion power gain	f = 1 GHz	21.4	–	dB
NF	noise figure	f = 1 GHz	4.5	–	dB
P <sub>L(sat)</sub>	saturated load power	f = 1 GHz	13.2	–	dBm

### CAUTION

This product is supplied in anti-static packing to prevent damage caused by electrostatic discharge during transport and handling. For further information, refer to Philips specs.: SNW-EQ-608, SNW-FQ-302A and SNW-FQ-302B.

## MMIC wideband amplifier

BGA2771

**LIMITING VALUES**

In accordance with the Absolute Maximum Rating System (IEC 60134).

SYMBOL	PARAMETER	CONDITIONS	MIN.	MAX.	UNIT
$V_S$	DC supply voltage	RF input AC coupled	–	4	V
$I_S$	supply current		–	50	mA
$P_{tot}$	total power dissipation	$T_s \leq 80\text{ °C}$	–	200	mW
$T_{stg}$	storage temperature		–65	+150	°C
$T_j$	operating junction temperature		–	150	°C
$P_D$	maximum drive power		–	10	dBm

**THERMAL CHARACTERISTICS**

SYMBOL	PARAMETER	CONDITIONS	VALUE	UNIT
$R_{th\ j-s}$	thermal resistance from junction to solder point	$P_{tot} = 200\text{ mW}; T_s \leq 80\text{ °C}$	300	K/W

**CHARACTERISTICS** $V_S = 3\text{ V}; I_S = 33\text{ mA}; f = 1\text{ GHz}; T_j = 25\text{ °C};$  unless otherwise specified.

SYMBOL	PARAMETER	CONDITIONS	MIN.	TYP.	MAX.	UNIT
$I_S$	supply current		29	33.3	45	mA
$ S_{21} ^2$	insertion power gain	f = 1 GHz	–	21.4	–	dB
		f = 2 GHz	–	20.8	–	dB
$R_{L\ IN}$	return losses input	f = 1 GHz	–	17	–	dB
		f = 2 GHz	–	13	–	dB
$R_{L\ OUT}$	return losses output	f = 1 GHz	–	9	–	dB
		f = 2 GHz	–	9	–	dB
NF	noise figure	f = 1 GHz	–	4.5	–	dB
		f = 2 GHz	–	4.7	–	dB
BW	bandwidth	at $ S_{21} ^2 -3\text{ dB}$ below flat gain at 1 GHz	–	2.4	–	GHz
$P_{L(sat)}$	saturated load power	f = 1 GHz	–	13.2	–	dBm
		f = 2 GHz	–	10.5	–	dBm
$P_{L\ 1\ dB}$	load power	at 1 dB gain compression; f = 1 GHz	–	12.1	–	dBm
		at 1 dB gain compression; f = 2 GHz	–	8.4	–	dBm
IP3 <sub>(in)</sub>	input intercept point	f = 1 GHz	–	0.5	–	dBm
		f = 2 GHz	–	–4.3	–	dBm
IP3 <sub>(out)</sub>	output intercept point	f = 1 GHz	–	21.9	–	dBm
		f = 2 GHz	–	16.5	–	dBm

# MMIC wideband amplifier

BGA2771

## APPLICATION INFORMATION

Figure 2 shows a typical application circuit for the BGA2771 MMIC. The device is internally matched to 50 Ω, and therefore does not need any external matching. The value of the input and output DC blocking capacitors C2 and C3 should be not more than 100 pF for applications above 100 MHz. However, when the device is operated below 100 MHz, the capacitor value should be increased.

The nominal value of the RF choke L1 is 100 nH. At frequencies below 100 MHz this value should be increased to 220 nH. At frequencies above 1 GHz a much lower value must be used (e.g. 10 nH) to improve return losses. For optimal results, a good quality chip inductor such as the TDK MLG 1608 (0603), or a wire-wound SMD type should be chosen.

Both the RF choke L1 and the 22 nF supply decoupling capacitor C1 should be located as closely as possible to the MMIC.

Separate paths must be used for the ground planes of the ground pins GND1 and GND2, and these paths must be as short as possible. When using vias, use multiple vias per pin in order to limit ground path inductance.

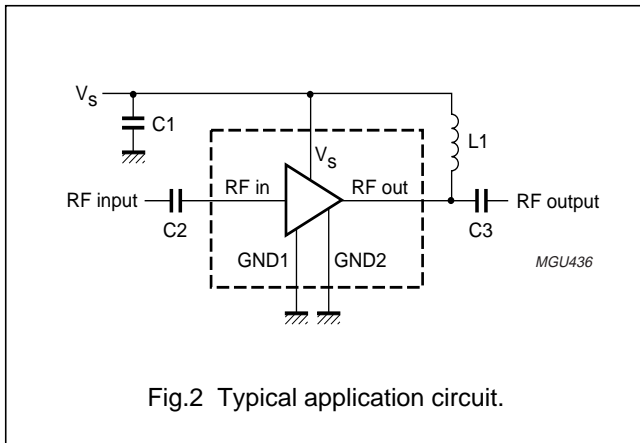

Fig.2 Typical application circuit.

Figure 3 shows two cascaded MMICs. This configuration doubles overall gain while preserving broadband characteristics. Supply decoupling and grounding conditions for each MMIC are the same as those for the circuit of Fig.2.

The excellent wideband characteristics of the MMIC make it an ideal building block in IF amplifier applications such as LBNs (see Fig.4).

As a buffer amplifier between an LNA and a mixer in a receiver circuit, the MMIC offers an easy matching, low noise solution (see Fig.5).

In Fig.6 the MMIC is used as a driver to the power amplifier as part of a transmitter circuit. Good linear performance and matched input and output offer quick design solutions in such applications.

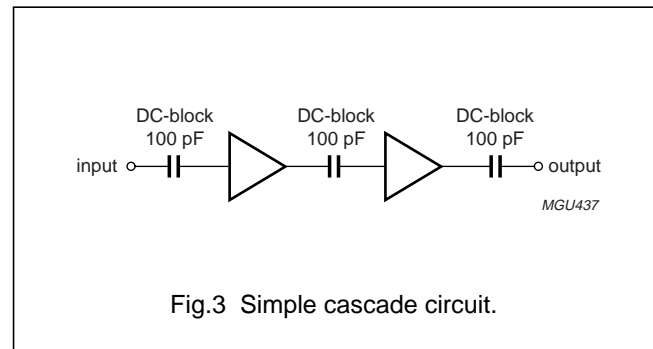

Fig.3 Simple cascade circuit.

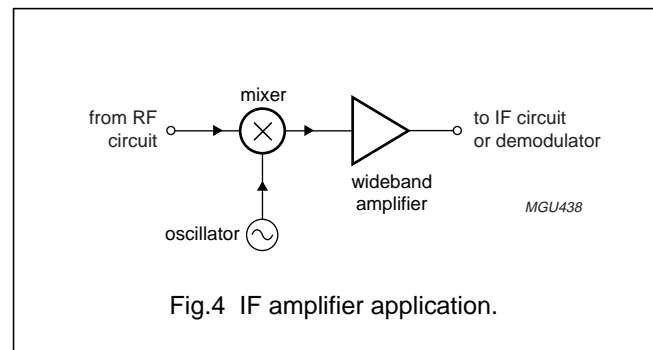

Fig.4 IF amplifier application.

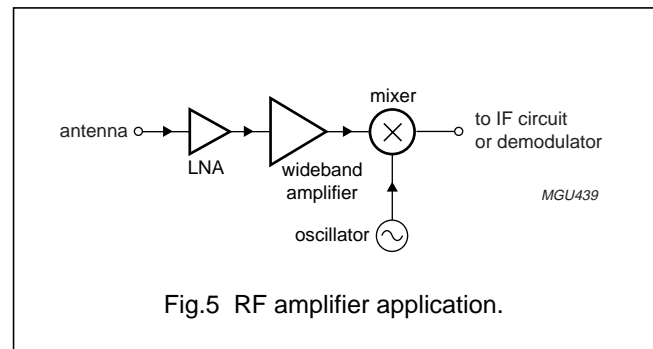

Fig.5 RF amplifier application.

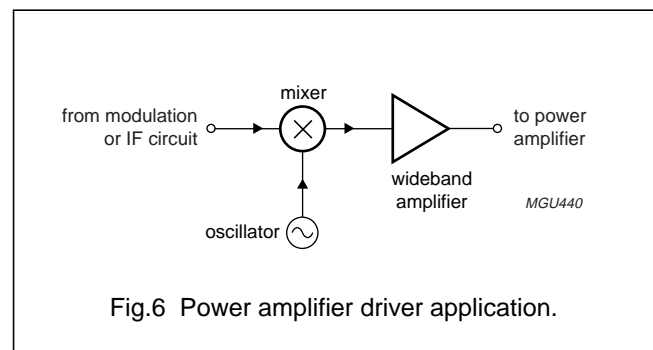
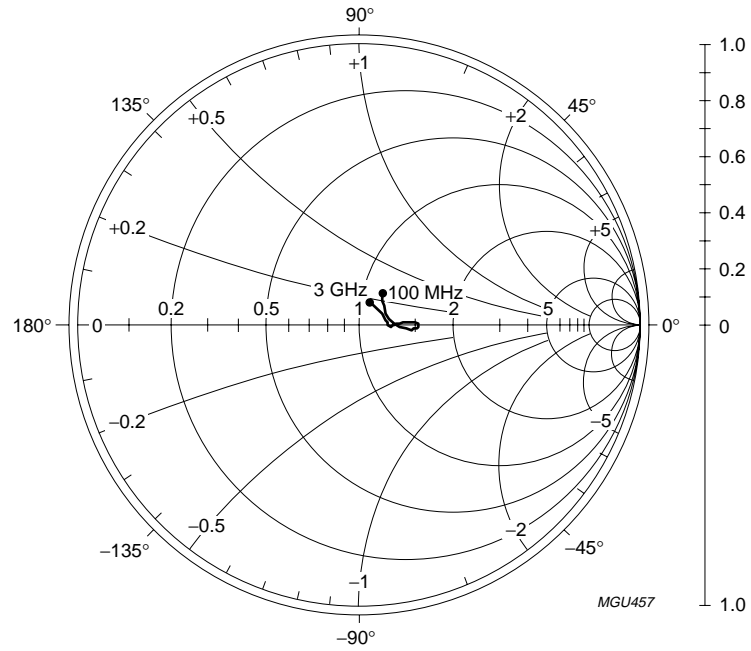

Fig.6 Power amplifier driver application.

MMIC wideband amplifier

BGA2771



$I_S = 33.4 \text{ mA}$ ;  $V_S = 3 \text{ V}$ ;  $P_D = -30 \text{ dBm}$ ;  $Z_O = 50 \Omega$ .

Fig.7 Input reflection coefficient ( $s_{11}$ ); typical values.

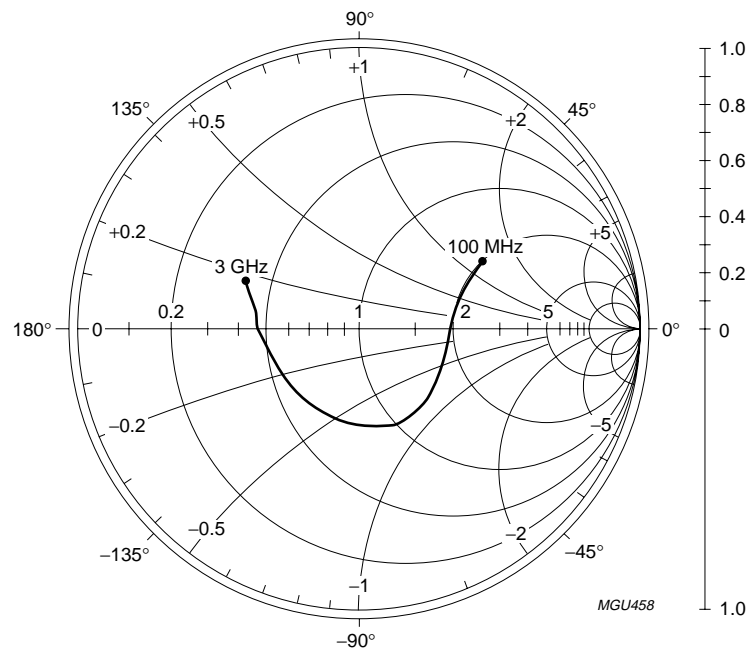

$I_S = 33.4 \text{ mA}$ ;  $V_S = 3 \text{ V}$ ;  $P_D = -30 \text{ dBm}$ ;  $Z_O = 50 \Omega$ .

Fig.8 Output reflection coefficient ( $s_{22}$ ); typical values.

MMIC wideband amplifier

BGA2771

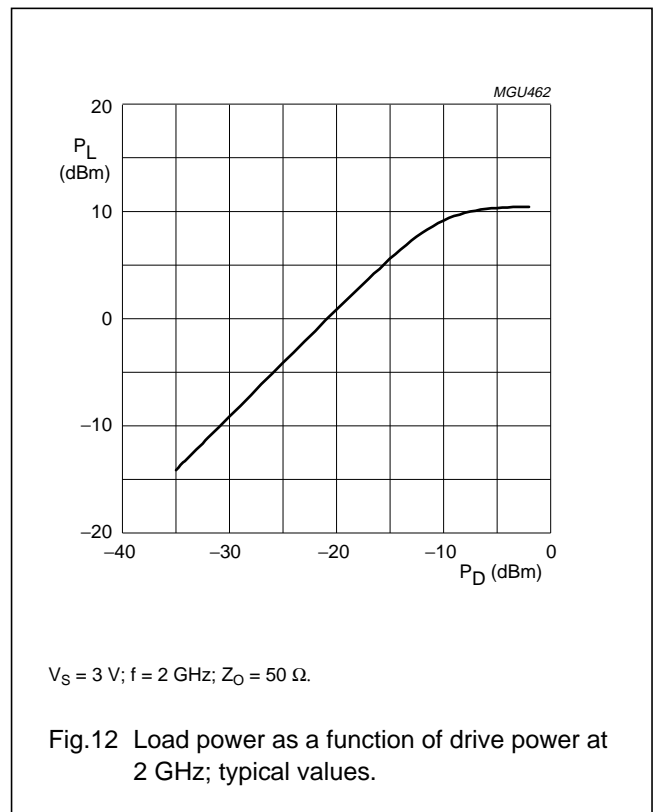
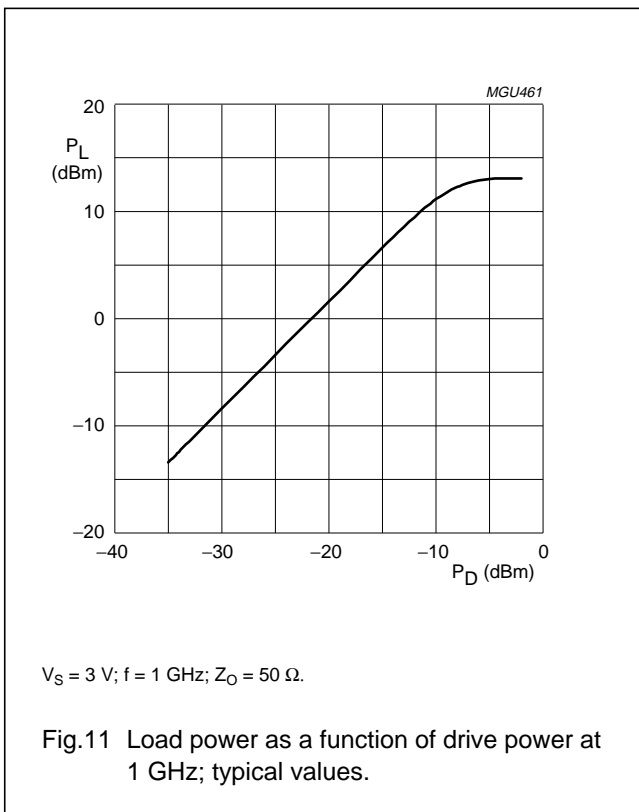
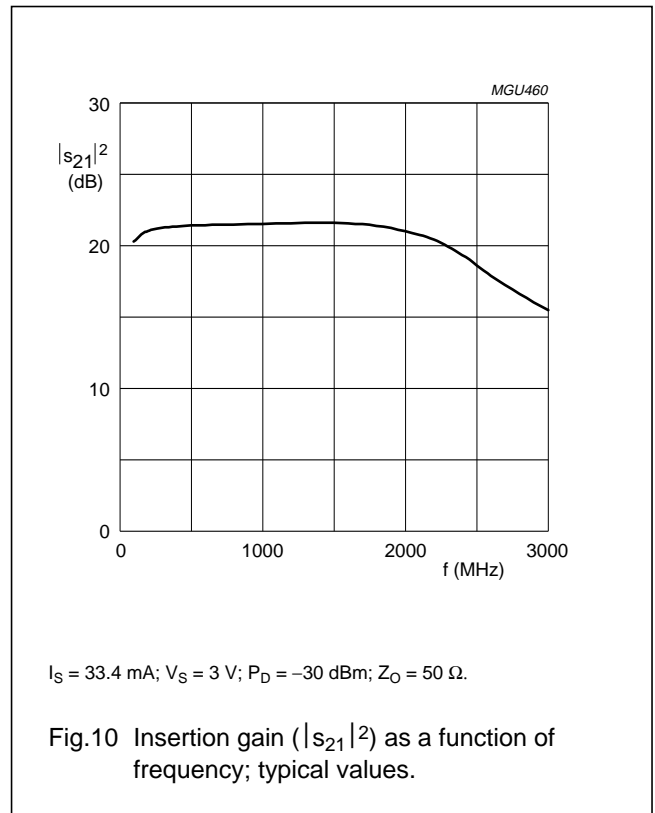
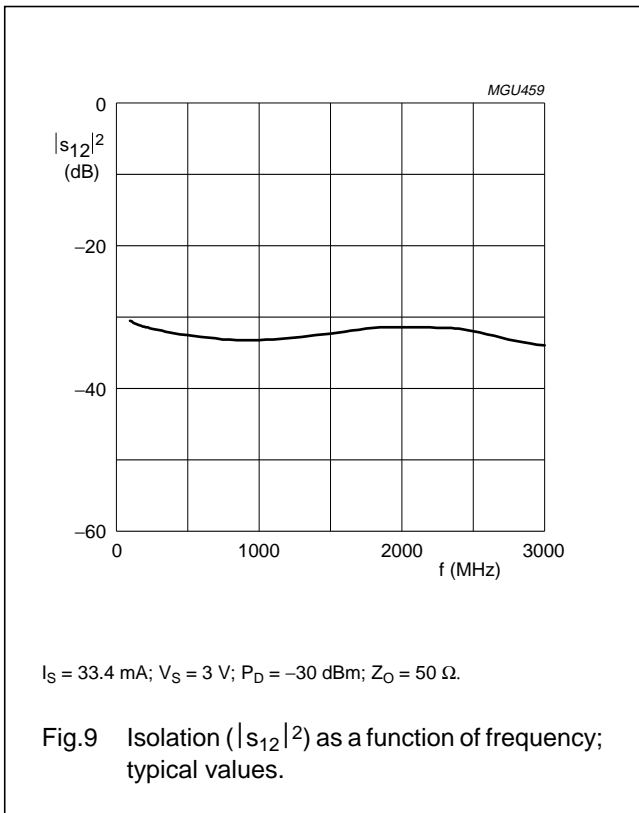

MMIC wideband amplifier

BGA2771

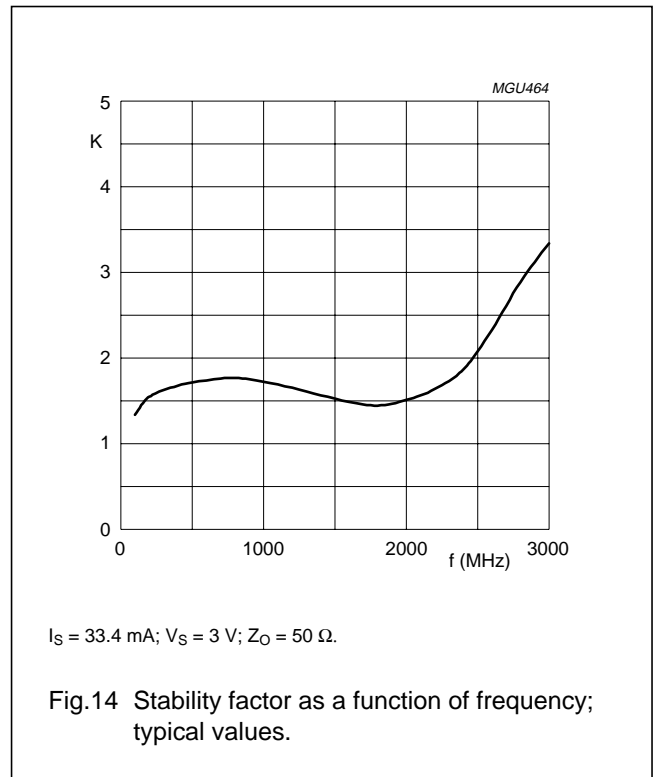
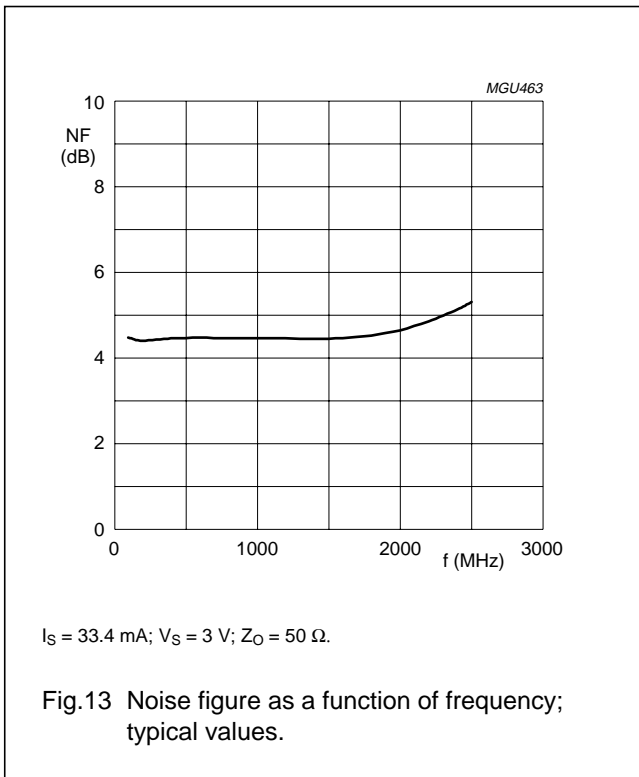

Scattering parameters

$I_S = 33.4 \text{ mA}; V_S = 3 \text{ V}; P_D = -30 \text{ dBm}; Z_O = 50 \Omega; T_{amb} = 25 \text{ }^\circ\text{C}.$

f (MHz)	S <sub>11</sub>		S <sub>21</sub>		S <sub>12</sub>		S <sub>22</sub>	
	MAGNITUDE (ratio)	ANGLE (deg)	MAGNITUDE (ratio)	ANGLE (deg)	MAGNITUDE (ratio)	ANGLE (deg)	MAGNITUDE (ratio)	ANGLE (deg)
100	0.09328	62.11	10.336	25.98	0.02953	13.71	0.50404	29.78
200	0.09722	25.33	11.266	5.910	0.02687	6.556	0.35904	16.09
400	0.10224	5.155	11.693	-13.69	0.02437	0.870	0.31417	-10.34
600	0.10707	-1.282	11.806	-27.51	0.02288	1.273	0.32541	-29.56
800	0.12009	-0.985	11.851	-40.46	0.02176	3.809	0.34755	-44.52
1000	0.13693	1.692	11.931	-53.00	0.02174	8.643	0.36785	-56.69
1200	0.15676	3.594	11.990	-65.95	0.02229	11.84	0.37169	-68.24
1400	0.17873	4.299	12.036	-79.54	0.02341	13.89	0.36720	-79.76
1600	0.20322	3.166	11.953	-93.52	0.02492	15.56	0.35425	-92.62
1800	0.21560	0.032	11.755	-108.7	0.02645	13.77	0.33802	-107.7
2000	0.20901	-2.617	11.224	-124.7	0.02676	11.10	0.32517	-125.3
2200	0.18846	-5.529	10.499	-140.3	0.02653	9.411	0.32259	-145.1
2400	0.14965	-1.870	9.2991	-156.2	0.02605	6.749	0.33529	-164.4
2600	0.11394	11.81	7.8388	-169.3	0.02388	3.622	0.37019	178.5
2800	0.11394	36.35	6.7932	-178.5	0.02139	6.039	0.39826	165.2
3000	0.13292	50.28	5.9348	174.2	0.01987	12.49	0.44613	156.5

MMIC wideband amplifier

BGA2771

PACKAGE OUTLINE

Plastic surface mounted package; 6 leads

SOT363

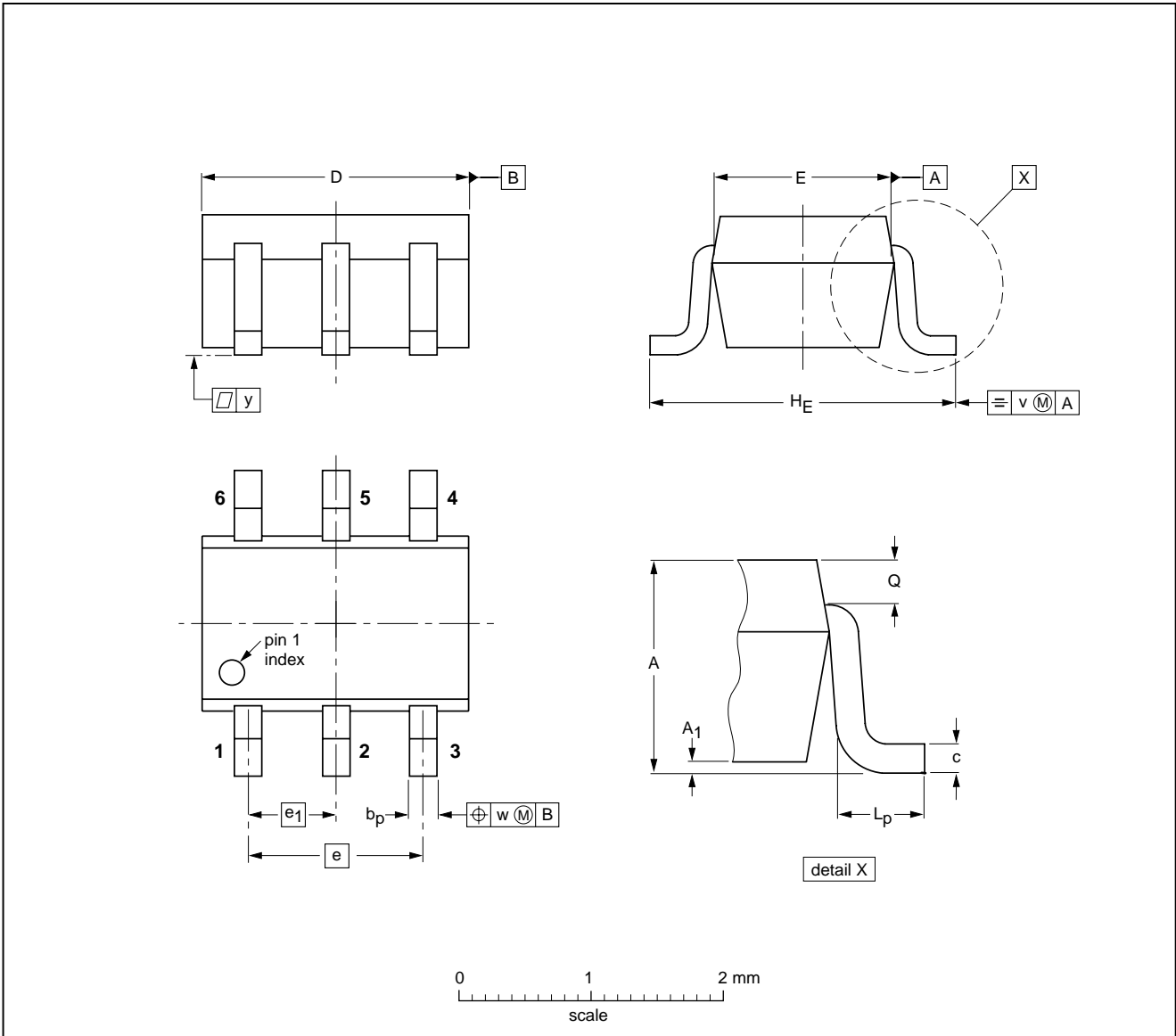

DIMENSIONS (mm are the original dimensions)

UNIT	A	A <sub>1</sub> max	b <sub>p</sub>	c	D	E	e	e <sub>1</sub>	H <sub>E</sub>	L <sub>p</sub>	Q	v	w	y
mm	1.1 0.8	0.1	0.30 0.20	0.25 0.10	2.2 1.8	1.35 1.15	1.3	0.65	2.2 2.0	0.45 0.15	0.25 0.15	0.2	0.2	0.1

OUTLINE VERSION	REFERENCES				EUROPEAN PROJECTION	ISSUE DATE
	IEC	JEDEC	EIAJ			
SOT363			SC-88			97-02-28



## MMIC wideband amplifier

BGA2771

## DATA SHEET STATUS

DATA SHEET STATUS <sup>(1)</sup>	PRODUCT STATUS <sup>(2)</sup>	DEFINITIONS
Objective data	Development	This data sheet contains data from the objective specification for product development. Philips Semiconductors reserves the right to change the specification in any manner without notice.
Preliminary data	Qualification	This data sheet contains data from the preliminary specification. Supplementary data will be published at a later date. Philips Semiconductors reserves the right to change the specification without notice, in order to improve the design and supply the best possible product.
Product data	Production	This data sheet contains data from the product specification. Philips Semiconductors reserves the right to make changes at any time in order to improve the design, manufacturing and supply. Changes will be communicated according to the Customer Product/Process Change Notification (CPCN) procedure SNW-SQ-650A.

## Notes

1. Please consult the most recently issued data sheet before initiating or completing a design.
2. The product status of the device(s) described in this data sheet may have changed since this data sheet was published. The latest information is available on the Internet at URL <http://www.semiconductors.philips.com>.

## DEFINITIONS

**Short-form specification** — The data in a short-form specification is extracted from a full data sheet with the same type number and title. For detailed information see the relevant data sheet or data handbook.

**Limiting values definition** — Limiting values given are in accordance with the Absolute Maximum Rating System (IEC 60134). Stress above one or more of the limiting values may cause permanent damage to the device. These are stress ratings only and operation of the device at these or at any other conditions above those given in the Characteristics sections of the specification is not implied. Exposure to limiting values for extended periods may affect device reliability.

**Application information** — Applications that are described herein for any of these products are for illustrative purposes only. Philips Semiconductors make no representation or warranty that such applications will be suitable for the specified use without further testing or modification.

## DISCLAIMERS

**Life support applications** — These products are not designed for use in life support appliances, devices, or systems where malfunction of these products can reasonably be expected to result in personal injury. Philips Semiconductors customers using or selling these products for use in such applications do so at their own risk and agree to fully indemnify Philips Semiconductors for any damages resulting from such application.

**Right to make changes** — Philips Semiconductors reserves the right to make changes, without notice, in the products, including circuits, standard cells, and/or software, described or contained herein in order to improve design and/or performance. Philips Semiconductors assumes no responsibility or liability for the use of any of these products, conveys no licence or title under any patent, copyright, or mask work right to these products, and makes no representations or warranties that these products are free from patent, copyright, or mask work right infringement, unless otherwise specified.

MMIC wideband amplifier

BGA2771

---

**NOTES**

MMIC wideband amplifier

BGA2771

---

**NOTES**

# *Philips Semiconductors – a worldwide company*

## **Contact information**

For additional information please visit <http://www.semiconductors.philips.com>. Fax: +31 40 27 24825

For sales offices addresses send e-mail to: [sales.addresses@www.semiconductors.philips.com](mailto:sales.addresses@www.semiconductors.philips.com).

© Koninklijke Philips Electronics N.V. 2002

SCA74

All rights are reserved. Reproduction in whole or in part is prohibited without the prior written consent of the copyright owner.

The information presented in this document does not form part of any quotation or contract, is believed to be accurate and reliable and may be changed without notice. No liability will be accepted by the publisher for any consequence of its use. Publication thereof does not convey nor imply any license under patent- or other industrial or intellectual property rights.

Printed in The Netherlands

613516/03/pp12

Date of release: 2002 Aug 06

Document order number: 9397 750 10017

*Let's make things better.*

**Philips  
Semiconductors**



**PHILIPS**