



## DESCRIPTION

UHF 25 GHz, low noise transistor with SiGe HBT technique, high power gain, low noise and large dynamic range. The adoption of subminiature SOT-343 package, especially suitable for high density surface patch installation, mainly for the VHF, UHF broadband high frequency low noise amplifier.

The BFG425W is available in SOT-343 package.

## ORDERING INFORMATION

Package Type	Part Number
SOT-343	BFG425W
Note	SPQ: 3,000pcs/Reel
AiT provides all RoHS Compliant Products	

## PIN DESCRIPTION

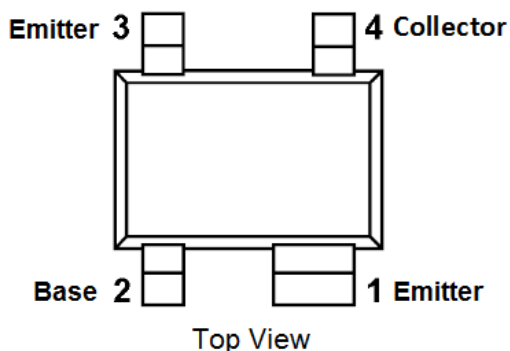

## FEATURES

- High transition frequency
- Top: -55°C~+85°C
- $N_F=1.2\text{dB}$ ,  $G_a=17\text{dB(TYP)}$   
@ $V_{CE}=2\text{V}$ ,  $I_c=25\text{mA}$ ,  $f=2\text{GHz}$
- $G_{max}=20\text{dB(Typ)}$   
@ $V_{CE}=2\text{V}$ ,  $I_c=25\text{mA}$ ,  $f=2\text{GHz}$
- Available in SOT-343 package

## APPLICATIONS

- RF front end
- Wideband applications, e.g. analog and digital cellular telephones, cordless telephones (PHS, DECT, etc.)
- Radar detectors
- Pagers
- Satellite television tuners (SATV)
- High frequency oscillators.



## ABSOLUTE MAXIMUM RATINGS

I <sub>C</sub> , Collector-Current	30mA
P <sub>tot</sub> , Total Power Dissipation	135mW
T <sub>J</sub> , Operating Junction Temperature	150°C

Stresses above may cause permanent damage to the device. These are stress ratings only and functional operation of the device at these or any other conditions beyond those indicated in the Electrical Characteristics are not implied. Exposure to absolute maximum rating conditions for extended periods may affect device reliability.

## ELECTRICAL CHARACTERISTICS

T<sub>J</sub> = 25 °C unless otherwise specified.

Parameter	Symbol	Conditions	Min.	Typ.	Max.	Unit
Collector Base Breakdown Voltage	V <sub>(BR)CBO</sub>	I <sub>C</sub> =2.5uA , I <sub>E</sub> =0	9	-	-	V
Collector-Emitter Breakdown Voltage	V <sub>(BR)CEO</sub>	I <sub>C</sub> =1mA , I <sub>B</sub> =0	4.5	-	-	V
Emitter Base Breakdown Voltage	V <sub>(BR)EBO</sub>	I <sub>E</sub> =2.5uA , I <sub>C</sub> =0	1	-	-	V
Collector-Base Leakage Current	I <sub>CBO</sub>	I <sub>E</sub> =0 , V <sub>CB</sub> =4.5V	-	-	100	nA
DC Current Gain	h <sub>FE</sub>	V <sub>CE</sub> =2V , I <sub>C</sub> =25mA	50	100	150	-
Transition Frequency	f <sub>T</sub>	V <sub>CE</sub> =2V , I <sub>C</sub> =25mA , f=2GHz	-	25	-	GHz
Maximum Power Gain	G <sub>max</sub>	V <sub>CE</sub> =2V , I <sub>C</sub> =25mA , f=2GHz	-	20	-	dB
Insertion Power Gain	S <sub>21</sub>   <sup>2</sup>	V <sub>CE</sub> =2V , I <sub>C</sub> =25mA , f=2GHz	-	17	-	dB
Noise Figure	N <sub>F</sub>	V <sub>CE</sub> =2V , f=900MHz , S= Γ <sub>opt</sub>	-	0.8	-	dB
		V <sub>CE</sub> =2V , f=2GHz , S= Γ <sub>opt</sub>	-	1.2	-	dB
Output Power at 1 dB Gain Compression	P <sub>1dB</sub>	I <sub>O</sub> =25mA , V <sub>CE</sub> =2V , f=2GHz , Z <sub>S</sub> =Z <sub>Sopt</sub> , Z <sub>L</sub> =Z <sub>Lopt</sub>	-	12	-	dBm



## TYPICAL CHARACTERISTICS

Figure 1. Common emitter input reflection coefficient ( $S_{11}$ ); typical values.

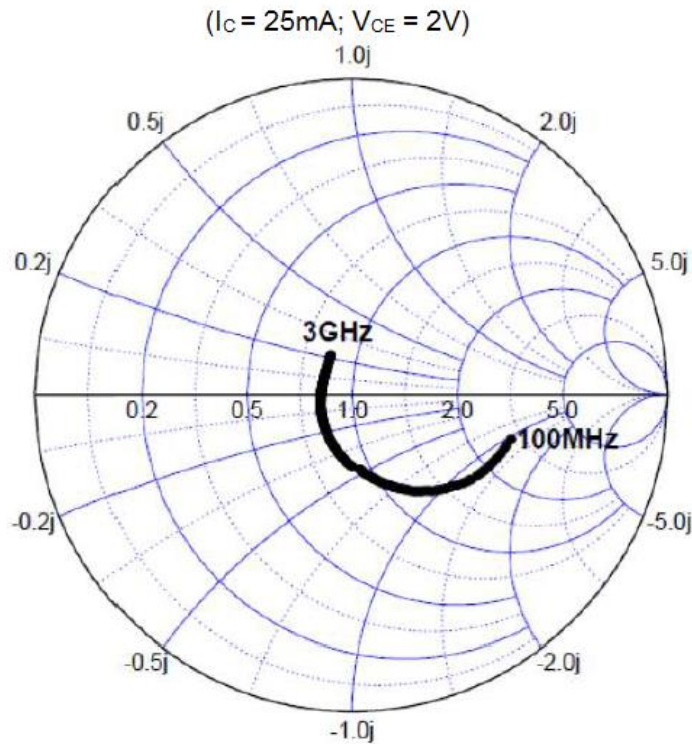

Figure 2. Common emitter forward transmission coefficient ( $S_{21}$ ); typical values.

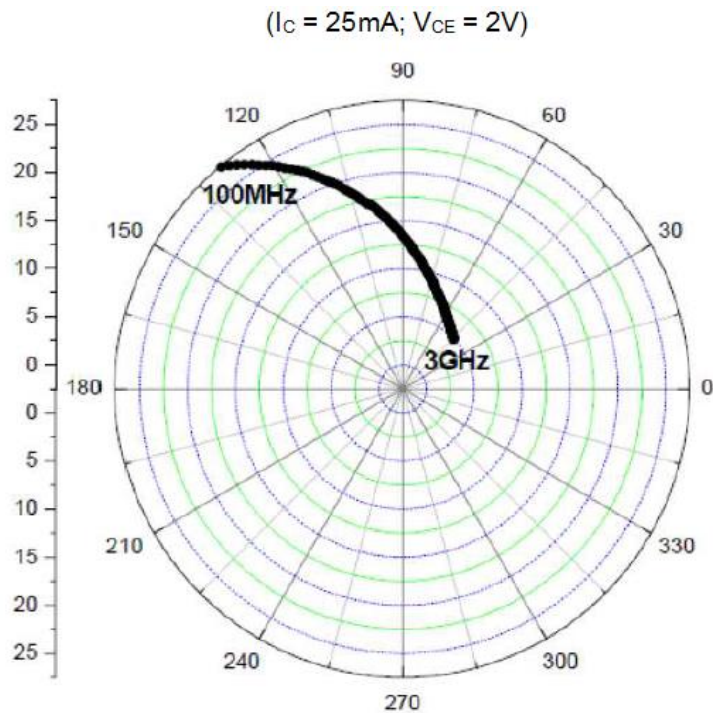



Figure 3. Common emitter reverse transmission coefficient ( $S_{12}$ ); typical values.

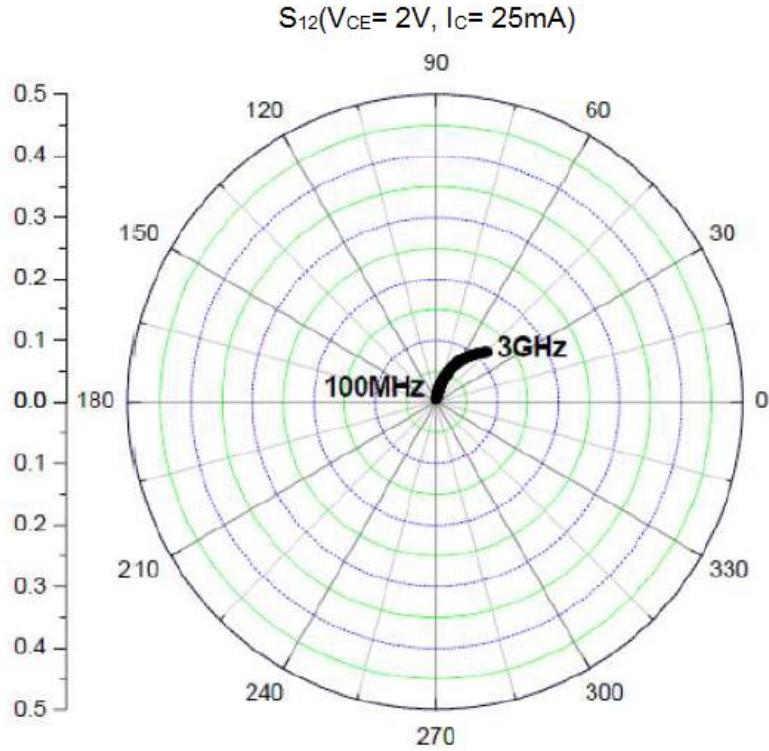
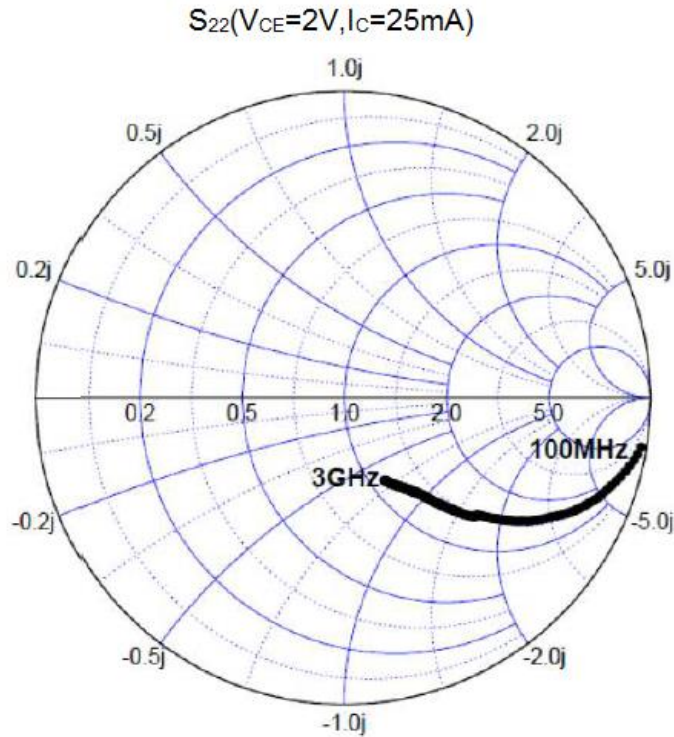

Figure 4. Common emitter output reflection coefficient ( $S_{22}$ ); typical values.





## PACKAGE INFORMATION

Dimension in SOT-343 (Unit: mm)

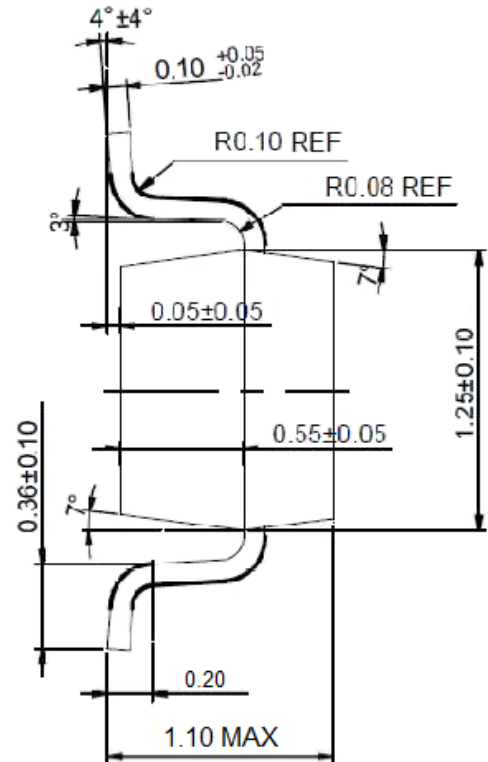
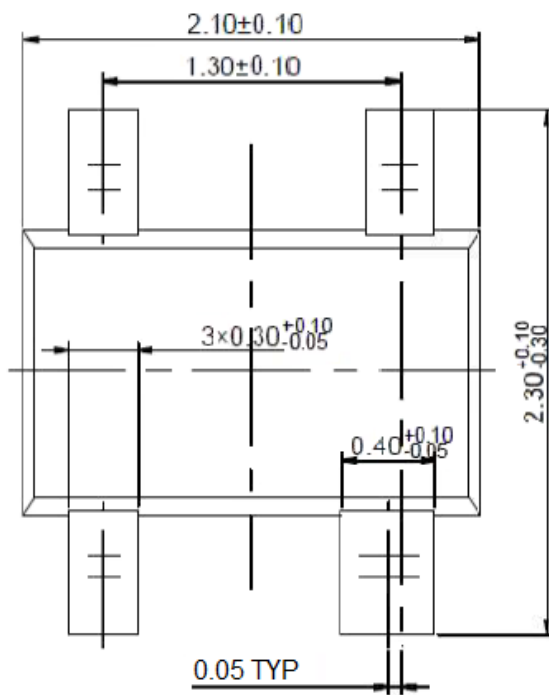



## IMPORTANT NOTICE

AiT Semiconductor Inc. (AiT) reserves the right to make changes to any its product, specifications, to discontinue any integrated circuit product or service without notice, and advises its customers to obtain the latest version of relevant information to verify, before placing orders, that the information being relied on is current.

AiT Semiconductor Inc.'s integrated circuit products are not designed, intended, authorized, or warranted to be suitable for use in life support applications, devices or systems or other critical applications. Use of AiT products in such applications is understood to be fully at the risk of the customer. As used herein may involve potential risks of death, personal injury, or severe property, or environmental damage. In order to minimize risks associated with the customer's applications, the customer should provide adequate design and operating safeguards.

AiT Semiconductor Inc. assumes to no liability to customer product design or application support. AiT warrants the performance of its products of the specifications applicable at the time of sale.