



**DONGGUAN NANJING ELECTRONICS LTD.,**  
**TO-220-3L Plastic-Encapsulate Transistors**

**BDX53/A/B/C**  
**Silicon NPN Power Transistors**

**DESCRIPTION**

- With TO-220C package
- High DC current gain
- DARLINGTON
- Complement to type BDX54/A/B/C

**APPLICATIONS**

- Power linear and switching applications
- Hammer drivers, audio amplifiers

**PINNING**

PIN	DESCRIPTION
1	Base
2	Collector; connected to mounting base
3	Emitter

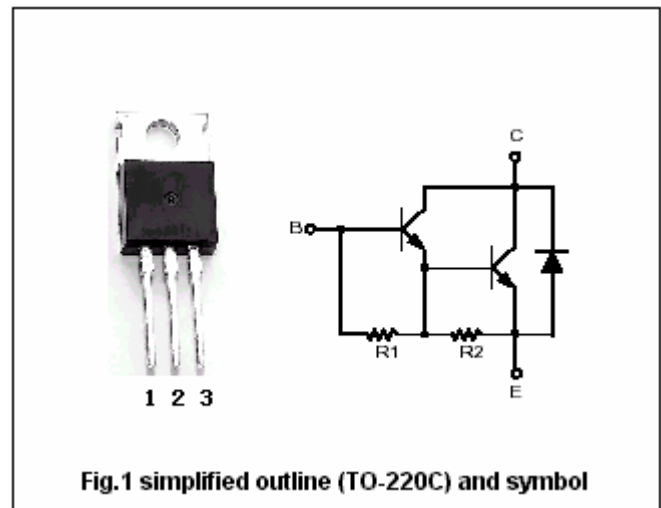

**Absolute maximum ratings(Ta=25 )**

SYMBOL	PARAMETER	CONDITIONS	VALUE	UNIT	
V <sub>CBO</sub>	Collector-base voltage	Open emitter	BDX53	45	V
			BDX53A	60	
			BDX53B	80	
			BDX53C	100	
V <sub>CEO</sub>	Collector-emitter voltage	Open base	BDX53	45	V
			BDX53A	60	
			BDX53B	80	
			BDX53C	100	
V <sub>EBO</sub>	Emitter-base voltage	Open collector	5	V	
I <sub>C</sub>	Collector current-DC		8	A	
I <sub>CM</sub>	Collector current-Pulse		12	A	
I <sub>B</sub>	Base current		0.2	A	
P <sub>C</sub>	Collector power dissipation	T <sub>C</sub> =25	60	W	
T <sub>j</sub>	Junction temperature		150		
T <sub>stg</sub>	Storage temperature		-65~150		

**THERMAL CHARACTERISTICS**

SYMBOL	PARAMETER	MAX	UNIT
R <sub>th j-c</sub>	Thermal resistance junction to case	2.08	/W

# BDX53/A/B/C

## Silicon NPN Power Transistors

### CHARACTERISTICS

T<sub>j</sub>=25 unless otherwise specified

SYMBOL	PARAMETER	CONDITIONS	MIN	TYP.	MAX	UNIT	
V <sub>CEO(SUS)</sub>	Collector-emitter sustaining voltage	BDX53	45			V	
		BDX53A	60				
		BDX53B	80				
		BDX53C	100				
V <sub>CEsat</sub>	Collector-emitter saturation voltage	I <sub>C</sub> =3A, I <sub>B</sub> =12mA			2.0	V	
V <sub>BE sat</sub>	Base-emitter saturation voltage	I <sub>C</sub> =3A, I <sub>B</sub> =12mA			2.5	V	
I <sub>CBO</sub>	Collector cut-off current	BDX53	V <sub>CB</sub> =45V, I <sub>E</sub> =0			0.2	mA
		BDX53A	V <sub>CB</sub> =60V, I <sub>E</sub> =0				
		BDX53B	V <sub>CB</sub> =80V, I <sub>E</sub> =0				
		BDX53C	V <sub>CB</sub> =100V, I <sub>E</sub> =0				
I <sub>CEO</sub>	Collector cut-off current	BDX53	V <sub>CE</sub> =22V, I <sub>B</sub> =0			0.5	mA
		BDX53A	V <sub>CE</sub> =30V, I <sub>B</sub> =0				
		BDX53B	V <sub>CE</sub> =40V, I <sub>B</sub> =0				
		BDX53C	V <sub>CE</sub> =50V, I <sub>B</sub> =0				
I <sub>EBO</sub>	Emitter cut-off current	V <sub>EB</sub> =5V; I <sub>C</sub> =0			2.0	mA	
h <sub>FE</sub>	DC current gain	I <sub>C</sub> =3A; V <sub>CE</sub> =3V	750				
V <sub>F-1</sub>	Forward diode voltage	I <sub>F</sub> =3A		1.8	2.5	V	
V <sub>F-2</sub>	Forward diode voltage	I <sub>F</sub> =8A		2.5		V	

# BDX53/A/B/C

## Silicon NPN Power Transistors

### PACKAGE OUTLINE

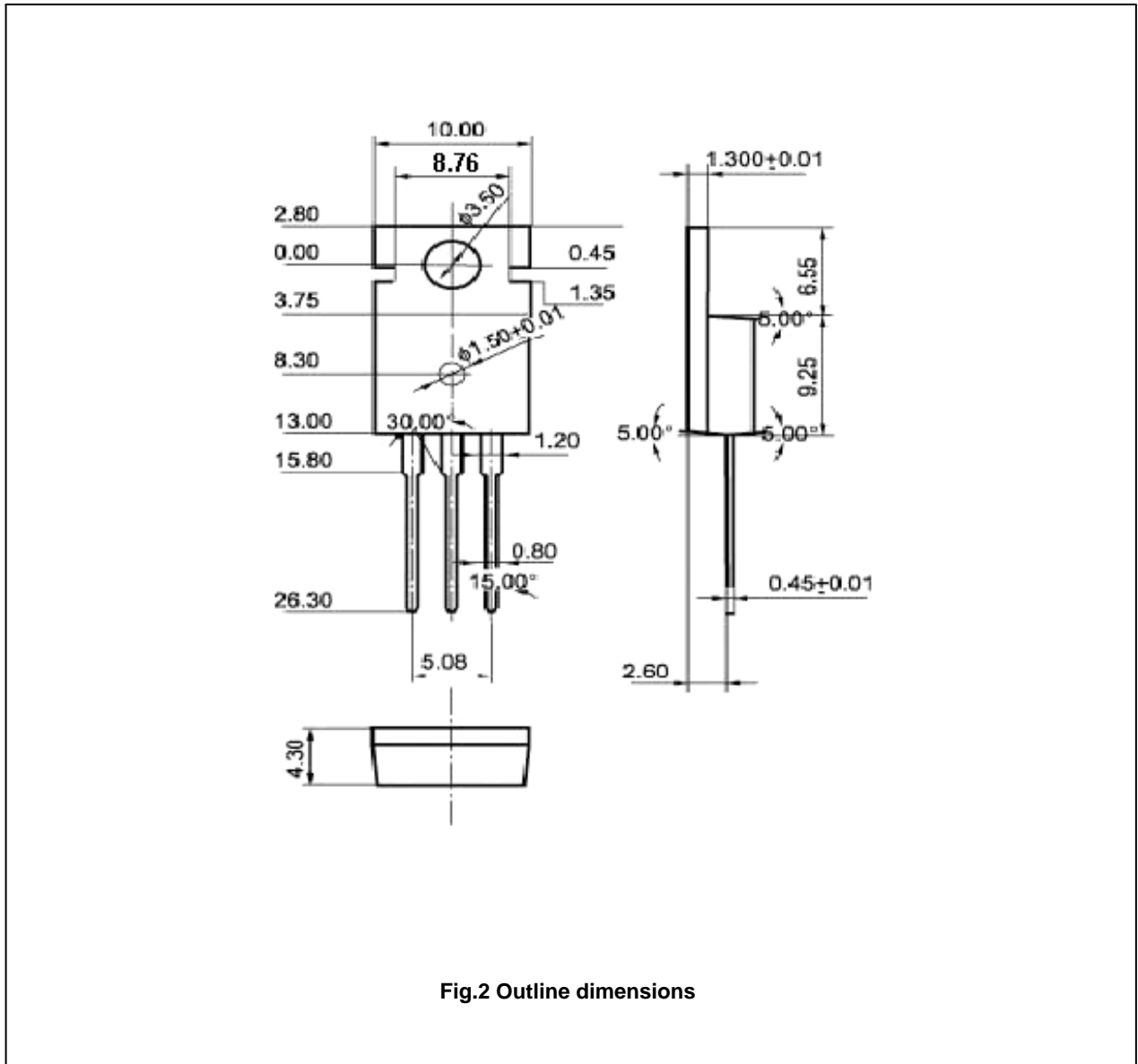

Fig.2 Outline dimensions