

Silicon NPN Power Transistors

BD243/A/B/C

DESCRIPTION

- With TO-220C package
- Complement to type BD244/A/B/C

APPLICATIONS

- For medium power linear and switching applications

PINNING

PIN	DESCRIPTION
1	Base
2	Collector;connected to mounting base
3	Emitter

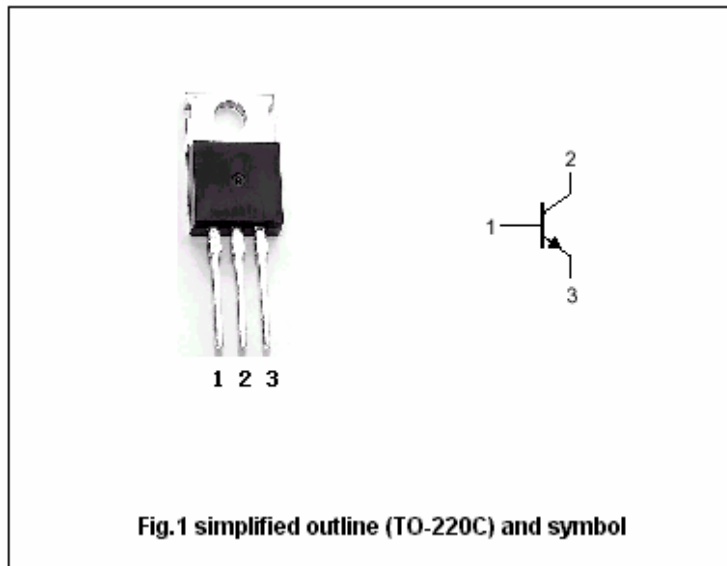

Absolute maximum ratings (Ta=25°C)

SYMBOL	PARAMETER	CONDITIONS	VALUE	UNIT
V _{CBO}	Collector-base voltage	BD243	45	V
		BD243A	60	
		BD243B	80	
		BD243C	100	
V _{CEO}	Collector-emitter voltage	BD243	45	V
		BD243A	60	
		BD243B	80	
		BD243C	100	
V _{EBO}	Emitter-base voltage	Open collector	5	V
I _C	Collector current		6	A
I _{CM}	Collector current-peak		10	A
I _B	Base current		2	A
P _C	Collector power dissipation	T _C =25°C	65	W
T _j	Junction temperature		150	°C
T _{stg}	Storage temperature		-65~150	°C

Silicon NPN Power Transistors

BD243/A/B/C

CHARACTERISTICS

T_j=25°C unless otherwise specified

SYMBOL	PARAMETER	CONDITIONS	MIN	TYP.	MAX	UNIT	
V _{CEO(SUS)}	Collector-emitter sustaining voltage	BD243	45			V	
		BD243A	60				
		BD243B	80				
		BD243C	100				
V _{CEsat}	Collector-emitter saturation voltage	I _C =6A; I _B =1 A			1.5	V	
V _{BE}	Base-emitter on voltage	I _C =6A ; V _{CE} =4V			2.0	V	
I _{CEO}	Collector cut-off current	BD243/A	V _{CE} =30V; I _B =0			0.7	mA
		BD243B/C	V _{CE} =60V; I _B =0				
I _{CES}	Collector cut-off current	BD243	V _{CE} =45V; V _{BE} =0			0.4	mA
		BD243A	V _{CE} =60V; V _{BE} =0				
		BD243B	V _{CE} =80V; V _{BE} =0				
		BD243C	V _{CE} =100V; V _{BE} =0				
I _{EBO}	Emitter cut-off current	V _{EB} =5V; I _C =0			1	mA	
h _{FE-1}	DC current gain	I _C =0.3A ; V _{CE} =4V	30				
h _{FE-2}	DC current gain	I _C =3A ; V _{CE} =4V	15				

Silicon NPN Power Transistors

BD243/A/B/C

PACKAGE OUTLINE

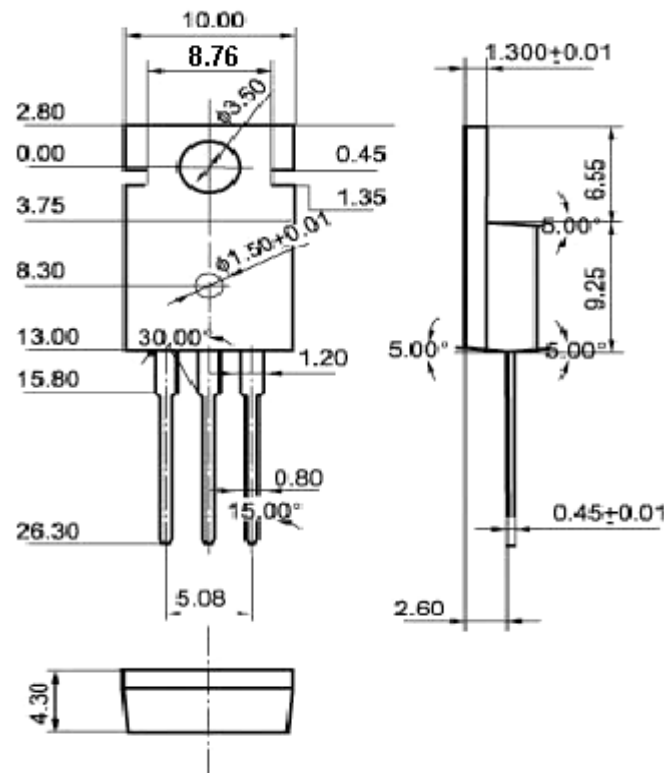

Fig.2 Outline dimensions (unindicated tolerance: ± 0.10 mm)