

## LED Driver

### Features

- Continuous output current up to 250mA with external resistor
- Supply voltage up to 24V
- Digital PWM input up to 10kHz frequency (BCR321U)
- Up to 1W power dissipation in a small SC74 package
- Negative thermal coefficient reduces output current at higher temperatures
- Easy paralleling of drivers to increase current
- PB-free (RoHS compliant) package
- Automotive qualified according to AEC Q101

### Applications

- Architectural LED lighting
- Channel letters for advertising, LED strips for decorative lighting
- Retail lighting in fridge, freezer case and vending machines
- Emergency lighting (e.g. steps lighting, exit way signs etc.)

### General Description

The BCR320U/BCR321U provide a low-cost solution for driving 0.5W LEDs with a typical LED current  $I_{LED}$  of 150mA to 200mA. Internal breakdown voltage is  $>16V$ , this is the maximum voltage that the LED driver IC can sustain when the output is directly connected to supply voltage. The BCR320U/BCR321U can be operated at supply voltages of 16V or higher, by regarding the voltage drop of the LED load, which reduces the supply voltage to the maximum output voltage of the driver.

The enable pin (BCR320) can withstand a maximum voltage of 25 V, which can also be increased by stacking a series in front of the LED drivers, resulting in a certain voltage drop of the LEDs, reducing the voltage at the enable pin below 25V.

A digital input pin (BCR321U) allows dimming via a Microcontroller with frequencies of up to 10 kHz.

A reduction of the output current at higher temperatures is the result of the negative temperature coefficient of 0.2 %/K. of the LED drivers.

With no need for additional external components like inductors, capacitors and free wheeling diodes, the BCR320U/BCR321U LED drivers are a cost-efficient and PCB-area saving solution for driving 0.5W LEDs.

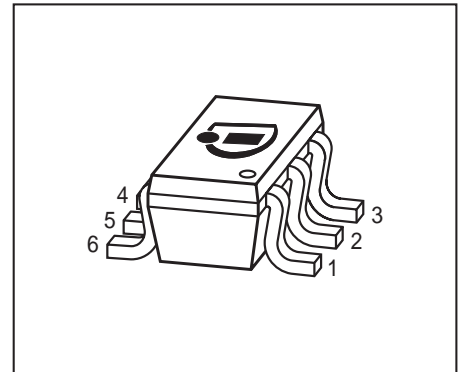

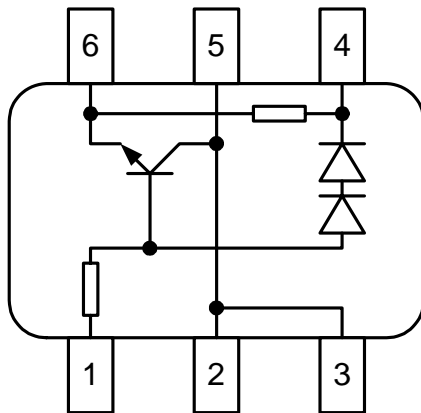
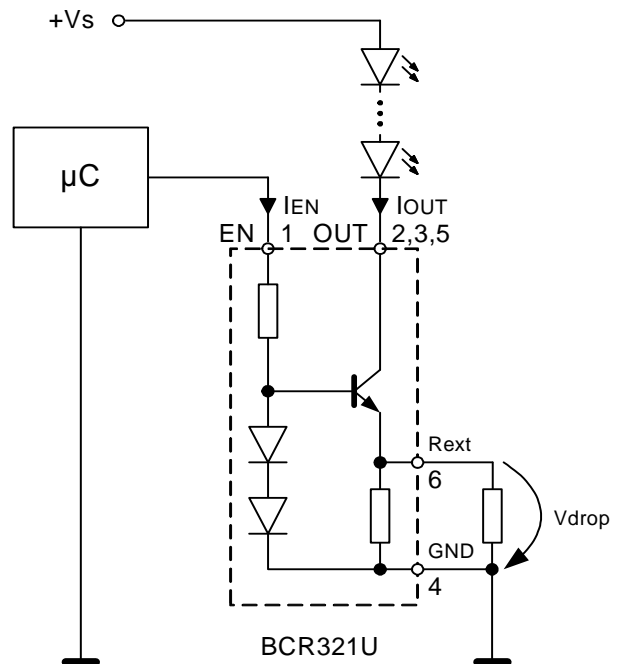
**Pin Configuration**

**Typical Application**

Type	Marking	Pin Configuration				Package
BCR320U	30	1 = EN	2;3;5 =	4 = GND	6 = R <sub>ext</sub>	SC74
BCR321U	31		OUT			SC74

**Maximum Ratings**

Parameter	Symbol	Value	Unit
Enable voltage	V <sub>EN</sub>		V
BCR320U		25	
BCR321U		4.5	
Output current	I <sub>out</sub>	300	mA
Output voltage	V <sub>out</sub>	16	V
Reverse voltage between all terminals	V <sub>R</sub>	0.5	
Total power dissipation, T <sub>S</sub> = 102 °C	P <sub>tot</sub>	1000	mW
Junction temperature	T <sub>j</sub>	150	°C
Storage temperature	T <sub>stg</sub>	-65 ... 150	

**Thermal Resistance**

Parameter	Symbol	Value	Unit
Junction - soldering point <sup>1)</sup>	R <sub>thJS</sub>	50	K/W

<sup>1)</sup>For calculation of R<sub>thJA</sub> please refer to Application Note Thermal Resistance

**Electrical Characteristics** at  $T_A=25^\circ\text{C}$ , unless otherwise specified

Parameter	Symbol	Values			Unit
		min.	typ.	max.	
<b>Characteristics</b>					
Collector-emitter breakdown voltage $I_C = 1 \text{ mA}$ , $I_B = 0$	$V_{BR(CEO)}$	16	-	-	V
Enable current $V_{EN} = 12$ , BCR320U $V_{EN} = 3.3$ , BCR321U	$I_{EN}$	-	1.2	-	mA
DC current gain $I_C = 50 \text{ mA}$ , $V_{CE} = 1 \text{ V}$	$h_{FE}$	200	350	500	-
Internal resistor $I_{Rint} = 10 \text{ mA}$	$R_{int}$	65	90	105	$\Omega$
Bias resistor BCR320U BCR321U	$R_B$	-	10	-	k $\Omega$
Output current $V_{out} = 1.4 \text{ V}$ , $V_{EN} = 12 \text{ V}$ , BCR320U $V_{out} = 1.4 \text{ V}$ , $V_{EN} = 3.3 \text{ V}$ , BCR321U $V_{out} = 1.4 \text{ V}$ , $V_{EN} = 12 \text{ V}$ , $R_{EXT} = 3 \Omega$ , BCR320U $V_{out} = 1.4 \text{ V}$ , $V_{EN} = 3.3$ , $R_{EXT} = 3 \Omega$ , BCR321U	$I_{out}$	8	10	12	mA
Voltage drop ( $V_{Rext}$ ) $I_C = 10 \text{ mA}$	$V_{drop}$	0.85	0.95	1.05	V

**DC Characteristics with stabilized LED load**

Lowest sufficient supply voltage overhead $I_{out} > 18\text{mA}$	$V_{Smin}$	-	1.4	-	V
Output current change versus $T_A$ $V_{EN} = 12 \text{ V}$ ; $V_{out} > 2.0 \text{ V}$ , BCR320U $V_{EN} = 3.3 \text{ V}$ ; $V_{out} > 2.0 \text{ V}$ , BCR321U	$\Delta I_{out}/I_{out}$	-	-0.2	-	%/K
Output current change versus $V_S$ $V_{EN} = 12 \text{ V}$ ; $V_{out} > 2.0 \text{ V}$ , BCR320U $V_{EN} = 3.3 \text{ V}$ ; $V_{out} > 2.0 \text{ V}$ , BCR321U	$\Delta I_{out}/I_{out}$	-	1	-	%/V

**Total power dissipation  $P_{tot} = f(T_S)$**

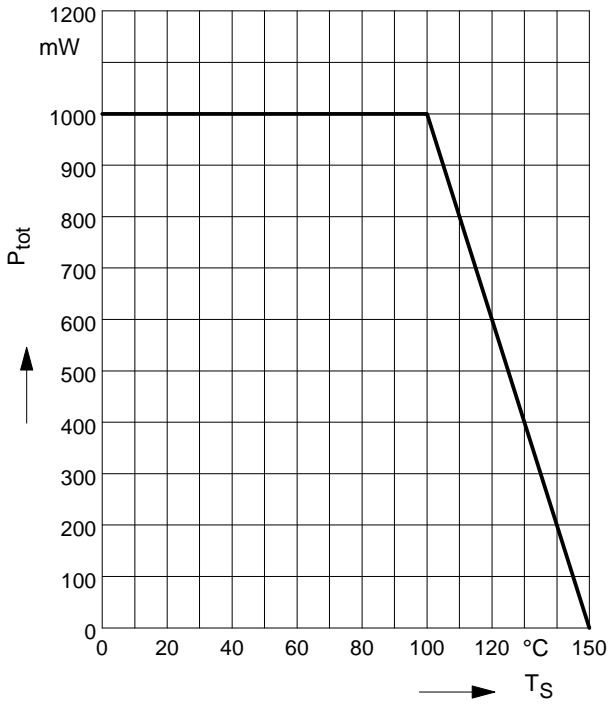

**Permissible Pulse Load  $R_{thJS} = f(t_p)$**

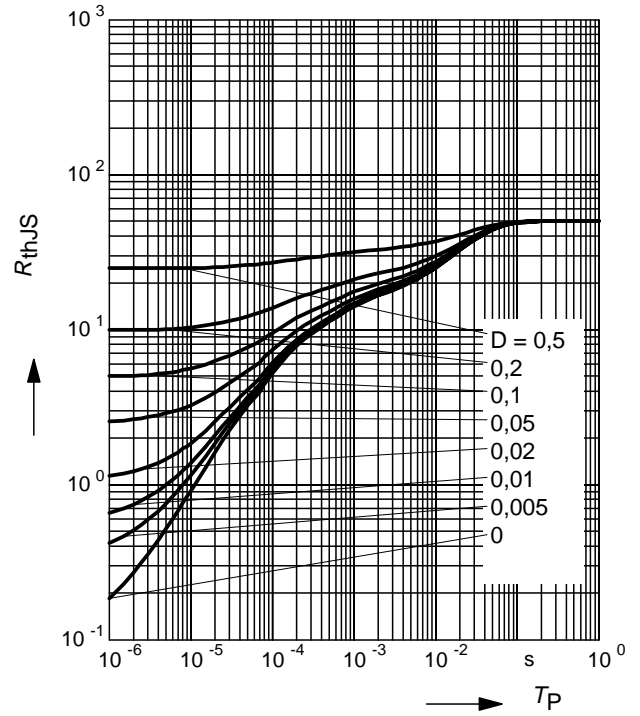

**Permissible Pulse Load**

$P_{totmax} / P_{totDC} = f(t_p)$

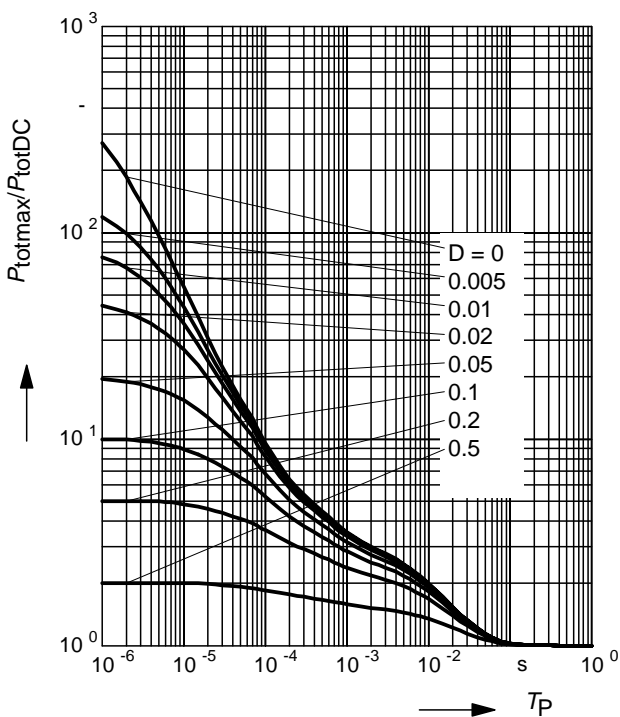

**BCR320U: Output current versus  $V_{out}$**

$I_{out} = f(V_{out}); V_{EN} = 12\text{ V};$   
 $R_{ext} = \text{Parameter}$

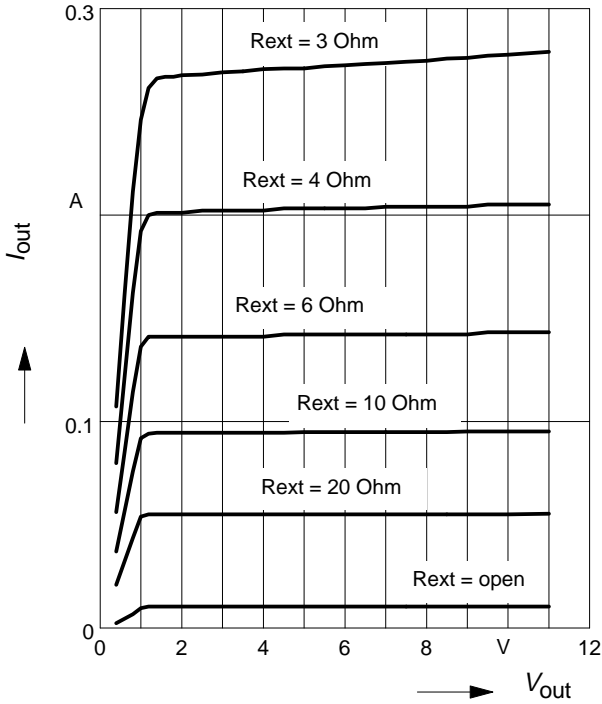

**BCR320U: Output current versus  $R_{ext}$**

$I_{out} = f(R_{ext}); V_{EN} = 12\text{ V};$   
 $V_{out} = \text{Parameter}$

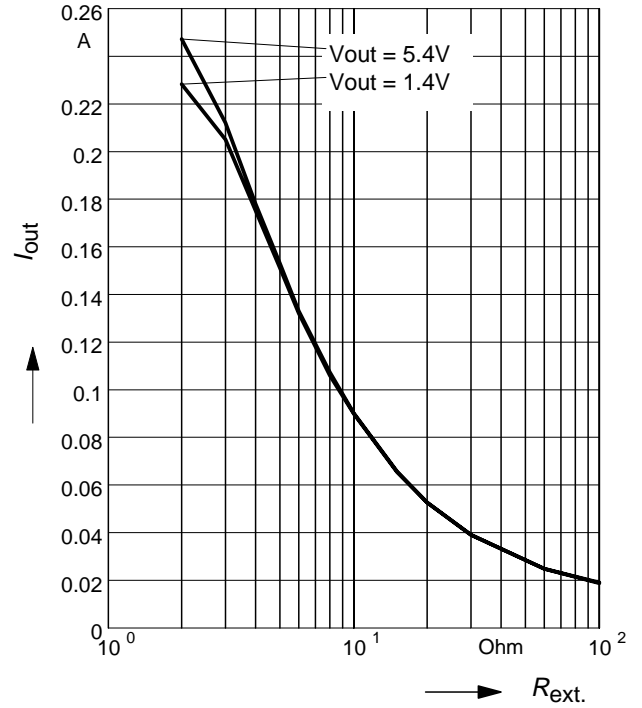

**BCR320U: Output current versus  $V_{out}$**

$I_{out} = f(V_S); V_{EN} = 12\text{ V}; R_{ext} = \text{open};$   
 $T_A = \text{Parameter}$

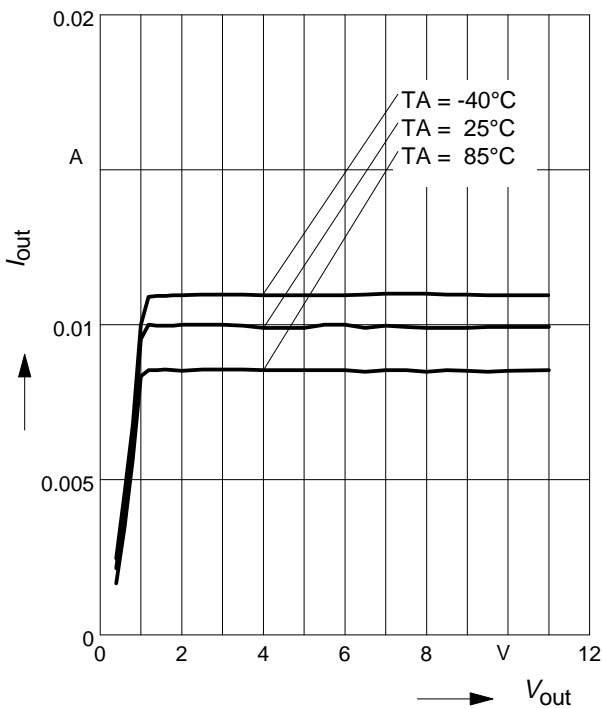

**BCR320U: Output current versus  $V_{out}$**

$I_{out} = f(V_S); V_{EN} = 12\text{ V}; R_{ext} = 20\text{ Ohm};$   
 $T_A = \text{Parameter}$

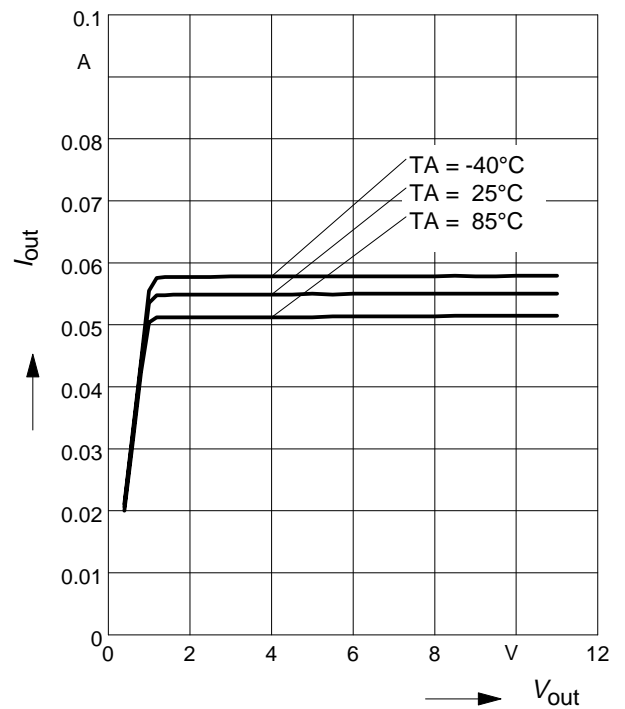

**BCR320U: Output current versus  $V_{out}$**

$I_{out} = f(V_S)$ ;  $V_{EN} = 12\text{ V}$ ;  $R_{ext} = 3\text{ Ohm}$ ;  
 $T_A = \text{Parameter}$

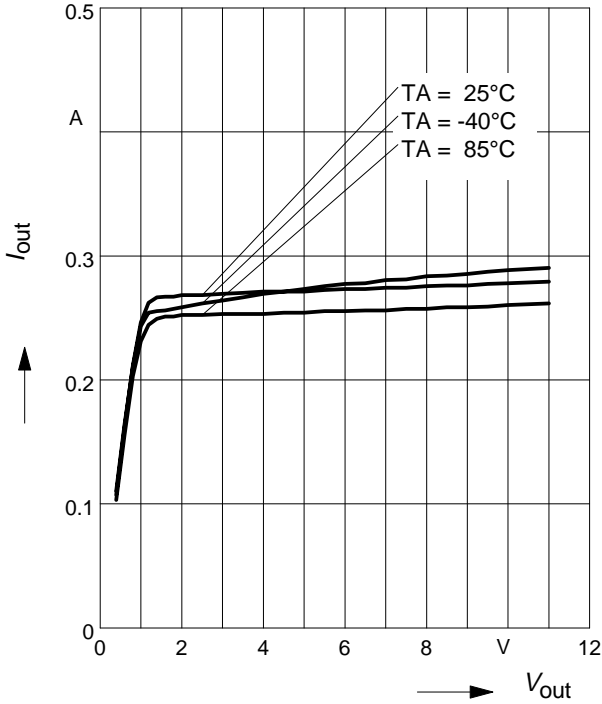

**BCR320U: Output current versus  $V_{EN}$**

$I_{out} = f(V_{EN})$ ;  $V_{out} = 2.0\text{ V}$ ;  $R_{ext} = \text{open}$ ;  
 $T_A = \text{Parameter}$

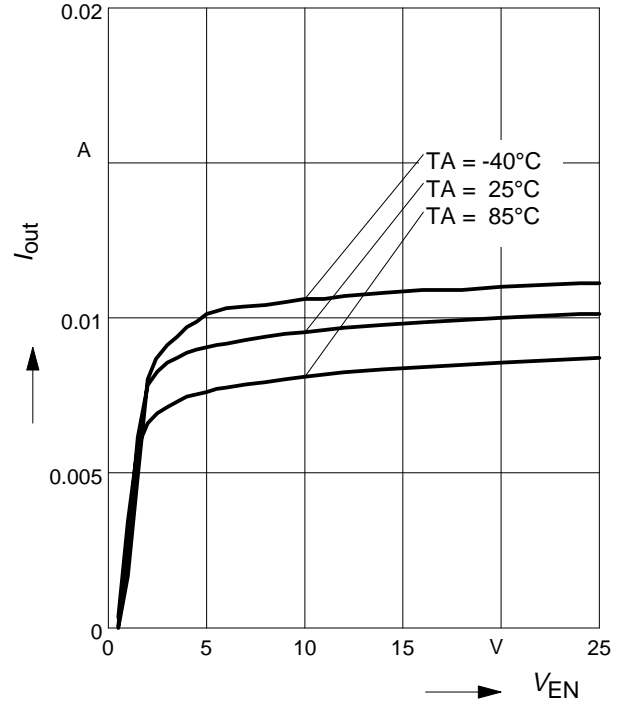

**BCR320U: Output current versus  $V_{EN}$**

$I_{out} = f(V_{EN})$ ;  $V_{out} = 2.0\text{ V}$ ;  $R_{ext} = 20\text{ Ohm}$ ;  
 $T_A = \text{Parameter}$

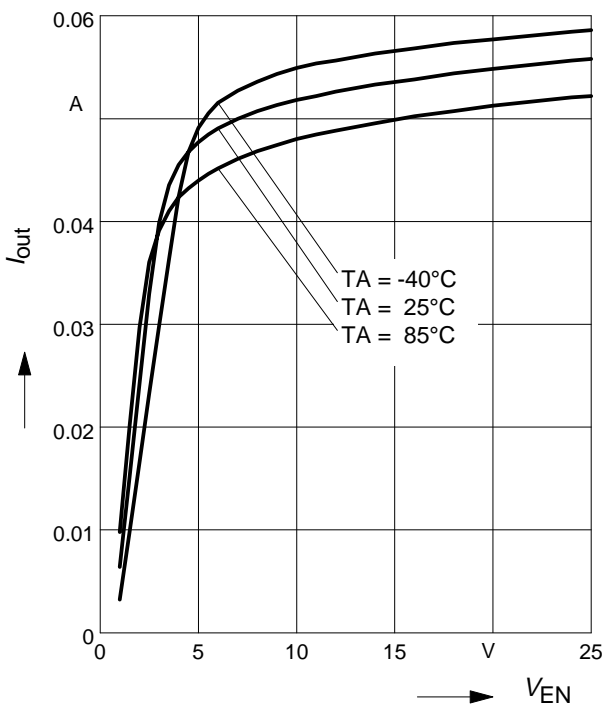

**BCR320U: Output current versus  $V_{EN}$**

$I_{out} = f(V_{EN})$ ;  $V_{out} = 2.0\text{ V}$ ;  $R_{ext} = 3\text{ Ohm}$ ;  
 $T_A = \text{Parameter}$

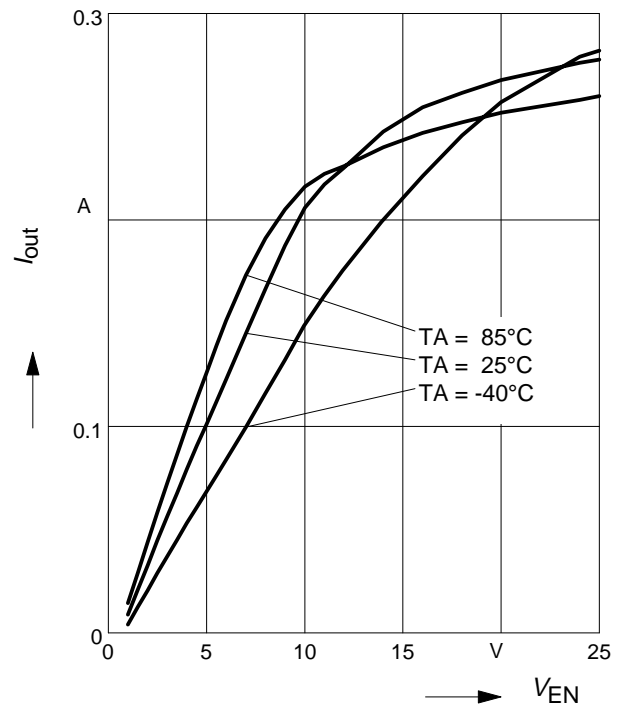

**BCR320U: Output current versus  $V_{EN}$**

$I_{out} = f(V_{EN}); V_{out} = 2.0\text{ V};$   
 $R_{ext} = \text{Parameter}$

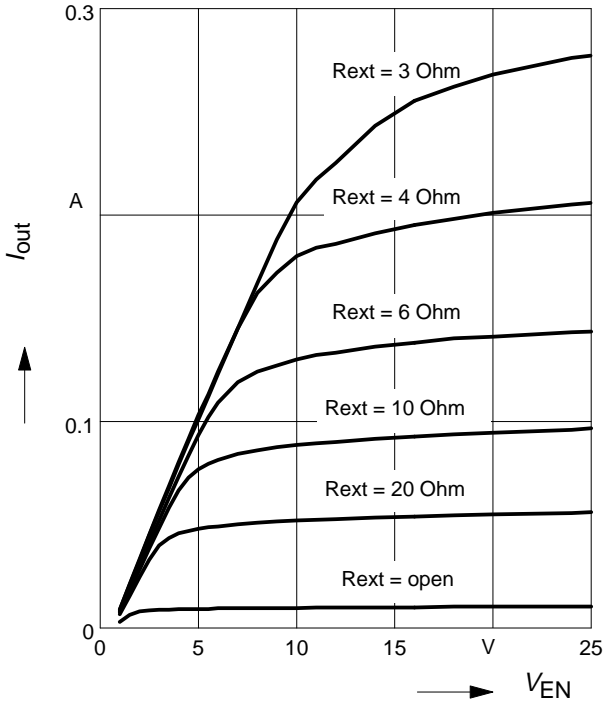

**BCR320U: Enable current versus  $V_{EN}$**

$I_{EN} = f(V_{EN}); R_{ext} = \text{open}; I_{out} = 0;$   
 $T_A = \text{Parameter}$

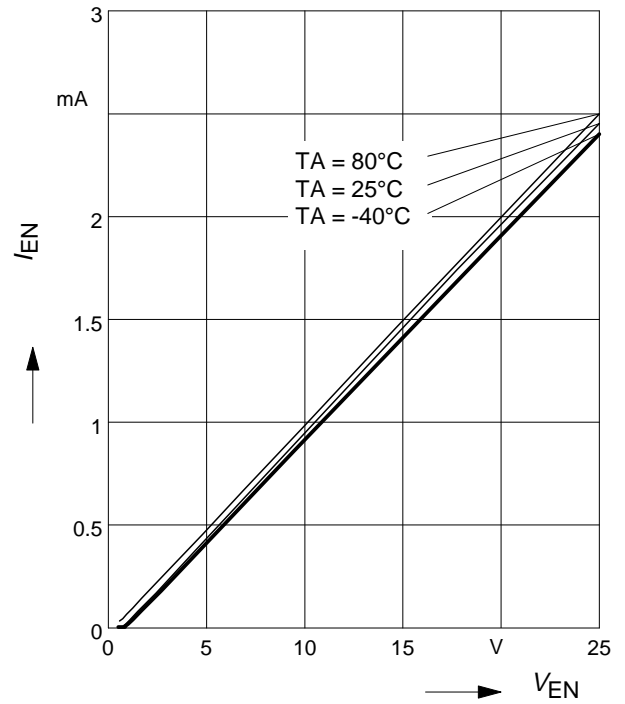

**BCR321U: Output current versus  $V_{out}$**

$I_{out} = f(V_{out}); V_{EN} = 3.3\text{ V};$   
 $R_{ext} = \text{Parameter}$

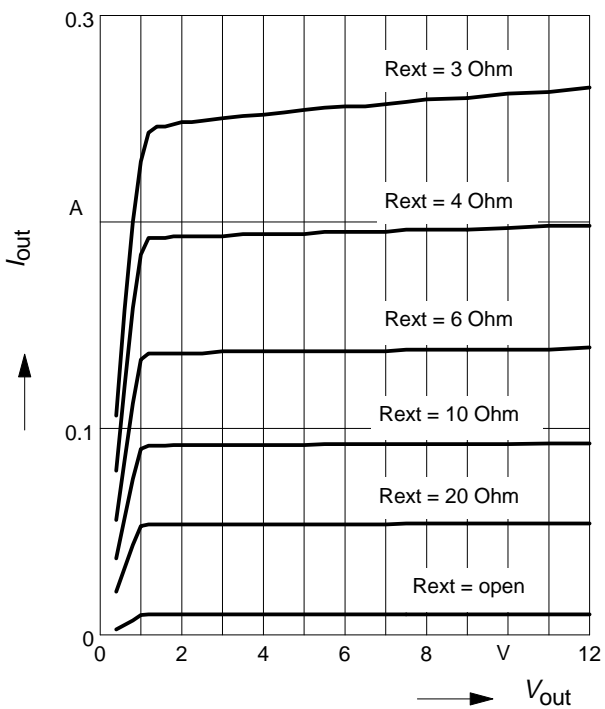

**BCR321U: Output current versus  $R_{ext}$**

$I_{out} = f(R_{ext}); V_{EN} = 3.3\text{ V};$   
 $V_{out} = \text{Parameter}$

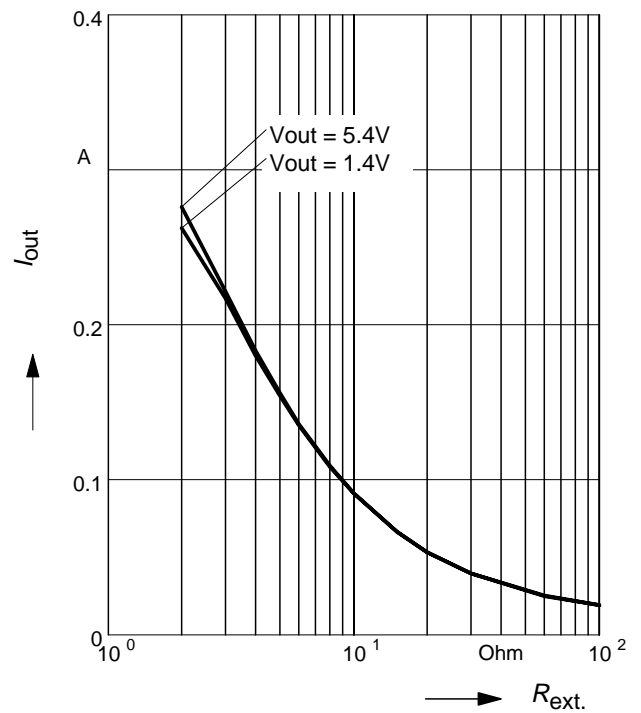

**BCR321U: Output current versus  $V_{out}$**

$I_{out} = f(V_S)$ ;  $V_{EN} = 3.3\text{ V}$ ;  $R_{ext} = \text{open}$ ;  
 $T_A = \text{Parameter}$

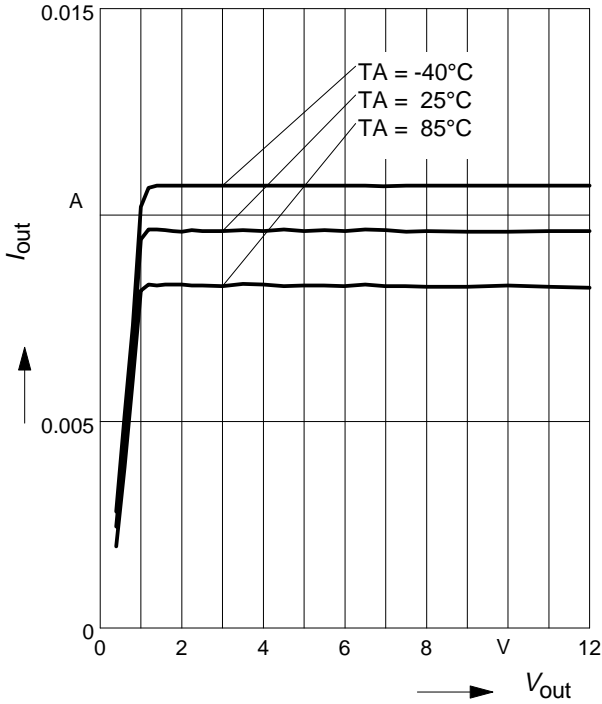

**BCR321U: Output current versus  $V_{out}$**

$I_{out} = f(V_S)$ ;  $V_{EN} = 3.3\text{ V}$ ;  $R_{ext} = 20\text{ Ohm}$ ;  
 $T_A = \text{Parameter}$

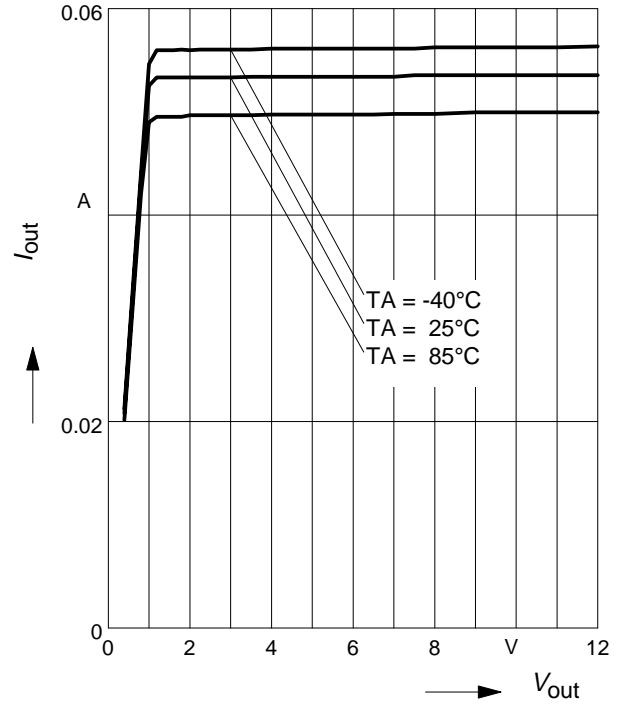

**BCR321U: Output current versus  $V_{out}$**

$I_{out} = f(V_S)$ ;  $V_{EN} = 3.3\text{ V}$ ;  $R_{ext} = 3\text{ Ohm}$ ;  
 $T_A = \text{Parameter}$

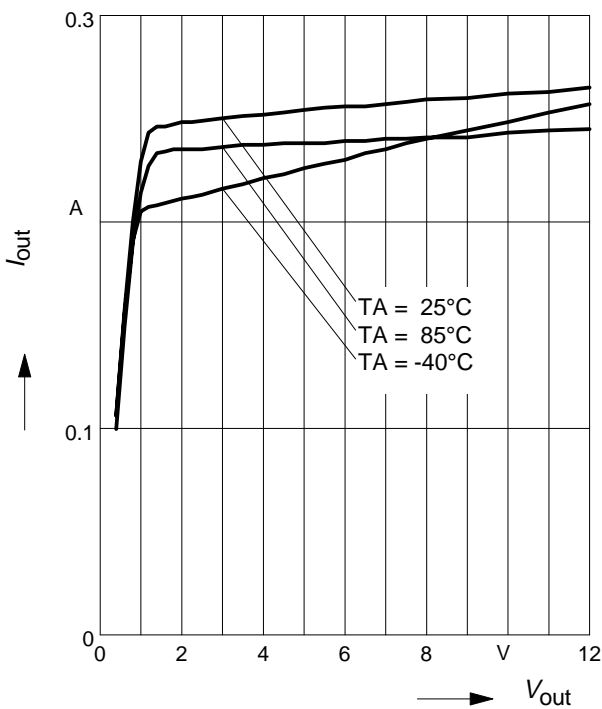

**BCR321U: Output current versus  $V_{EN}$**

$I_{out} = f(V_{EN})$ ;  $V_{out} = 2.0\text{ V}$ ;  $R_{ext} = \text{open}$ ;  
 $T_A = \text{Parameter}$

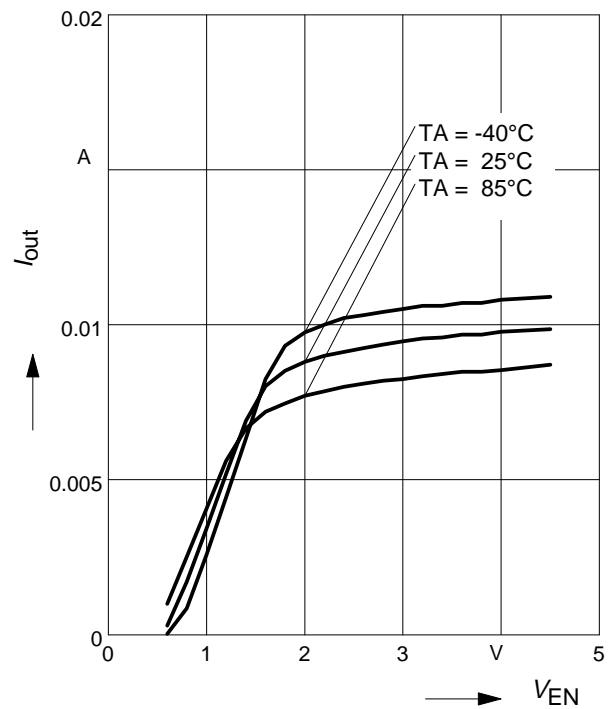



**BCR321U: Output current versus  $V_{EN}$**

$I_{out} = f(V_{EN}); V_{out} = 2.0\text{ V}; R_{ext} = 20\text{ Ohm}; T_A = \text{Parameter}$

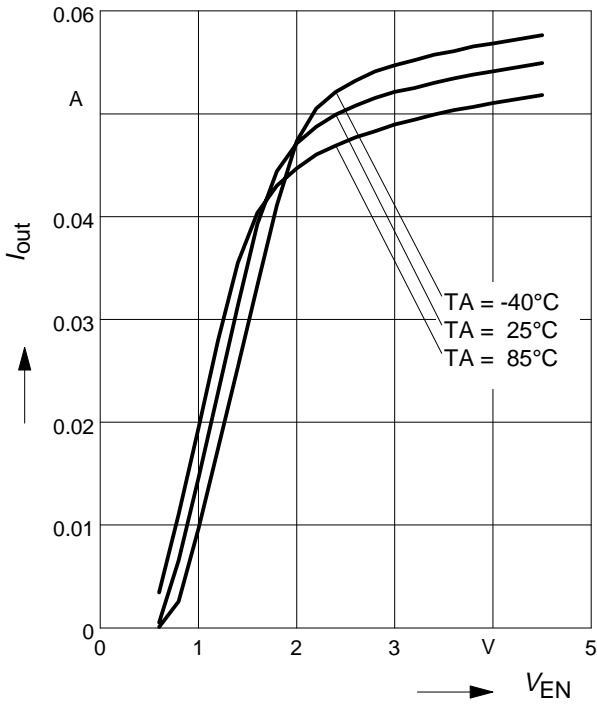

**BCR321U: Output current versus  $V_{EN}$**

$I_{out} = f(V_{EN}); V_{out} = 2.0\text{ V}; R_{ext} = 3\text{ Ohm}; T_A = \text{Parameter}$

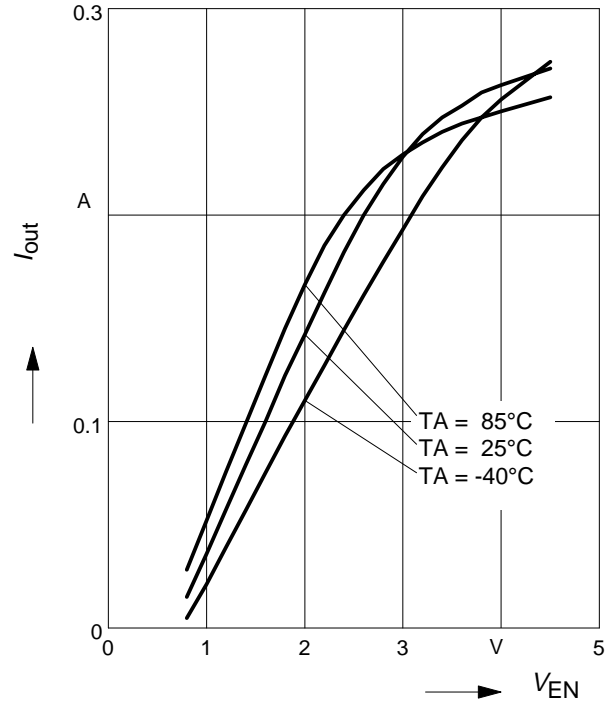

**BCR321U: Output current versus  $V_{EN}$**

$I_{out} = f(V_{EN}); V_S = 3.3\text{ V}; R_{ext} = \text{Parameter}$

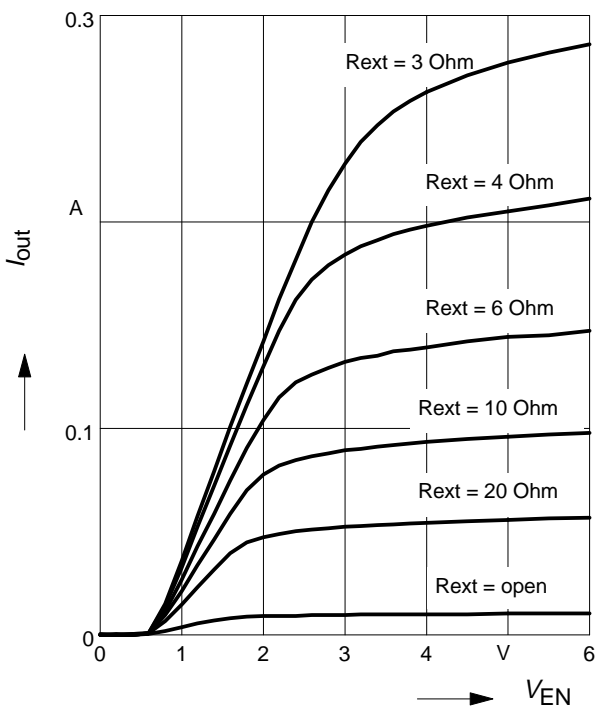

**BCR321U: Enable current versus  $V_{EN}$**

$I_{EN} = f(V_{EN}); R_{ext} = \text{open}; I_{out} = 0; T_A = \text{Parameter}$

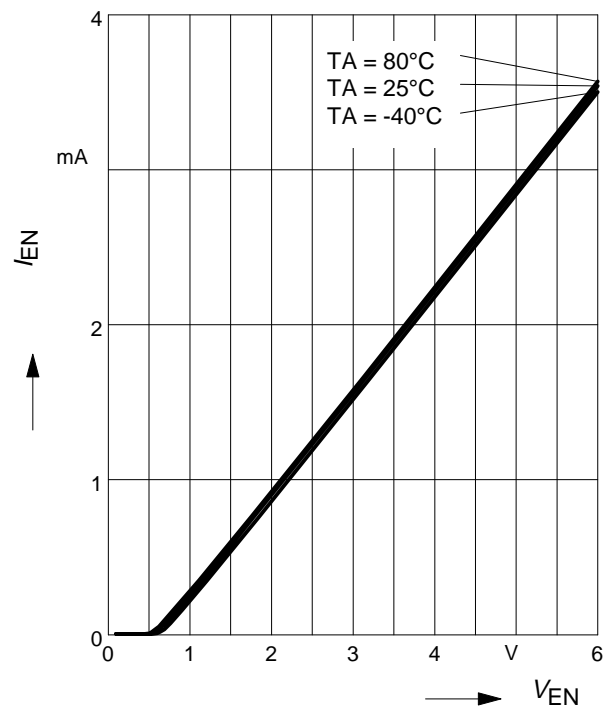

**Application circuit:**  
Enabling / PWM by micro controller

**Application circuit:**  
Enabling by connecting to Vs

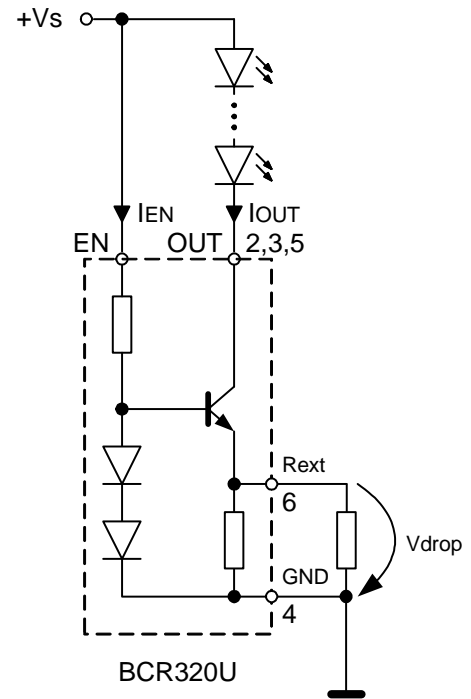
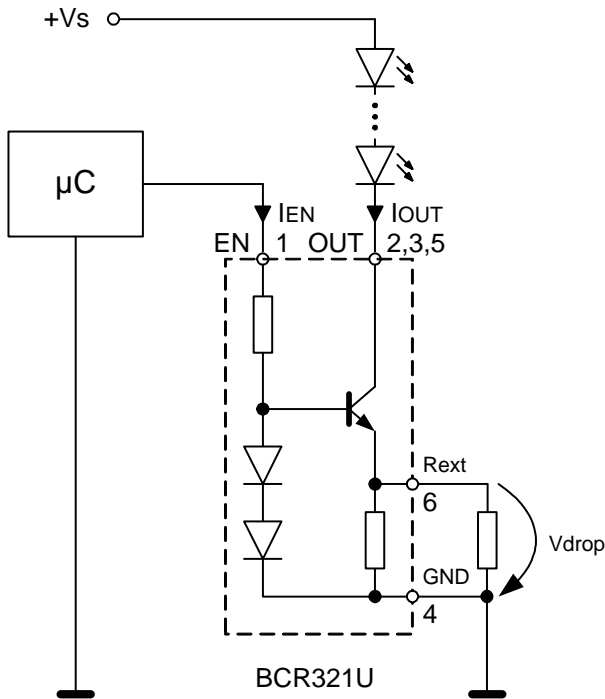

### Application hints

BCR320U / BCR321U serve as an easy to use constant current sources for LEDs. In stand alone application an external resistor can be connected to adjust the current from 10 mA to 250 mA.  $R_{ext}$  can be determined by using the diagram 'Output current versus external resistor'. Please take into account that the resulting output currents will be slightly lower due to the self heating of the component and the negative thermal coefficient.

Please visit our web site for application notes: [www.infineon.com/lowcostledriver](http://www.infineon.com/lowcostledriver) for up-to-date application information

Package Outline

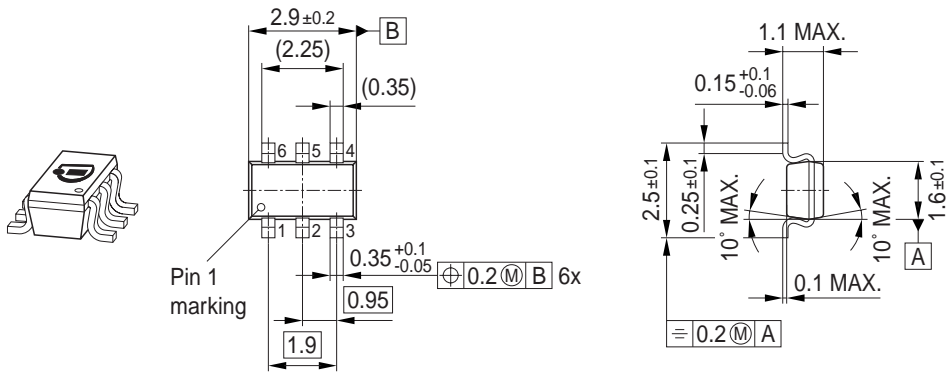

Foot Print

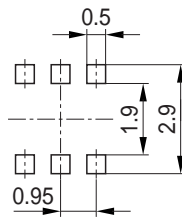

Marking Layout (Example)

Small variations in positioning of Date code, Type code and Manufacture are possible.

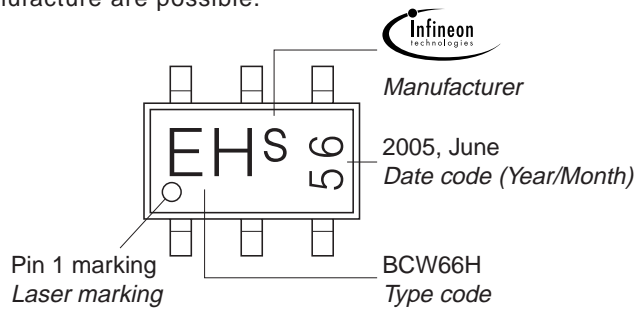

Standard Packing

Reel  $\varnothing$ 180 mm = 3.000 Pieces/Reel  
 Reel  $\varnothing$ 330 mm = 10.000 Pieces/Reel

For symmetric types no defined Pin 1 orientation in reel.

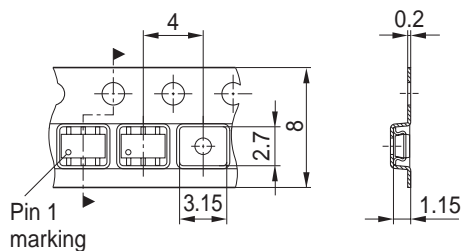

**Edition 2009-11-16**

**Published by  
Infineon Technologies AG  
81726 Munich, Germany**

**© 2009 Infineon Technologies AG  
All Rights Reserved.**

### **Legal Disclaimer**

The information given in this document shall in no event be regarded as a guarantee of conditions or characteristics. With respect to any examples or hints given herein, any typical values stated herein and/or any information regarding the application of the device, Infineon Technologies hereby disclaims any and all warranties and liabilities of any kind, including without limitation, warranties of non-infringement of intellectual property rights of any third party.

### **Information**

For further information on technology, delivery terms and conditions and prices, please contact the nearest Infineon Technologies Office ([www.infineon.com](http://www.infineon.com)).

### **Warnings**

Due to technical requirements, components may contain dangerous substances. For information on the types in question, please contact the nearest Infineon Technologies Office.

Infineon Technologies components may be used in life-support devices or systems only with the express written approval of Infineon Technologies, if a failure of such components can reasonably be expected to cause the failure of that life-support device or system or to affect the safety or effectiveness of that device or system. Life support devices or systems are intended to be implanted in the human body or to support and/or maintain and sustain and/or protect human life. If they fail, it is reasonable to assume that the health of the user or other persons may be endangered.