



DUAL 10G FABRIC INTERFACE

FEATURES

- **Highly integrated, scalable switch fabric**
- **Single-chip bandwidth of up to 40 Gbps**
- **Supports two CSIX interfaces to line side**
 - Each CSIX supports 32, 64, or 128 bits at speeds up to 166 MHz
 - HSTL Class 1 drivers
 - Optional out-of-band flow control
 - Four Egress Queues per CSIX interface
- **96-byte or 112-byte payloads**
- **Flexible fabric speedup and redundancy schemes**
 - Additional speedup to handle Cell Size + 1 byte case
 - Link failure causes graceful reduction in speed-up
- **Support for 16k Multicast Groups**
 - Full multicast group ID carries through the fabric
- **Static or dynamic configurable VOQ cell buffering**
- **Single level or hierarchical Weighted Round Robin scheduling**
- **Proven high-speed 3.125 Gbps SerDes technology**

SUMMARY OF BENEFITS

- **Guaranteed Class of Service through the system** – fabric interface chip (BCM8320) schedules based on destination, while the fabric switch chip (BCM8332) schedules based on source. QoS can be set on a source/destination basis with no interference from other channels.
- **Supports dual 10G interfaces in a single device.**
- **Excellent redundancy: all links that are used are always active.** N-1, N+1, and N≠2 redundancy modes are all supported – no software intervention is necessary.
- **Automatic link failure detection** – no software intervention is necessary.
- **Integrated SerDes provides a cost-effective and power-conscious solution.**

BCM8320 System Architecture

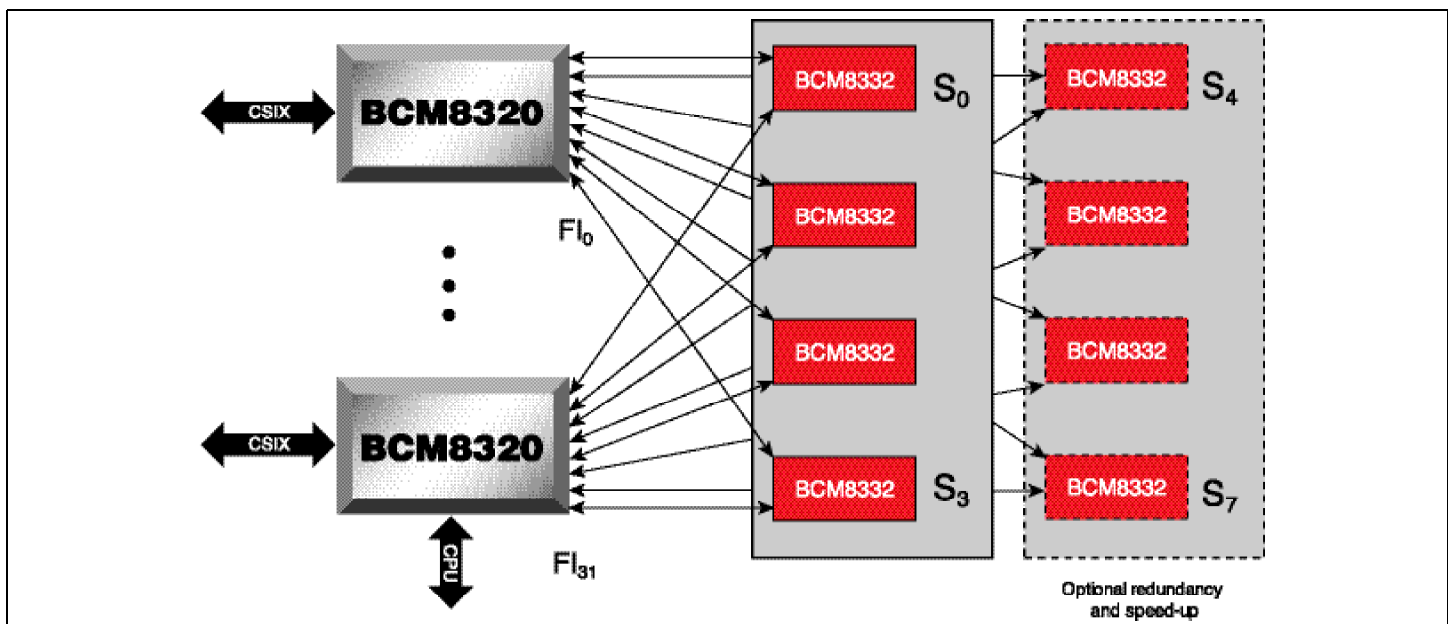

BCM8320 OVERVIEW

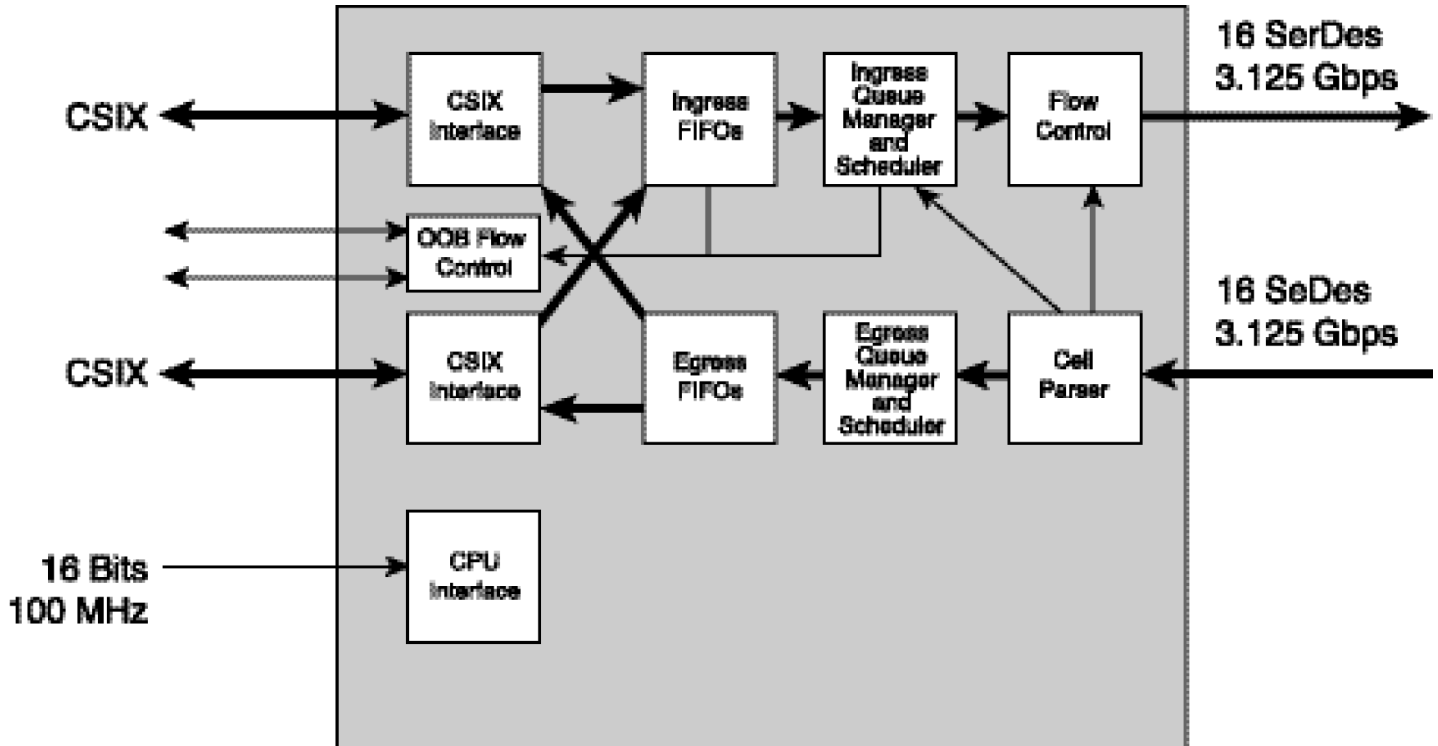

The BCM83XX switch fabric chipset is a highly integrated scalable switch fabric, consisting of the BCM8320 Fabric Interface chip and the BCM8332 Switch chip. The BCM83XX switch fabric is ideal for these applications:

- Metro packet aggregation
- Storage area networks
- Cellular packet infrastructure
- WAN core switching.

The BCM8320 supports up to two OC-192 CSIX ports per fabric interface chip. Each CSIX interface allows Traffic management devices supporting 32-bit- to 128-bit- wide interfaces to connect to the BCM83XX switch fabric.

The BCM8320 has sixteen 3.125 Gbps SerDes links to the BCM8332 devices. These links are 8b/10b encoded, providing a true 2.5 Gbps data link. The fabric can support up to a 4X speed-up if all the SerDes links are used. Unlike standard crossbar architectures, the BCM83XX switch fabric does not need speedup to maintain line rate traffic. However, a

selectable speedup is offered to handle cell size + 1 byte traffic cases as well as compensation for embedded system level headers.

The BCM83XX switch fabric provides exceptional fault tolerance and redundancy including the options of N-1, N+1 and N≠2 redundancy modes. Any link failure causes a graceful degradation in speedup and allows continuous operation during a failure or switch board replacement. Link failure detection is performed in hardware and does not require software intervention.

The BCM83XX switch fabric can support 16k multicast groups and performs all replication in the switch fabric.

The proven 3.125 Gbps integrated SerDes provides a cost- and power-effective solution while minimizing the number of backplane connections to the switch fabric.

Broadcom®, the pulse logo, and Connecting everything® are trademarks of Broadcom Corporation and/or its subsidiaries in the United States and certain other countries. All other trademarks mentioned are the property of their respective owners.

Connecting
everything®



BROADCOM CORPORATION
16215 Alton Parkway, P.O. Box 57013
Irvine, California 92619-7013

© 2004 by BROADCOM CORPORATION. All rights reserved.

8320-PB04-R 7/6/04

Phone: 949-450-8700
Fax: 949-450-8710
E-mail: info@broadcom.com
Web: www.broadcom.com