



FIVE-PORT 10/100 SWITCH WITH ON-CHIP PACKET BUFFER

FEATURES

- The highest level of silicon integration achieved for a five-port 10/100 Ethernet switch device
- Fourth generation switch on a chip
- The BCM5325 integrates:
 - Five transceivers (802.3u compliant)
 - Six media access controllers (802.x compliant)
 - 128-KB packet buffer
 - Non-blocking switch fabric
- Packet classification 802.1p QoS priority queues
- Port-based VLAN
- MII or 7-wire interface supports an additional 100FX or 100TX connection enabling a sixth user connection or uplink
- Supports up to 2K MAC addresses
- Flow control: full-duplex (802.3x) and half-duplex options supported
- Supports automatic address learning and aging
- Internal oscillator circuit
- Typical power consumption: < 1.4W
- 128-pin PQFP package

SUMMARY OF BENEFITS

- Enables a new generation of lower cost 10/100 switches in much smaller form factors
- Utilizes field-proven industry-standard 10BASE-T/100BASE-TX Fast Ethernet transceivers—lowering overall system interoperability and reliability risks
- Flexible interfaces support a wider variety of application needs—fiber for long distances or an additional 100TX port
- Sufficient address range handles all remote office, branch office and home office needs
- Port VLAN and 802.1p priority enables the switch to be designed into a wide variety of applications
- CPUs are not required to initialize and run in cost-sensitive unmanaged applications—providing true Plug and Play connectivity
- Internal oscillator circuit simplifies design and reduces overall system cost
- On-chip HP auto-MDI/MDIX feature automatically detects and corrects for crossover cables and allows direct switch-to-switch connection

Low Cost Five-Port 10/100 Stand-alone Switch



OVERVIEW

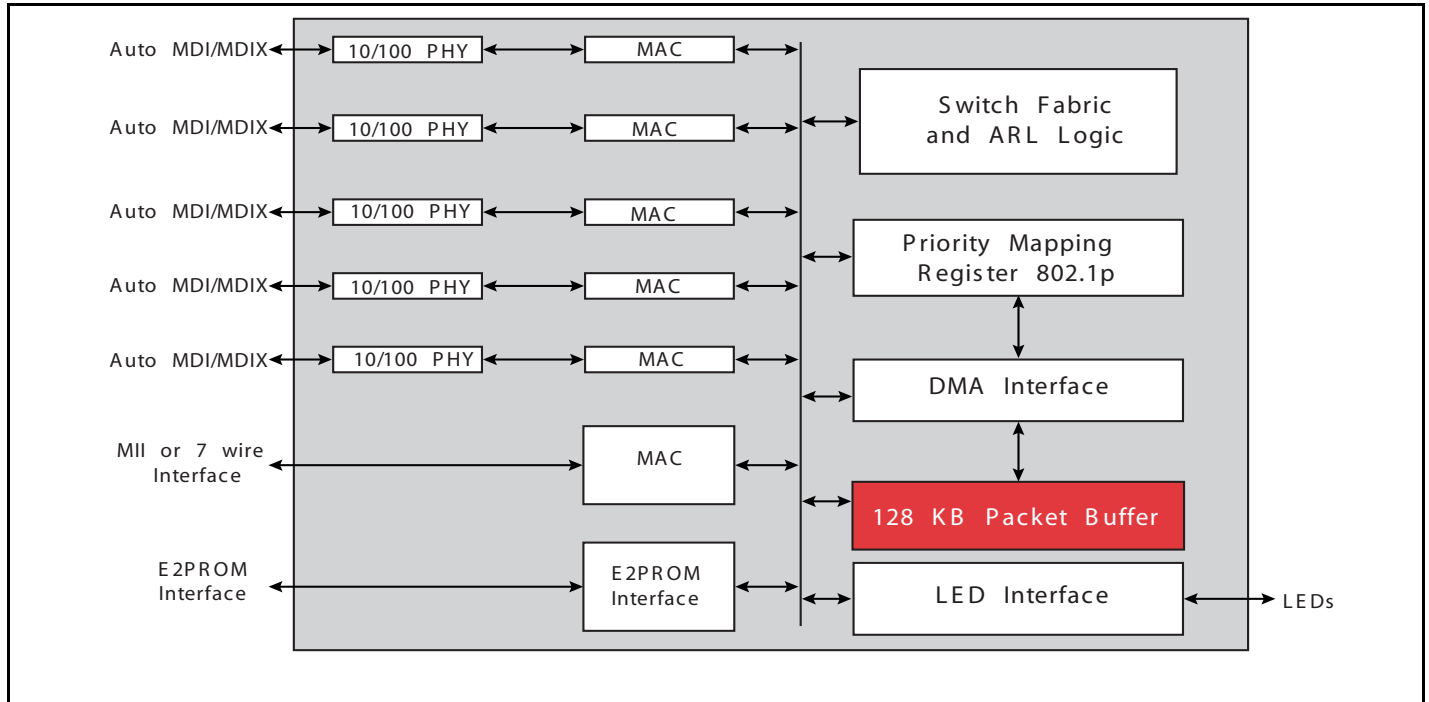

The Broadcom BCM5325 device is a highly integrated solution. It combines all of the functions of a high-speed switch system—including packet buffer, PHY transceivers, media access controllers, address management, and a nonblocking switch fabric—into a single 0.18 μ CMOS device. It complies with the IEEE 802.3, 802.3u, and 802.3x specifications, including the MAC control PAUSE frame and auto-negotiation subsections, providing compatibility with all industry-standard Ethernet and Fast Ethernet devices.

This device contains five full-duplex 10BASE-T/100BASE-TX Fast Ethernet transceivers, each of which performs all of the physical layer interface functions for 10BASE-T Ethernet on Category 3, 4, or 5 Unshielded Twisted-Pair (UTP) cable and 100BASE-TX Fast Ethernet on Category 5 UTP cable.

E2PROM interfaces provide easy programming of the 802.1p QoS queues. This allows switch traffic to be given different classes of priority or service, for example, voice traffic for IP phone applications, video traffic for multimedia applications, or data traffic for e-mail applications.

Broadcom[®], the pulse logo, and Connecting everything[®] are trademarks of Broadcom Corporation and/or its subsidiaries in the United States and certain other countries. All other trademarks mentioned are the property of their respective owners.

Connecting
everything[®]



BROADCOM CORPORATION
16215 Alton Parkway, P.O. Box 57013
Irvine, California 92619-7013

© 2004 by BROADCOM CORPORATION. All rights reserved.

5325-PB05-R 07/13/04

Phone: 949-450-8700
Fax: 949-450-8710
E-mail: info@broadcom.com
Web: www.broadcom.com