



## BCM2033 SINGLE-CHIP BLUETOOTH™ SYSTEM

### BCM2033 FEATURES

- **Complete Bluetooth™ V1.1 BQB qualified baseband and radio transceiver**
- **Radio transceiver**
  - Typical -80 dBm receiver sensitivity across passband under high interference environments
  - Fractional-N frequency generation
  - On-chip auto-calibration eliminates tuning
  - Programmable output power control meets Class 2 or Class 3 requirements
  - Supports Class 1 operation with external PA
- **Baseband**
  - Standard HCI interface
  - Seven slave multipoint and scatternet operation
  - USB, UART, PCM codec interfaces
  - Optional 8-bit slave interface
  - Full 723 kbps data rate
  - Three simultaneous SCO channels
  - Embedded microcontroller
  - On-chip power management unit
    - Park/hold/sniff
- **On-chip Power on Reset (POR)**
- **Operational in both commercial temperature range (0 C to 70 C) and industrial temperature ranges (-40 C to 105 C)**
- **Available in two packages:**
  - 8mm x 8mm, 64-pin fpBGA package
  - 9mm x 9mm, 100-pin fpBGA package

### SUMMARY OF BENEFITS

- **Single-chip implementation**
  - Complete 2.4-GHz radio transceiver and baseband
  - Minimal external component count
  - Simplify overall design/development cycle
- **High performance radio transceiver**
  - Fractional-N synthesizer provides flexibility in frequency generation eliminating the need for dedicated reference crystal
  - Robust RF performance
- **Standard digital CMOS process**
  - Most cost-effective, widely available semiconductor process
- **Embedded microcontroller and baseband to offload all processor-intensive tasks from the host computer**
- **Complete LMP and HCI provided in firmware**
- **Low power standby modes to enable very efficient power management**
- **Low overall system cost**
  - On-chip memory enables firmware download eliminating the need for external flash memory
  - Low bill of materials
- **Applications**
  - GSM, CDMA, WCDMA, GPRS, UMTS mobile phones
  - PCs, laptops, PDAs, printers
  - Peripheral devices
  - Automotive applications
  - Embedded devices

### BCM2033 Single-Chip Bluetooth™ Application Example

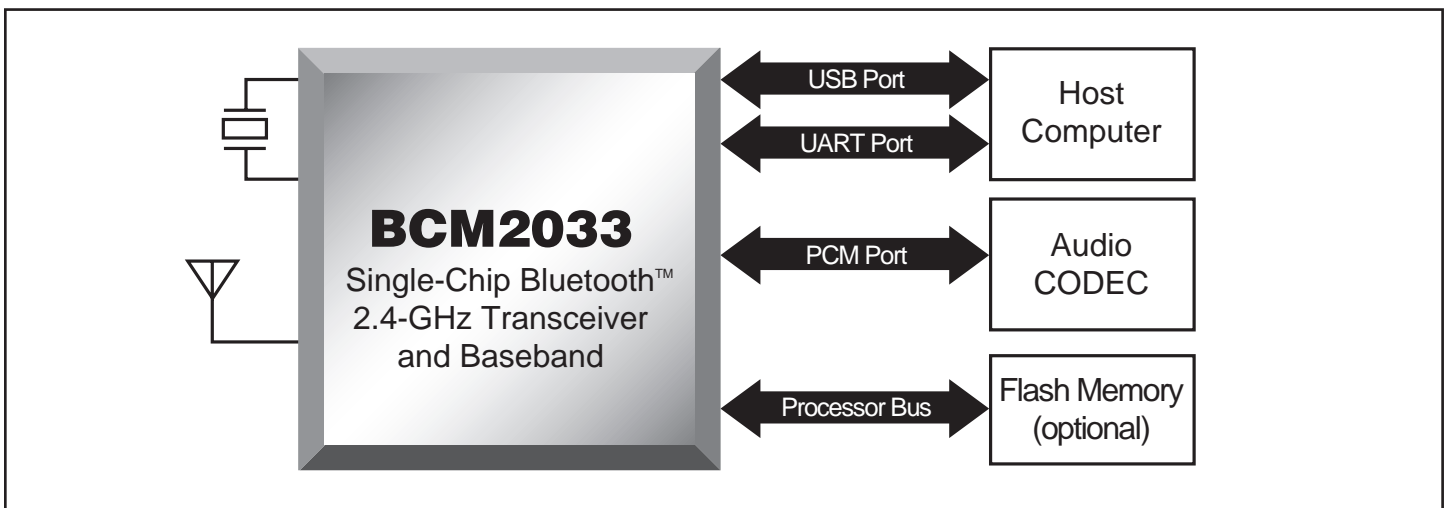

BCM2033 Functional Block Diagram

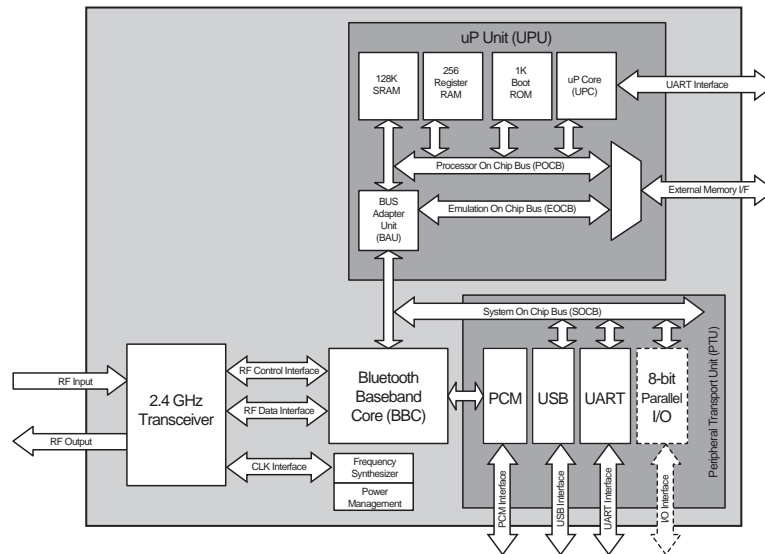

----- Available in 100-pin fpBGA package

The **BCM2033** is a complete Bluetooth™ 1.1 compliant, single-chip Bluetooth solution, integrating the 2.4 GHz fractional-N radio transceiver and baseband controller. It is an ideal solution for a wide range of wireless communication and networking applications, including mobile phones, PCs, laptops, PDAs, and other peripheral devices.

The radio section of the **BCM2033** incorporates the complete receive and transmit paths, including PLL, VCO, LNA, PA, upconverter, downconverter, modulator, demodulator, and channel select filtering.

The baseband section of the **BCM2033** controls all Bluetooth functionality from the physical layer radio to the HCI layer. This includes all bit-level processing, event scheduling, voice/data flow, and on-chip USB/UART/Audio PCM interfaces.

The single-chip Bluetooth solution is a monolithic component implemented in a standard digital CMOS process, and requires minimal external components to provide a low-cost BOM solution. The **BCM2033** is available in a 64-pin fpBGA for applications that do not need the external memory busses.

The **BCM2033** supports third-party Bluetooth upper layer protocol stacks.

The **BCM2033** supports the following interfaces:

- **UART**  
Supports RXD, TXD, RTS and CTS signals. The UART is 16C550-compatible.
- **PCM Audio Codec Serial Interface**  
The audio transcoder interface supports 13–16-bit linear PCM, 8-bit  $\mu$ -law, 8-bit A-law and CVSD audio and data formats. The serial audio interface supports standard audio CODECs.
- **USB**  
On-chip USB interface conforms to the full-speed (12 Mbps) requirements of USB specification version 1.1 with on-chip USB transceiver.
- **8051 Bus Interface**  
Accesses 64 KB to 256 KB address space for code and data with eight GPIO signals.
- **Optional 8-Bit Input/Output Slave Interface**  
Supports generic and 360-type asynchronous modes.

**Ordering Information:**

|                           |   |
|---------------------------|---|
| <b>BCM2033KFB</b> 64BGA   |   |
| <b>BCM2033MKFB</b> 100BGA | External flash, 8051 bus interface, 8-bit I/O slave interface support |

Broadcom®, the pulse logo, and Connecting everything® are trademarks of Broadcom Corporation and/or its subsidiaries in the United States and certain other countries. All other trademarks are the property of their respective owners. Bluetooth™ is a trademark owned by Telefonaktiebolaget LM Ericsson AB and licensed to participants in the Bluetooth Special Interest Group (SIG) in the United States and certain other countries. All other trademarks are the property of their respective owners.

Connecting  
everything®



**BROADCOM CORPORATION**

16215 Alton Parkway, P.O. Box 57013  
Irvine, California 92619-7013

© 2002 by BROADCOM CORPORATION. All rights reserved.

2033-PB04-R-11.01.02