

Small Signal Schottky (double) diodes

BAT54N3/BAT54AN3

BAT54CN3/BAT54SN3

Description

Planar silicon Schottky barrier diodes encapsulated in a SOT-23 small plastic SMD package. Single diodes and double diodes with different pinning are available.

Features

- Very small conduction losses
- Low forward voltage drop
- Small plastic SMD package

Applications

- Ultra high-speed switching
- Voltage clamping
- Protection circuits
- Blocking diodes

Pinning

Pin	Description			
	BAT54	BAT54A	BAT54C	BAT54S
1	A	K1	A1	A1
2	NC	K2	A2	K2
3	K	A1,A2	K1,K2	K1,A1

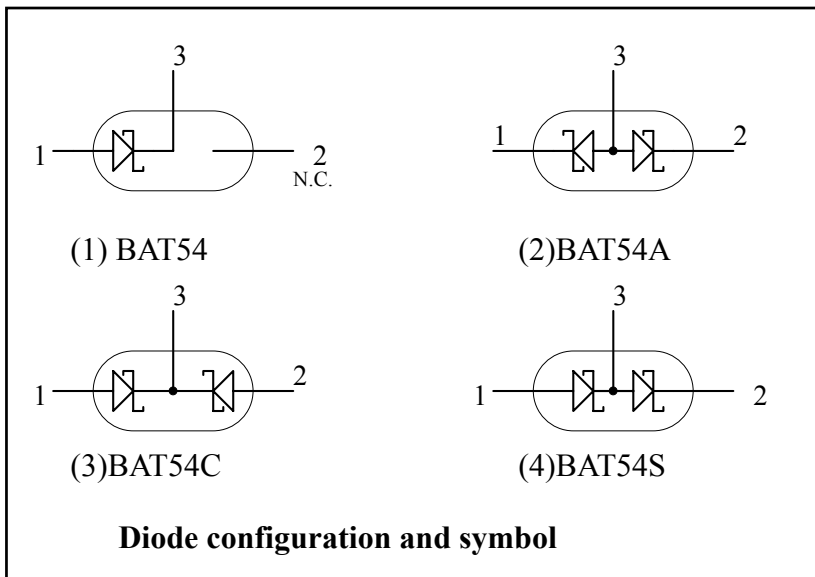

Outline

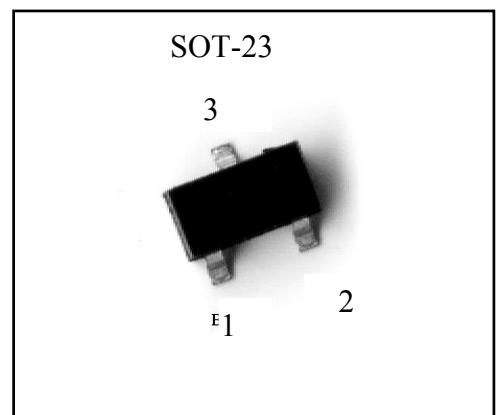

Marking:

Type	Marking Code
BAT54 N3	L4
BAT54AN3	L42
BAT54CN3	L43
BAT54SN3	L44



Absolute Maximum Ratings

- Maximum Temperatures
Storage Temperature Tstg -65~+150 °C
Junction Temperature Tj +125°C
- Maximum Power Dissipation
Total Power Dissipation (Ta=25°C) Ptot (Note) 230 mW
- Maximum Voltages and Currents (Ta=25°C)
Repetitive Peak Reverse Voltage VRRM 30 V
Continuous Forward Current IF 200 mA
Repetitive Peak Forward Current(tp≤1s,duty cycle≤0.5)..... 300mA
Non-repetitive Peak Forward Current (tp<10ms, sinusoidal) IFSM 600 mA

Note:for double diodes, Ptot is the total power dissipation of both diodes.

Characteristics (Ta=25°C)

Characteristic	Symbol	Condition	Min.	Max.	Unit
Reverse Breakdown Voltage	VBR	IR=100μA	30	-	V
Forward Voltage (Note 1)	VF(1)	IF=0.1mA	-	240	mV
	VF(2)	IF=1mA	-	320	mV
	VF(3)	IF=10mA	-	400	mV
	VF(4)	IF=30mA	-	500	mV
	VF(5)	IF=100mA	-	800	mV
Reverse Leakage Current (Note 2)	IR	VR=25V,Tj=25°C	-	2	μA
Diode Capacitance	CD	VR=1V, f=1MHz	-	10	pF
Reverse Recovery Time	trr	IF=IR=10mA RL=100Ω measured at IR=1mA	-	5	ns

Notes: 1.pulse test, tp=380μs,duty cycle<2%.
2.pulse test, tp=5ms,duty cycle<2%.



Characteristic Curves

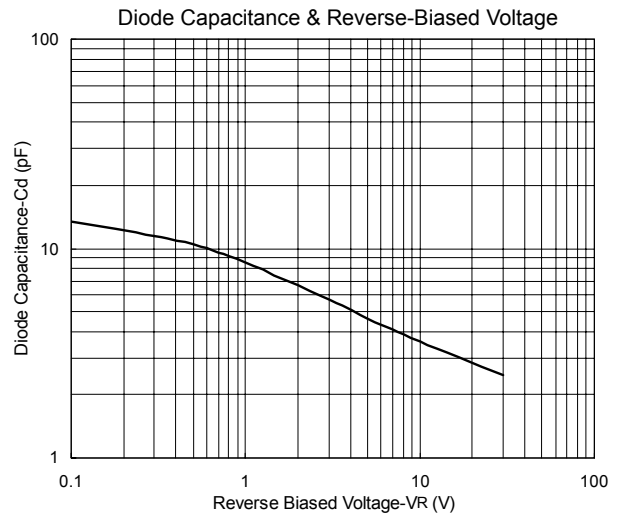
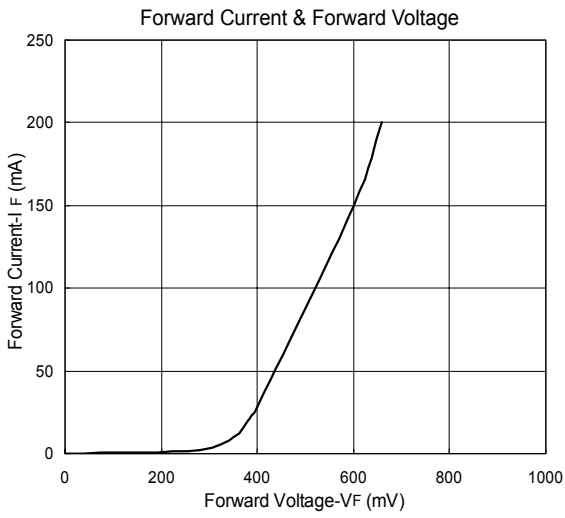

SOT-23 Dimension

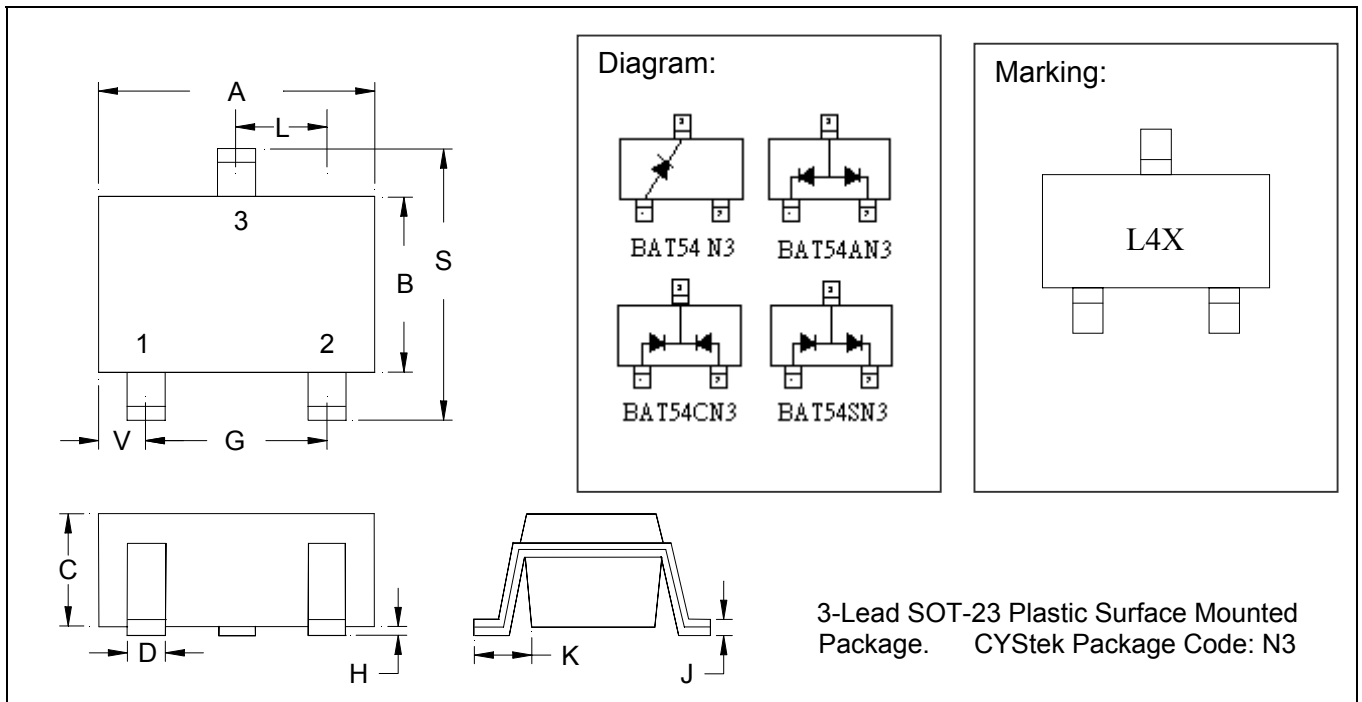

- BAT54 N3: Single Diode (Marking Code L4)
- BAT54AN3: Common Anode. (Marking Code L42)
- BAT54CN3: Common Cathode. (Marking Code L43)
- BAT54SN3: Series Connected. (Marking Code L44)

*: Typical

DIM	Inches		Millimeters		DIM	Inches		Millimeters	
	Min.	Max.	Min.	Max.		Min.	Max.	Min.	Max.
A	0.1102	0.1204	2.80	3.04	J	0.0034	0.0070	0.85	0.177
B	0.0472	0.0630	1.20	1.60	K	0.0128	0.0266	0.32	0.67
C	0.0335	0.0512	0.89	1.30	L	0.0335	0.0453	0.85	1.15
D	0.0118	0.0197	0.30	0.50	S	0.0830	0.1083	2.10	2.75
G	0.0669	0.0910	1.70	2.30	V	0.0098	0.0256	0.25	0.65
H	0.0005	0.0040	0.013	0.10					

Notes: 1.Controlling dimension: millimeters.
 2.Maximum lead thickness includes lead finish thickness, and minimum lead thickness is the minimum thickness of base material.
 3.If there is any question with packing specification or packing method, please contact your local CYStek sales office.

Material:

- Lead: 42 Alloy; solder plating
- Mold Compound: Epoxy resin family, flammability solid burning class: UL94V-0

Important Notice:

- All rights are reserved. Reproduction in whole or in part is prohibited without the prior written approval of CYStek.
- CYStek reserves the right to make changes to its products without notice.
- CYStek **semiconductor products are not warranted to be suitable for use in Life-Support Applications, or systems.**
- CYStek assumes no liability for any consequence of customer product design, infringement of patents, or application assistance.