

BAT54W/AW/CW/SW SCHOTTKY DIODE

FEATURES

Power dissipation

$$P_D: 200 \text{ mW (} T_{amb}=25 \text{)}$$

Collector current

$$I_F: 200 \text{ mA}$$

Collector-base voltage

$$V_R: 30 \text{ V}$$

Operating and storage junction temperature range

$$T_J, T_{stg}: -55 \text{ to } +150$$

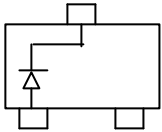
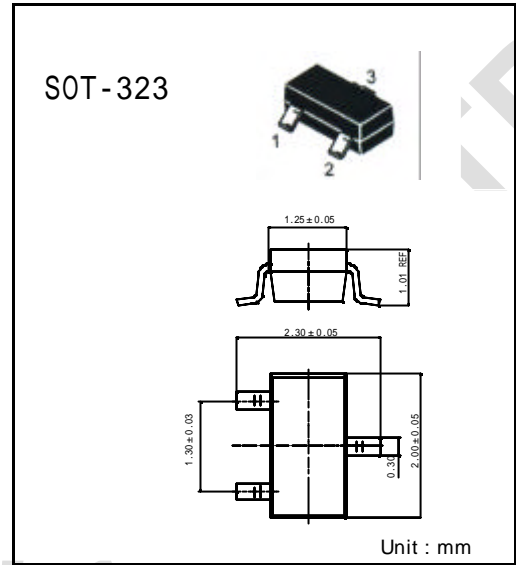

BAT54W Marking: KL5

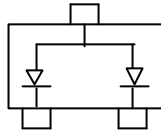

BAT54AW Marking: KL6

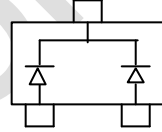

BAT54CW Marking: KL7

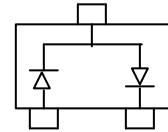

BAT54SW Marking: KL8

ELECTRICAL CHARACTERISTICS ($T_{amb}=25$ unless otherwise specified)

Parameter	Symbol	Test conditions	MIN	MAX	UNIT
Reverse breakdown voltage	$V_{(BR)R}$	$I_R=100\mu A$	30		V
Reverse voltage leakage current	I_R	$V_R=25V$		2	μA
Forward voltage	V_F	$I_F=0.1mA$ $I_F=1mA$ $I_F=10mA$ $I_F=30mA$ $I_F=100mA$		240 320 400 500 1000	mV
Diode capacitance	C_D	$V_R=1V$ $f=1MHz$		10	pF
Reveres recovery time	t_{rr}	$I_F=10mA$ through $k=10mA$ to $k=1mA$ $R_L=100$		5	nS

Typical Characteristics

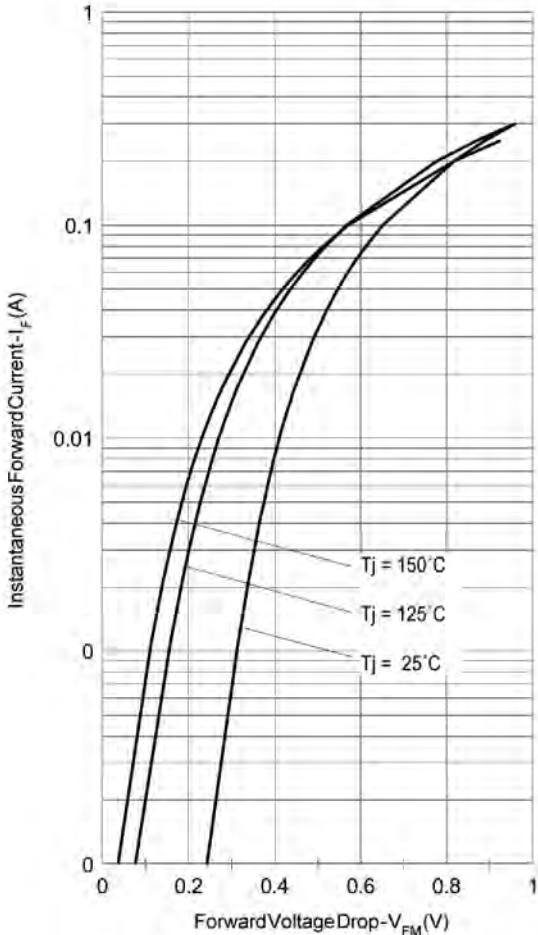

Fig. 1 - Max. Forward Voltage Drop Characteristics (Per Leg)

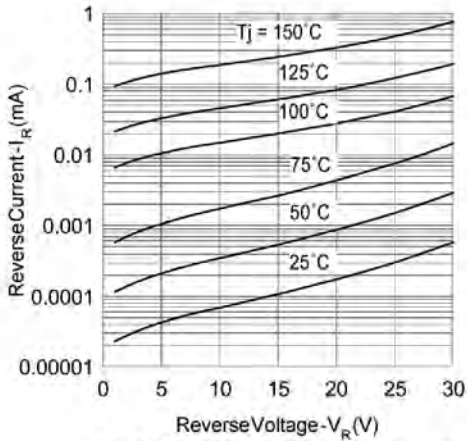

Fig. 2 - Typical Values Of Reverse Current Vs. Reverse Voltage (Per Leg)

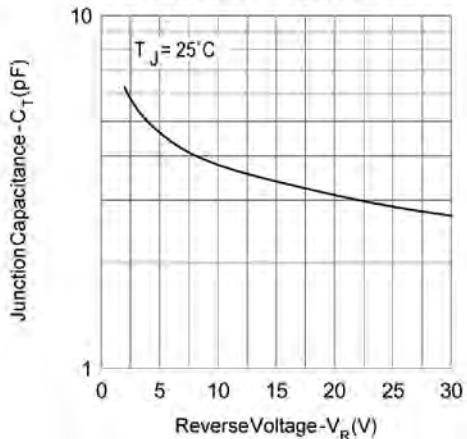

Fig. 3 - Typical Junction Capacitance Vs. Reverse Voltage (Per Leg)

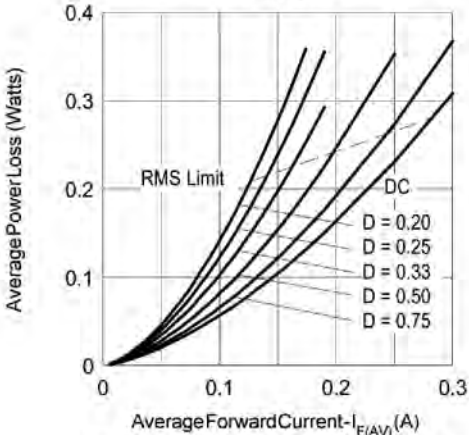

Fig. 4 - Forward Power Loss Characteristics

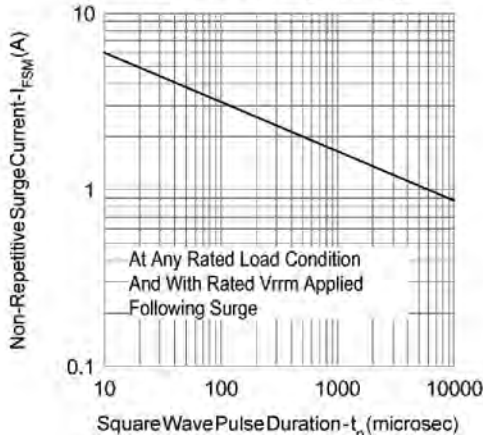
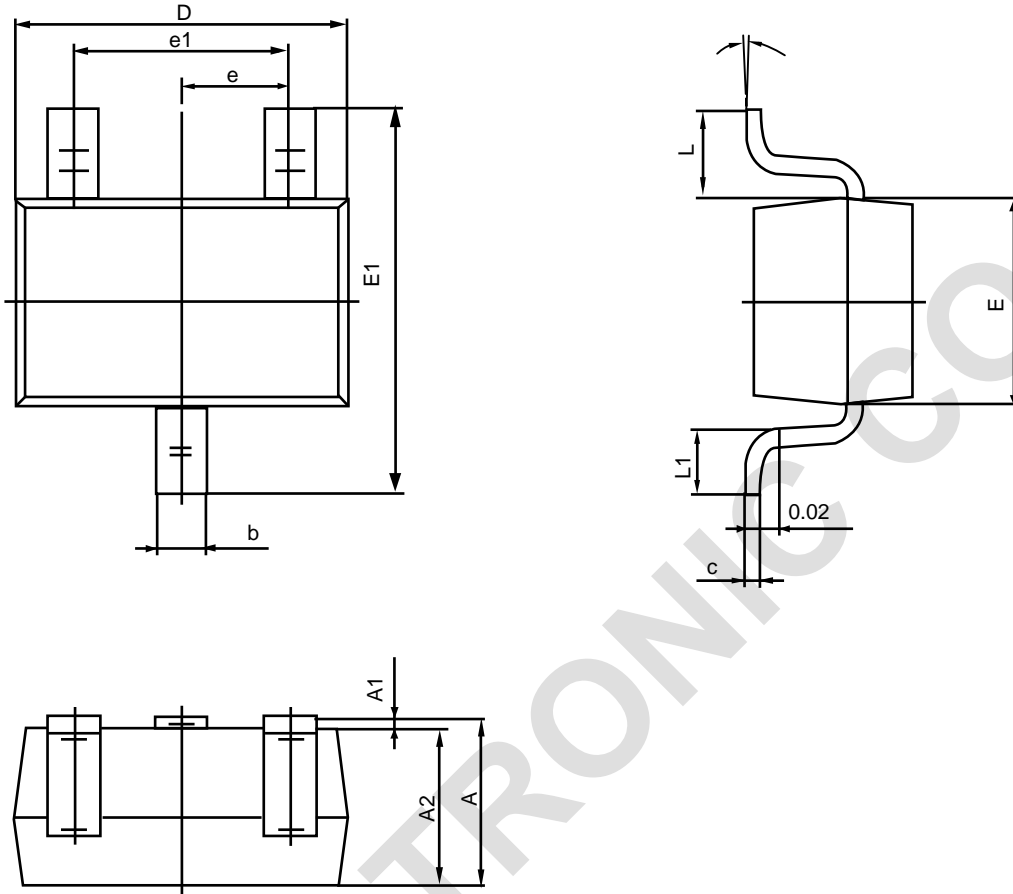

Fig. 5 - Max. Non-Repetitive Surge Current

SOT-323 PACKAGE OUTLINE DIMENSIONS



Symbol	Dimensions In Millimeters		Dimensions In Inches	
	Min	Max	Min	Max
A	0.900	1.100	0.035	0.043
A1	0.000	0.100	0.000	0.004
A2	0.900	1.000	0.035	0.039
b	0.200	0.400	0.008	0.016
c	0.080	0.150	0.003	0.006
D	2.000	2.200	0.079	0.087
E	1.150	1.350	0.045	0.053
E1	2.150	2.450	0.085	0.096
e	0.650TYP		0.026TYP	
e1	1.200	1.400	0.047	0.055
L	0.525REF		0.021REF	
L1	0.260	0.460	0.010	0.018
0	0°	8°	0°	8°