



SOT-23 Plastic-Encapsulated Diodes

BAL99LT1 SWITCHING DIODE

FEATURES

Power dissipation

$$P_D: 225 \text{ mW (Tamb=25°C)}$$

Forward Current

$$I_F: 100 \text{ mA}$$

Reverse Voltage

$$V_R: 70 \text{ V}$$

Operating and storage junction temperature range

$$T_J, T_{stg}: -55°C \text{ to } +150°C$$

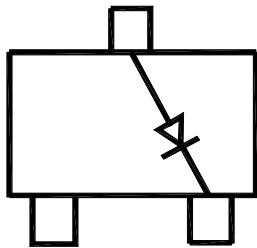
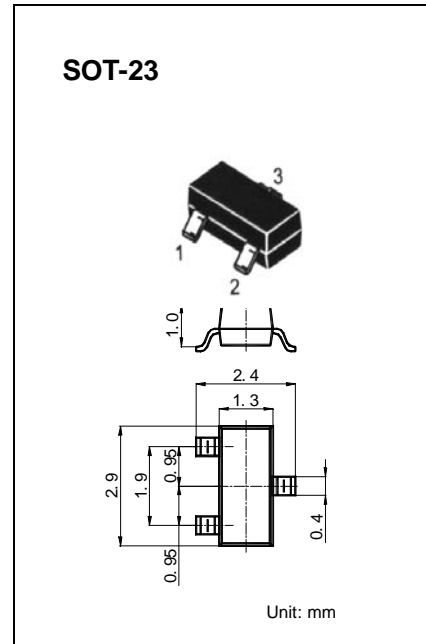

Marking JF

ELECTRICAL CHARACTERISTICS (Tamb=25°C unless otherwise specified)

Parameter	Symbol	Test conditions	MIN	MAX	UNIT
Reverse breakdown voltage	$V_{(BR)}$	$I_R = 100\mu A$	70		V
Reverse voltage leakage current	I_R	$V_R = 70V$		2.5	μA
Forward voltage	V_F	$I_F = 1mA$ $I_F = 10mA$ $I_F = 50mA$ $I_F = 150mA$		715 855 1000 1250	mV
Diode capacitance	C_D	$V_R = 0V, f = 1MHz$		1.5	pF
Reverse recovery time	t_{rr}			6	nS