

Features

- High-performance, Low-power 32-bit Atmel® AVR® Microcontroller
 - Compact Single-cycle RISC Instruction Set Including DSP Instructions
 - Read-modify-write Instructions and Atomic Bit Manipulation
 - Performance
 - Up to 64DMIPS Running at 50MHz from Flash (1 Flash Wait State)
 - Up to 36DMIPS Running at 25MHz from Flash (0 Flash Wait State)
 - Memory Protection Unit (MPU)
 - Secure Access Unit (SAU) providing User-defined Peripheral Protection
- picoPower® Technology for Ultra-low Power Consumption
- Multi-hierarchy Bus System
 - High-performance Data Transfers on Separate Buses for Increased Performance
 - 12 Peripheral DMA Channels Improve Speed for Peripheral Communication
- Internal High-speed Flash
 - 256Kbytes and 128Kbytes Versions
 - Single-cycle Access up to 25MHz
 - FlashVault Technology Allows Pre-programmed Secure Library Support for End User Applications
 - Prefetch Buffer Optimizing Instruction Execution at Maximum Speed
 - 100,000 Write Cycles, 15-year Data Retention Capability
 - Flash Security Locks and User-defined Configuration Area
- Internal High-speed SRAM, Single-cycle Access at Full Speed
 - 32Kbytes
- Interrupt Controller (INTC)
 - Autovectored Low-latency Interrupt Service with Programmable Priority
- External Interrupt Controller (EIC)
- Peripheral Event System for Direct Peripheral to Peripheral Communication
- System Functions
 - Power and Clock Manager
 - SleepWalking Power Saving Control
 - Internal System RC Oscillator (RCSYS)
 - 32 KHz Oscillator
 - Multipurpose Oscillator, Phase Locked Loop (PLL), and Digital Frequency Locked Loop (DFLL)
- Windowed Watchdog Timer (WDT)
- Asynchronous Timer (AST) with Real-time Clock Capability
 - Counter or Calendar Mode Supported
- Frequency Meter (FREQM) for Accurate Measuring of Clock Frequency
- Six 16-bit Timer/Counter (TC) Channels
 - External Clock Inputs, PWM, Capture, and Various Counting Capabilities
- PWM Channels on All I/O Pins (PWMA)
 - 8-bit PWM with a Source Clock up to 150MHz
- Four Universal Synchronous/Asynchronous Receiver/Transmitters (USART)
 - Independent Baudrate Generator, Support for SPI
 - Support for Hardware Handshaking
- One Master/Slave Serial Peripheral Interface (SPI) with Chip Select Signals
 - Up to 15 SPI Slaves can be Addressed



32-bit Atmel AVR Microcontroller

AT32UC3L0256
AT32UC3L0128

Summary



- **Two Master and Two Slave Two-wire Interfaces (TWI), 400kbit/s I²C-compatible**
- **One 8-channel Analog-to-digital Converter (ADC) with up to 12 Bits Resolution**
 - **Internal Temperature Sensor**
- **Eight Analog Comparators (AC) with Optional Window Detection**
- **Capacitive Touch (CAT) Module**
 - **Hardware-assisted Atmel® AVR® QTouch® and Atmel® AVR® QMatrix Touch Acquisition**
 - **Supports QTouch and QMatrix Capture from Capacitive Touch Sensors**
- **QTouch Library Support**
 - **Capacitive Touch Buttons, Sliders, and Wheels**
 - **QTouch and QMatrix Acquisition**
- **On-chip Non-intrusive Debug System**
 - **Nexus Class 2+, Runtime Control, Non-intrusive Data and Program Trace**
 - **aWire Single-pin Programming Trace and Debug Interface Muxed with Reset Pin**
 - **NanoTrace Provides Trace Capabilities through JTAG or aWire Interface**
- **48-pin TQFP/QFN/TLLGA (36 GPIO Pins)**
- **Five High-drive I/O Pins**
- **Single 1.62-3.6 V Power Supply**

1. Description

The Atmel® AVR® AT32UC3L0128/256 is a complete system-on-chip microcontroller based on the AVR32 UC RISC processor running at frequencies up to 50MHz. AVR32 UC is a high-performance 32-bit RISC microprocessor core, designed for cost-sensitive embedded applications, with particular emphasis on low power consumption, high code density, and high performance.

The processor implements a Memory Protection Unit (MPU) and a fast and flexible interrupt controller for supporting modern and real-time operating systems. The Secure Access Unit (SAU) is used together with the MPU to provide the required security and integrity.

Higher computation capability is achieved using a rich set of DSP instructions.

The AT32UC3L0128/256 embeds state-of-the-art picoPower technology for ultra-low power consumption. Combined power control techniques are used to bring active current consumption down to 174µA/MHz, and leakage down to 220nA while still retaining a bank of backup registers. The device allows a wide range of trade-offs between functionality and power consumption, giving the user the ability to reach the lowest possible power consumption with the feature set required for the application.

The Peripheral Direct Memory Access (DMA) controller enables data transfers between peripherals and memories without processor involvement. The Peripheral DMA controller drastically reduces processing overhead when transferring continuous and large data streams.

The AT32UC3L0128/256 incorporates on-chip Flash and SRAM memories for secure and fast access. The FlashVault technology allows secure libraries to be programmed into the device. The secure libraries can be executed while the CPU is in Secure State, but not read by non-secure software in the device. The device can thus be shipped to end customers, who will be able to program their own code into the device to access the secure libraries, but without risk of compromising the proprietary secure code.

The External Interrupt Controller (EIC) allows pins to be configured as external interrupts. Each external interrupt has its own interrupt request and can be individually masked.

The Peripheral Event System allows peripherals to receive, react to, and send peripheral events without CPU intervention. Asynchronous interrupts allow advanced peripheral operation in low power sleep modes.

The Power Manager (PM) improves design flexibility and security. The Power Manager supports SleepWalking functionality, by which a module can be selectively activated based on peripheral events, even in sleep modes where the module clock is stopped. Power monitoring is supported by on-chip Power-on Reset (POR), Brown-out Detector (BOD), and Supply Monitor (SM). The device features several oscillators, such as Phase Locked Loop (PLL), Digital Frequency Locked Loop (DFLL), Oscillator 0 (OSC0), and system RC oscillator (RCSYS). Either of these oscillators can be used as source for the system clock. The DFLL is a programmable internal oscillator from 20 to 150MHz. It can be tuned to a high accuracy if an accurate reference clock is running, e.g. the 32KHz crystal oscillator.

The Watchdog Timer (WDT) will reset the device unless it is periodically serviced by the software. This allows the device to recover from a condition that has caused the system to be unstable.

The Asynchronous Timer (AST) combined with the 32KHz crystal oscillator supports powerful real-time clock capabilities, with a maximum timeout of up to 136 years. The AST can operate in counter mode or calendar mode.

The Frequency Meter (FREQM) allows accurate measuring of a clock frequency by comparing it to a known reference clock.

The device includes six identical 16-bit Timer/Counter (TC) channels. Each channel can be independently programmed to perform frequency measurement, event counting, interval measurement, pulse generation, delay timing, and pulse width modulation.

The Pulse Width Modulation controller (PWMA) provides 8-bit PWM channels which can be synchronized and controlled from a common timer. One PWM channel is available for each I/O pin on the device, enabling applications that require multiple PWM outputs, such as LCD backlight control. The PWM channels can operate independently, with duty cycles set individually, or in interlinked mode, with multiple channels changed at the same time.

The AT32UC3L0128/256 also features many communication interfaces, like USART, SPI, and TWI, for communication intensive applications. The USART supports different communication modes, like SPI Mode and LIN Mode.

A general purpose 8-channel ADC is provided, as well as eight analog comparators (AC). The ADC can operate in 10-bit mode at full speed or in enhanced mode at reduced speed, offering up to 12-bit resolution. The ADC also provides an internal temperature sensor input channel. The analog comparators can be paired to detect when the sensing voltage is within or outside the defined reference window.

The Capacitive Touch (CAT) module senses touch on external capacitive touch sensors, using the QTouch technology. Capacitive touch sensors use no external mechanical components, unlike normal push buttons, and therefore demand less maintenance in the user application. The CAT module allows up to 17 touch sensors, or up to 16 by 8 matrix sensors to be interfaced. All touch sensors can be configured to operate autonomously without software interaction, allowing wakeup from sleep modes when activated.

Atmel offers the QTouch library for embedding capacitive touch buttons, sliders, and wheels functionality into AVR microcontrollers. The patented charge-transfer signal acquisition offers robust sensing and includes fully debounced reporting of touch keys as well as Adjacent Key Suppression® (AKS®) technology for unambiguous detection of key events. The easy-to-use QTouch Suite toolchain allows you to explore, develop, and debug your own touch applications.

The AT32UC3L0128/256 integrates a class 2+ Nexus 2.0 On-chip Debug (OCD) System, with non-intrusive real-time trace and full-speed read/write memory access, in addition to basic run-time control. The NanoTrace interface enables trace feature for aWire- or JTAG-based debuggers. The single-pin aWire interface allows all features available through the JTAG interface to be accessed through the RESET pin, allowing the JTAG pins to be used for GPIO or peripherals.



2. Overview

2.1 Block Diagram

Figure 2-1. Block Diagram

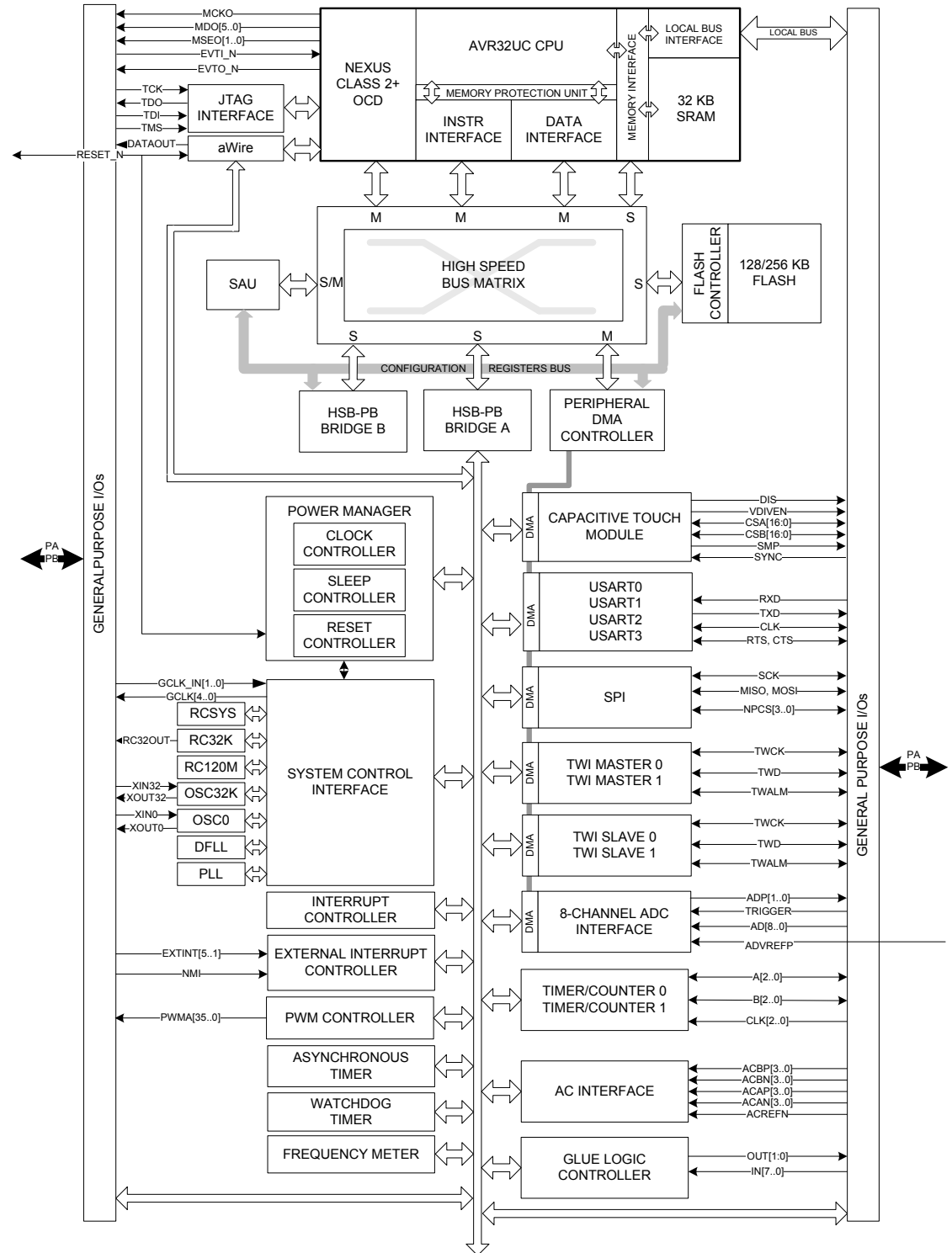

2.2 Configuration Summary

Table 2-1. Configuration Summary

Feature	AT32UC3L0256	AT32UC3L0128
Flash	256KB	128KB
SRAM	32KB	
GPIO	36	
High-drive pins	5	
External Interrupts	6	
TWI	2	
USART	4	
Peripheral DMA Channels	12	
Peripheral Event System	1	
SPI	1	
Asynchronous Timers	1	
Timer/Counter Channels	6	
PWM channels	36	
Frequency Meter	1	
Watchdog Timer	1	
Power Manager	1	
Secure Access Unit	1	
Glue Logic Controller	1	
Oscillators	Digital Frequency Locked Loop 20-150 MHz (DFLL) Phase Locked Loop 40-240 MHz (PLL) Crystal Oscillator 0.45-16 MHz (OSC0) Crystal Oscillator 32 KHz (OSC32K) RC Oscillator 120MHz (RC120M) RC Oscillator 115 kHz (RCSYS) RC Oscillator 32 kHz (RC32K)	
ADC	8-channel 12-bit	
Temperature Sensor	1	
Analog Comparators	8	
Capacitive Touch Module	1	
JTAG	1	
aWire	1	
Max Frequency	50 MHz	
Packages	TQFP48/QFN48/TLLGA48	

3. Package and Pinout

3.1 Package

The device pins are multiplexed with peripheral functions as described in [Section 3.2.1](#).

Figure 3-1. TQFP48/QFN48 Pinout

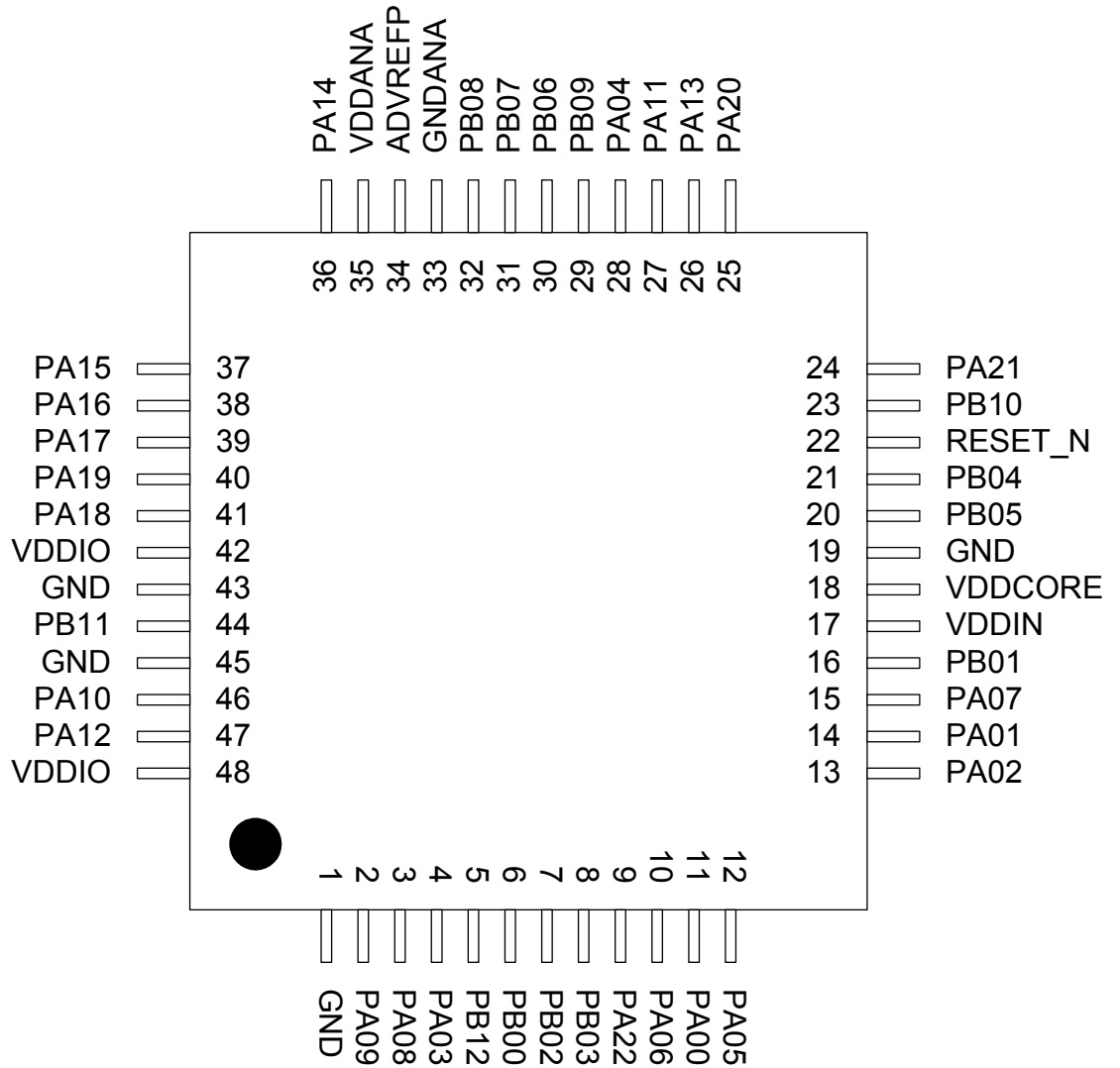
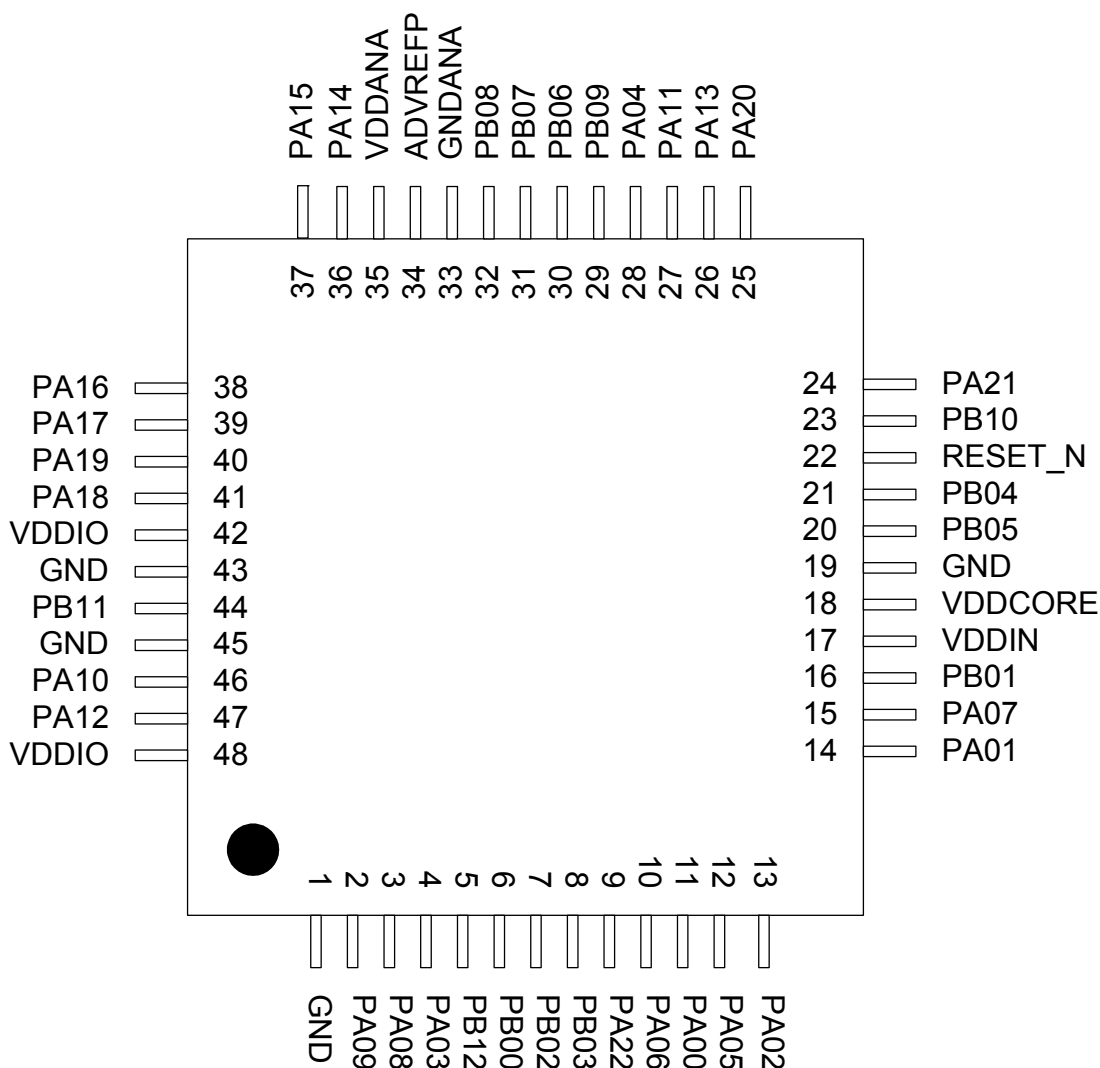

Figure 3-2. TLLGA48 Pinout



3.2 Peripheral Multiplexing on I/O Lines

3.2.1 Multiplexed Signals

Each GPIO line can be assigned to one of the peripheral functions. The following table describes the peripheral signals multiplexed to the GPIO lines.

Table 3-1. GPIO Controller Function Multiplexing

48-pin	PIN	GPIO	Supply	Pin Type	GPIO Function							
					A	B	C	D	E	F	G	H
11	PA00	0	VDDIO	Normal I/O	USART0 TXD	USART1 RTS	SPI NPCS[2]		PWMA PWMA[0]		SCIF GCLK[0]	CAT CSA[2]
14	PA01	1	VDDIO	Normal I/O	USART0 RXD	USART1 CTS	SPI NPCS[3]	USART1 CLK	PWMA PWMA[1]	ACIFB ACAP[0]	TWIM0 TWALM	CAT CSA[1]

Table 3-1. GPIO Controller Function Multiplexing

13	PA02	2	VDDIO	High-drive I/O	USART0 RTS	ADCIFB TRIGGER	USART2 TXD	TC0 A0	PWMA PWMA[2]	ACIFB ACBP[0]	USART0 CLK	CAT CSA[3]
4	PA03	3	VDDIO	Normal I/O	USART0 CTS	SPI NPCS[1]	USART2 TXD	TC0 B0	PWMA PWMA[3]	ACIFB ACBN[3]	USART0 CLK	CAT CSB[3]
28	PA04	4	VDDIO	Normal I/O	SPI MISO	TWIMS0 TWCK	USART1 RXD	TC0 B1	PWMA PWMA[4]	ACIFB ACBP[1]		CAT CSA[7]
12	PA05	5	VDDIO	Normal I/O (TWI)	SPI MOSI	TWIMS1 TWCK	USART1 TXD	TC0 A1	PWMA PWMA[5]	ACIFB ACBN[0]	TWIMS0 TWD	CAT CSB[7]
10	PA06	6	VDDIO	High-drive I/O, 5V tolerant	SPI SCK	USART2 TXD	USART1 CLK	TC0 B0	PWMA PWMA[6]	EIC EXTINT[2]	SCIF GCLK[1]	CAT CSB[1]
15	PA07	7	VDDIO	Normal I/O (TWI)	SPI NPCS[0]	USART2 RXD	TWIMS1 TWALM	TWIMS0 TWCK	PWMA PWMA[7]	ACIFB ACAN[0]	EIC NMI (EXTINT[0])	CAT CSB[2]
3	PA08	8	VDDIO	High-drive I/O	USART1 TXD	SPI NPCS[2]	TC0 A2	ADCIFB ADP[0]	PWMA PWMA[8]			CAT CSA[4]
2	PA09	9	VDDIO	High-drive I/O	USART1 RXD	SPI NPCS[3]	TC0 B2	ADCIFB ADP[1]	PWMA PWMA[9]	SCIF GCLK[2]	EIC EXTINT[1]	CAT CSB[4]
46	PA10	10	VDDIO	Normal I/O	TWIMS0 TWD		TC0 A0		PWMA PWMA[10]	ACIFB ACAP[1]	SCIF GCLK[2]	CAT CSA[5]
27	PA11	11	VDDIN	Normal I/O					PWMA PWMA[11]			
47	PA12	12	VDDIO	Normal I/O		USART2 CLK	TC0 CLK1	CAT SMP	PWMA PWMA[12]	ACIFB ACAN[1]	SCIF GCLK[3]	CAT CSB[5]
26	PA13	13	VDDIN	Normal I/O	GLOC OUT[0]	GLOC IN[7]	TC0 A0	SCIF GCLK[2]	PWMA PWMA[13]	CAT SMP	EIC EXTINT[2]	CAT CSA[0]
36	PA14	14	VDDIO	Normal I/O	ADCIFB AD[0]	TC0 CLK2	USART2 RTS	CAT SMP	PWMA PWMA[14]		SCIF GCLK[4]	CAT CSA[6]
37	PA15	15	VDDIO	Normal I/O	ADCIFB AD[1]	TC0 CLK1		GLOC IN[6]	PWMA PWMA[15]	CAT SYNC	EIC EXTINT[3]	CAT CSB[6]
38	PA16	16	VDDIO	Normal I/O	ADCIFB AD[2]	TC0 CLK0		GLOC IN[5]	PWMA PWMA[16]	ACIFB ACREFN	EIC EXTINT[4]	CAT CSA[8]
39	PA17	17	VDDIO	Normal I/O (TWI)		TC0 A1	USART2 CTS	TWIMS1 TWD	PWMA PWMA[17]	CAT SMP	CAT DIS	CAT CSB[8]
41	PA18	18	VDDIO	Normal I/O	ADCIFB AD[4]	TC0 B1		GLOC IN[4]	PWMA PWMA[18]	CAT SYNC	EIC EXTINT[5]	CAT CSB[0]
40	PA19	19	VDDIO	Normal I/O	ADCIFB AD[5]		TC0 A2	TWIMS1 TWALM	PWMA PWMA[19]	SCIF GCLK_IN[0]	CAT SYNC	CAT CSA[10]
25	PA20	20	VDDIN	Normal I/O	USART2 TXD		TC0 A1	GLOC IN[3]	PWMA PWMA[20]	SCIF RC32OUT		CAT CSA[12]
24	PA21	21	VDDIN	Normal I/O (TWI, 5V tolerant, SMBus)	USART2 RXD	TWIMS0 TWD	TC0 B1	ADCIFB TRIGGER	PWMA PWMA[21]	PWMA PWMAOD[21]	SCIF GCLK[0]	CAT SMP
9	PA22	22	VDDIO	Normal I/O	USART0 CTS	USART2 CLK	TC0 B2	CAT SMP	PWMA PWMA[22]	ACIFB ACBN[2]		CAT CSB[10]
6	PB00	32	VDDIO	Normal I/O	USART3 TXD	ADCIFB ADP[0]	SPI NPCS[0]	TC0 A1	PWMA PWMA[23]	ACIFB ACAP[2]	TC1 A0	CAT CSA[9]
16	PB01	33	VDDIO	High-drive I/O	USART3 RXD	ADCIFB ADP[1]	SPI SCK	TC0 B1	PWMA PWMA[24]		TC1 A1	CAT CSB[9]
7	PB02	34	VDDIO	Normal I/O	USART3 RTS	USART3 CLK	SPI MISO	TC0 A2	PWMA PWMA[25]	ACIFB ACAN[2]	SCIF GCLK[1]	CAT CSB[11]



Table 3-1. GPIO Controller Function Multiplexing

8	PB03	35	VDDIO	Normal I/O	USART3 CTS	USART3 CLK	SPI MOSI	TC0 B2	PWMA PWMA[26]	ACIFB ACBP[2]	TC1 A2	CAT CSA[11]
21	PB04	36	VDDIN	Normal I/O (TWI, 5V tolerant, SMBus)	TC1 A0	USART1 RTS	USART1 CLK	TWIMS0 TWALM	PWMA PWMA[27]	PWMA PWMAOD[27]	TWIMS1 TWCK	CAT CSA[14]
20	PB05	37	VDDIN	Normal I/O (TWI, 5V tolerant, SMBus)	TC1 B0	USART1 CTS	USART1 CLK	TWIMS0 TWCK	PWMA PWMA[28]	PWMA PWMAOD[28]	SCIF GCLK[3]	CAT CSB[14]
30	PB06	38	VDDIO	Normal I/O	TC1 A1	USART3 TXD	ADCIFB AD[6]	GLOC IN[2]	PWMA PWMA[29]	ACIFB ACAN[3]	EIC NMI (EXTINT[0])	CAT CSB[13]
31	PB07	39	VDDIO	Normal I/O	TC1 B1	USART3 RXD	ADCIFB AD[7]	GLOC IN[1]	PWMA PWMA[30]	ACIFB ACAP[3]	EIC EXTINT[1]	CAT CSA[13]
32	PB08	40	VDDIO	Normal I/O	TC1 A2	USART3 RTS	ADCIFB AD[8]	GLOC IN[0]	PWMA PWMA[31]	CAT SYNC	EIC EXTINT[2]	CAT CSB[12]
29	PB09	41	VDDIO	Normal I/O	TC1 B2	USART3 CTS	USART3 CLK		PWMA PWMA[32]	ACIFB ACBN[1]	EIC EXTINT[3]	CAT CSB[15]
23	PB10	42	VDDIN	Normal I/O	TC1 CLK0	USART1 TXD	USART3 CLK	GLOC OUT[1]	PWMA PWMA[33]	SCIF GCLK_IN[1]	EIC EXTINT[4]	CAT CSB[16]
44	PB11	43	VDDIO	Normal I/O	TC1 CLK1	USART1 RXD		ADCIFB TRIGGER	PWMA PWMA[34]	CAT VDIVEN	EIC EXTINT[5]	CAT CSA[16]
5	PB12	44	VDDIO	Normal I/O	TC1 CLK2		TWIMS1 TWALM	CAT SYNC	PWMA PWMA[35]	ACIFB ACBP[3]	SCIF GCLK[4]	CAT CSA[15]

See [Section 3.3](#) for a description of the various peripheral signals.

Refer to ["Electrical Characteristics" on page 41](#) for a description of the electrical properties of the pin types used.

3.2.2 TWI, 5V Tolerant, and SMBUS Pins

Some normal I/O pins offer TWI, 5V tolerance, and SMBUS features. These features are only available when either of the TWI functions or the PWMAOD function in the PWMA are selected for these pins.

Refer to the ["TWI Pin Characteristics\(1\)" on page 48](#) for a description of the electrical properties of the TWI, 5V tolerance, and SMBUS pins.

3.2.3 Peripheral Functions

Each GPIO line can be assigned to one of several peripheral functions. The following table describes how the various peripheral functions are selected. The last listed function has priority in case multiple functions are enabled on the same pin.

Table 3-2. Peripheral Functions

Function	Description
GPIO Controller Function multiplexing	GPIO and GPIO peripheral selection A to H
Nexus OCD AUX port connections	OCD trace system
aWire DATAOUT	aWire output in two-pin mode
JTAG port connections	JTAG debug port
Oscillators	OSC0, OSC32

3.2.4 JTAG Port Connections

If the JTAG is enabled, the JTAG will take control over a number of pins, irrespectively of the I/O Controller configuration.

Table 3-3. JTAG Pinout

48-pin	Pin name	JTAG pin
11	PA00	TCK
14	PA01	TMS
13	PA02	TDO
4	PA03	TDI

3.2.5 Nexus OCD AUX Port Connections

If the OCD trace system is enabled, the trace system will take control over a number of pins, irrespectively of the I/O Controller configuration. Two different OCD trace pin mappings are possible, depending on the configuration of the OCD AXS register. For details, see the AVR32 UC Technical Reference Manual.

Table 3-4. Nexus OCD AUX Port Connections

Pin	AXS=1	AXS=0
EVTI_N	PA05	PB08
MDO[5]	PA10	PB00
MDO[4]	PA18	PB04
MDO[3]	PA17	PB05
MDO[2]	PA16	PB03
MDO[1]	PA15	PB02
MDO[0]	PA14	PB09

Table 3-4. Nexus OCD AUX Port Connections

Pin	AXS=1	AXS=0
EVTO_N	PA04	PA04
MCKO	PA06	PB01
MSEO[1]	PA07	PB11
MSEO[0]	PA11	PB12

3.2.6 Oscillator Pinout

The oscillators are not mapped to the normal GPIO functions and their muxings are controlled by registers in the System Control Interface (SCIF). Please refer to the SCIF chapter for more information about this.

Table 3-5. Oscillator Pinout

48-pin	Pin Name	Oscillator Pin
3	PA08	XIN0
46	PA10	XIN32
26	PA13	XIN32_2
2	PA09	XOUT0
47	PA12	XOUT32
25	PA20	XOUT32_2

3.2.7 Other Functions

The functions listed in [Table 3-6](#) are not mapped to the normal GPIO functions. The aWire DATA pin will only be active after the aWire is enabled. The aWire DATAOUT pin will only be active after the aWire is enabled and the 2_PIN_MODE command has been sent. The WAKE_N pin is always enabled. Please refer to [Section 6.1.4 on page 40](#) for constraints on the WAKE_N pin.

Table 3-6. Other Functions

48-pin	Pin	Function
27	PA11	WAKE_N
22	RESET_N	aWire DATA
11	PA00	aWire DATAOUT

3.3 Signal Descriptions

The following table gives details on signal names classified by peripheral.

Table 3-7. Signal Descriptions List

Signal Name	Function	Type	Active Level	Comments
Analog Comparator Interface - ACIFB				
ACAN3 - ACAN0	Negative inputs for comparators "A"	Analog		
ACAP3 - ACAP0	Positive inputs for comparators "A"	Analog		
ACBN3 - ACBN0	Negative inputs for comparators "B"	Analog		
ACBP3 - ACBP0	Positive inputs for comparators "B"	Analog		
ACREFN	Common negative reference	Analog		
ADC Interface - ADCIFB				
AD8 - AD0	Analog Signal	Analog		
ADP1 - ADP0	Drive Pin for resistive touch screen	Output		
TRIGGER	External trigger	Input		
aWire - AW				
DATA	aWire data	I/O		
DATAOUT	aWire data output for 2-pin mode	I/O		
Capacitive Touch Module - CAT				
CSA16 - CSA0	Capacitive Sense A	I/O		
CSB16 - CSB0	Capacitive Sense B	I/O		
DIS	Discharge current control	Analog		
SMP	SMP signal	Output		
SYNC	Synchronize signal	Input		
VDIVEN	Voltage divider enable	Output		
External Interrupt Controller - EIC				
NMI (EXTINT0)	Non-Maskable Interrupt	Input		
EXTINT5 - EXTINT1	External interrupt	Input		
Glue Logic Controller - GLOC				
IN7 - IN0	Inputs to lookup tables	Input		
OUT1 - OUT0	Outputs from lookup tables	Output		
JTAG module - JTAG				
TCK	Test Clock	Input		
TDI	Test Data In	Input		
TDO	Test Data Out	Output		
TMS	Test Mode Select	Input		



Table 3-7. Signal Descriptions List

Power Manager - PM				
RESET_N	Reset	Input	Low	
Pulse Width Modulation Controller - PWMA				
PWMA35 - PWMA0	PWMA channel waveforms	Output		
PWMAOD35 - PWMAOD0	PWMA channel waveforms, open drain mode	Output		Not all channels support open drain mode
System Control Interface - SCIF				
GCLK4 - GCLK0	Generic Clock Output	Output		
GCLK_IN1 - GCLK_IN0	Generic Clock Input	Input		
RC32OUT	RC32K output at startup	Output		
XIN0	Crystal 0 Input	Analog/ Digital		
XIN32	Crystal 32 Input (primary location)	Analog/ Digital		
XIN32_2	Crystal 32 Input (secondary location)	Analog/ Digital		
XOUT0	Crystal 0 Output	Analog		
XOUT32	Crystal 32 Output (primary location)	Analog		
XOUT32_2	Crystal 32 Output (secondary location)	Analog		
Serial Peripheral Interface - SPI				
MISO	Master In Slave Out	I/O		
MOSI	Master Out Slave In	I/O		
NPCS3 - NPCS0	SPI Peripheral Chip Select	I/O	Low	
SCK	Clock	I/O		
Timer/Counter - TC0, TC1				
A0	Channel 0 Line A	I/O		
A1	Channel 1 Line A	I/O		
A2	Channel 2 Line A	I/O		
B0	Channel 0 Line B	I/O		
B1	Channel 1 Line B	I/O		
B2	Channel 2 Line B	I/O		
CLK0	Channel 0 External Clock Input	Input		
CLK1	Channel 1 External Clock Input	Input		
CLK2	Channel 2 External Clock Input	Input		
Two-wire Interface - TWIMS0, TWIMS1				
TWALM	SMBus SMBALERT	I/O	Low	
TWCK	Two-wire Serial Clock	I/O		
TWD	Two-wire Serial Data	I/O		

Table 3-7. Signal Descriptions List

Universal Synchronous Asynchronous Receiver Transmitter - USART0, USART1, USART2, USART3				
CLK	Clock	I/O		
CTS	Clear To Send	Input	Low	
RTS	Request To Send	Output	Low	
RXD	Receive Data	Input		
TXD	Transmit Data	Output		

Note: 1. ADCIFB: AD3 does not exist.

Table 3-8. Signal Description List, Continued

Signal Name	Function	Type	Active Level	Comments
Power				
VDDCORE	Core Power Supply / Voltage Regulator Output	Power Input/Output		1.62V to 1.98V
VDDIO	I/O Power Supply	Power Input		1.62V to 3.6V. VDDIO should always be equal to or lower than VDDIN.
VDDANA	Analog Power Supply	Power Input		1.62V to 1.98V
ADVREFP	Analog Reference Voltage	Power Input		1.62V to 1.98V
VDDIN	Voltage Regulator Input	Power Input		1.62V to 3.6V ⁽¹⁾
GNDANA	Analog Ground	Ground		
GND	Ground	Ground		
Auxiliary Port - AUX				
MCKO	Trace Data Output Clock	Output		
MDO5 - MDO0	Trace Data Output	Output		
MSEO1 - MSEO0	Trace Frame Control	Output		
EVTI_N	Event In	Input	Low	
EVTO_N	Event Out	Output	Low	
General Purpose I/O pin				
PA22 - PA00	Parallel I/O Controller I/O Port 0	I/O		
PB12 - PB00	Parallel I/O Controller I/O Port 1	I/O		

1. See [Section 6.1](#) on page 36

3.4 I/O Line Considerations

3.4.1 JTAG Pins

The JTAG is enabled if TCK is low while the RESET_N pin is released. The TCK, TMS, and TDI pins have pull-up resistors when JTAG is enabled. The TCK pin always has pull-up enabled during reset. The TDO pin is an output, driven at VDDIO, and has no pull-up resistor. The JTAG pins can be used as GPIO pins and multiplexed with peripherals when the JTAG is disabled. Please refer to [Section 3.2.4 on page 11](#) for the JTAG port connections.

3.4.2 PA00

Note that PA00 is multiplexed with TCK. PA00 GPIO function must only be used as output in the application.

3.4.3 RESET_N Pin

The RESET_N pin is a schmitt input and integrates a permanent pull-up resistor to VDDIN. As the product integrates a power-on reset detector, the RESET_N pin can be left unconnected in case no reset from the system needs to be applied to the product.

The RESET_N pin is also used for the aWire debug protocol. When the pin is used for debugging, it must not be driven by external circuitry.

3.4.4 TWI Pins PA21/PB04/PB05

When these pins are used for TWI, the pins are open-drain outputs with slew-rate limitation and inputs with spike filtering. When used as GPIO pins or used for other peripherals, the pins have the same characteristics as other GPIO pins. Selected pins are also SMBus compliant (refer to [Section 3.2.1 on page 8](#)). As required by the SMBus specification, these pins provide no leakage path to ground when the AT32UC3L0128/256 is powered down. This allows other devices on the SMBus to continue communicating even though the AT32UC3L0128/256 is not powered.

After reset a TWI function is selected on these pins instead of the GPIO. Please refer to the GPIO Module Configuration chapter for details.

3.4.5 TWI Pins PA05/PA07/PA17

When these pins are used for TWI, the pins are open-drain outputs with slew-rate limitation and inputs with spike filtering. When used as GPIO pins or used for other peripherals, the pins have the same characteristics as other GPIO pins.

After reset a TWI function is selected on these pins instead of the GPIO. Please refer to the GPIO Module Configuration chapter for details.

3.4.6 GPIO Pins

All the I/O lines integrate a pull-up resistor. Programming of this pull-up resistor is performed independently for each I/O line through the GPIO Controllers. After reset, I/O lines default as inputs with pull-up resistors disabled, except PA00 which has the pull-up resistor enabled. PA20 selects SCIF-RC32OUT (GPIO Function F) as default enabled after reset.

3.4.7 High-drive Pins

The five pins PA02, PA06, PA08, PA09, and PB01 have high-drive output capabilities. Refer to [Section 7. on page 41](#) for electrical characteristics.

3.4.8 RC32OUT Pin

3.4.8.1 *Clock output at startup*

After power-up, the clock generated by the 32kHz RC oscillator (RC32K) will be output on PA20, even when the device is still reset by the Power-On Reset Circuitry. This clock can be used by the system to start other devices or to clock a switching regulator to rise the power supply voltage up to an acceptable value.

The clock will be available on PA20, but will be disabled if one of the following conditions are true:

- PA20 is configured to use a GPIO function other than F (SCIF-RC32OUT)
- PA20 is configured as a General Purpose Input/Output (GPIO)
- The bit FRC32 in the Power Manager PPCR register is written to zero (refer to the Power Manager chapter)

The maximum amplitude of the clock signal will be defined by VDDIN.

Once the RC32K output on PA20 is disabled it can never be enabled again.

3.4.8.2 *XOUT32_2 function*

PA20 selects RC32OUT as default enabled after reset. This function is not automatically disabled when the user enables the XOUT32_2 function on PA20. This disturbs the oscillator and may result in the wrong frequency. To avoid this, RC32OUT must be disabled when XOUT32_2 is enabled.

3.4.9 ADC Input Pins

These pins are regular I/O pins powered from the VDDIO. However, when these pins are used for ADC inputs, the voltage applied to the pin must not exceed 1.98V. Internal circuitry ensures that the pin cannot be used as an analog input pin when the I/O drives to VDD. When the pins are not used for ADC inputs, the pins may be driven to the full I/O voltage range.

4. Processor and Architecture

Rev: 2.1.2.0

This chapter gives an overview of the AVR32UC CPU. AVR32UC is an implementation of the AVR32 architecture. A summary of the programming model, instruction set, and MPU is presented. For further details, see the *AVR32 Architecture Manual* and the *AVR32UC Technical Reference Manual*.

4.1 Features

- **32-bit load/store AVR32A RISC architecture**
 - 15 general-purpose 32-bit registers
 - 32-bit Stack Pointer, Program Counter and Link Register reside in register file
 - Fully orthogonal instruction set
 - Privileged and unprivileged modes enabling efficient and secure operating systems
 - Innovative instruction set together with variable instruction length ensuring industry leading code density
 - DSP extension with saturating arithmetic, and a wide variety of multiply instructions
- **3-stage pipeline allowing one instruction per clock cycle for most instructions**
 - Byte, halfword, word, and double word memory access
 - Multiple interrupt priority levels
- **MPU allows for operating systems with memory protection**
- **Secure State for supporting FlashVault technology**

4.2 AVR32 Architecture

AVR32 is a new, high-performance 32-bit RISC microprocessor architecture, designed for cost-sensitive embedded applications, with particular emphasis on low power consumption and high code density. In addition, the instruction set architecture has been tuned to allow a variety of microarchitectures, enabling the AVR32 to be implemented as low-, mid-, or high-performance processors. AVR32 extends the AVR family into the world of 32- and 64-bit applications.

Through a quantitative approach, a large set of industry recognized benchmarks has been compiled and analyzed to achieve the best code density in its class. In addition to lowering the memory requirements, a compact code size also contributes to the core's low power characteristics. The processor supports byte and halfword data types without penalty in code size and performance.

Memory load and store operations are provided for byte, halfword, word, and double word data with automatic sign- or zero extension of halfword and byte data. The C-compiler is closely linked to the architecture and is able to exploit code optimization features, both for size and speed.

In order to reduce code size to a minimum, some instructions have multiple addressing modes. As an example, instructions with immediates often have a compact format with a smaller immediate, and an extended format with a larger immediate. In this way, the compiler is able to use the format giving the smallest code size.

Another feature of the instruction set is that frequently used instructions, like add, have a compact format with two operands as well as an extended format with three operands. The larger format increases performance, allowing an addition and a data move in the same instruction in a

single cycle. Load and store instructions have several different formats in order to reduce code size and speed up execution.

The register file is organized as sixteen 32-bit registers and includes the Program Counter, the Link Register, and the Stack Pointer. In addition, register R12 is designed to hold return values from function calls and is used implicitly by some instructions.

4.3 The AVR32UC CPU

The AVR32UC CPU targets low- and medium-performance applications, and provides an advanced On-Chip Debug (OCD) system, no caches, and a Memory Protection Unit (MPU). Java acceleration hardware is not implemented.

AVR32UC provides three memory interfaces, one High Speed Bus master for instruction fetch, one High Speed Bus master for data access, and one High Speed Bus slave interface allowing other bus masters to access data RAMs internal to the CPU. Keeping data RAMs internal to the CPU allows fast access to the RAMs, reduces latency, and guarantees deterministic timing. Also, power consumption is reduced by not needing a full High Speed Bus access for memory accesses. A dedicated data RAM interface is provided for communicating with the internal data RAMs.

A local bus interface is provided for connecting the CPU to device-specific high-speed systems, such as floating-point units and I/O controller ports. This local bus has to be enabled by writing a one to the LOCEN bit in the CPUCR system register. The local bus is able to transfer data between the CPU and the local bus slave in a single clock cycle. The local bus has a dedicated memory range allocated to it, and data transfers are performed using regular load and store instructions. Details on which devices that are mapped into the local bus space is given in the CPU Local Bus section in the Memories chapter.

[Figure 4-1 on page 20](#) displays the contents of AVR32UC.

Figure 4-1. Overview of the AVR32UC CPU

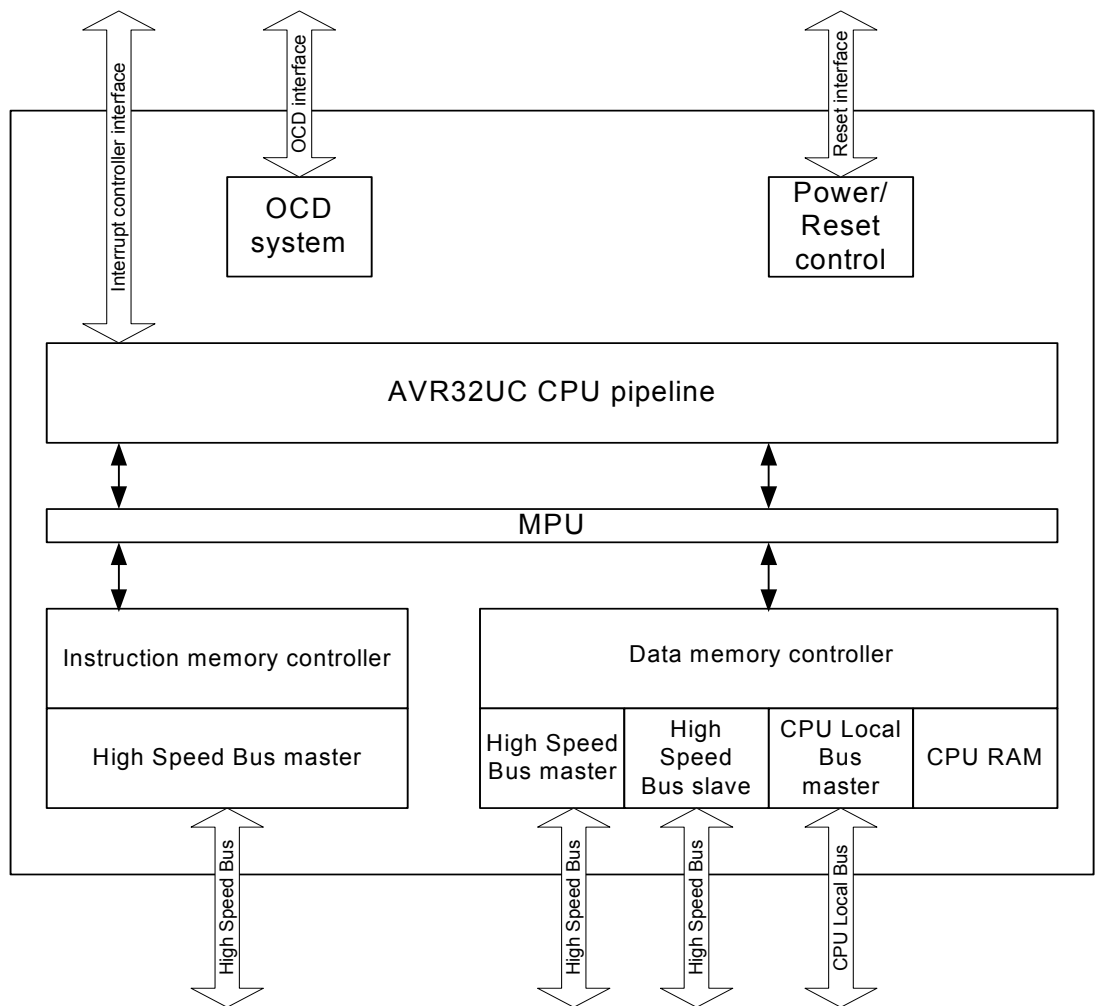

4.3.1 Pipeline Overview

AVR32UC has three pipeline stages, Instruction Fetch (IF), Instruction Decode (ID), and Instruction Execute (EX). The EX stage is split into three parallel subsections, one arithmetic/logic (ALU) section, one multiply (MUL) section, and one load/store (LS) section.

Instructions are issued and complete in order. Certain operations require several clock cycles to complete, and in this case, the instruction resides in the ID and EX stages for the required number of clock cycles. Since there is only three pipeline stages, no internal data forwarding is required, and no data dependencies can arise in the pipeline.

Figure 4-2 on page 21 shows an overview of the AVR32UC pipeline stages.

Figure 4-2. The AVR32UC Pipeline

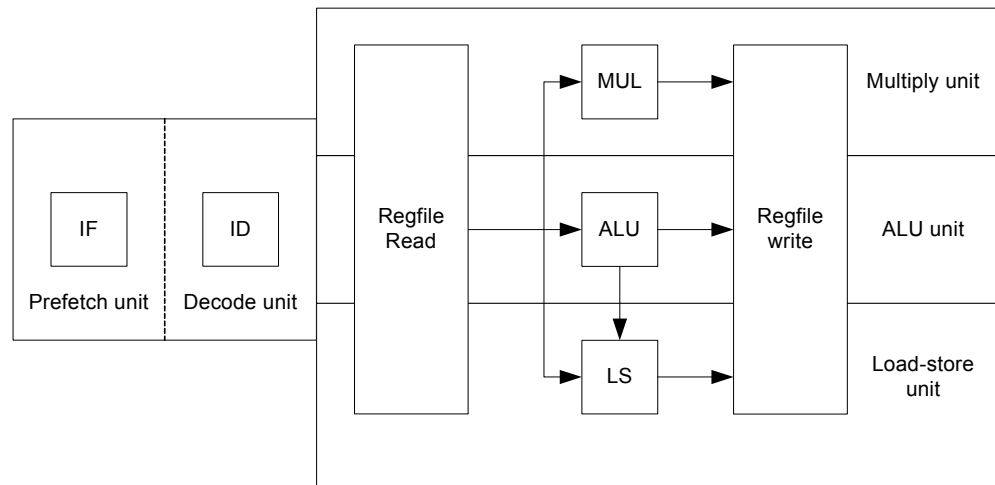

4.3.2 AVR32A Microarchitecture Compliance

AVR32UC implements an AVR32A microarchitecture. The AVR32A microarchitecture is targeted at cost-sensitive, lower-end applications like smaller microcontrollers. This microarchitecture does not provide dedicated hardware registers for shadowing of register file registers in interrupt contexts. Additionally, it does not provide hardware registers for the return address registers and return status registers. Instead, all this information is stored on the system stack. This saves chip area at the expense of slower interrupt handling.

4.3.2.1 Interrupt Handling

Upon interrupt initiation, registers R8-R12 are automatically pushed to the system stack. These registers are pushed regardless of the priority level of the pending interrupt. The return address and status register are also automatically pushed to stack. The interrupt handler can therefore use R8-R12 freely. Upon interrupt completion, the old R8-R12 registers and status register are restored, and execution continues at the return address stored popped from stack.

The stack is also used to store the status register and return address for exceptions and *scall*. Executing the *rete* or *rets* instruction at the completion of an exception or system call will pop this status register and continue execution at the popped return address.

4.3.2.2 Java Support

AVR32UC does not provide Java hardware acceleration.

4.3.2.3 Memory Protection

The MPU allows the user to check all memory accesses for privilege violations. If an access is attempted to an illegal memory address, the access is aborted and an exception is taken. The MPU in AVR32UC is specified in the AVR32UC Technical Reference manual.

4.3.2.4 Unaligned Reference Handling

AVR32UC does not support unaligned accesses, except for doubleword accesses. AVR32UC is able to perform word-aligned *st.d* and *ld.d*. Any other unaligned memory access will cause an

address exception. Doubleword-sized accesses with word-aligned pointers will automatically be performed as two word-sized accesses.

The following table shows the instructions with support for unaligned addresses. All other instructions require aligned addresses.

Table 4-1. Instructions with Unaligned Reference Support

Instruction	Supported Alignment
ld.d	Word
st.d	Word

4.3.2.5 Unimplemented Instructions

The following instructions are unimplemented in AVR32UC, and will cause an Unimplemented Instruction Exception if executed:

- All SIMD instructions
- All coprocessor instructions if no coprocessors are present
- retj, incjosp, popjc, pushjc
- tlbr, tlbs, tlbw
- cache

4.3.2.6 CPU and Architecture Revision

Three major revisions of the AVR32UC CPU currently exist. The device described in this datasheet uses CPU revision 3.

The Architecture Revision field in the CONFIG0 system register identifies which architecture revision is implemented in a specific device.

AVR32UC CPU revision 3 is fully backward-compatible with revisions 1 and 2, ie. code compiled for revision 1 or 2 is binary-compatible with revision 3 CPUs.

4.4 Programming Model

4.4.1 Register File Configuration

The AVR32UC register file is shown below.

Figure 4-3. The AVR32UC Register File

Application		Supervisor		INT0		INT1		INT2		INT3		Exception		NMI		Secure	
Bit 31	Bit 0	Bit 31	Bit 0	Bit 31	Bit 0	Bit 31	Bit 0	Bit 31	Bit 0	Bit 31	Bit 0	Bit 31	Bit 0	Bit 31	Bit 0	Bit 31	Bit 0
PC	PC	PC	PC	PC	PC	PC	PC	PC	PC	PC	PC	PC	PC	PC	PC	PC	PC
LR	LR	LR	LR	LR	LR	LR	LR	LR	LR	LR	LR	LR	LR	LR	LR	LR	LR
SP_APP	SP_SYS	SP_SYS	SP_SYS	SP_SYS	SP_SYS	SP_SYS	SP_SYS	SP_SYS	SP_SYS	SP_SYS	SP_SYS	SP_SYS	SP_SYS	SP_SYS	SP_SYS	SP_SEC	SP_SEC
R12	R12	R12	R12	R12	R12	R12	R12	R12	R12	R12	R12	R12	R12	R12	R12	R12	R12
R11	R11	R11	R11	R11	R11	R11	R11	R11	R11	R11	R11	R11	R11	R11	R11	R11	R11
R10	R10	R10	R10	R10	R10	R10	R10	R10	R10	R10	R10	R10	R10	R10	R10	R10	R10
R9	R9	R9	R9	R9	R9	R9	R9	R9	R9	R9	R9	R9	R9	R9	R9	R9	R9
R8	R8	R8	R8	R8	R8	R8	R8	R8	R8	R8	R8	R8	R8	R8	R8	R8	R8
R7	R7	R7	R7	R7	R7	R7	R7	R7	R7	R7	R7	R7	R7	R7	R7	R7	R7
R6	R6	R6	R6	R6	R6	R6	R6	R6	R6	R6	R6	R6	R6	R6	R6	R6	R6
R5	R5	R5	R5	R5	R5	R5	R5	R5	R5	R5	R5	R5	R5	R5	R5	R5	R5
R4	R4	R4	R4	R4	R4	R4	R4	R4	R4	R4	R4	R4	R4	R4	R4	R4	R4
R3	R3	R3	R3	R3	R3	R3	R3	R3	R3	R3	R3	R3	R3	R3	R3	R3	R3
R2	R2	R2	R2	R2	R2	R2	R2	R2	R2	R2	R2	R2	R2	R2	R2	R2	R2
R1	R1	R1	R1	R1	R1	R1	R1	R1	R1	R1	R1	R1	R1	R1	R1	R1	R1
R0	R0	R0	R0	R0	R0	R0	R0	R0	R0	R0	R0	R0	R0	R0	R0	R0	R0
SR	SR	SR	SR	SR	SR	SR	SR	SR	SR	SR	SR	SR	SR	SR	SR	SR	SR

SS_STATUS
SS_ADRF
SS_ADRR
SS_ADR0
SS_ADR1
SS_SP_SYS
SS_SP_APP
SS_RAR
SS_RSR

4.4.2 Status Register Configuration

The Status Register (SR) is split into two halfwords, one upper and one lower, see [Figure 4-4](#) and [Figure 4-5](#). The lower word contains the C, Z, N, V, and Q condition code flags and the R, T, and L bits, while the upper halfword contains information about the mode and state the processor executes in. Refer to the *AVR32 Architecture Manual* for details.

Figure 4-4. The Status Register High Halfword

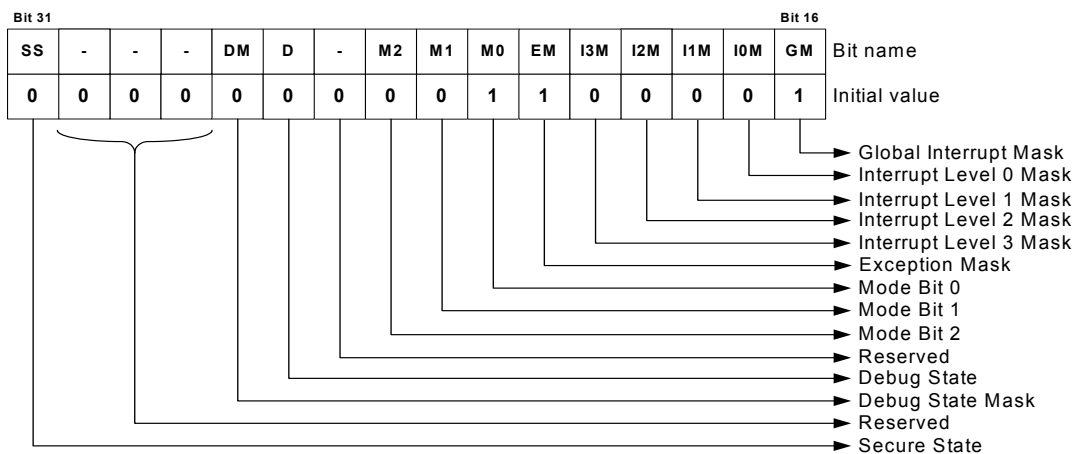
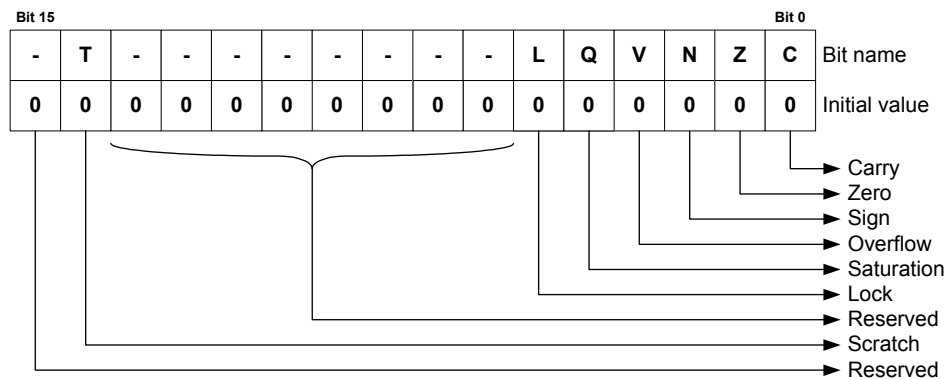

Figure 4-5. The Status Register Low Halfword



4.4.3 Processor States

4.4.3.1 Normal RISC State

The AVR32 processor supports several different execution contexts as shown in [Table 4-2](#).

Table 4-2. Overview of Execution Modes, their Priorities and Privilege Levels.

Priority	Mode	Security	Description
1	Non Maskable Interrupt	Privileged	Non Maskable high priority interrupt mode
2	Exception	Privileged	Execute exceptions
3	Interrupt 3	Privileged	General purpose interrupt mode
4	Interrupt 2	Privileged	General purpose interrupt mode
5	Interrupt 1	Privileged	General purpose interrupt mode
6	Interrupt 0	Privileged	General purpose interrupt mode
N/A	Supervisor	Privileged	Runs supervisor calls
N/A	Application	Unprivileged	Normal program execution mode

Mode changes can be made under software control, or can be caused by external interrupts or exception processing. A mode can be interrupted by a higher priority mode, but never by one with lower priority. Nested exceptions can be supported with a minimal software overhead.

When running an operating system on the AVR32, user processes will typically execute in the application mode. The programs executed in this mode are restricted from executing certain instructions. Furthermore, most system registers together with the upper halfword of the status register cannot be accessed. Protected memory areas are also not available. All other operating modes are privileged and are collectively called System Modes. They have full access to all privileged and unprivileged resources. After a reset, the processor will be in supervisor mode.

4.4.3.2 Debug State

The AVR32 can be set in a debug state, which allows implementation of software monitor routines that can read out and alter system information for use during application development. This implies that all system and application registers, including the status registers and program counters, are accessible in debug state. The privileged instructions are also available.

All interrupt levels are by default disabled when debug state is entered, but they can individually be switched on by the monitor routine by clearing the respective mask bit in the status register.

Debug state can be entered as described in the *AVR32UC Technical Reference Manual*.

Debug state is exited by the *retd* instruction.

4.4.3.3 Secure State

The AVR32 can be set in a secure state, that allows a part of the code to execute in a state with higher security levels. The rest of the code can not access resources reserved for this secure code. Secure State is used to implement FlashVault technology. Refer to the *AVR32UC Technical Reference Manual* for details.

4.4.4 System Registers

The system registers are placed outside of the virtual memory space, and are only accessible using the privileged *mfsr* and *mtsr* instructions. The table below lists the system registers specified in the AVR32 architecture, some of which are unused in AVR32UC. The programmer is responsible for maintaining correct sequencing of any instructions following a *mtsr* instruction. For detail on the system registers, refer to the *AVR32UC Technical Reference Manual*.

Table 4-3. System Registers

Reg #	Address	Name	Function
0	0	SR	Status Register
1	4	EVBA	Exception Vector Base Address
2	8	ACBA	Application Call Base Address
3	12	CPUCR	CPU Control Register
4	16	ECR	Exception Cause Register
5	20	RSR_SUP	Unused in AVR32UC
6	24	RSR_INT0	Unused in AVR32UC
7	28	RSR_INT1	Unused in AVR32UC
8	32	RSR_INT2	Unused in AVR32UC
9	36	RSR_INT3	Unused in AVR32UC
10	40	RSR_EX	Unused in AVR32UC
11	44	RSR_NMI	Unused in AVR32UC
12	48	RSR_DBG	Return Status Register for Debug mode
13	52	RAR_SUP	Unused in AVR32UC
14	56	RAR_INT0	Unused in AVR32UC
15	60	RAR_INT1	Unused in AVR32UC
16	64	RAR_INT2	Unused in AVR32UC
17	68	RAR_INT3	Unused in AVR32UC
18	72	RAR_EX	Unused in AVR32UC
19	76	RAR_NMI	Unused in AVR32UC
20	80	RAR_DBG	Return Address Register for Debug mode
21	84	JECR	Unused in AVR32UC
22	88	JOSP	Unused in AVR32UC
23	92	JAVA_LV0	Unused in AVR32UC

Table 4-3. System Registers (Continued)

Reg #	Address	Name	Function
24	96	JAVA_LV1	Unused in AVR32UC
25	100	JAVA_LV2	Unused in AVR32UC
26	104	JAVA_LV3	Unused in AVR32UC
27	108	JAVA_LV4	Unused in AVR32UC
28	112	JAVA_LV5	Unused in AVR32UC
29	116	JAVA_LV6	Unused in AVR32UC
30	120	JAVA_LV7	Unused in AVR32UC
31	124	JTBA	Unused in AVR32UC
32	128	JBCR	Unused in AVR32UC
33-63	132-252	Reserved	Reserved for future use
64	256	CONFIG0	Configuration register 0
65	260	CONFIG1	Configuration register 1
66	264	COUNT	Cycle Counter register
67	268	COMPARE	Compare register
68	272	TLBEHI	Unused in AVR32UC
69	276	TLBELO	Unused in AVR32UC
70	280	PTBR	Unused in AVR32UC
71	284	TLBEAR	Unused in AVR32UC
72	288	MMUCR	Unused in AVR32UC
73	292	TLBARLO	Unused in AVR32UC
74	296	TLBARHI	Unused in AVR32UC
75	300	PCCNT	Unused in AVR32UC
76	304	PCNT0	Unused in AVR32UC
77	308	PCNT1	Unused in AVR32UC
78	312	PCCR	Unused in AVR32UC
79	316	BEAR	Bus Error Address Register
80	320	MPUAR0	MPU Address Register region 0
81	324	MPUAR1	MPU Address Register region 1
82	328	MPUAR2	MPU Address Register region 2
83	332	MPUAR3	MPU Address Register region 3
84	336	MPUAR4	MPU Address Register region 4
85	340	MPUAR5	MPU Address Register region 5
86	344	MPUAR6	MPU Address Register region 6
87	348	MPUAR7	MPU Address Register region 7
88	352	MPUPSR0	MPU Privilege Select Register region 0
89	356	MPUPSR1	MPU Privilege Select Register region 1

Table 4-3. System Registers (Continued)

Reg #	Address	Name	Function
90	360	MPUPSR2	MPU Privilege Select Register region 2
91	364	MPUPSR3	MPU Privilege Select Register region 3
92	368	MPUPSR4	MPU Privilege Select Register region 4
93	372	MPUPSR5	MPU Privilege Select Register region 5
94	376	MPUPSR6	MPU Privilege Select Register region 6
95	380	MPUPSR7	MPU Privilege Select Register region 7
96	384	MPUCRA	Unused in this version of AVR32UC
97	388	MPUCRB	Unused in this version of AVR32UC
98	392	MPUBRA	Unused in this version of AVR32UC
99	396	MPUBRB	Unused in this version of AVR32UC
100	400	MPUAPRA	MPU Access Permission Register A
101	404	MPUAPRB	MPU Access Permission Register B
102	408	MPUCR	MPU Control Register
103	412	SS_STATUS	Secure State Status Register
104	416	SS_ADRF	Secure State Address Flash Register
105	420	SS_ADRR	Secure State Address RAM Register
106	424	SS_ADR0	Secure State Address 0 Register
107	428	SS_ADR1	Secure State Address 1 Register
108	432	SS_SP_SYS	Secure State Stack Pointer System Register
109	436	SS_SP_APP	Secure State Stack Pointer Application Register
110	440	SS_RAR	Secure State Return Address Register
111	444	SS_RSR	Secure State Return Status Register
112-191	448-764	Reserved	Reserved for future use
192-255	768-1020	IMPL	IMPLEMENTATION DEFINED

4.5 Exceptions and Interrupts

In the AVR32 architecture, events are used as a common term for exceptions and interrupts. AVR32UC incorporates a powerful event handling scheme. The different event sources, like Illegal Op-code and interrupt requests, have different priority levels, ensuring a well-defined behavior when multiple events are received simultaneously. Additionally, pending events of a higher priority class may preempt handling of ongoing events of a lower priority class.

When an event occurs, the execution of the instruction stream is halted, and execution is passed to an event handler at an address specified in [Table 4-4 on page 31](#). Most of the handlers are placed sequentially in the code space starting at the address specified by EVBA, with four bytes between each handler. This gives ample space for a jump instruction to be placed there, jumping to the event routine itself. A few critical handlers have larger spacing between them, allowing the entire event routine to be placed directly at the address specified by the EVBA-relative offset generated by hardware. All interrupt sources have autovectoring interrupt service routine (ISR) addresses. This allows the interrupt controller to directly specify the ISR address as an address

relative to EVBA. The autovector offset has 14 address bits, giving an offset of maximum 16384 bytes. The target address of the event handler is calculated as $(EVBA | event_handler_offset)$, not $(EVBA + event_handler_offset)$, so EVBA and exception code segments must be set up appropriately. The same mechanisms are used to service all different types of events, including interrupt requests, yielding a uniform event handling scheme.

An interrupt controller does the priority handling of the interrupts and provides the autovector offset to the CPU.

4.5.1 System Stack Issues

Event handling in AVR32UC uses the system stack pointed to by the system stack pointer, SP_SYS, for pushing and popping R8-R12, LR, status register, and return address. Since event code may be timing-critical, SP_SYS should point to memory addresses in the IRAM section, since the timing of accesses to this memory section is both fast and deterministic.

The user must also make sure that the system stack is large enough so that any event is able to push the required registers to stack. If the system stack is full, and an event occurs, the system will enter an UNDEFINED state.

4.5.2 Exceptions and Interrupt Requests

When an event other than *scall* or debug request is received by the core, the following actions are performed atomically:

1. The pending event will not be accepted if it is masked. The I3M, I2M, I1M, I0M, EM, and GM bits in the Status Register are used to mask different events. Not all events can be masked. A few critical events (NMI, Unrecoverable Exception, TLB Multiple Hit, and Bus Error) can not be masked. When an event is accepted, hardware automatically sets the mask bits corresponding to all sources with equal or lower priority. This inhibits acceptance of other events of the same or lower priority, except for the critical events listed above. Software may choose to clear some or all of these bits after saving the necessary state if other priority schemes are desired. It is the event source's responsibility to ensure that their events are left pending until accepted by the CPU.
2. When a request is accepted, the Status Register and Program Counter of the current context is stored to the system stack. If the event is an INT0, INT1, INT2, or INT3, registers R8-R12 and LR are also automatically stored to stack. Storing the Status Register ensures that the core is returned to the previous execution mode when the current event handling is completed. When exceptions occur, both the EM and GM bits are set, and the application may manually enable nested exceptions if desired by clearing the appropriate bit. Each exception handler has a dedicated handler address, and this address uniquely identifies the exception source.
3. The Mode bits are set to reflect the priority of the accepted event, and the correct register file bank is selected. The address of the event handler, as shown in [Table 4-4 on page 31](#), is loaded into the Program Counter.

The execution of the event handler routine then continues from the effective address calculated.

The *rete* instruction signals the end of the event. When encountered, the Return Status Register and Return Address Register are popped from the system stack and restored to the Status Register and Program Counter. If the *rete* instruction returns from INT0, INT1, INT2, or INT3, registers R8-R12 and LR are also popped from the system stack. The restored Status Register contains information allowing the core to resume operation in the previous execution mode. This concludes the event handling.

4.5.3 Supervisor Calls

The AVR32 instruction set provides a supervisor mode call instruction. The *scall* instruction is designed so that privileged routines can be called from any context. This facilitates sharing of code between different execution modes. The *scall* mechanism is designed so that a minimal execution cycle overhead is experienced when performing supervisor routine calls from time-critical event handlers.

The *scall* instruction behaves differently depending on which mode it is called from. The behaviour is detailed in the instruction set reference. In order to allow the *scall* routine to return to the correct context, a return from supervisor call instruction, *rets*, is implemented. In the AVR32UC CPU, *scall* and *rets* uses the system stack to store the return address and the status register.

4.5.4 Debug Requests

The AVR32 architecture defines a dedicated Debug mode. When a debug request is received by the core, Debug mode is entered. Entry into Debug mode can be masked by the DM bit in the status register. Upon entry into Debug mode, hardware sets the SR.D bit and jumps to the Debug Exception handler. By default, Debug mode executes in the exception context, but with dedicated Return Address Register and Return Status Register. These dedicated registers remove the need for storing this data to the system stack, thereby improving debuggability. The Mode bits in the Status Register can freely be manipulated in Debug mode, to observe registers in all contexts, while retaining full privileges.

Debug mode is exited by executing the *retd* instruction. This returns to the previous context.

4.5.5 Entry Points for Events

Several different event handler entry points exist. In AVR32UC, the reset address is 0x80000000. This places the reset address in the boot flash memory area.

TLB miss exceptions and *scall* have a dedicated space relative to EVBA where their event handler can be placed. This speeds up execution by removing the need for a jump instruction placed at the program address jumped to by the event hardware. All other exceptions have a dedicated event routine entry point located relative to EVBA. The handler routine address identifies the exception source directly.

AVR32UC uses the ITLB and DTLB protection exceptions to signal a MPU protection violation. ITLB and DTLB miss exceptions are used to signal that an access address did not map to any of the entries in the MPU. TLB multiple hit exception indicates that an access address did map to multiple TLB entries, signalling an error.

All interrupt requests have entry points located at an offset relative to EVBA. This autovector offset is specified by an interrupt controller. The programmer must make sure that none of the autovector offsets interfere with the placement of other code. The autovector offset has 14 address bits, giving an offset of maximum 16384 bytes.

Special considerations should be made when loading EVBA with a pointer. Due to security considerations, the event handlers should be located in non-writeable flash memory, or optionally in a privileged memory protection region if an MPU is present.

If several events occur on the same instruction, they are handled in a prioritized way. The priority ordering is presented in [Table 4-4 on page 31](#). If events occur on several instructions at different locations in the pipeline, the events on the oldest instruction are always handled before any events on any younger instruction, even if the younger instruction has events of higher priority

than the oldest instruction. An instruction B is younger than an instruction A if it was sent down the pipeline later than A.

The addresses and priority of simultaneous events are shown in [Table 4-4 on page 31](#). Some of the exceptions are unused in AVR32UC since it has no MMU, coprocessor interface, or floating-point unit.

Table 4-4. Priority and Handler Addresses for Events

Priority	Handler Address	Name	Event source	Stored Return Address
1	0x80000000	Reset	External input	Undefined
2	Provided by OCD system	OCD Stop CPU	OCD system	First non-completed instruction
3	EVBA+0x00	Unrecoverable exception	Internal	PC of offending instruction
4	EVBA+0x04	TLB multiple hit	MPU	PC of offending instruction
5	EVBA+0x08	Bus error data fetch	Data bus	First non-completed instruction
6	EVBA+0x0C	Bus error instruction fetch	Data bus	First non-completed instruction
7	EVBA+0x10	NMI	External input	First non-completed instruction
8	Autovectored	Interrupt 3 request	External input	First non-completed instruction
9	Autovectored	Interrupt 2 request	External input	First non-completed instruction
10	Autovectored	Interrupt 1 request	External input	First non-completed instruction
11	Autovectored	Interrupt 0 request	External input	First non-completed instruction
12	EVBA+0x14	Instruction Address	CPU	PC of offending instruction
13	EVBA+0x50	ITLB Miss	MPU	PC of offending instruction
14	EVBA+0x18	ITLB Protection	MPU	PC of offending instruction
15	EVBA+0x1C	Breakpoint	OCD system	First non-completed instruction
16	EVBA+0x20	Illegal Opcode	Instruction	PC of offending instruction
17	EVBA+0x24	Unimplemented instruction	Instruction	PC of offending instruction
18	EVBA+0x28	Privilege violation	Instruction	PC of offending instruction
19	EVBA+0x2C	Floating-point	UNUSED	
20	EVBA+0x30	Coprocessor absent	Instruction	PC of offending instruction
21	EVBA+0x100	Supervisor call	Instruction	PC(Supervisor Call) +2
22	EVBA+0x34	Data Address (Read)	CPU	PC of offending instruction
23	EVBA+0x38	Data Address (Write)	CPU	PC of offending instruction
24	EVBA+0x60	DTLB Miss (Read)	MPU	PC of offending instruction
25	EVBA+0x70	DTLB Miss (Write)	MPU	PC of offending instruction
26	EVBA+0x3C	DTLB Protection (Read)	MPU	PC of offending instruction
27	EVBA+0x40	DTLB Protection (Write)	MPU	PC of offending instruction
28	EVBA+0x44	DTLB Modified	UNUSED	

5. Memories

5.1 Embedded Memories

- Internal high-speed flash
 - 256Kbytes (AT32UC3L0256)
 - 128Kbytes (AT32UC3L0128)
 - 0 wait state access at up to 25MHz in worst case conditions
 - 1 wait state access at up to 50MHz in worst case conditions
 - Pipelined flash architecture, allowing burst reads from sequential flash locations, hiding penalty of 1 wait state access
 - Pipelined flash architecture typically reduces the cycle penalty of 1 wait state operation to only 8% compared to 0 wait state operation
 - 100 000 write cycles, 15-year data retention capability
 - Sector lock capabilities, bootloader protection, security bit
 - 32 fuses, erased during chip erase
 - User page for data to be preserved during chip erase
- Internal high-speed SRAM, single-cycle access at full speed
 - 32Kbytes

5.2 Physical Memory Map

The system bus is implemented as a bus matrix. All system bus addresses are fixed, and they are never remapped in any way, not even during boot. Note that AVR32 UC CPU uses unsegmented translation, as described in the AVR32 Architecture Manual. The 32-bit physical address space is mapped as follows:

Table 5-1. AT32UC3L0128/256 Physical Memory Map

Device	Start Address	Size	
		AT32UC3L0256	AT32UC3L0128
Embedded SRAM	0x00000000	32Kbytes	32Kbytes
Embedded Flash	0x80000000	256Kbytes	128Kbytes
SAU Channels	0x90000000	256 bytes	256 bytes
HSB-PB Bridge B	0xFFFE0000	64Kbytes	64Kbytes
HSB-PB Bridge A	0xFFFF0000	64Kbytes	64Kbytes

Table 5-2. Flash Memory Parameters

Part Number	Flash Size (<i>FLASH_PW</i>)	Number of pages (<i>FLASH_P</i>)	Page size (<i>FLASH_W</i>)
AT32UC3L0256	256Kbytes	512	512bytes
AT32UC3L0128	128Kbytes	256	512bytes

5.3 Peripheral Address Map

Table 5-3. Peripheral Address Mapping

Address		Peripheral Name
0xFFFE0000	FLASHCDW	Flash Controller - FLASHCDW
0xFFFE0400	HMATRIX	HSB Matrix - HMATRIX
0xFFFE0800	SAU	Secure Access Unit - SAU
0xFFFF0000	PDCA	Peripheral DMA Controller - PDCA
0xFFFF1000	INTC	Interrupt controller - INTC
0xFFFF1400	PM	Power Manager - PM
0xFFFF1800	SCIF	System Control Interface - SCIF
0xFFFF1C00	AST	Asynchronous Timer - AST
0xFFFF2000	WDT	Watchdog Timer - WDT
0xFFFF2400	EIC	External Interrupt Controller - EIC
0xFFFF2800	FREQM	Frequency Meter - FREQM
0xFFFF2C00	GPIO	General-Purpose Input/Output Controller - GPIO
0xFFFF3000	USART0	Universal Synchronous Asynchronous Receiver Transmitter - USART0
0xFFFF3400	USART1	Universal Synchronous Asynchronous Receiver Transmitter - USART1
0xFFFF3800	USART2	Universal Synchronous Asynchronous Receiver Transmitter - USART2
0xFFFF3C00	USART3	Universal Synchronous Asynchronous Receiver Transmitter - USART3
0xFFFF4000	SPI	Serial Peripheral Interface - SPI
0xFFFF4400	TWIM0	Two-wire Master Interface - TWIM0

Table 5-3. Peripheral Address Mapping

0xFFFF4800	TWIM1	Two-wire Master Interface - TWIM1
0xFFFF4C00	TWIS0	Two-wire Slave Interface - TWIS0
0xFFFF5000	TWIS1	Two-wire Slave Interface - TWIS1
0xFFFF5400	PWMA	Pulse Width Modulation Controller - PWMA
0xFFFF5800	TC0	Timer/Counter - TC0
0xFFFF5C00	TC1	Timer/Counter - TC1
0xFFFF6000	ADCIFB	ADC Interface - ADCIFB
0xFFFF6400	ACIFB	Analog Comparator Interface - ACIFB
0xFFFF6800	CAT	Capacitive Touch Module - CAT
0xFFFF6C00	GLOC	Glue Logic Controller - GLOC
0xFFFF7000	AW	aWire - AW

5.4 CPU Local Bus Mapping

Some of the registers in the GPIO module are mapped onto the CPU local bus, in addition to being mapped on the Peripheral Bus. These registers can therefore be reached both by accesses on the Peripheral Bus, and by accesses on the local bus.

Mapping these registers on the local bus allows cycle-deterministic toggling of GPIO pins since the CPU and GPIO are the only modules connected to this bus. Also, since the local bus runs at CPU speed, one write or read operation can be performed per clock cycle to the local bus-mapped GPIO registers.

The following GPIO registers are mapped on the local bus:

Table 5-4. Local Bus Mapped GPIO Registers

Port	Register	Mode	Local Bus Address	Access
0	Output Driver Enable Register (ODER)	WRITE	0x40000040	Write-only
		SET	0x40000044	Write-only
		CLEAR	0x40000048	Write-only
		TOGGLE	0x4000004C	Write-only
	Output Value Register (OVR)	WRITE	0x40000050	Write-only
		SET	0x40000054	Write-only
		CLEAR	0x40000058	Write-only
		TOGGLE	0x4000005C	Write-only
	Pin Value Register (PVR)	-	0x40000060	Read-only
	1	Output Driver Enable Register (ODER)	WRITE	0x40000140
SET			0x40000144	Write-only
CLEAR			0x40000148	Write-only
TOGGLE			0x4000014C	Write-only
Output Value Register (OVR)		WRITE	0x40000150	Write-only
		SET	0x40000154	Write-only
		CLEAR	0x40000158	Write-only
		TOGGLE	0x4000015C	Write-only
Pin Value Register (PVR)		-	0x40000160	Read-only

6. Supply and Startup Considerations

6.1 Supply Considerations

6.1.1 Power Supplies

The AT32UC3L0128/256 has several types of power supply pins:

- VDDIO: Powers I/O lines. Voltage is 1.8 to 3.3V nominal.
- VDDIN: Powers I/O lines and the internal regulator. Voltage is 1.8 to 3.3V nominal.
- VDDANA: Powers the ADC. Voltage is 1.8V nominal.
- VDDCORE: Powers the core, memories, and peripherals. Voltage is 1.8V nominal.

The ground pins GND are common to VDDCORE, VDDIO, and VDDIN. The ground pin for VDDANA is GNDANA.

When VDDCORE is not connected to VDDIN, the VDDIN voltage must be higher than 1.98V.

Refer to [Section 7. on page 41](#) for power consumption on the various supply pins.

For decoupling recommendations for the different power supplies, please refer to the schematic checklist.

Refer to [Section 3.2 on page 8](#) for power supply connections for I/O pins.

6.1.2 Voltage Regulator

The AT32UC3L0128/256 embeds a voltage regulator that converts from 3.3V nominal to 1.8V with a load of up to 60mA. The regulator supplies the output voltage on VDDCORE. The regulator may only be used to drive internal circuitry in the device. VDDCORE should be externally connected to the 1.8V domains. See [Section 6.1.3](#) for regulator connection figures.

Adequate output supply decoupling is mandatory for VDDCORE to reduce ripple and avoid oscillations. The best way to achieve this is to use two capacitors in parallel between VDDCORE and GND as close to the device as possible. Please refer to [Section 7.8.1 on page 55](#) for decoupling capacitors values and regulator characteristics.

Figure 6-1. Supply Decoupling

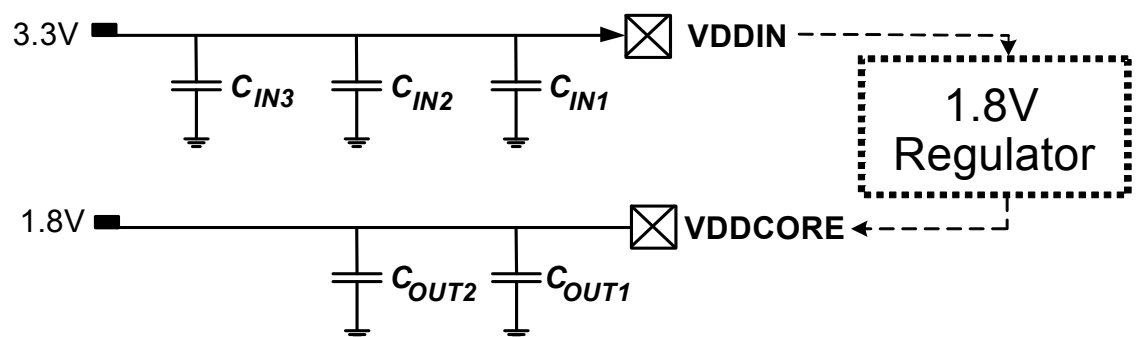

The voltage regulator can be turned off in the shutdown mode to power down the core logic and keep a small part of the system powered in order to reduce power consumption. To enter this mode the 3.3V supply mode, with 1.8V regulated I/O lines power supply configuration must be used.

6.1.3 Regulator Connection

The AT32UC3L0128/256 supports three power supply configurations:

- 3.3V single supply mode
 - Shutdown mode is not available
- 1.8V single supply mode
 - Shutdown mode is not available
- 3.3V supply mode, with 1.8V regulated I/O lines
 - Shutdown mode is available

6.1.3.1 3.3V Single Supply Mode

In 3.3V single supply mode the internal regulator is connected to the 3.3V source (VDDIN pin) and its output feeds VDDCORE. Figure 6-2 shows the power schematics to be used for 3.3V single supply mode. All I/O lines will be powered by the same power (VDDIN=VDDIO).

Figure 6-2. 3.3V Single Supply Mode

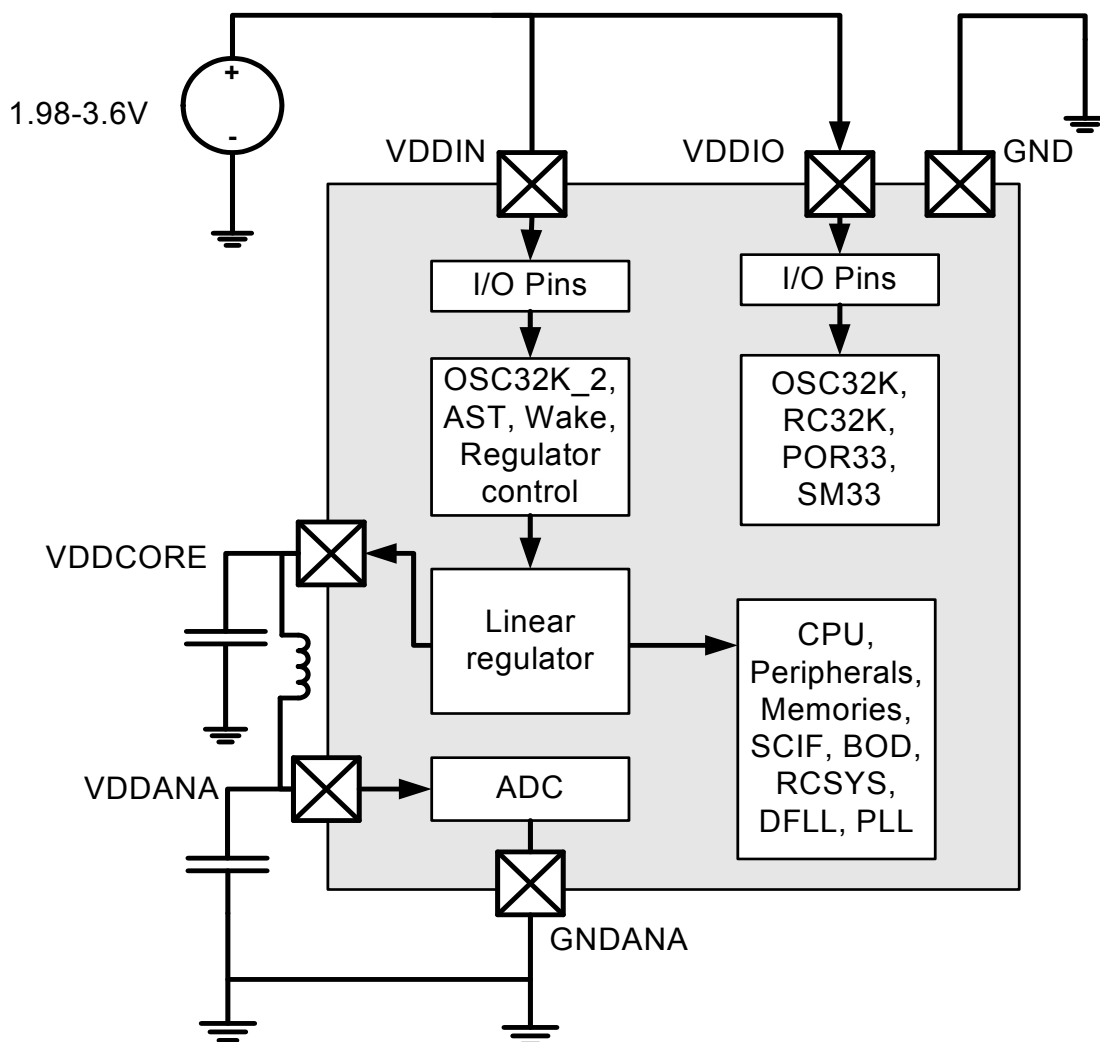

6.1.3.2 1.8V Single Supply Mode

In 1.8V single supply mode the internal regulator is not used, and VDDIO and VDDCORE are powered by a single 1.8V supply as shown in Figure 6-3. All I/O lines will be powered by the same power (VDDIN = VDDIO = VDDCORE).

Figure 6-3. 1.8V Single Supply Mode.

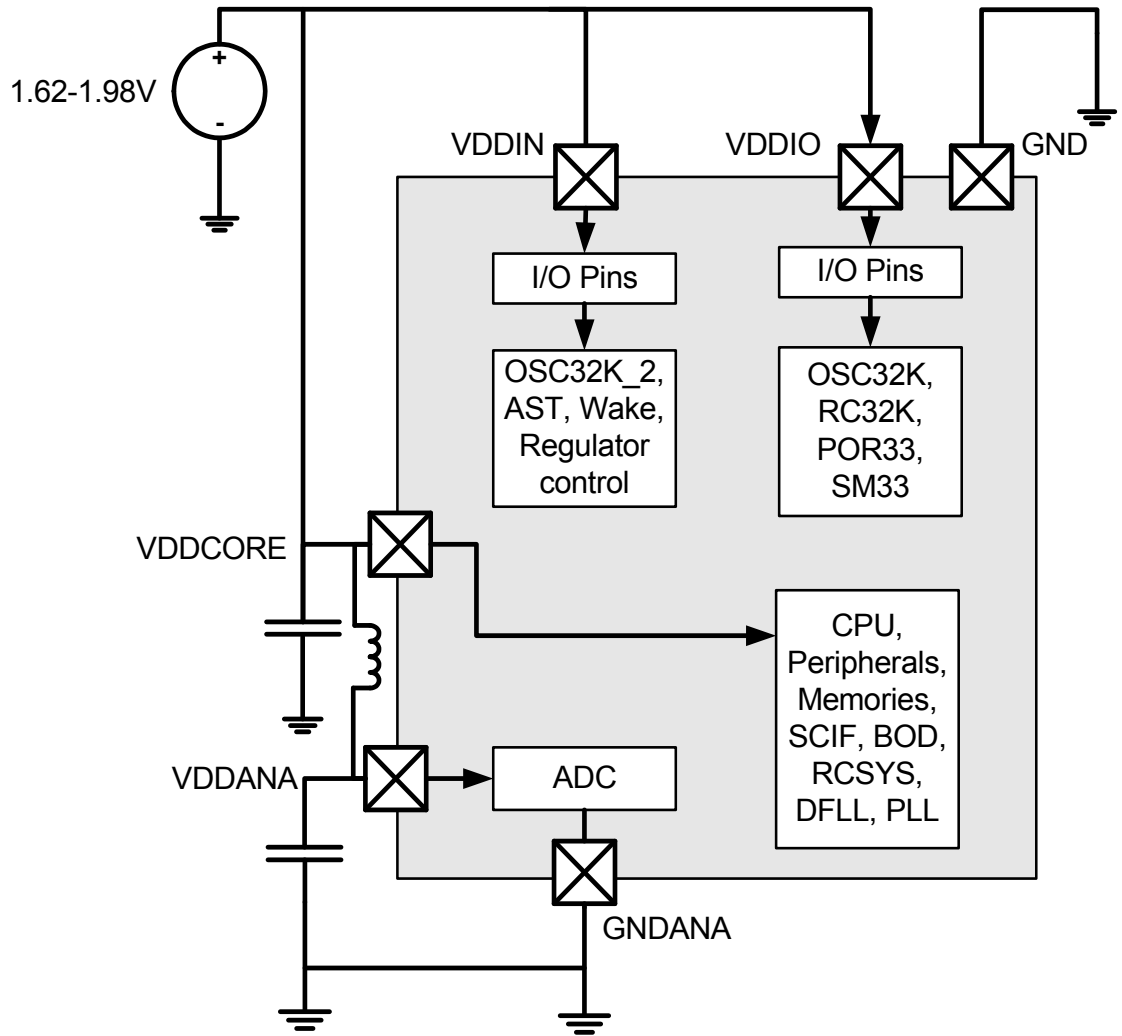

6.1.3.3 3.3V Supply Mode with 1.8V Regulated I/O Lines

In this mode, the internal regulator is connected to the 3.3V source and its output is connected to both VDDCORE and VDDIO as shown in Figure 6-4. This configuration is required in order to use Shutdown mode.

Figure 6-4. 3.3V Supply Mode with 1.8V Regulated I/O Lines

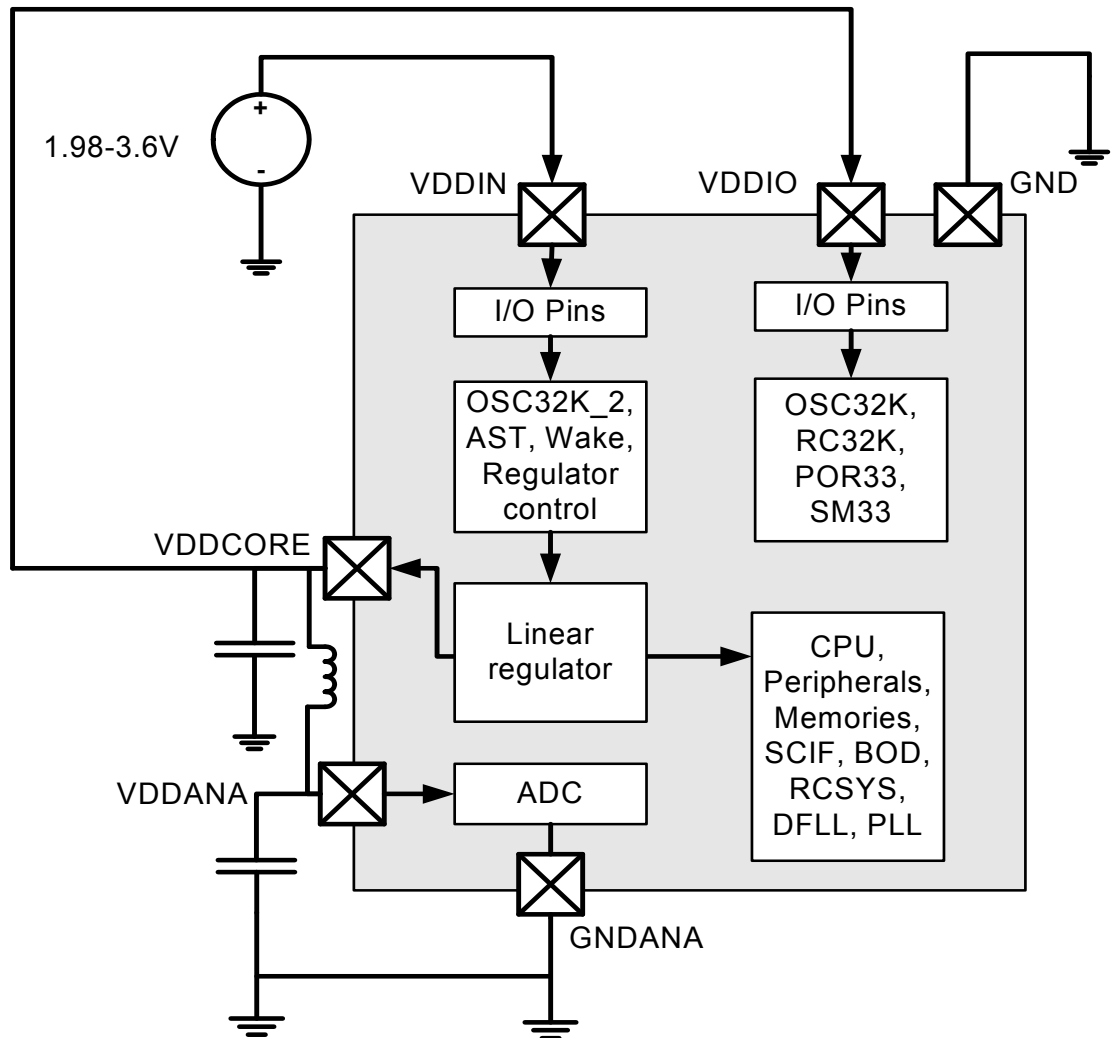

In this mode, some I/O lines are powered by VDDIN while other I/O lines are powered by VDDIO. Refer to Section 3.2.1 on page 8 for description of power supply for each I/O line.

Refer to the Power Manager chapter for a description of what parts of the system are powered in Shutdown mode.

Important note: As the regulator has a maximum output current of 60 mA, this mode can only be used in applications where the maximum I/O current is known and compatible with the core and peripheral power consumption. Typically, great care must be used to ensure that only a few I/O lines are toggling at the same time and drive very small loads.

6.1.4 Power-up Sequence

6.1.4.1 Maximum Rise Rate

To avoid risk of latch-up, the rise rate of the power supplies must not exceed the values described in [Table 7-3 on page 42](#).

Recommended order for power supplies is also described in this chapter.

6.1.4.2 Minimum Rise Rate

The integrated Power-on Reset (POR33) circuitry monitoring the VDDIN powering supply requires a minimum rise rate for the VDDIN power supply.

See [Table 7-3 on page 42](#) for the minimum rise rate value.

If the application can not ensure that the minimum rise rate condition for the VDDIN power supply is met, one of the following configurations can be used:

- A logic “0” value is applied during power-up on pin PA11 (WAKE_N) until VDDIN rises above 1.2V.
- A logic “0” value is applied during power-up on pin RESET_N until VDDIN rises above 1.2V.

6.2 Startup Considerations

This chapter summarizes the boot sequence of the AT32UC3L0128/256. The behavior after power-up is controlled by the Power Manager. For specific details, refer to the Power Manager chapter.

6.2.1 Starting of Clocks

After power-up, the device will be held in a reset state by the Power-on Reset (POR18 and POR33) circuitry for a short time to allow the power to stabilize throughout the device. After reset, the device will use the System RC Oscillator (RCSYS) as clock source. Please refer to [Table 7-17 on page 54](#) for the frequency for this oscillator.

On system start-up, all high-speed clocks are disabled. All clocks to all modules are running. No clocks have a divided frequency; all parts of the system receive a clock with the same frequency as the System RC Oscillator.

When powering up the device, there may be a delay before the voltage has stabilized, depending on the rise time of the supply used. The CPU can start executing code as soon as the supply is above the POR18 and POR33 thresholds, and before the supply is stable. Before switching to a high-speed clock source, the user should use the BOD to make sure the VDDCORE is above the minimum level (1.62V).

6.2.2 Fetching of Initial Instructions

After reset has been released, the AVR32 UC CPU starts fetching instructions from the reset address, which is 0x80000000. This address points to the first address in the internal Flash.

The code read from the internal flash is free to configure the clock system and clock sources. Please refer to the PM and SCIF chapters for more details.

7. Electrical Characteristics

7.1 Absolute Maximum Ratings*

Table 7-1. Absolute Maximum Ratings

Operating temperature.....	-40°C to +85°C
Storage temperature.....	-60°C to +150°C
Voltage on input pins (except for 5V pins) with respect to ground	-0.3V to $V_{VDD}^{(2)}$ +0.3V
Voltage on 5V tolerant ⁽¹⁾ pins with respect to ground	-0.3V to 5.5V
Total DC output current on all I/O pins - VDDIO	120mA
Total DC output current on all I/O pins - VDDIN	36mA
Maximum operating voltage VDDCORE.....	1.98V
Maximum operating voltage VDDIO, VDDIN	3.6V

*NOTICE: Stresses beyond those listed under “Absolute Maximum Ratings” may cause permanent damage to the device. This is a stress rating only and functional operation of the device at these or other conditions beyond those indicated in the operational sections of this specification is not implied. Exposure to absolute maximum rating conditions for extended periods may affect device reliability.

- Notes: 1. 5V tolerant pins, see [Section 3.2 “Peripheral Multiplexing on I/O Lines” on page 8](#)
 2. V_{VDD} corresponds to either V_{VDDIN} or V_{VDDIO} , depending on the supply for the pin. Refer to [Section 3.2 on page 8](#) for details.

7.2 Supply Characteristics

The following characteristics are applicable to the operating temperature range: $T_A = -40^\circ\text{C}$ to 85°C , unless otherwise specified and are valid for a junction temperature up to $T_J = 100^\circ\text{C}$. Please refer to [Section 6. “Supply and Startup Considerations” on page 36](#)

Table 7-2. Supply Characteristics

Symbol	Parameter	Voltage		
		Min	Max	Unit
V_{VDDIO}	DC supply peripheral I/Os	1.62	3.6	V
V_{VDDIN}	DC supply peripheral I/Os, 1.8V single supply mode	1.62	1.98	V
	DC supply peripheral I/Os and internal regulator, 3.3V supply mode	1.98	3.6	V
$V_{VDDCORE}$	DC supply core	1.62	1.98	V
V_{VDDANA}	Analog supply voltage	1.62	1.98	V

Table 7-3. Supply Rise Rates and Order⁽¹⁾

Symbol	Parameter	Rise Rate			
		Min	Max	Unit	Comment
V _{VDDIO}	DC supply peripheral I/Os	0	2.5	V/μs	
V _{VDDIN}	DC supply peripheral I/Os and internal regulator	0.002	2.5	V/μs	Slower rise time requires external power-on reset circuit.
V _{VDDCORE}	DC supply core	0	2.5	V/μs	Rise before or at the same time as VDDIO
V _{VDDANA}	Analog supply voltage	0	2.5	V/μs	Rise together with VDDCORE

Note: 1. These values are based on simulation and characterization of other AVR microcontrollers manufactured in the same process technology. These values are not covered by test limits in production.

7.3 Maximum Clock Frequencies

These parameters are given in the following conditions:

- V_{VDDCORE} = 1.62V to 1.98V
- Temperature = -40°C to 85°C

Table 7-4. Clock Frequencies

Symbol	Parameter	Description	Min	Max	Units
f _{CPU}	CPU clock frequency			50	MHz
f _{PBA}	PBA clock frequency			50	
f _{PBB}	PBB clock frequency			50	
f _{GCLK0}	GCLK0 clock frequency	DFLLIF main reference, GCLK0 pin		50	
f _{GCLK1}	GCLK1 clock frequency	DFLLIF dithering and SSG reference, GCLK1 pin		50	
f _{GCLK2}	GCLK2 clock frequency	AST, GCLK2 pin		20	
f _{GCLK3}	GCLK3 clock frequency	PWMA, GCLK3 pin		140	
f _{GCLK4}	GCLK4 clock frequency	CAT, ACIFB, GCLK4 pin		50	
f _{GCLK5}	GCLK5 clock frequency	GLOC		80	
f _{GCLK6}	GCLK6 clock frequency			50	
f _{GCLK7}	GCLK7 clock frequency			50	
f _{GCLK8}	GCLK8 clock frequency	PLL source clock		50	
f _{GCLK9}	GCLK9 clock frequency	FREQM, GCLK0-8		150	

7.4 Power Consumption

The values in [Table 7-5](#) are measured values of power consumption under the following conditions, except where noted:

- Operating conditions, internal core supply ([Figure 7-1](#)) - this is the default configuration

- $V_{VDDIN} = 3.0V$
- $V_{VDDCORE} = 1.62V$, supplied by the internal regulator
- Corresponds to the 3.3V supply mode with 1.8V regulated I/O lines, please refer to the Supply and Startup Considerations section for more details
 - Equivalent to the 3.3V single supply mode
 - Consumption in 1.8V single supply mode can be estimated by subtracting the regulator static current
- Operating conditions, external core supply (Figure 7-2) - used only when noted
 - $V_{VDDIN} = V_{VDDCORE} = 1.8V$
 - Corresponds to the 1.8V single supply mode, please refer to the Supply and Startup Considerations section for more details
- $T_A = 25^{\circ}C$
- Oscillators
 - OSC0 (crystal oscillator) stopped
 - OSC32K (32KHz crystal oscillator) running with external 32KHz crystal
 - DFLL running at 50MHz with OSC32K as reference
- Clocks
 - DFLL used as main clock source
 - CPU, HSB, and PBB clocks undivided
 - PBA clock divided by 4
 - The following peripheral clocks running
 - PM, SCIF, AST, FLASHCDW, PBA bridge
 - All other peripheral clocks stopped
- I/Os are inactive with internal pull-up
- Flash enabled in high speed mode
- POR18 enabled
- POR33 disabled

Table 7-5. Power Consumption for Different Operating Modes

Mode	Conditions	Measured on	Consumption Typ	Unit
Active ⁽¹⁾	CPU running a recursive Fibonacci algorithm	Amp0	300	$\mu\text{A}/\text{MHz}$
	CPU running a division algorithm		174	
Idle ⁽¹⁾	96			
Frozen ⁽¹⁾	57			
Standby ⁽¹⁾	46			
Stop	38			
DeepStop	25			
Static	-OSC32K and AST stopped -Internal core supply		14	μA
	-OSC32K running -AST running at 1 KHz -External core supply (Figure 7-2)		7.3	
	-OSC32K and AST stopped -External core supply (Figure 7-2)		6.7	
Shutdown	-OSC32K running -AST running at 1 KHz	800	nA	
	AST and OSC32K stopped	220		

Note: 1. These numbers are valid for the measured condition only and must not be extrapolated to other frequencies.

Figure 7-1. Measurement Schematic, Internal Core Supply

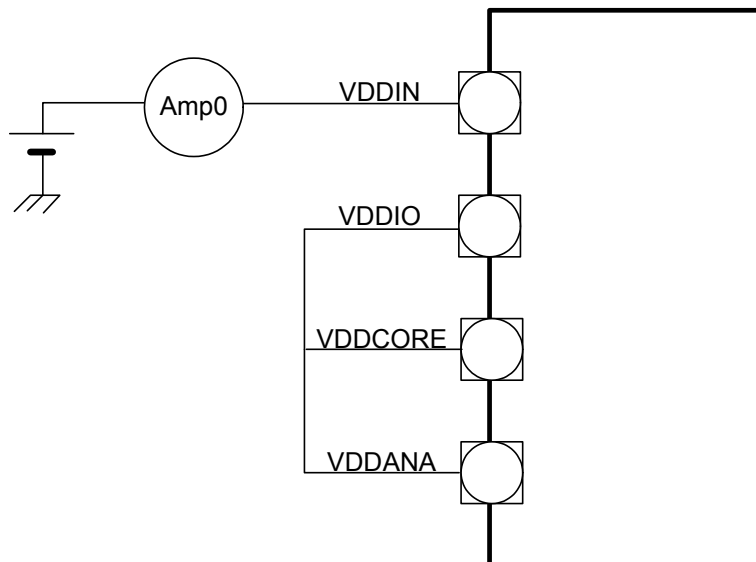
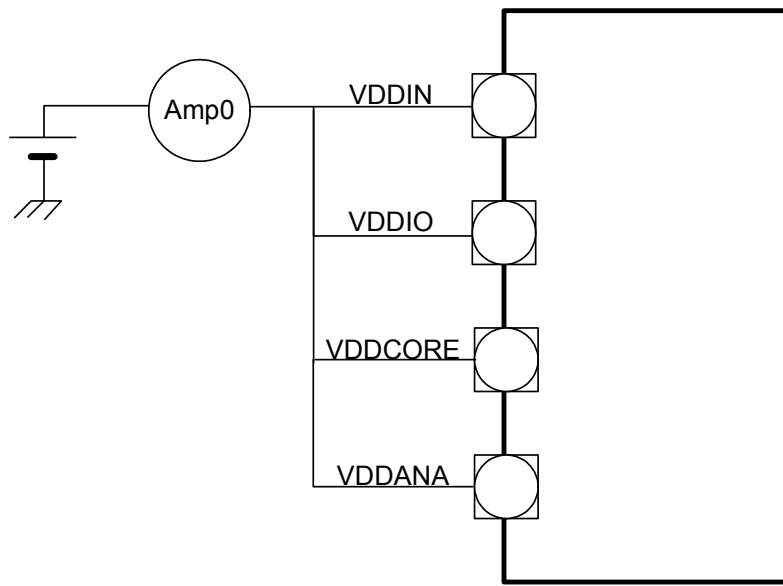

Figure 7-2. Measurement Schematic, External Core Supply



7.5 I/O Pin Characteristics

Table 7-6. Normal I/O Pin Characteristics⁽¹⁾

Symbol	Parameter	Condition	Min	Typ	Max	Units
R _{PULLUP}	Pull-up resistance		75	100	145	kOhm
V _{IL}	Input low-level voltage	V _{VDD} = 3.0V	-0.3		0.3*V _{VDD}	V
		V _{VDD} = 1.62V	-0.3		0.3*V _{VDD}	
V _{IH}	Input high-level voltage	V _{VDD} = 3.6V	0.7*V _{VDD}		V _{VDD} + 0.3	V
		V _{VDD} = 1.98V	0.7*V _{VDD}		V _{VDD} + 0.3	
V _{OL}	Output low-level voltage	V _{VDD} = 3.0V, I _{OL} = 3mA			0.4	V
		V _{VDD} = 1.62V, I _{OL} = 2mA			0.4	
V _{OH}	Output high-level voltage	V _{VDD} = 3.0V, I _{OH} = 3mA	V _{VDD} - 0.4			V
		V _{VDD} = 1.62V, I _{OH} = 2mA	V _{VDD} - 0.4			
f _{MAX}	Output frequency ⁽²⁾	V _{VDD} = 3.0V, load = 10pF			45	MHz
		V _{VDD} = 3.0V, load = 30pF			23	
t _{RISE}	Rise time ⁽²⁾	V _{VDD} = 3.0V, load = 10pF			4.7	ns
		V _{VDD} = 3.0V, load = 30pF			11.5	
t _{FALL}	Fall time ⁽²⁾	V _{VDD} = 3.0V, load = 10pF			4.8	
		V _{VDD} = 3.0V, load = 30pF			12	
I _{LEAK}	Input leakage current	Pull-up resistors disabled			1	μA
C _{IN}	Input capacitance, all normal I/O pins except PA05, PA07, PA17, PA20, PA21, PB04, PB05	TQFP48 package		1.4		pF
		QFN48 package		1.1		
		TLLGA48 package		1.1		
C _{IN}	Input capacitance, PA20	TQFP48 package		2.7		
		QFN48 package		2.4		
		TLLGA48 package		2.4		
C _{IN}	Input capacitance, PA05, PA07, PA17, PA21, PB04, PB05	TQFP48 package		3.8		
		QFN48 package		3.5		
		TLLGA48 package		3.5		

- Notes: 1. V_{VDD} corresponds to either V_{VDDIN} or V_{VDDIO}, depending on the supply for the pin. Refer to [Section 3.2.1 on page 8](#) for details.
 2. These values are based on simulation and characterization of other AVR microcontrollers manufactured in the same process technology. These values are not covered by test limits in production.

Table 7-7. High-drive I/O Pin Characteristics⁽¹⁾

Symbol	Parameter	Condition	Min	Typ	Max	Units
R _{PULLUP}	Pull-up resistance	PA06	30	50	110	kOhm
		PA02, PB01, RESET	75	100	145	
		PA08, PA09	10	20	45	

Table 7-7. High-drive I/O Pin Characteristics⁽¹⁾

Symbol	Parameter	Condition	Min	Typ	Max	Units
V _{IL}	Input low-level voltage	V _{VDD} = 3.0V	-0.3		0.3*V _{VDD}	V
		V _{VDD} = 1.62V	-0.3		0.3*V _{VDD}	
V _{IH}	Input high-level voltage	V _{VDD} = 3.6V	0.7*V _{VDD}		V _{VDD} + 0.3	V
		V _{VDD} = 1.98V	0.7*V _{VDD}		V _{VDD} + 0.3	
V _{OL}	Output low-level voltage	V _{VDD} = 3.0V, I _{OL} = 6mA			0.4	V
		V _{VDD} = 1.62V, I _{OL} = 4mA			0.4	
V _{OH}	Output high-level voltage	V _{VDD} = 3.0V, I _{OH} = 6mA	V _{VDD} -0.4			V
		V _{VDD} = 1.62V, I _{OH} = 4mA	V _{VDD} -0.4			
f _{MAX}	Output frequency, all High-drive I/O pins, except PA08 and PA09 ⁽²⁾	V _{VDD} = 3.0V, load = 10pF			45	MHz
		V _{VDD} = 3.0V, load = 30pF			23	
t _{RISE}	Rise time, all High-drive I/O pins, except PA08 and PA09 ⁽²⁾	V _{VDD} = 3.0V, load = 10pF			4.7	ns
		V _{VDD} = 3.0V, load = 30pF			11.5	
t _{FALL}	Fall time, all High-drive I/O pins, except PA08 and PA09 ⁽²⁾	V _{VDD} = 3.0V, load = 10pF			4.8	ns
		V _{VDD} = 3.0V, load = 30pF			12	
f _{MAX}	Output frequency, PA08 and PA09 ⁽²⁾	V _{VDD} = 3.0V, load = 10pF			54	MHz
		V _{VDD} = 3.0V, load = 30pF			40	
t _{RISE}	Rise time, PA08 and PA09 ⁽²⁾	V _{VDD} = 3.0V, load = 10pF			2.8	ns
		V _{VDD} = 3.0V, load = 30pF			4.9	
t _{FALL}	Fall time, PA08 and PA09 ⁽²⁾	V _{VDD} = 3.0V, load = 10pF			2.4	ns
		V _{VDD} = 3.0V, load = 30pF			4.6	
I _{LEAK}	Input leakage current	Pull-up resistors disabled			1	μA
C _{IN}	Input capacitance, all High-drive I/O pins, except PA08 and PA09	TQFP48 package		2.2		pF
		QFN48 package		2.0		
		TLLGA48 package		2.0		
C _{IN}	Input capacitance, PA08 and PA09	TQFP48 package		7.0		pF
		QFN48 package		6.7		
		TLLGA48 package		6.7		

- Notes: 1. V_{VDD} corresponds to either V_{VDDIN} or V_{VDDIO}, depending on the supply for the pin. Refer to [Section 3.2.1 on page 8](#) for details.
 2. These values are based on simulation and characterization of other AVR microcontrollers manufactured in the same process technology. These values are not covered by test limits in production.

Table 7-8. High-drive I/O, 5V Tolerant, Pin Characteristics⁽¹⁾

Symbol	Parameter	Condition	Min	Typ	Max	Units
R _{PULLUP}	Pull-up resistance		30	50	110	kOhm
V _{IL}	Input low-level voltage	V _{VDD} = 3.0V	-0.3		0.3*V _{VDD}	V
		V _{VDD} = 1.62V	-0.3		0.3*V _{VDD}	

Table 7-8. High-drive I/O, 5V Tolerant, Pin Characteristics⁽¹⁾

Symbol	Parameter	Condition	Min	Typ	Max	Units
V _{IH}	Input high-level voltage	V _{VDD} = 3.6V	0.7*V _{VDD}		5.5	V
		V _{VDD} = 1.98V	0.7*V _{VDD}		5.5	
V _{OL}	Output low-level voltage	V _{VDD} = 3.0V, I _{OL} = 6mA			0.4	V
		V _{VDD} = 1.62V, I _{OL} = 4mA			0.4	
V _{OH}	Output high-level voltage	V _{VDD} = 3.0V, I _{OH} = 6mA	V _{VDD} -0.4			V
		V _{VDD} = 1.62V, I _{OH} = 4mA	V _{VDD} -0.4			
f _{MAX}	Output frequency ⁽²⁾	V _{VDD} = 3.0V, load = 10pF			87	MHz
		V _{VDD} = 3.0V, load = 30pF			58	
t _{RISE}	Rise time ⁽²⁾	V _{VDD} = 3.0V, load = 10pF			2.3	ns
		V _{VDD} = 3.0V, load = 30pF			4.3	
t _{FALL}	Fall time ⁽²⁾	V _{VDD} = 3.0V, load = 10pF			1.9	
		V _{VDD} = 3.0V, load = 30pF			3.7	
I _{LEAK}	Input leakage current	5.5V, pull-up resistors disabled			10	μA
C _{IN}	Input capacitance	TQFP48 package		4.5		pF
		QFN48 package		4.2		
		TLLGA48 package		4.2		

- Notes: 1. V_{VDD} corresponds to either V_{VDDIN} or V_{VDDIO}, depending on the supply for the pin. Refer to [Section 3.2.1 on page 8](#) for details.
 2. These values are based on simulation and characterization of other AVR microcontrollers manufactured in the same process technology. These values are not covered by test limits in production.

Table 7-9. TWI Pin Characteristics⁽¹⁾

Symbol	Parameter	Condition	Min	Typ	Max	Units
R _{PULLUP}	Pull-up resistance		25	35	60	kOhm
V _{IL}	Input low-level voltage	V _{VDD} = 3.0V	-0.3		0.3*V _{VDD}	V
		V _{VDD} = 1.62V	-0.3		0.3*V _{VDD}	
V _{IH}	Input high-level voltage	V _{VDD} = 3.6V	0.7*V _{VDD}		V _{VDD} + 0.3	V
		V _{VDD} = 1.98V	0.7*V _{VDD}		V _{VDD} + 0.3	
	Input high-level voltage, 5V tolerant SMBUS compliant pins	V _{VDD} = 3.6V	0.7*V _{VDD}		5.5	V
		V _{VDD} = 1.98V	0.7*V _{VDD}		5.5	
V _{OL}	Output low-level voltage	I _{OL} = 3mA			0.4	V
I _{LEAK}	Input leakage current	Pull-up resistors disabled			1	μA
I _{IL}	Input low leakage				1	
I _{IH}	Input high leakage				1	
C _{IN}	Input capacitance	TQFP48 package		3.8		pF
		QFN48 package		3.5		
		TLLGA48 package		3.5		

Table 7-9. TWI Pin Characteristics⁽¹⁾

Symbol	Parameter	Condition	Min	Typ	Max	Units
t _{FALL}	Fall time	Cbus = 400pF, V _{VDD} > 2.0V		250		ns
		Cbus = 400pF, V _{VDD} > 1.62V		470		
f _{MAX}	Max frequency	Cbus = 400pF, V _{VDD} > 2.0V	400			kHz

Note: 1. V_{VDD} corresponds to either V_{VDDIN} or V_{VDDIO}, depending on the supply for the pin. Refer to [Section 3.2.1 on page 8](#) for details.

7.6 Oscillator Characteristics

7.6.1 Oscillator 0 (OSC0) Characteristics

7.6.1.1 Digital Clock Characteristics

The following table describes the characteristics for the oscillator when a digital clock is applied on XIN.

Table 7-10. Digital Clock Characteristics

Symbol	Parameter	Conditions	Min	Typ	Max	Units
f _{CPXIN}	XIN clock frequency				50	MHz
t _{CPXIN}	XIN clock duty cycle ⁽¹⁾		40		60	%
t _{STARTUP}	Startup time			0		cycles
C _{IN}	XIN input capacitance	TQFP48 package		7.0		pF
		QFN48 package		6.7		
		TLLGA48 package		6.7		

Note: 1. These values are based on simulation and characterization of other AVR microcontrollers manufactured in the same process technology. These values are not covered by test limits in production.

7.6.1.2 Crystal Oscillator Characteristics

The following table describes the characteristics for the oscillator when a crystal is connected between XIN and XOUT as shown in [Figure 7-3](#). The user must choose a crystal oscillator where the crystal load capacitance C_L is within the range given in the table. The exact value of C_L can be found in the crystal datasheet. The capacitance of the external capacitors (C_{LEXT}) can then be computed as follows:

$$C_{LEXT} = 2(C_L - C_i) - C_{PCB}$$

where C_{PCB} is the capacitance of the PCB and C_i is the internal equivalent load capacitance.

Table 7-11. Crystal Oscillator Characteristics

Symbol	Parameter	Conditions	Min	Typ	Max	Unit
f_{OUT}	Crystal oscillator frequency ⁽³⁾		0.45	10	16	MHz
C_L	Crystal load capacitance ⁽³⁾		6		18	pF
C_i	Internal equivalent load capacitance			2		
$t_{STARTUP}$	Startup time	SCIF.OSCCTRL.GAIN = 2 ⁽¹⁾		30 000 ⁽²⁾		cycles
I_{OSC}	Current consumption	Active mode, $f = 0.45\text{MHz}$, SCIF.OSCCTRL.GAIN = 0		30		μA
		Active mode, $f = 10\text{MHz}$, SCIF.OSCCTRL.GAIN = 2		220		

- Notes:
1. Please refer to the SCIF chapter for details.
 2. Nominal crystal cycles.
 3. These values are based on simulation and characterization of other AVR microcontrollers manufactured in the same process technology. These values are not covered by test limits in production.

Figure 7-3. Oscillator Connection

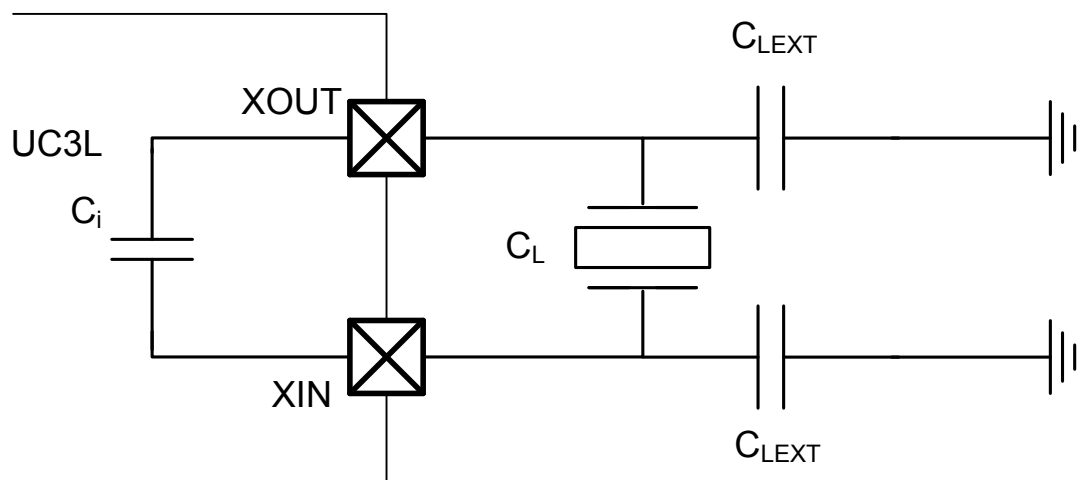

7.6.2 32KHz Crystal Oscillator (OSC32K) Characteristics

Figure 7-3 and the equation above also applies to the 32KHz oscillator connection. The user must choose a crystal oscillator where the crystal load capacitance C_L is within the range given in the table. The exact value of C_L can then be found in the crystal datasheet.

Table 7-12. 32 KHz Crystal Oscillator Characteristics

Symbol	Parameter	Conditions	Min	Typ	Max	Unit
f_{OUT}	Crystal oscillator frequency			32 768		Hz
$t_{STARTUP}$	Startup time	$R_S = 60k\Omega, C_L = 9pF$		30 000 ⁽¹⁾		cycles
C_L	Crystal load capacitance ⁽²⁾		6		12.5	pF
C_i	Internal equivalent load capacitance			2		
I_{OSC32}	Current consumption			0.6		μA
R_S	Equivalent series resistance ⁽²⁾	32 768Hz	35		85	k Ω

- Notes:
1. Nominal crystal cycles.
 2. These values are based on simulation and characterization of other AVR microcontrollers manufactured in the same process technology. These values are not covered by test limits in production.

7.6.3 Phase Locked Loop (PLL) Characteristics

Table 7-13. Phase Locked Loop Characteristics

Symbol	Parameter	Conditions	Min	Typ	Max	Unit
f_{OUT}	Output frequency ⁽¹⁾		40		240	MHz
f_{IN}	Input frequency ⁽¹⁾		4		16	
I_{PLL}	Current consumption			8		$\mu A/MHz$
$t_{STARTUP}$	Startup time, from enabling the PLL until the PLL is locked	$f_{IN} = 4MHz$		200		μs
		$f_{IN} = 16MHz$		155		

- Note:
1. These values are based on simulation and characterization of other AVR microcontrollers manufactured in the same process technology. These values are not covered by test limits in production.

7.6.4 Digital Frequency Locked Loop (DFLL) Characteristics

Table 7-14. Digital Frequency Locked Loop Characteristics

Symbol	Parameter	Conditions	Min	Typ	Max	Unit
f_{OUT}	Output frequency ⁽²⁾		20		150	MHz
f_{REF}	Reference frequency ⁽²⁾		8		150	kHz
	FINE resolution step	FINE > 100, all COARSE values ⁽³⁾		0.38		%
	Frequency drift over voltage and temperature	Open loop mode		See Figure 7-4		
	Accuracy ⁽²⁾	FINE lock, $f_{REF} = 32\text{kHz}$, SSG disabled		0.1	0.5	%
		ACCURATE lock, $f_{REF} = 32\text{kHz}$, dither clk RCSYS/2, SSG disabled		0.06	0.5	
		FINE lock, $f_{REF} = 8\text{-}150\text{kHz}$, SSG disabled		0.2	1	
		ACCURATE lock, $f_{REF} = 8\text{-}150\text{kHz}$, dither clk RCSYS/2, SSG disabled		0.1	1	
I_{DFLL}	Power consumption			25		$\mu\text{A}/\text{MHz}$
$t_{STARTUP}$	Startup time ⁽²⁾	Within 90% of final values			100	μs
t_{LOCK}	Lock time	$f_{REF} = 32\text{kHz}$, FINE lock, SSG disabled		8		ms
		$f_{REF} = 32\text{kHz}$, ACCURATE lock, dithering clock = RCSYS/2, SSG disabled		28		

- Notes:
1. Spread Spectrum Generator (SSG) is disabled by writing a zero to the EN bit in the DFLL0SSG register.
 2. These values are based on simulation and characterization of other AVR microcontrollers manufactured in the same process technology. These values are not covered by test limits in production.
 3. The FINE and COARSE values are selected by writing to the DFLL0VAL.FINE and DFLL0VAL.COARSE field respectively.

Figure 7-4. DFLL Open Loop Frequency Variation⁽¹⁾⁽²⁾

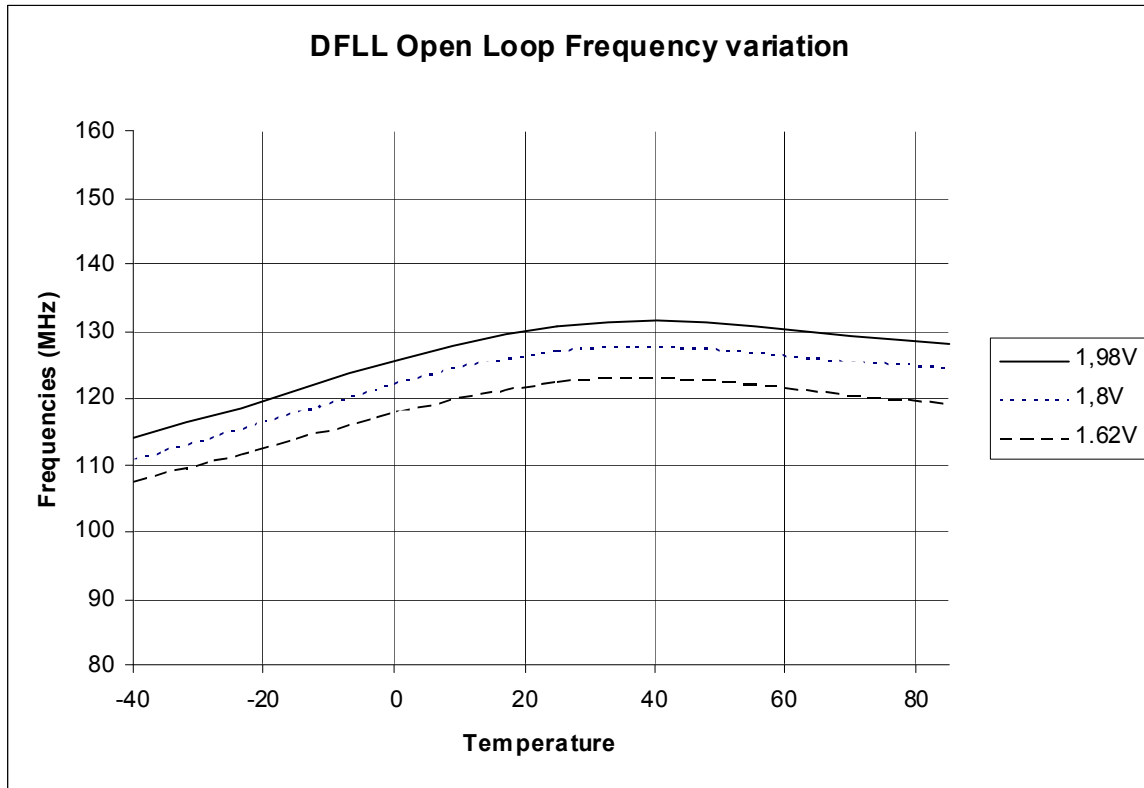

- Notes: 1. The plot shows a typical open loop mode behavior with COARSE= 99 and FINE= 255
 2. These values are based on simulation and characterization of other AVR microcontrollers manufactured in the same process technology. These values are not covered by test limits in production.

7.6.5 120MHz RC Oscillator (RC120M) Characteristics

Table 7-15. Internal 120MHz RC Oscillator Characteristics

Symbol	Parameter	Conditions	Min	Typ	Max	Unit
f _{OUT}	Output frequency ⁽¹⁾		88	120	152	MHz
I _{RC120M}	Current consumption			1.2		mA
t _{STARTUP}	Startup time ⁽¹⁾	V _{VDDCORE} = 1.8V		3		μs

- Note: 1. These values are based on simulation and characterization of other AVR microcontrollers manufactured in the same process technology. These values are not covered by test limits in production.

7.6.6 32kHz RC Oscillator (RC32K) Characteristics

Table 7-16. 32kHz RC Oscillator Characteristics

Symbol	Parameter	Conditions	Min	Typ	Max	Unit
f_{OUT}	Output frequency ⁽¹⁾		20	32	44	kHz
I_{RC32K}	Current consumption			0.7		μA
$t_{STARTUP}$	Startup time ⁽¹⁾			100		μs

Note: 1. These values are based on simulation and characterization of other AVR microcontrollers manufactured in the same process technology. These values are not covered by test limits in production.

7.6.7 System RC Oscillator (RCSYS) Characteristics

Table 7-17. System RC Oscillator Characteristics

Symbol	Parameter	Conditions	Min	Typ	Max	Unit
f_{OUT}	Output frequency	Calibrated at 85°C	111.6	115	118.4	kHz

7.7 Flash Characteristics

Table 7-18 gives the device maximum operating frequency depending on the number of flash wait states and the flash read mode. The FSW bit in the FLASHCDW FSR register controls the number of wait states used when accessing the flash memory.

Table 7-18. Maximum Operating Frequency

Flash Wait States	Read Mode	Maximum Operating Frequency
1	High speed read mode	50MHz
0		25MHz
1	Normal read mode	30MHz
0		15MHz

Table 7-19. Flash Characteristics

Symbol	Parameter	Conditions	Min	Typ	Max	Unit
t_{FPP}	Page programming time	$f_{CLK_HSB} = 50MHz$		5		ms
t_{FPE}	Page erase time			5		
t_{FFP}	Fuse programming time			1		
t_{FEA}	Full chip erase time (EA)			6		
t_{FCE}	JTAG chip erase time (CHIP_ERASE)	$f_{CLK_HSB} = 115kHz$		310		

Table 7-20. Flash Endurance and Data Retention

Symbol	Parameter	Conditions	Min	Typ	Max	Unit
N_{FARRAY}	Array endurance (write/page)		100k			cycles
N_{FFUSE}	General Purpose fuses endurance (write/bit)		10k			
t_{RET}	Data retention		15			years

7.8 Analog Characteristics

7.8.1 Voltage Regulator Characteristics

Table 7-21. VREG Electrical Characteristics

Symbol	Parameter	Condition	Min	Typ	Max	Units
V_{VDDIN}	Input voltage range		1.98	3.3	3.6	V
$V_{VDDCORE}$	Output voltage, calibrated value	$V_{VDDIN} \geq 1.98V$		1.8		
	Output voltage accuracy ⁽¹⁾	$I_{OUT} = 0.1mA \text{ to } 60mA,$ $V_{VDDIN} > 1.98V$		2		%
		$I_{OUT} = 0.1mA \text{ to } 60mA,$ $V_{VDDIN} < 1.98V$		4		
I_{OUT}	DC output current ⁽¹⁾	Normal mode			60	mA
		Low power mode			1	
I_{VREG}	Static current of internal regulator	Normal mode		13		μA
		Low power mode		4		

Note: 1. These values are based on simulation and characterization of other AVR microcontrollers manufactured in the same process technology. These values are not covered by test limits in production.

Table 7-22. Decoupling Requirements

Symbol	Parameter	Condition	Typ	Techno.	Units
C_{IN1}	Input regulator capacitor 1		33		nF
C_{IN2}	Input regulator capacitor 2		100		
C_{IN3}	Input regulator capacitor 3		10		μF
C_{OUT1}	Output regulator capacitor 1		100		nF
C_{OUT2}	Output regulator capacitor 2		2.2	Tantalum $0.5 < ESR < 10\Omega$	μF

Note: 1. Refer to [Section 6.1.2 on page 36](#).

7.8.2 Power-on Reset 18 Characteristics

Table 7-23. POR18 Characteristics

Symbol	Parameter	Condition	Min	Typ	Max	Units
V_{POT+}	Voltage threshold on $V_{VDDCORE}$ rising			1.45	1.58	V
V_{POT-}	Voltage threshold on $V_{VDDCORE}$ falling		1.2	1.32		
t_{DET}	Detection time ⁽¹⁾	Time with $V_{VDDCORE} < V_{POT-}$ necessary to generate a reset signal		460		μs
I_{POR18}	Current consumption			4		μA
$t_{STARTUP}$	Startup time ⁽¹⁾			6		μs

Note: 1. These values are based on simulation and characterization of other AVR microcontrollers manufactured in the same process technology. These values are not covered by test limits in production.

Figure 7-5. POR18 Operating Principle

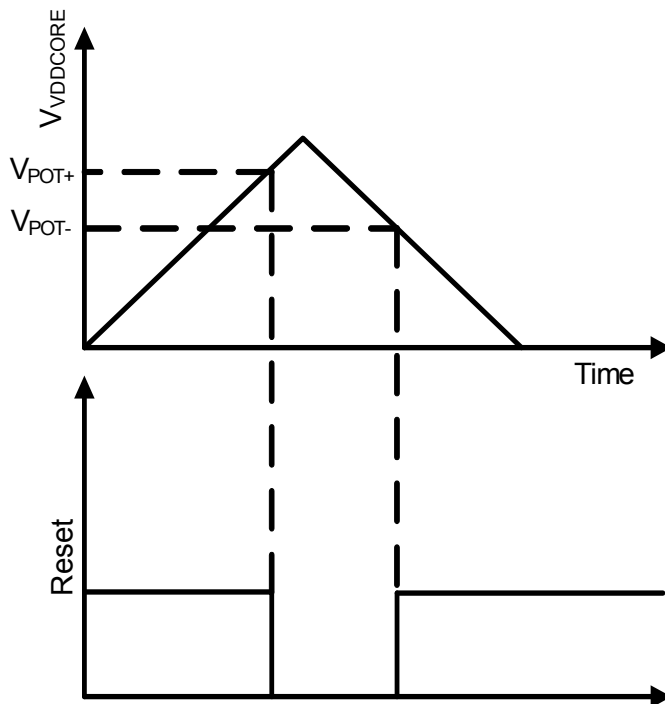

7.8.3 Power-on Reset 33 Characteristics

Table 7-24. POR33 Characteristics

Symbol	Parameter	Condition	Min	Typ	Max	Units
V_{POT+}	Voltage threshold on V_{DDIN} rising		1.3	1.49	1.58	V
V_{POT-}	Voltage threshold on V_{DDIN} falling			1.45		
t_{DET}	Detection time ⁽¹⁾	Time with $V_{DDIN} < V_{POT-}$ necessary to generate a reset signal		460		μs
I_{POR33}	Current consumption			20		μA
$t_{STARTUP}$	Startup time ⁽¹⁾			400		μs

Note: 1. These values are based on simulation and characterization of other AVR microcontrollers manufactured in the same process technology. These values are not covered by test limits in production.

Figure 7-6. POR33 Operating Principle

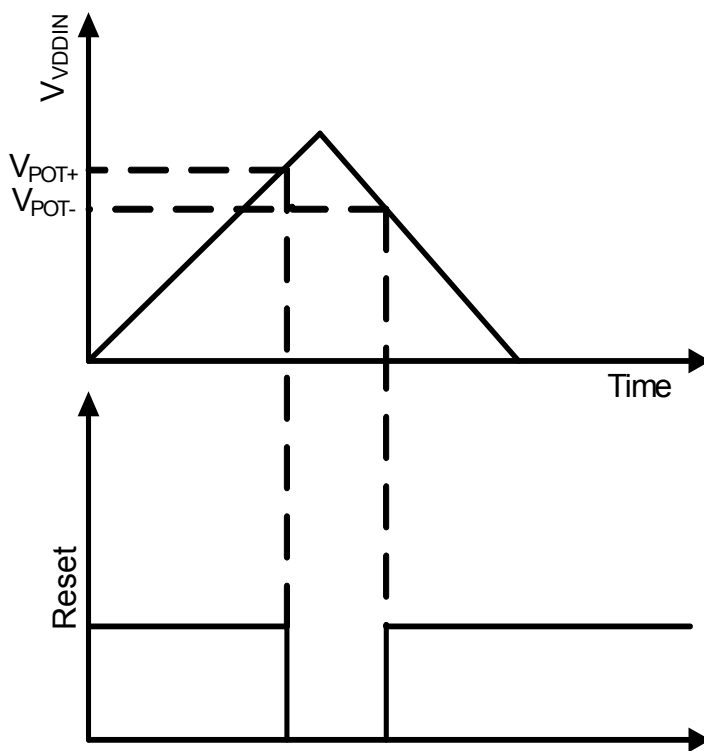

7.8.4 Brown Out Detector Characteristics

The values in [Table 7-25](#) describe the values of the BODLEVEL in the flash General Purpose Fuse register.

Table 7-25. BODLEVEL Values

BODLEVEL Value	Min	Typ	Max	Units
011111 binary (31) 0x1F		1.60		V
100111 binary (39) 0x27		1.69		

Table 7-26. BOD Characteristics

Symbol	Parameter	Condition	Min	Typ	Max	Units
V_{HYST}	BOD hysteresis	$T = 25^{\circ}C$		10		mV
t_{DET}	Detection time	Time with $V_{DDCORE} < BODLEVEL$ necessary to generate a reset signal		1		μs
I_{BOD}	Current consumption			7		μA
$t_{STARTUP}$	Startup time			5		μs

7.8.5 Supply Monitor 33 Characteristics

Table 7-27. SM33 Characteristics

Symbol	Parameter	Condition	Min	Typ	Max	Units
V_{TH}	Voltage threshold	Calibrated ⁽¹⁾ , $T = 25^{\circ}C$	1.675	1.75	1.825	V
	Step size, between adjacent values in SCIF.SM33.CALIB ⁽²⁾			11		mV
V_{HYST}	Hysteresis ⁽²⁾			30		
t_{DET}	Detection time	Time with $V_{DDIN} < V_{TH}$ necessary to generate a reset signal		280		μs
I_{SM33}	Current consumption	Normal mode		17		μA
$t_{STARTUP}$	Startup time	Normal mode		140		μs

- Notes:
1. Calibration value can be read from the SM33.CALIB field. This field is updated by the flash fuses after a reset. Refer to SCIF chapter for details.
 2. These values are based on simulation and characterization of other AVR microcontrollers manufactured in the same process technology. These values are not covered by test limits in production.

7.8.6 Analog to Digital Converter Characteristics

Table 7-28. ADC Characteristics

Symbol	Parameter	Conditions	Min	Typ	Max	Units
f_{ADC}	ADC clock frequency	12-bit resolution mode			6	MHz
f_{ADC}	ADC clock frequency	10-bit resolution mode			6	MHz
		8-bit resolution mode			6	
$t_{STARTUP}$	Startup time	Return from Idle Mode		15		μ s
t_{CONV}	Conversion time (latency)	$f_{ADC} = 6\text{MHz}$	11		26	cycles
	Throughput rate	$V_{VDD} > 3.0\text{V}$, $f_{ADC} = 6\text{MHz}$, 12-bit resolution mode, low impedance source			28	kSPS
	Throughput rate	$V_{VDD} > 3.0\text{V}$, $f_{ADC} = 6\text{MHz}$, 10-bit resolution mode, low impedance source			460	kSPS
		$V_{VDD} > 3.0\text{V}$, $f_{ADC} = 6\text{MHz}$, 8-bit resolution mode, low impedance source			460	
$V_{ADVREFP}$	Reference voltage range	$V_{ADVREFP} = V_{VDDANA}$	1.62		1.98	V
I_{ADC}	Current consumption on V_{VDDANA}	ADC Clock = 6MHz		350		μ A
$I_{ADVREFP}$	Current consumption on ADVREFP pin	$f_{ADC} = 6\text{MHz}$		150		

Note: These values are based on simulation and characterization of other AVR microcontrollers manufactured in the same process technology. These values are not covered by test limits in production.

7.8.6.1 Inputs and Sample and Hold Acquisition Times

Table 7-29. Analog Inputs

Symbol	Parameter	Conditions	Min	Typ	Max	Units
V_{ADn}	Input Voltage Range	12-bit mode	0		$V_{ADVREFP}$	V
		10-bit mode				
		8-bit mode				
C_{ONCHIP}	Internal Capacitance ⁽¹⁾				22.5	pF
R_{ONCHIP}	Internal Resistance ⁽¹⁾	$V_{VDDIO} = 3.0\text{V to } 3.6\text{V}$, $V_{VDDCORE} = 1.8\text{V}$			3.15	kOhm
		$V_{VDDIO} = V_{VDDCORE} = 1.62\text{V to } 1.98\text{V}$			55.9	

Note: 1. These values are based on simulation and characterization of other AVR microcontrollers manufactured in the same process technology. These values are not covered by test limits in production.

The analog voltage source must be able to charge the sample and hold (S/H) capacitor in the ADC in order to achieve maximum accuracy. Seen externally the ADC input consists of a resistor (R_{ONCHIP}) and a capacitor (C_{ONCHIP}). In addition, the resistance (R_{SOURCE}) and capacitance (C_{SOURCE}) of the PCB and source must be taken into account when calculating the required sample and hold time. Figure 7-7 shows the ADC input channel equivalent circuit.



Figure 7-7. ADC Input

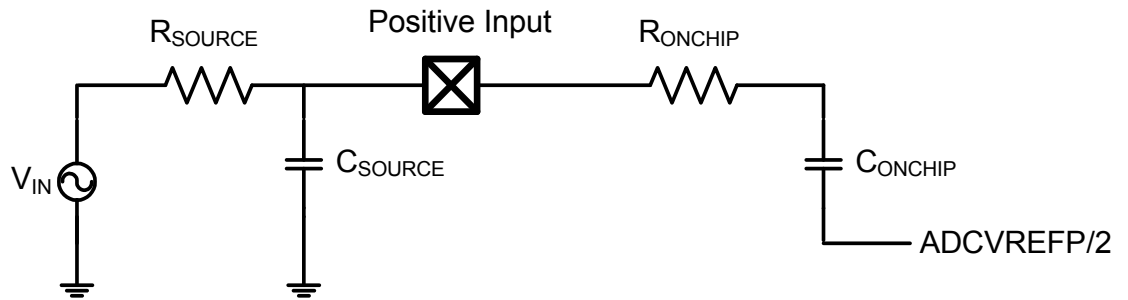

The minimum sample and hold time (in ns) can be found using this formula:

$$t_{SAMPLEHOLD} \geq (R_{ONCHIP} + R_{SOURCE}) \times (C_{ONCHIP} + C_{SOURCE}) \times \ln(2^{n+1})$$

Where n is the number of bits in the conversion. $t_{SAMPLEHOLD}$ is defined by the SHTIM field in the ADCIFB ACR register. Please refer to the ADCIFB chapter for more information.

7.8.6.2 Applicable Conditions and Derating Data

Table 7-30. Transfer Characteristics 12-bit Resolution Mode⁽¹⁾

Parameter	Conditions	Min	Typ	Max	Units
Resolution			12		Bit
Integral non-linearity	ADC clock frequency = 6MHz, Input Voltage Range = 0 - V _{ADVREFP}		+/-4		LSB
	ADC clock frequency = 6MHz, Input Voltage Range = (10% V _{ADVREFP}) - (90% V _{ADVREFP})		+/-2		
Differential non-linearity		-1.5		1.5	
Offset error	ADC clock frequency = 6MHz		+/-3		
Gain error			+/-5		

Note: 1. These values are based on simulation and characterization of other AVR microcontrollers manufactured in the same process technology. These values are not covered by test limits in production.

Table 7-31. Transfer Characteristics, 10-bit Resolution Mode⁽¹⁾

Parameter	Conditions	Min	Typ	Max	Units
Resolution			10		Bit
Integral non-linearity	ADC clock frequency = 6MHz		+/-1		LSB
Differential non-linearity		-1		1	
Offset error			+/-1		
Gain error			+/-2		

Note: 1. These values are based on simulation and characterization of other AVR microcontrollers manufactured in the same process technology. These values are not covered by test limits in production.

Table 7-32. Transfer Characteristics, 8-bit Resolution Mode⁽¹⁾

Parameter	Conditions	Min	Typ	Max	Units
Resolution			8		Bit
Integral non-linearity	ADC clock frequency = 6MHz		+/-0.5		LSB
Differential non-linearity		-0.3		0.3	
Offset error			+/-1		
Gain error			+/-1		

Note: 1. These values are based on simulation and characterization of other AVR microcontrollers manufactured in the same process technology. These values are not covered by test limits in production.

7.8.7 Temperature Sensor Characteristics

Table 7-33. Temperature Sensor Characteristics⁽¹⁾

Symbol	Parameter	Condition	Min	Typ	Max	Units
	Gradient			1		mV/°C
I _{TS}	Current consumption			1		µA
t _{STARTUP}	Startup time			0		µs

Note: 1. The Temperature Sensor is not calibrated. The accuracy of the Temperature Sensor is governed by the ADC accuracy.

7.8.8 Analog Comparator Characteristics

Table 7-34. Analog Comparator Characteristics

Symbol	Parameter	Condition	Min	Typ	Max	Units
	Positive input voltage range ⁽³⁾		-0.2		V _{VDDIO} + 0.3	V
	Negative input voltage range ⁽³⁾		-0.2		V _{VDDIO} - 0.6	
	Statistical offset ⁽³⁾	V _{ACREFN} = 1.0V, f _{AC} = 12MHz, filter length = 2, hysteresis = 0 ⁽¹⁾		20		mV
f _{AC}	Clock frequency for GCLK4 ⁽³⁾				12	MHz
	Throughput rate ⁽³⁾	f _{AC} = 12MHz			12 000 000	Comparisons per second
	Propagation delay	Delay from input change to Interrupt Status Register Changes		$\left(\left\lfloor \frac{1}{t_{CLKACIFB} \times f_{AC}} \right\rfloor + 3 \right) \times t_{CLKACIFB}$		ns
I _{AC}	Current consumption ⁽³⁾	All channels, VDDIO = 3.3V, f _A = 3MHz		420		μA
t _{STARTUP}	Startup time			3		cycles
	Input current per pin ⁽³⁾			0.2		μA/MHz ⁽²⁾

- Notes:
1. AC.CONFn.FLEN and AC.CONFn.HYS fields, refer to the Analog Comparator Interface chapter.
 2. Referring to f_{AC}.
 3. These values are based on simulation and characterization of other AVR microcontrollers manufactured in the same process technology. These values are not covered by test limits in production.

7.8.9 Capacitive Touch Characteristics

7.8.9.1 Discharge Current Source

Table 7-35. DICS Characteristics

Symbol	Parameter	Min	Typ	Max	Unit
R _{REF}	Internal resistor		170		kOhm
k	Trim step size ⁽¹⁾		0.7		%

- Note:
1. These values are based on simulation and characterization of other AVR microcontrollers manufactured in the same process technology. These values are not covered by test limits in production.

7.8.9.2 Strong Pull-up Pull-down

Table 7-36. Strong Pull-up Pull-down

Parameter	Min	Typ	Max	Unit
Pull-down resistor		1		kOhm
Pull-up resistor		1		

7.9 Timing Characteristics

7.9.1 Startup, Reset, and Wake-up Timing

The startup, reset, and wake-up timings are calculated using the following formula:

$$t = t_{CONST} + N_{CPU} \times t_{CPU}$$

Where t_{CONST} and N_{CPU} are found in [Table 7-37](#). t_{CPU} is the period of the CPU clock. If a clock source other than RCSYS is selected as the CPU clock, the oscillator startup time, $t_{OSCSTART}$, must be added to the wake-up time from the stop, deepstop, and static sleep modes. Please refer to the source for the CPU clock in the ["Oscillator Characteristics"](#) on [page 49](#) for more details about oscillator startup times.

Table 7-37. Maximum Reset and Wake-up Timing⁽¹⁾

Parameter		Measuring	Max t_{CONST} (in μ s)	Max N_{CPU}
Startup time from power-up, using regulator		Time from VDDIN crossing the V_{POT+} threshold of POR33 to the first instruction entering the decode stage of CPU. VDDCORE is supplied by the internal regulator.	2210	0
Startup time from power-up, no regulator		Time from VDDIN crossing the V_{POT+} threshold of POR33 to the first instruction entering the decode stage of CPU. VDDCORE is connected to VDDIN.	1810	0
Startup time from reset release		Time from releasing a reset source (except POR18, POR33, and SM33) to the first instruction entering the decode stage of CPU.	170	0
Wake-up	Idle	From wake-up event to the first instruction of an interrupt routine entering the decode stage of the CPU.	0	19
	Frozen		0	110
	Standby		0	110
	Stop		$27 + t_{OSCSTART}$	116
	Deepstop		$27 + t_{OSCSTART}$	116
	Static		$97 + t_{OSCSTART}$	116
Wake-up from shutdown		From wake-up event to the first instruction entering the decode stage of the CPU.	1180	0

Note: 1. These values are based on simulation and characterization of other AVR microcontrollers manufactured in the same process technology. These values are not covered by test limits in production.

7.9.2 RESET_N Timing

Table 7-38. RESET_N Waveform Parameters⁽¹⁾

Symbol	Parameter	Conditions	Min	Max	Units
t_{RESET}	RESET_N minimum pulse length		10		ns

Note: 1. These values are based on simulation and characterization of other AVR microcontrollers manufactured in the same process technology. These values are not covered by test limits in production.

7.9.3 USART in SPI Mode Timing

7.9.3.1 Master mode

Figure 7-8. USART in SPI Master Mode with (CPOL= CPHA= 0) or (CPOL= CPHA= 1)

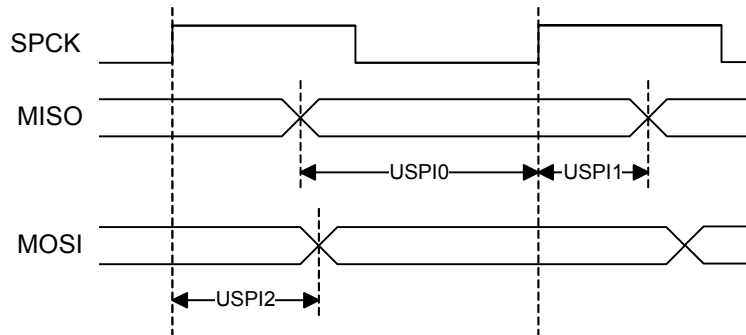

Figure 7-9. USART in SPI Master Mode with (CPOL= 0 and CPHA= 1) or (CPOL= 1 and CPHA= 0)

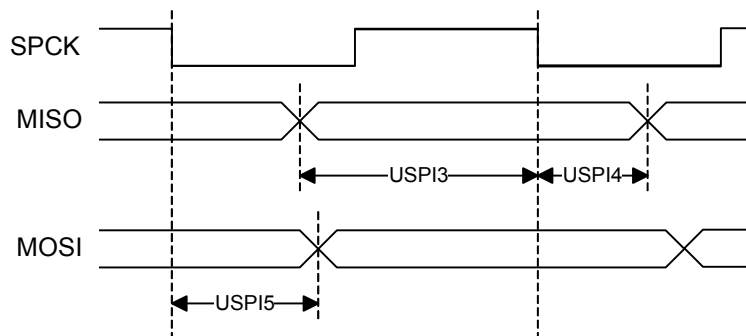

Table 7-39. USART in SPI Mode Timing, Master Mode⁽¹⁾

Symbol	Parameter	Conditions	Min	Max	Units
USPI0	MISO setup time before SPCK rises	V _{VDDIO} from 3.0V to 3.6V, maximum external capacitor = 40pF	28.7 + t _{SAMPLE} ⁽²⁾		ns
USPI1	MISO hold time after SPCK rises		0		
USPI2	SPCK rising to MOSI delay			16.5	
USPI3	MISO setup time before SPCK falls		25.8 + t _{SAMPLE} ⁽²⁾		
USPI4	MISO hold time after SPCK falls		0		
USPI5	SPCK falling to MOSI delay			21.19	

Notes: 1. These values are based on simulation and characterization of other AVR microcontrollers manufactured in the same process technology. These values are not covered by test limits in production.

2. Where: $t_{SAMPLE} = t_{SPCK} - \left(\left[\frac{t_{SPCK}}{2 \times t_{CLKUSART}} \right] \frac{1}{2} \right) \times t_{CLKUSART}$

Maximum SPI Frequency, Master Output

The maximum SPI master output frequency is given by the following formula:

$$f_{SPCKMAX} = \text{MIN}(f_{PINMAX} \cdot \frac{1}{SPI_{in}}, \frac{f_{CLKSPI} \times 2}{9})$$

Where SPI_{in} is the MOSI delay, USPI2 or USPI5 depending on CPOL and NCPHA. f_{PINMAX} is the maximum frequency of the SPI pins. Please refer to the I/O Pin Characteristics section for the maximum frequency of the pins. f_{CLKSPI} is the maximum frequency of the CLK_SPI. Refer to the SPI chapter for a description of this clock.

Maximum SPI Frequency, Master Input

The maximum SPI master input frequency is given by the following formula:

$$f_{SPCKMAX} = \text{MIN}(\frac{1}{SPI_{in} + t_{VALID}}, \frac{f_{CLKSPI} \times 2}{9})$$

Where SPI_{in} is the MISO setup and hold time, USPI0 + USPI1 or USPI3 + USPI4 depending on CPOL and NCPHA. t_{VALID} is the SPI slave response time. Please refer to the SPI slave datasheet for $t_{VALID} \cdot f_{CLKSPI}$ is the maximum frequency of the CLK_SPI. Refer to the SPI chapter for a description of this clock.

7.9.3.2 Slave mode

Figure 7-10. USART in SPI Slave Mode with (CPOL= 0 and CPHA= 1) or (CPOL= 1 and CPHA= 0)

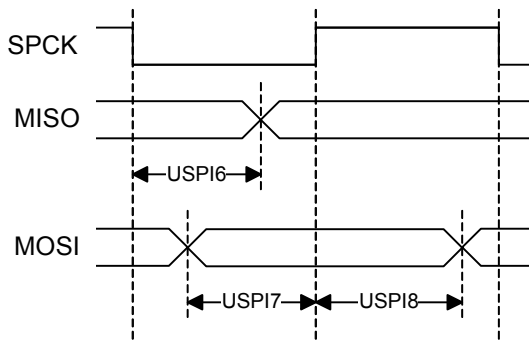

Figure 7-11. USART in SPI Slave Mode with (CPOL= CPHA= 0) or (CPOL= CPHA= 1)

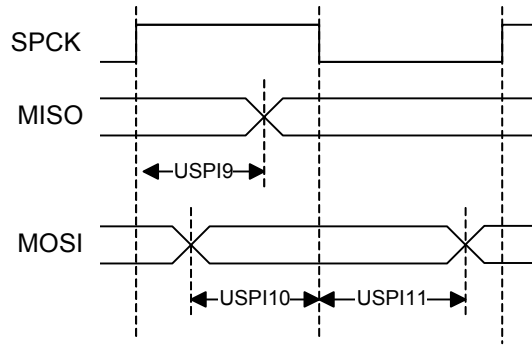

Figure 7-12. USART in SPI Slave Mode, NPCS Timing

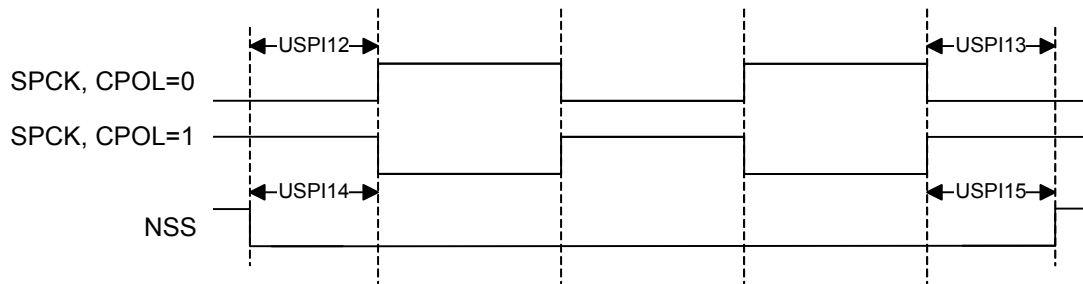

Table 7-40. USART in SPI mode Timing, Slave Mode⁽¹⁾

Symbol	Parameter	Conditions	Min	Max	Units
USPI6	SPCK falling to MISO delay	V _{VDDIO} from 3.0V to 3.6V, maximum external capacitor = 40pF		37.3	ns
USPI7	MOSI setup time before SPCK rises		$2.6 + t_{SAMPLE}^{(2)} + t_{CLK_USART}$		
USPI8	MOSI hold time after SPCK rises		0		
USPI9	SPCK rising to MISO delay			37.0	
USPI10	MOSI setup time before SPCK falls		$2.6 + t_{SAMPLE}^{(2)} + t_{CLK_USART}$		
USPI11	MOSI hold time after SPCK falls		0		
USPI12	NSS setup time before SPCK rises		27.2		
USPI13	NSS hold time after SPCK falls		0		
USPI14	NSS setup time before SPCK falls		27.2		
USPI15	NSS hold time after SPCK rises		0		

Notes: 1. These values are based on simulation and characterization of other AVR microcontrollers manufactured in the same process technology. These values are not covered by test limits in production.

2. Where: $t_{SAMPLE} = t_{SPCK} - \left(\frac{t_{SPCK}}{2 \times t_{CLK_USART}} \right) + \frac{1}{2} \times t_{CLK_USART}$

Maximum SPI Frequency, Slave Input Mode

The maximum SPI slave input frequency is given by the following formula:

$$f_{SPCKMAX} = \text{MIN}\left(\frac{f_{CLKSPI} \times 2}{9}, \frac{1}{SPI_{In}}\right)$$

Where SPI_{In} is the MOSI setup and hold time, USPI7 + USPI8 or USPI10 + USPI11 depending on CPOL and NCPHA. f_{CLKSPI} is the maximum frequency of the CLK_SPI. Refer to the SPI chapter for a description of this clock.

Maximum SPI Frequency, Slave Output Mode

The maximum SPI slave output frequency is given by the following formula:

$$f_{SPCKMAX} = \text{MIN}\left(\frac{f_{CLKSPI} \times 2}{9}, f_{PINMAX} \frac{1}{SPI_{In} + t_{SETUP}}\right)$$

Where SPI_{In} is the MISO delay, USPI6 or USPI9 depending on CPOL and NCPHA. T_{SETUP} is the SPI master setup time. Please refer to the SPI master datasheet for T_{SETUP} . f_{CLKSPI} is the maximum frequency of the CLK_SPI. Refer to the SPI chapter for a description of this clock. f_{PINMAX} is the maximum frequency of the SPI pins. Please refer to the I/O Pin Characteristics section for the maximum frequency of the pins.

7.9.4 SPI Timing

7.9.4.1 Master mode

Figure 7-13. SPI Master Mode with (CPOL= NCPHA= 0) or (CPOL= NCPHA= 1)

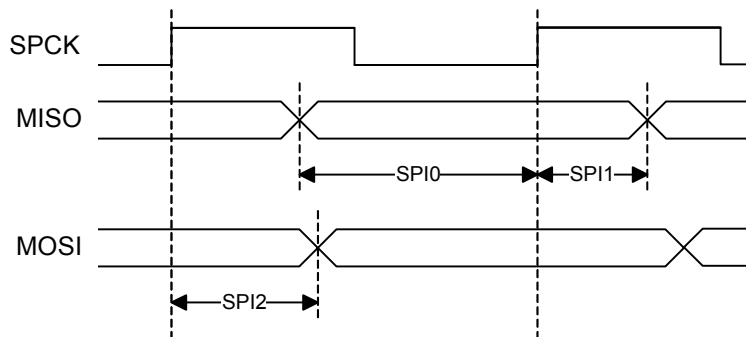

Figure 7-14. SPI Master Mode with (CPOL= 0 and NCPHA= 1) or (CPOL= 1 and NCPHA= 0)

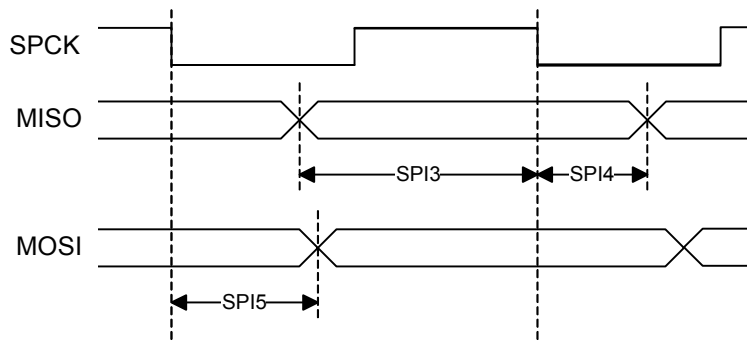

Table 7-41. SPI Timing, Master Mode⁽¹⁾

Symbol	Parameter	Conditions	Min	Max	Units
SPI0	MISO setup time before SPCK rises	V _{VDDIO} from 3.0V to 3.6V, maximum external capacitor = 40pF	33.4 + (t _{CLK_SPI})/2		ns
SPI1	MISO hold time after SPCK rises		0		
SPI2	SPCK rising to MOSI delay			7.1	
SPI3	MISO setup time before SPCK falls		29.2 + (t _{CLK_SPI})/2		
SPI4	MISO hold time after SPCK falls		0		
SPI5	SPCK falling to MOSI delay			8.63	

Note: 1. These values are based on simulation and characterization of other AVR microcontrollers manufactured in the same process technology. These values are not covered by test limits in production.

Maximum SPI Frequency, Master Output

The maximum SPI master output frequency is given by the following formula:

$$f_{SPCKMAX} = \text{MIN}(f_{PINMAX}, \frac{1}{SPI_n})$$

Where SPI_n is the MOSI delay, SPI2 or SPI5 depending on CPOL and NCPHA. f_{PINMAX} is the maximum frequency of the SPI pins. Please refer to the I/O Pin Characteristics section for the maximum frequency of the pins.

Maximum SPI Frequency, Master Input

The maximum SPI master input frequency is given by the following formula:

$$f_{SPCKMAX} = \frac{1}{SPI_n + t_{VALID}}$$

Where SPI_n is the MISO setup and hold time, SPI0 + SPI1 or SPI3 + SPI4 depending on CPOL and NCPHA. t_{VALID} is the SPI slave response time. Please refer to the SPI slave datasheet for t_{VALID} .

7.9.4.2 Slave mode

Figure 7-15. SPI Slave Mode with (CPOL= 0 and NCPHA= 1) or (CPOL= 1 and NCPHA= 0)

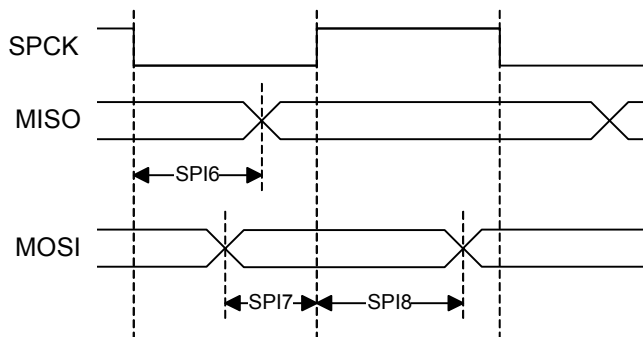

Figure 7-16. SPI Slave Mode with (CPOL= NCPHA= 0) or (CPOL= NCPHA= 1)

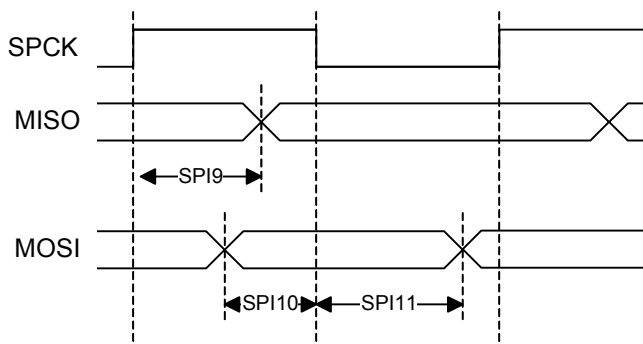

Figure 7-17. SPI Slave Mode, NPCS Timing

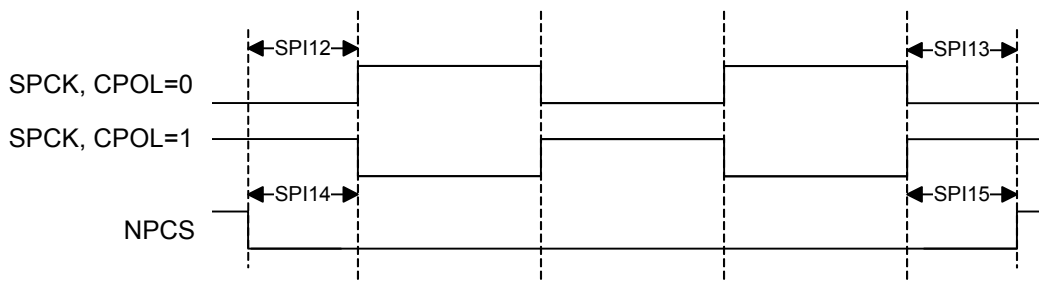

Table 7-42. SPI Timing, Slave Mode⁽¹⁾

Symbol	Parameter	Conditions	Min	Max	Units
SPI6	SPCK falling to MISO delay	V _{VDDIO} from 3.0V to 3.6V, maximum external capacitor = 40pF		29.4	ns
SPI7	MOSI setup time before SPCK rises		0		
SPI8	MOSI hold time after SPCK rises		6.0		
SPI9	SPCK rising to MISO delay			29.0	
SPI10	MOSI setup time before SPCK falls		0		
SPI11	MOSI hold time after SPCK falls		5.5		
SPI12	NPCS setup time before SPCK rises		3.4		
SPI13	NPCS hold time after SPCK falls		1.1		
SPI14	NPCS setup time before SPCK falls		3.3		
SPI15	NPCS hold time after SPCK rises		0.7		

Note: 1. These values are based on simulation and characterization of other AVR microcontrollers manufactured in the same process technology. These values are not covered by test limits in production.

Maximum SPI Frequency, Slave Input Mode

The maximum SPI slave input frequency is given by the following formula:

$$f_{SPCKMAX} = MIN(f_{CLKSPI}, \frac{1}{SPI_{In}})$$

Where *SPI_{In}* is the MOSI setup and hold time, SPI7 + SPI8 or SPI10 + SPI11 depending on CPOL and NCPHA. *f_{CLKSPI}* is the maximum frequency of the CLK_SPI. Refer to the SPI chapter for a description of this clock.

Maximum SPI Frequency, Slave Output Mode

The maximum SPI slave output frequency is given by the following formula:

$$f_{SPCKMAX} = MIN(f_{PINMAX}, \frac{1}{SPI_{In} + t_{SETUP}})$$

Where *SPI_{In}* is the MISO delay, SPI6 or SPI9 depending on CPOL and NCPHA. *t_{SETUP}* is the SPI master setup time. Please refer to the SPI master datasheet for *t_{SETUP}*. *f_{PINMAX}* is the maximum frequency of the SPI pins. Please refer to the I/O Pin Characteristics section for the maximum frequency of the pins.

7.9.5 TWIM/TWIS Timing

Figure 7-43 shows the TWI-bus timing requirements and the compliance of the device with them. Some of these requirements (*t_r* and *t_f*) are met by the device without requiring user intervention. Compliance with the other requirements (*t_{HD-STA}*, *t_{SU-STA}*, *t_{SU-STO}*, *t_{HD-DAT}*, *t_{SU-DAT-TWI}*, *t_{LOW-TWI}*, *t_{HIGH}*, and *f_{TWCK}*) requires user intervention through appropriate programming of the relevant



TWIM and TWIS user interface registers. Please refer to the TWIM and TWIS sections for more information.

Table 7-43. TWI-Bus Timing Requirements

Symbol	Parameter	Mode	Minimum		Maximum		Unit
			Requirement	Device	Requirement	Device	
t _r	TWCK and TWD rise time	Standard ⁽¹⁾	-		1000		ns
		Fast ⁽¹⁾	20 + 0.1C _b		300		
t _f	TWCK and TWD fall time	Standard	-		300		ns
		Fast	20 + 0.1C _b		300		
t _{HD-STA}	(Repeated) START hold time	Standard	4	t _{clkpb}	-		μs
		Fast	0.6				
t _{SU-STA}	(Repeated) START set-up time	Standard	4.7	t _{clkpb}	-		μs
		Fast	0.6				
t _{SU-STO}	STOP set-up time	Standard	4.0	4t _{clkpb}	-		μs
		Fast	0.6				
t _{HD-DAT}	Data hold time	Standard	0.3 ⁽²⁾	2t _{clkpb}	3.45 ⁽⁰⁾	15t _{prescaled} + t _{clkpb}	μs
		Fast			0.9 ⁽⁰⁾		
t _{SU-DAT-TWI}	Data set-up time	Standard	250	2t _{clkpb}	-		ns
		Fast	100				
t _{SU-DAT}		-	-	t _{clkpb}	-		-
t _{LOW-TWI}	TWCK LOW period	Standard	4.7	4t _{clkpb}	-		μs
		Fast	1.3				
t _{LOW}		-	-	t _{clkpb}	-		-
t _{HIGH}	TWCK HIGH period	Standard	4.0	8t _{clkpb}	-		μs
		Fast	0.6				
f _{TWCK}	TWCK frequency	Standard	-		100	1 / 12t _{clkpb}	kHz
		Fast			400		

- Notes: 1. Standard mode: f_{TWCK} ≤ 100 kHz ; fast mode: f_{TWCK} > 100 kHz .
 2. A device must internally provide a hold time of at least 300 ns for TWD with reference to the falling edge of TWCK.

Notations:

C_b = total capacitance of one bus line in pF

t_{clkpb} = period of TWI peripheral bus clock

t_{prescaled} = period of TWI internal prescaled clock (see chapters on TWIM and TWIS)

The maximum t_{HD;DAT} has only to be met if the device does not stretch the LOW period (t_{LOW-TWI}) of TWCK.

7.9.6 JTAG Timing

Figure 7-18. JTAG Interface Signals

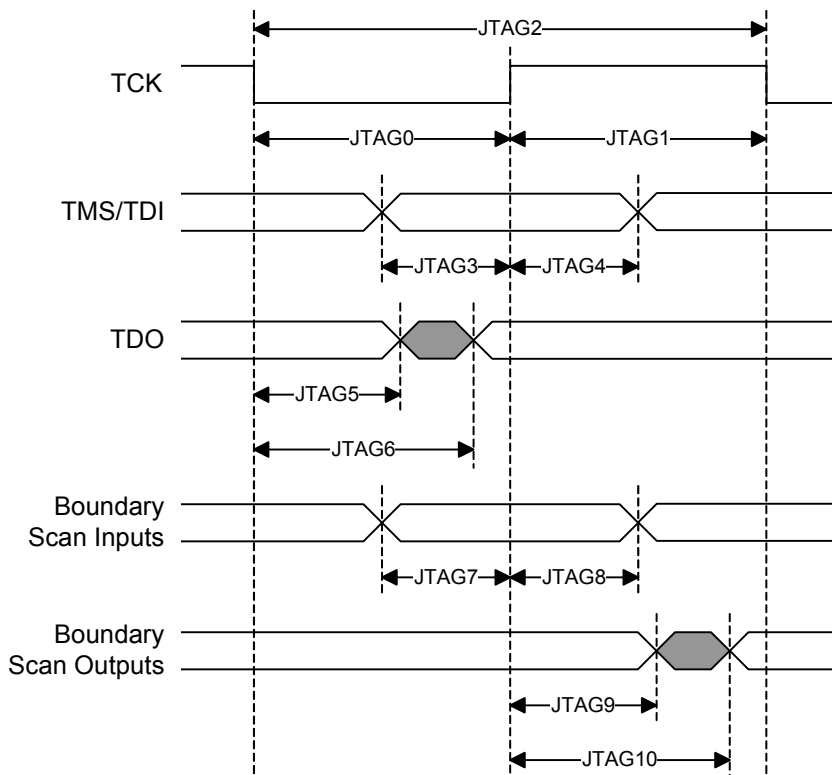

Table 7-44. JTAG Timings⁽¹⁾

Symbol	Parameter	Conditions	Min	Max	Units
JTAG0	TCK Low Half-period	V _{VDDIO} from 3.0V to 3.6V, maximum external capacitor = 40pF	21.8		ns
JTAG1	TCK High Half-period		8.6		
JTAG2	TCK Period		30.3		
JTAG3	TDI, TMS Setup before TCK High		2.0		
JTAG4	TDI, TMS Hold after TCK High		2.3		
JTAG5	TDO Hold Time		9.5		
JTAG6	TCK Low to TDO Valid			21.8	
JTAG7	Boundary Scan Inputs Setup Time		0.6		
JTAG8	Boundary Scan Inputs Hold Time		6.9		
JTAG9	Boundary Scan Outputs Hold Time		9.3		
JTAG10	TCK to Boundary Scan Outputs Valid			32.2	

Note: 1. These values are based on simulation and characterization of other AVR microcontrollers manufactured in the same process technology. These values are not covered by test limits in production.

8. Mechanical Characteristics

8.1 Thermal Considerations

8.1.1 Thermal Data

Table 8-1 summarizes the thermal resistance data depending on the package.

Table 8-1. Thermal Resistance Data

Symbol	Parameter	Condition	Package	Typ	Unit
θ_{JA}	Junction-to-ambient thermal resistance	Still Air	TQFP48	54.4	°C/W
θ_{JC}	Junction-to-case thermal resistance		TQFP48	15.7	
θ_{JA}	Junction-to-ambient thermal resistance	Still Air	QFN48	26.0	°C/W
θ_{JC}	Junction-to-case thermal resistance		QFN48	1.6	
θ_{JA}	Junction-to-ambient thermal resistance	Still Air	TLLGA48	25.4	°C/W
θ_{JC}	Junction-to-case thermal resistance		TLLGA48	12.7	

8.1.2 Junction Temperature

The average chip-junction temperature, T_J , in °C can be obtained from the following:

1. $T_J = T_A + (P_D \times \theta_{JA})$
2. $T_J = T_A + (P_D \times (\theta_{HEATSINK} + \theta_{JC}))$

where:

- θ_{JA} = package thermal resistance, Junction-to-ambient (°C/W), provided in [Table 8-1](#).
- θ_{JC} = package thermal resistance, Junction-to-case thermal resistance (°C/W), provided in [Table 8-1](#).
- $\theta_{HEAT\ SINK}$ = cooling device thermal resistance (°C/W), provided in the device datasheet.
- P_D = device power consumption (W) estimated from data provided in [Section 7.4 on page 42](#).
- T_A = ambient temperature (°C).

From the first equation, the user can derive the estimated lifetime of the chip and decide if a cooling device is necessary or not. If a cooling device is to be fitted on the chip, the second equation should be used to compute the resulting average chip-junction temperature T_J in °C.

8.2 Package Drawings

Figure 8-1. TQFP-48 Package Drawing

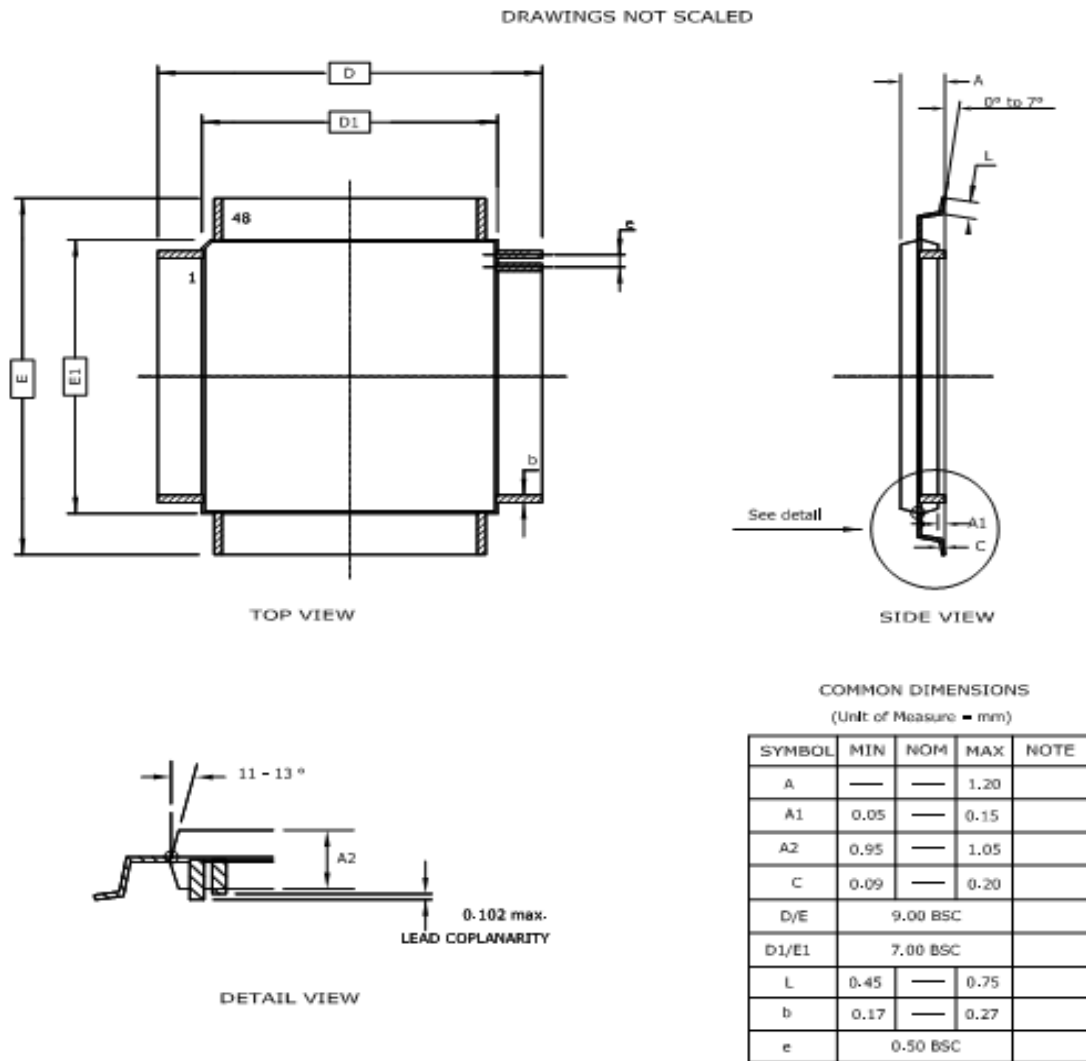

- Notes :
1. This drawing is for general information only. Refer to JEDEC Drawing MS-026, Variation ABC.
 2. Dimensions D1 and E1 do not include mold protrusion. Allowable protrusion is 0.25mm per side. Dimensions D1 and E1 are maximum plastic body size dimensions including mold mismatch.
 3. Lead coplanarity is 0.10mm maximum.

10/04/2011

Table 8-2. Device and Package Maximum Weight

140	mg
-----	----

Table 8-3. Package Characteristics

Moisture Sensitivity Level	MSL3
----------------------------	------

Table 8-4. Package Reference

JEDEC Drawing Reference	MS-026
JESD97 Classification	E3

Figure 8-2. QFN-48 Package Drawing

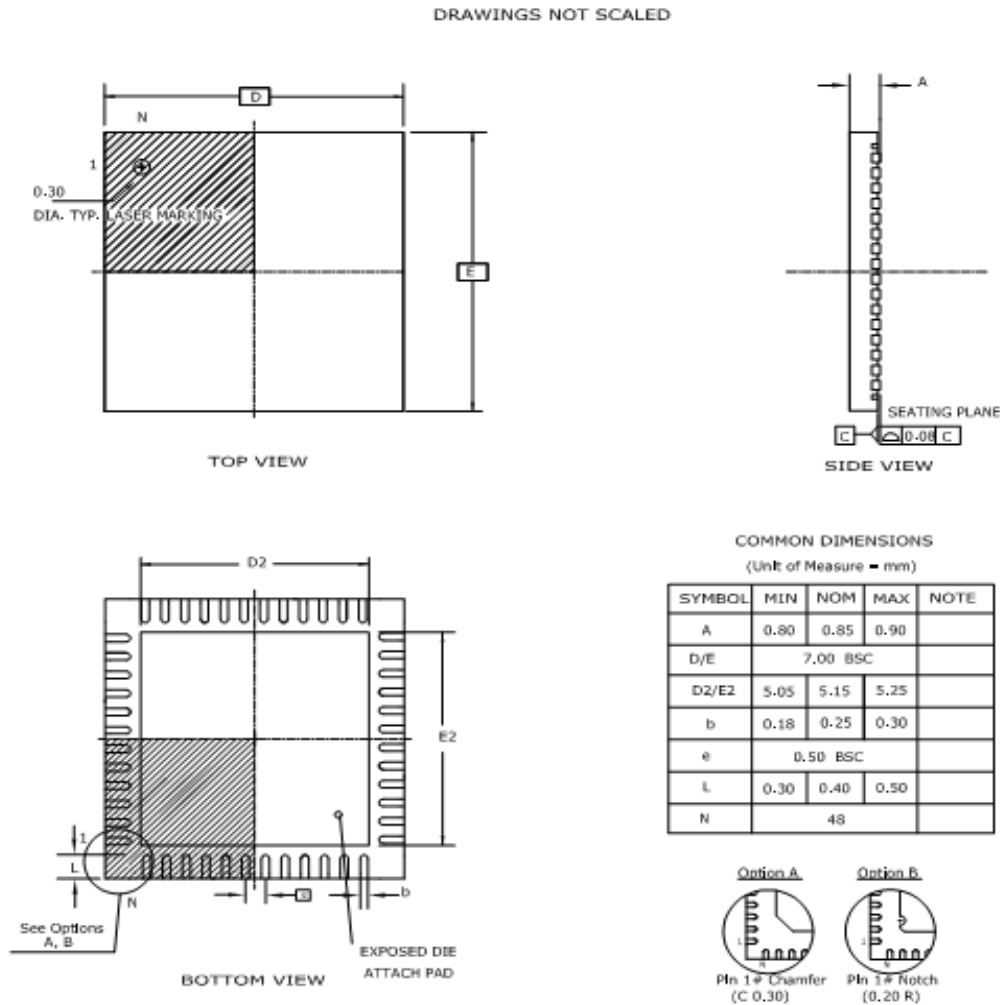

Notes : 1. This drawing is for general information only. Refer to JEDEC Drawing MO-220, Variation VKKD-4, for proper dimensions, tolerances, datums, etc.
 2. Dimension b applies to metalized terminal and is measured between 0.15mm and 0.30mm from the terminal tip.
 If the terminal has the optical radius on the other end of the terminal, the dimension should not be measured in that radius area.

07/27/2011

Note: The exposed pad is not connected to anything internally, but should be soldered to ground to increase board level reliability.

Table 8-5. Device and Package Maximum Weight

140	mg
-----	----

Table 8-6. Package Characteristics

Moisture Sensitivity Level	MSL3
----------------------------	------

Table 8-7. Package Reference

JEDEC Drawing Reference	M0-220
JESD97 Classification	E3

Figure 8-3. TLLGA-48 Package Drawing

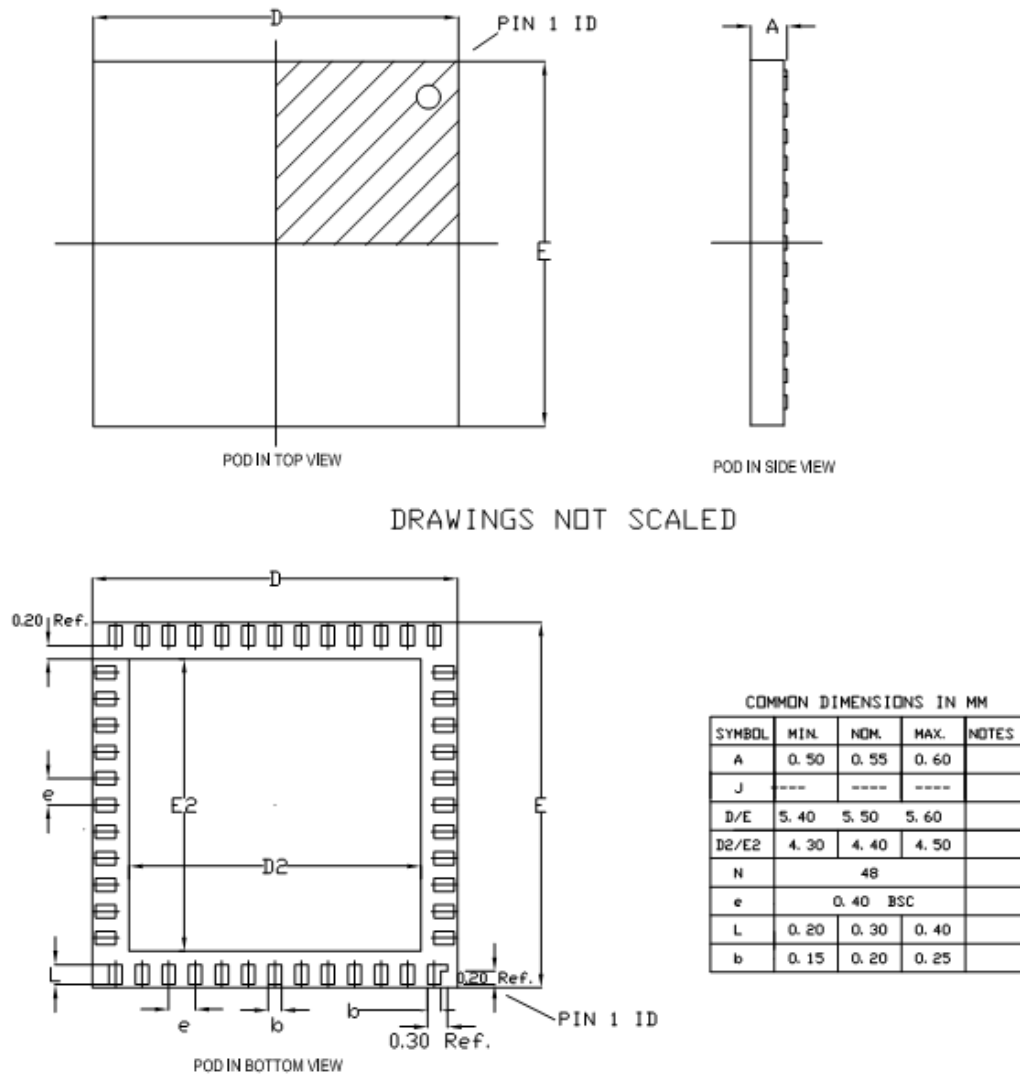

NOT RECOMMENDED TO MOUNT ON ANY FLEX OR FILM PCB OR MCM DEVICE WHICH REQUIRES SECOND MOLD ABOVE THIS PACKAGE

19/05/08

Table 8-8. Device and Package Maximum Weight

39.3	mg
------	----

Table 8-9. Package Characteristics

Moisture Sensitivity Level	MSL3
----------------------------	------

Table 8-10. Package Reference

JEDEC Drawing Reference	N/A
JESD97 Classification	E4

8.3 Soldering Profile

Table 8-11 gives the recommended soldering profile from J-STD-20.

Table 8-11. Soldering Profile

Profile Feature	Green Package
Average Ramp-up Rate (217°C to Peak)	3°C/s max
Preheat Temperature 175°C ±25°C	150-200°C
Time Maintained Above 217°C	60-150 s
Time within 5°C of Actual Peak Temperature	30 s
Peak Temperature Range	260°C
Ramp-down Rate	6°C/s max
Time 25°C to Peak Temperature	8 minutes max

A maximum of three reflow passes is allowed per component.

9. Ordering Information

Table 9-1. Ordering Information

Device	Ordering Code	Carrier Type	Package	Package Type	Temperature Operating Range	
AT32UC3L0256	AT32UC3L0256-AUTES	ES	TQFP 48	JESD97 Classification E3	Industrial (-40°C to 85°C)	
	AT32UC3L0256-AUT	Tray				
	AT32UC3L0256-AUR	Tape & Reel				
	AT32UC3L0256-ZAUTES	ES	QFN 48			
	AT32UC3L0256-ZAUT	Tray				
	AT32UC3L0256-ZAUR	Tape & Reel				
	AT32UC3L0256-D3HES	ES	TLLGA 48			JESD97 Classification E4
	AT32UC3L0256-D3HT	Tray				
	AT32UC3L0256-D3HR	Tape & Reel				
AT32UC3L0128	AT32UC3L0128-AUT	Tray	TQFP 48	JESD97 Classification E3		
	AT32UC3L0128-AUR	Tape & Reel				
	AT32UC3L0128-ZAUT	Tray	QFN 48			
	AT32UC3L0128-ZAUR	Tape & Reel				
	AT32UC3L0128-D3HT	Tray	TLLGA 48		JESD97 Classification E4	
	AT32UC3L0128-D3HR	Tape & Reel				

10. Errata

10.1 Rev. C

10.1.1 SCIF

1. The RC32K output on PA20 is not always permanently disabled

The RC32K output on PA20 may sometimes re-appear.

Fix/Workaround

Before using RC32K for other purposes, the following procedure has to be followed in order to properly disable it:

- Run the CPU on RCSYS
- Disable the output to PA20 by writing a zero to PM.PPCR.RC32OUT
- Enable RC32K by writing a one to SCIF.RC32KCR.EN, and wait for this bit to be read as one
- Disable RC32K by writing a zero to SCIF.RC32KCR.EN, and wait for this bit to be read as zero.

2. PLLCOUNT value larger than zero can cause PLEN glitch

Initializing the PLLCOUNT with a value greater than zero creates a glitch on the PLEN signal during asynchronous wake up.

Fix/Workaround

The lock-masking mechanism for the PLL should not be used.

The PLLCOUNT field of the PLL Control Register should always be written to zero.

3. Writing 0x5A5A5A5A to the SCIF memory range will enable the SCIF UNLOCK feature

The SCIF UNLOCK feature will be enabled if the value 0x5A5A5A5A is written to any location in the SCIF memory range.

Fix/Workaround

None.

10.1.2 SPI

1. SPI data transfer hangs with CSR0.CSAAT==1 and MR.MODFDIS==0

When CSR0.CSAAT==1 and mode fault detection is enabled (MR.MODFDIS==0), the SPI module will not start a data transfer.

Fix/Workaround

Disable mode fault detection by writing a one to MR.MODFDIS.

2. Disabling SPI has no effect on the SR.TDRE bit

Disabling SPI has no effect on the SR.TDRE bit whereas the write data command is filtered when SPI is disabled. Writing to TDR when SPI is disabled will not clear SR.TDRE. If SPI is disabled during a PDCA transfer, the PDCA will continue to write data to TDR until its buffer is empty, and this data will be lost.

Fix/Workaround

Disable the PDCA, add two NOPs, and disable the SPI. To continue the transfer, enable the SPI and PDCA.

3. SPI disable does not work in SLAVE mode

SPI disable does not work in SLAVE mode.

Fix/Workaround

Read the last received data, then perform a software reset by writing a one to the Software Reset bit in the Control Register (CR.SWRST).

4. **SPI bad serial clock generation on 2nd chip_select when SCBR=1, CPOL=1, and NCPHA=0**
 When multiple chip selects (CS) are in use, if one of the baudrates equal 1 while one (CSRn.SCBR=1) of the others do not equal 1, and CSRn.CPOL=1 and CSRn.NCPHA=0, then an additional pulse will be generated on SCK.
Fix/Workaround
 When multiple CS are in use, if one of the baudrates equals 1, the others must also equal 1 if CSRn.CPOL=1 and CSRn.NCPHA=0.

5. **SPI mode fault detection enable causes incorrect behavior**
 When mode fault detection is enabled (MR.MODFDIS==0), the SPI module may not operate properly.
Fix/Workaround
 Always disable mode fault detection before using the SPI by writing a one to MR.MODFDIS.

6. **SPI RDR.PCS is not correct**
 The PCS (Peripheral Chip Select) field in the SPI RDR (Receive Data Register) does not correctly indicate the value on the NPCS pins at the end of a transfer.
Fix/Workaround
 Do not use the PCS field of the SPI RDR.

10.1.3 TWI

1. **SMBALERT bit may be set after reset**
 The SMBus Alert (SMBALERT) bit in the Status Register (SR) might be erroneously set after system reset.
Fix/Workaround
 After system reset, clear the SR.SMBALERT bit before commencing any TWI transfer.

2. **Clearing the NAK bit before the BTF bit is set locks up the TWI bus**
 When the TWIS is in transmit mode, clearing the NAK Received (NAK) bit of the Status Register (SR) before the end of the Acknowledge/Not Acknowledge cycle will cause the TWIS to attempt to continue transmitting data, thus locking up the bus.
Fix/Workaround
 Clear SR.NAK only after the Byte Transfer Finished (BTF) bit of the same register has been set.

10.1.4 TC

1. **Channel chaining skips first pulse for upper channel**
 When chaining two channels using the Block Mode Register, the first pulse of the clock between the channels is skipped.
Fix/Workaround
 Configure the lower channel with RA = 0x1 and RC = 0x2 to produce a dummy clock cycle for the upper channel. After the dummy cycle has been generated, indicated by the SR.CPCS bit, reconfigure the RA and RC registers for the lower channel with the real values.

10.1.5 CAT

1. **CAT QMatrix sense capacitors discharged prematurely**
 At the end of a QMatrix burst charging sequence that uses different burst count values for different Y lines, the Y lines may be incorrectly grounded for up to n-1 periods of the periph-

eral bus clock, where n is the ratio of the PB clock frequency to the GCLK_CAT frequency. This results in premature loss of charge from the sense capacitors and thus increased variability of the acquired count values.

Fix/Workaround

Enable the 1kOhm drive resistors on all implemented QMatrix Y lines (CSA 1, 3, 5, 7, 9, 11, 13, and/or 15) by writing ones to the corresponding odd bits of the CSARES register.

2. Autonomous CAT acquisition must be longer than AST source clock period

When using the AST to trigger CAT autonomous touch acquisition in sleep modes where the CAT bus clock is turned off, the CAT will start several acquisitions if the period of the AST source clock is larger than one CAT acquisition. One AST clock period after the AST trigger, the CAT clock will automatically stop and the CAT acquisition can be stopped prematurely, ruining the result.

Fix/Workaround

Always ensure that the ATCFG1.max field is set so that the duration of the autonomous touch acquisition is greater than one clock period of the AST source clock.

10.1.6 aWire

1. aWire MEMORY_SPEED_REQUEST command does not return correct CV

The aWire MEMORY_SPEED_REQUEST command does not return a CV corresponding to the formula in the aWire Debug Interface chapter.

Fix/Workaround

Issue a dummy read to address 0x10000000 before issuing the MEMORY_SPEED_REQUEST command and use this formula instead:

$$f_{sab} = \frac{7f_{aw}}{CV-3}$$

10.2 Rev. B

10.2.1 SCIF

1. The RC32K output on PA20 is not always permanently disabled

The RC32K output on PA20 may sometimes re-appear.

Fix/Workaround

Before using RC32K for other purposes, the following procedure has to be followed in order to properly disable it:

- Run the CPU on RCSYS
- Disable the output to PA20 by writing a zero to PM.PPCR.RC32OUT
- Enable RC32K by writing a one to SCIF.RC32KCR.EN, and wait for this bit to be read as one
- Disable RC32K by writing a zero to SCIF.RC32KCR.EN, and wait for this bit to be read as zero.

2. PLLCOUNT value larger than zero can cause PLEN glitch

Initializing the PLLCOUNT with a value greater than zero creates a glitch on the PLEN signal during asynchronous wake up.

Fix/Workaround

The lock-masking mechanism for the PLL should not be used.

The PLLCOUNT field of the PLL Control Register should always be written to zero.

3. Writing 0x5A5A5A5A to the SCIF memory range will enable the SCIF UNLOCK feature

The SCIF UNLOCK feature will be enabled if the value 0x5A5A5A5A is written to any location in the SCIF memory range.

Fix/Workaround

None.

10.2.2 WDT

1. WDT Control Register does not have synchronization feedback

When writing to the Timeout Prescale Select (PSEL), Time Ban Prescale Select (TBAN), Enable (EN), or WDT Mode (MODE) fields of the WDT Control Register (CTRL), a synchronizer is started to propagate the values to the WDT clock domain. This synchronization takes a finite amount of time, but only the status of the synchronization of the EN bit is reflected back to the user. Writing to the synchronized fields during synchronization can lead to undefined behavior.

Fix/Workaround

-When writing to the affected fields, the user must ensure a wait corresponding to 2 clock cycles of both the WDT peripheral bus clock and the selected WDT clock source.

-When doing writes that changes the EN bit, the EN bit can be read back until it reflects the written value.

10.2.3 SPI

1. SPI data transfer hangs with CSR0.CSAAT==1 and MR.MODFDIS==0

When CSR0.CSAAT==1 and mode fault detection is enabled (MR.MODFDIS==0), the SPI module will not start a data transfer.

Fix/Workaround

Disable mode fault detection by writing a one to MR.MODFDIS.

2. Disabling SPI has no effect on the SR.TDRE bit

Disabling SPI has no effect on the SR.TDRE bit whereas the write data command is filtered when SPI is disabled. Writing to TDR when SPI is disabled will not clear SR.TDRE. If SPI is disabled during a PDCA transfer, the PDCA will continue to write data to TDR until its buffer is empty, and this data will be lost.

Fix/Workaround

Disable the PDCA, add two NOPs, and disable the SPI. To continue the transfer, enable the SPI and PDCA.

3. SPI disable does not work in SLAVE mode

SPI disable does not work in SLAVE mode.

Fix/Workaround

Read the last received data, then perform a software reset by writing a one to the Software Reset bit in the Control Register (CR.SWRST).

4. SPI bad serial clock generation on 2nd chip_select when SCBR=1, CPOL=1, and NCPHA=0

When multiple chip selects (CS) are in use, if one of the baudrates equal 1 while one (CSRn.SCBR=1) of the others do not equal 1, and CSRn.CPOL=1 and CSRn.NCPHA=0, then an additional pulse will be generated on SCK.

Fix/Workaround

When multiple CS are in use, if one of the baudrates equals 1, the others must also equal 1 if CSRn.CPOL=1 and CSRn.NCPHA=0.

5. SPI mode fault detection enable causes incorrect behavior

When mode fault detection is enabled (MR.MODFDIS==0), the SPI module may not operate

properly.

Fix/Workaround

Always disable mode fault detection before using the SPI by writing a one to MR.MODFDIS.

6. SPI RDR.PCS is not correct

The PCS (Peripheral Chip Select) field in the SPI RDR (Receive Data Register) does not correctly indicate the value on the NPCS pins at the end of a transfer.

Fix/Workaround

Do not use the PCS field of the SPI RDR.

10.2.4 TWI

1. TWIS may not wake the device from sleep mode

If the CPU is put to a sleep mode (except Idle and Frozen) directly after a TWI Start condition, the CPU may not wake upon a TWIS address match. The request is NACKed.

Fix/Workaround

When using the TWI address match to wake the device from sleep, do not switch to sleep modes deeper than Frozen. Another solution is to enable asynchronous EIC wake on the TWIS clock (TWCK) or TWIS data (TWD) pins, in order to wake the system up on bus events.

2. SMBALERT bit may be set after reset

The SMBus Alert (SMBALERT) bit in the Status Register (SR) might be erroneously set after system reset.

Fix/Workaround

After system reset, clear the SR.SMBALERT bit before commencing any TWI transfer.

3. Clearing the NAK bit before the BTF bit is set locks up the TWI bus

When the TWIS is in transmit mode, clearing the NAK Received (NAK) bit of the Status Register (SR) before the end of the Acknowledge/Not Acknowledge cycle will cause the TWIS to attempt to continue transmitting data, thus locking up the bus.

Fix/Workaround

Clear SR.NAK only after the Byte Transfer Finished (BTF) bit of the same register has been set.

10.2.5 PWMA

1. The SR.READY bit cannot be cleared by writing to SCR.READY

The Ready bit in the Status Register will not be cleared when writing a one to the corresponding bit in the Status Clear register. The Ready bit will be cleared when the Busy bit is set.

Fix/Workaround

Disable the Ready interrupt in the interrupt handler when receiving the interrupt. When an operation that triggers the Busy/Ready bit is started, wait until the ready bit is low in the Status Register before enabling the interrupt.

10.2.6 TC

1. Channel chaining skips first pulse for upper channel

When chaining two channels using the Block Mode Register, the first pulse of the clock between the channels is skipped.

Fix/Workaround

Configure the lower channel with RA = 0x1 and RC = 0x2 to produce a dummy clock cycle for the upper channel. After the dummy cycle has been generated, indicated by the SR.CPCS bit, reconfigure the RA and RC registers for the lower channel with the real values.

10.2.7 CAT

1. CAT QMatrix sense capacitors discharged prematurely

At the end of a QMatrix burst charging sequence that uses different burst count values for different Y lines, the Y lines may be incorrectly grounded for up to n-1 periods of the peripheral bus clock, where n is the ratio of the PB clock frequency to the GCLK_CAT frequency. This results in premature loss of charge from the sense capacitors and thus increased variability of the acquired count values.

Fix/Workaround

Enable the 1kOhm drive resistors on all implemented QMatrix Y lines (CSA 1, 3, 5, 7, 9, 11, 13, and/or 15) by writing ones to the corresponding odd bits of the CSARES register.

2. Autonomous CAT acquisition must be longer than AST source clock period

When using the AST to trigger CAT autonomous touch acquisition in sleep modes where the CAT bus clock is turned off, the CAT will start several acquisitions if the period of the AST source clock is larger than one CAT acquisition. One AST clock period after the AST trigger, the CAT clock will automatically stop and the CAT acquisition can be stopped prematurely, ruining the result.

Fix/Workaround

Always ensure that the ATCFG1.max field is set so that the duration of the autonomous touch acquisition is greater than one clock period of the AST source clock.

3. CAT consumes unnecessary power when disabled or when autonomous touch not used

A CAT prescaler controlled by the ATCFG0.DIV field will be active even when the CAT module is disabled or when the autonomous touch feature is not used, thereby causing unnecessary power consumption.

Fix/Workaround

If the CAT module is not used, disable the CLK_CAT clock in the PM module. If the CAT module is used but the autonomous touch feature is not used, the power consumption of the CAT module may be reduced by writing 0xFFFF to the ATCFG0.DIV field.

10.2.8 aWire

1. aWire MEMORY_SPEED_REQUEST command does not return correct CV

The aWire MEMORY_SPEED_REQUEST command does not return a CV corresponding to the formula in the aWire Debug Interface chapter.

Fix/Workaround

Issue a dummy read to address 0x10000000 before issuing the MEMORY_SPEED_REQUEST command and use this formula instead:

$$f_{sab} = \frac{7f_{aw}}{CV-3}$$

10.3 Rev. A

10.3.1 Device

1. **JTAGID is wrong**
The JTAGID is 0x021DF03F.
Fix/Workaround
None.

10.3.2 FLASHCDW

1. **General-purpose fuse programming does not work**
The general-purpose fuses cannot be programmed and are stuck at 1. Please refer to the Fuse Settings chapter in the FLASHCDW for more information about what functions are affected.
Fix/Workaround
None.
2. **Set Security Bit command does not work**
The Set Security Bit (SSB) command of the FLASHCDW does not work. The device cannot be locked from external JTAG, aWire, or other debug accesses.
Fix/Workaround
None.
3. **Flash programming time is longer than specified**
The flash programming time is now:

Table 10-1. Flash Characteristics

Symbol	Parameter	Conditions	Min	Typ	Max	Unit
T _{FPP}	Page programming time	f _{CLK_HSB} = 50MHz		7.5		ms
T _{FPE}	Page erase time			7.5		
T _{FFP}	Fuse programming time			1		
T _{FEA}	Full chip erase time (EA)			9		
T _{FCE}	JTAG chip erase time (CHIP_ERASE)	f _{CLK_HSB} = 115kHz		250		

Fix/Workaround
None.

10.3.3 Power Manager

1. **Clock Failure Detector (CFD) can be issued while turning off the CFD**
While turning off the CFD, the CFD bit in the Status Register (SR) can be set. This will change the main clock source to RCSYS.
Fix/Workaround
Solution 1: Enable CFD interrupt. If CFD interrupt is issues after turning off the CFD, switch back to original main clock source.
Solution 2: Only turn off the CFD while running the main clock on RCSYS.
2. **Sleepwalking in idle and frozen sleep mode will mask all other PB clocks**

If the CPU is in idle or frozen sleep mode and a module is in a state that triggers sleep walking, all PB clocks will be masked except the PB clock to the sleepwalking module.

Fix/Workaround

Mask all clock requests in the PM.PPCR register before going into idle or frozen mode.

2. Unused PB clocks are running

Three unused PBA clocks are enabled by default and will cause increased active power consumption.

Fix/Workaround

Disable the clocks by writing zeroes to bits [27:25] in the PBA clock mask register.

10.3.4 SCIF

1. The RC32K output on PA20 is not always permanently disabled

The RC32K output on PA20 may sometimes re-appear.

Fix/Workaround

Before using RC32K for other purposes, the following procedure has to be followed in order to properly disable it:

- Run the CPU on RCSYS
- Disable the output to PA20 by writing a zero to PM.PPCR.RC32OUT
- Enable RC32K by writing a one to SCIF.RC32KCR.EN, and wait for this bit to be read as one
- Disable RC32K by writing a zero to SCIF.RC32KCR.EN, and wait for this bit to be read as zero.

2. PLL lock might not clear after disable

Under certain circumstances, the lock signal from the Phase Locked Loop (PLL) oscillator may not go back to zero after the PLL oscillator has been disabled. This can cause the propagation of clock signals with the wrong frequency to parts of the system that use the PLL clock.

Fix/Workaround

PLL must be turned off before entering STOP, DEEPSTOP or STATIC sleep modes. If PLL has been turned off, a delay of 30us must be observed after the PLL has been enabled again before the SCIF.PLL0LOCK bit can be used as a valid indication that the PLL is locked.

3. PLLCOUNT value larger than zero can cause PLEN glitch

Initializing the PLLCOUNT with a value greater than zero creates a glitch on the PLEN signal during asynchronous wake up.

Fix/Workaround

The lock-masking mechanism for the PLL should not be used.

The PLLCOUNT field of the PLL Control Register should always be written to zero.

4. RCSYS is not calibrated

The RCSYS is not calibrated and will run faster than 115.2kHz. Frequencies around 150kHz can be expected.

Fix/Workaround

If a known clock source is available the RCSYS can be runtime calibrated by using the frequency meter (FREQM) and tuning the RCSYS by writing to the RCCR register in SCIF.

5. Writing 0x5A5A5A5A to the SCIF memory range will enable the SCIF UNLOCK feature

The SCIF UNLOCK feature will be enabled if the value 0x5A5A5A5A is written to any location in the SCIF memory range.

Fix/Workaround

None.

10.3.5 WDT

1. Clearing the Watchdog Timer (WDT) counter in second half of timeout period will issue a Watchdog reset

If the WDT counter is cleared in the second half of the timeout period, the WDT will immediately issue a Watchdog reset.

Fix/Workaround

Use twice as long timeout period as needed and clear the WDT counter within the first half of the timeout period. If the WDT counter is cleared after the first half of the timeout period, you will get a Watchdog reset immediately. If the WDT counter is not cleared at all, the time before the reset will be twice as long as needed.

2. WDT Control Register does not have synchronization feedback

When writing to the Timeout Prescale Select (PSEL), Time Ban Prescale Select (TBAN), Enable (EN), or WDT Mode (MODE) fields of the WDT Control Register (CTRL), a synchronizer is started to propagate the values to the WDT clock domain. This synchronization takes a finite amount of time, but only the status of the synchronization of the EN bit is reflected back to the user. Writing to the synchronized fields during synchronization can lead to undefined behavior.

Fix/Workaround

-When writing to the affected fields, the user must ensure a wait corresponding to 2 clock cycles of both the WDT peripheral bus clock and the selected WDT clock source.

-When doing writes that changes the EN bit, the EN bit can be read back until it reflects the written value.

10.3.6 GPIO

1. Clearing Interrupt flags can mask other interrupts

When clearing interrupt flags in a GPIO port, interrupts on other pins of that port, happening in the same clock cycle will not be registered.

Fix/Workaround

Read the PVR register of the port before and after clearing the interrupt to see if any pin change has happened while clearing the interrupt. If any change occurred in the PVR between the reads, they must be treated as an interrupt.

10.3.7 SPI

1. SPI data transfer hangs with CSR0.CSAAT==1 and MR.MODFDIS==0

When CSR0.CSAAT==1 and mode fault detection is enabled (MR.MODFDIS==0), the SPI module will not start a data transfer.

Fix/Workaround

Disable mode fault detection by writing a one to MR.MODFDIS.

2. Disabling SPI has no effect on the SR.TDRE bit

Disabling SPI has no effect on the SR.TDRE bit whereas the write data command is filtered when SPI is disabled. Writing to TDR when SPI is disabled will not clear SR.TDRE. If SPI is disabled during a PDCA transfer, the PDCA will continue to write data to TDR until its buffer is empty, and this data will be lost.

Fix/Workaround

Disable the PDCA, add two NOPs, and disable the SPI. To continue the transfer, enable the SPI and PDCA.

3. **SPI disable does not work in SLAVE mode**
 SPI disable does not work in SLAVE mode.
Fix/Workaround
 Read the last received data, then perform a software reset by writing a one to the Software Reset bit in the Control Register (CR.SWRST).
4. **SPI bad serial clock generation on 2nd chip_select when SCBR=1, CPOL=1, and NCPHA=0**
 When multiple chip selects (CS) are in use, if one of the baudrates equal 1 while one (CSRn.SCBR=1) of the others do not equal 1, and CSRn.CPOL=1 and CSRn.NCPHA=0, then an additional pulse will be generated on SCK.
Fix/Workaround
 When multiple CS are in use, if one of the baudrates equals 1, the others must also equal 1 if CSRn.CPOL=1 and CSRn.NCPHA=0.
5. **SPI mode fault detection enable causes incorrect behavior**
 When mode fault detection is enabled (MR.MODFDIS==0), the SPI module may not operate properly.
Fix/Workaround
 Always disable mode fault detection before using the SPI by writing a one to MR.MODFDIS.
6. **SPI RDR.PCS is not correct**
 The PCS (Peripheral Chip Select) field in the SPI RDR (Receive Data Register) does not correctly indicate the value on the NPCS pins at the end of a transfer.
Fix/Workaround
 Do not use the PCS field of the SPI RDR.

10.3.8 TWI

1. **TWIS may not wake the device from sleep mode**
 If the CPU is put to a sleep mode (except Idle and Frozen) directly after a TWI Start condition, the CPU may not wake upon a TWIS address match. The request is NACKed.
Fix/Workaround
 When using the TWI address match to wake the device from sleep, do not switch to sleep modes deeper than Frozen. Another solution is to enable asynchronous EIC wake on the TWIS clock (TWCK) or TWIS data (TWD) pins, in order to wake the system up on bus events.
2. **SMBALERT bit may be set after reset**
 The SMBus Alert (SMBALERT) bit in the Status Register (SR) might be erroneously set after system reset.
Fix/Workaround
 After system reset, clear the SR.SMBALERT bit before commencing any TWI transfer.
3. **Clearing the NAK bit before the BTF bit is set locks up the TWI bus**
 When the TWIS is in transmit mode, clearing the NAK Received (NAK) bit of the Status Register (SR) before the end of the Acknowledge/Not Acknowledge cycle will cause the TWIS to attempt to continue transmitting data, thus locking up the bus.
Fix/Workaround
 Clear SR.NAK only after the Byte Transfer Finished (BTF) bit of the same register has been set.
4. **TWIS stretch on Address match error**

When the TWIS stretches TWCK due to a slave address match, it also holds TWD low for the same duration if it is to be receiving data. When TWIS releases TWCK, it releases TWD at the same time. This can cause a TWI timing violation.

Fix/Workaround

None.

5. TWIM TWALM polarity is wrong

The TWALM signal in the TWIM is active high instead of active low.

Fix/Workaround

Use an external inverter to invert the signal going into the TWIM. When using both TWIM and TWIS on the same pins, the TWALM cannot be used.

10.3.9 PWMA

1. The SR.READY bit cannot be cleared by writing to SCR.READY

The Ready bit in the Status Register will not be cleared when writing a one to the corresponding bit in the Status Clear register. The Ready bit will be cleared when the Busy bit is set.

Fix/Workaround

Disable the Ready interrupt in the interrupt handler when receiving the interrupt. When an operation that triggers the Busy/Ready bit is started, wait until the ready bit is low in the Status Register before enabling the interrupt.

10.3.10 TC

1. Channel chaining skips first pulse for upper channel

When chaining two channels using the Block Mode Register, the first pulse of the clock between the channels is skipped.

Fix/Workaround

Configure the lower channel with RA = 0x1 and RC = 0x2 to produce a dummy clock cycle for the upper channel. After the dummy cycle has been generated, indicated by the SR.CPCS bit, reconfigure the RA and RC registers for the lower channel with the real values.

10.3.11 ADCIFB

1. ADCIFB DMA transfer does not work with divided PBA clock

DMA requests from the ADCIFB will not be performed when the PBA clock is slower than the HSB clock.

Fix/Workaround

Do not use divided PBA clock when the PDCA transfers from the ADCIFB.

10.3.12 CAT

1. CAT QMatrix sense capacitors discharged prematurely

At the end of a QMatrix burst charging sequence that uses different burst count values for different Y lines, the Y lines may be incorrectly grounded for up to n-1 periods of the peripheral bus clock, where n is the ratio of the PB clock frequency to the GCLK_CAT frequency. This results in premature loss of charge from the sense capacitors and thus increased variability of the acquired count values.

Fix/Workaround

Enable the 1kOhm drive resistors on all implemented QMatrix Y lines (CSA 1, 3, 5, 7, 9, 11, 13, and/or 15) by writing ones to the corresponding odd bits of the CSARES register.

2. Autonomous CAT acquisition must be longer than AST source clock period

When using the AST to trigger CAT autonomous touch acquisition in sleep modes where the CAT bus clock is turned off, the CAT will start several acquisitions if the period of the AST source clock is larger than one CAT acquisition. One AST clock period after the AST trigger, the CAT clock will automatically stop and the CAT acquisition can be stopped prematurely, ruining the result.

Fix/Workaround

Always ensure that the ATCFG1.max field is set so that the duration of the autonomous touch acquisition is greater than one clock period of the AST source clock.

3. CAT consumes unnecessary power when disabled or when autonomous touch not used

A CAT prescaler controlled by the ATCFG0.DIV field will be active even when the CAT module is disabled or when the autonomous touch feature is not used, thereby causing unnecessary power consumption.

Fix/Workaround

If the CAT module is not used, disable the CLK_CAT clock in the PM module. If the CAT module is used but the autonomous touch feature is not used, the power consumption of the CAT module may be reduced by writing 0xFFFF to the ATCFG0.DIV field.

4. CAT module does not terminate QTouch burst on detect

The CAT module does not terminate a QTouch burst when the detection voltage is reached on the sense capacitor. This can cause the sense capacitor to be charged more than necessary. Depending on the dielectric absorption characteristics of the capacitor, this can lead to unstable measurements.

Fix/Workaround

Use the minimum possible value for the MAX field in the ATCFG1, TG0CFG1, and TG1CFG1 registers.

10.3.13 aWire

1. aWire MEMORY_SPEED_REQUEST command does not return correct CV

The aWire MEMORY_SPEED_REQUEST command does not return a CV corresponding to the formula in the aWire Debug Interface chapter.

Fix/Workaround

Issue a dummy read to address 0x10000000 before issuing the MEMORY_SPEED_REQUEST command and use this formula instead:

$$f_{sab} = \frac{7f_{aw}}{CV-3}$$

10.3.14 I/O Pins

1. PA05 is not 3.3V tolerant.

PA05 should be grounded on the PCB and left unused if VDDIO is above 1.8V.

Fix/Workaround

None.

2. No pull-up on pins that are not bonded

PB13 to PB27 are not bonded on UC3L0256/128, but has no pull-up and can cause current consumption on VDDIO/VDDIN if left undriven.

Fix/Workaround

Enable pull-ups on PB13 to PB27 by writing 0x0FFFE000 to the PUERS1 register in the GPIO.

3. PA17 has low ESD tolerance

PA17 only tolerates 500V ESD pulses (Human Body Model).

Fix/Workaround

Care must be taken during manufacturing and PCB design.

11. Datasheet Revision History

Please note that the referring page numbers in this section are referred to this document. The referring revision in this section are referring to the document revision.

11.1 Rev. B – 01/2012

1. Description: DFLL frequency is 20 to 150MHz, not 40 to 150MHz.
2. Description: “One touch sensor can be configured to operate autonomously...” replaced by “All touch sensors can be configured to operate autonomously...”.
3. Block Diagram: GCLK_IN is input, not output, and is 2 bits wide (GCLK_IN[1..0]). CAT SMP corrected from I/O to output. SPI NPCS corrected from output to I/O.
4. Package and Pinout: PRND signal removed from Signal Descriptions List table and GPIO Controller Function Multiplexing table.
5. Supply and Startup Considerations: In 1.8V single supply mode figure, the input voltage is 1.62-1.98V, not 1.98-3.6V. “On system start-up, the DFLL is disabled” is replaced by “On system start-up, all high-speed clocks are disabled”.
6. ADCIFB: PRND signal removed from block diagram.
7. Electrical Characteristics: Added PLL source clock in the Clock Frequencies table in the Maximum Clock Frequencies section. Removed 64-pin package information from I/O Pin Characteristics tables and Digital Clock Characteristics table.
8. Electrical Characteristics: Removed USB Transceiver Characteristics, as the device contains no USB.
9. Mechanical Characteristics: Added notes to package drawings.
10. Summary: Removed Programming and Debugging chapter, added Processor and Architecture chapter.
11. Datasheet Revision History: Corrected release date for datasheet rev. A; the correct date is 12/2011.

11.2 Rev. A – 12/2011

1. Initial revision.

Table of Contents

	Features	1
1	Description	3
2	Overview	5
	2.1 Block Diagram	5
	2.2 Configuration Summary	6
3	Package and Pinout	7
	3.1 Package	7
	3.2 Peripheral Multiplexing on I/O Lines	8
	3.3 Signal Descriptions	13
	3.4 I/O Line Considerations	16
4	Processor and Architecture	18
	4.1 Features	18
	4.2 AVR32 Architecture	18
	4.3 The AVR32UC CPU	19
	4.4 Programming Model	23
	4.5 Exceptions and Interrupts	27
5	Memories	32
	5.1 Embedded Memories	32
	5.2 Physical Memory Map	32
	5.3 Peripheral Address Map	33
	5.4 CPU Local Bus Mapping	34
6	Supply and Startup Considerations	36
	6.1 Supply Considerations	36
	6.2 Startup Considerations	40
7	Electrical Characteristics	41
	7.1 Absolute Maximum Ratings*	41
	7.2 Supply Characteristics	41
	7.3 Maximum Clock Frequencies	42
	7.4 Power Consumption	42
	7.5 I/O Pin Characteristics	46
	7.6 Oscillator Characteristics	49
	7.7 Flash Characteristics	54

7.8 Analog Characteristics55

7.9 Timing Characteristics64

8 Mechanical Characteristics 74

8.1 Thermal Considerations74

8.2 Package Drawings75

8.3 Soldering Profile78

9 Ordering Information 79

10 Errata 80

10.1 Rev. C80

10.2 Rev. B82

10.3 Rev. A86

11 Datasheet Revision History 93

11.1 Rev. B – 01/201293

11.2 Rev. A – 12/201193

Table of Contents..... i

**Atmel Corporation**

2325 Orchard Parkway
San Jose, CA 95131
USA

Tel: (+1)(408) 441-0311

Fax: (+1)(408) 487-2600

www.atmel.com

Atmel Asia Limited

Unit 1-5 & 16, 19/F
BEA Tower, Millennium City 5
418 Kwun Tong Road
Kwun Tong, Kowloon
HONG KONG

Tel: (+852) 2245-6100

Fax: (+852) 2722-1369

Atmel Munich GmbH

Business Campus
Parkring 4
D-85748 Garching b. Munich
GERMANY

Tel: (+49) 89-31970-0

Fax: (+49) 89-3194621

Atmel Japan

16F, Shin Osaki Kangyo Bldg.
1-6-4 Osaka Shinagawa-ku
Tokyo 104-0032

JAPAN

Tel: (+81) 3-6417-0300

Fax: (+81) 3-6417-0370

© 2012 Atmel Corporation. All rights reserved.

Atmel[®], logo and combinations thereof, AVR[®], picoPower[®], QTouch[®], AKS[®] and others are registered trademarks or trademarks of Atmel Corporation or its subsidiaries. Other terms and product names may be trademarks of others.

Disclaimer: The information in this document is provided in connection with Atmel products. No license, express or implied, by estoppel or otherwise, to any intellectual property right is granted by this document or in connection with the sale of Atmel products. **EXCEPT AS SET FORTH IN THE ATMEL TERMS AND CONDITIONS OF SALES LOCATED ON THE ATMEL WEBSITE, ATMEL ASSUMES NO LIABILITY WHATSOEVER AND DISCLAIMS ANY EXPRESS, IMPLIED OR STATUTORY WARRANTY RELATING TO ITS PRODUCTS INCLUDING, BUT NOT LIMITED TO, THE IMPLIED WARRANTY OF MERCHANTABILITY, FITNESS FOR A PARTICULAR PURPOSE, OR NON-INFRINGEMENT. IN NO EVENT SHALL ATMEL BE LIABLE FOR ANY DIRECT, INDIRECT, CONSEQUENTIAL, PUNITIVE, SPECIAL OR INCIDENTAL DAMAGES (INCLUDING, WITHOUT LIMITATION, DAMAGES FOR LOSS AND PROFITS, BUSINESS INTERRUPTION, OR LOSS OF INFORMATION) ARISING OUT OF THE USE OR INABILITY TO USE THIS DOCUMENT, EVEN IF ATMEL HAS BEEN ADVISED OF THE POSSIBILITY OF SUCH DAMAGES.** Atmel makes no representations or warranties with respect to the accuracy or completeness of the contents of this document and reserves the right to make changes to specifications and product descriptions at any time without notice. Atmel does not make any commitment to update the information contained herein. Unless specifically provided otherwise, Atmel products are not suitable for, and shall not be used in, automotive applications. Atmel products are not intended, authorized, or warranted for use as components in applications intended to support or sustain life.