

ASMT-QWBF-NKLOE

Super 0.5 W Cool White Power PLCC-4
Surface Mount LED Indicator



Data Sheet



Description

The Super 0.5 W Cool White Power PLCC-4 SMT LED is using InGaN chip technology. The package can be driven at high current due to its superior package design. The product is able to dissipate the heat more efficiently compared to the Power PLCC-4 SMT LEDs. These LEDs produce higher light output with better flux performance compared to the Power PLCC-4 SMT LED.

The Super 0.5 W Cool White Power PLCC-4 SMT LEDs are designed for higher reliability, better performance, and operate under a wide range of environmental conditions.

To facilitate easy pick and place assembly, the LEDs are packed in EIA-compliant tape and reel. Every reel is shipped in single intensity and color bin, to provide close uniformity.

Features

- Industry Standard PLCC 4 platform (3.2 x 2.8 x 1.9 mm)
- High reliability package with enhanced silicone resin encapsulation
- High brightness with optimum flux performance using InGaN chip technologies
- Available in Cool White
- Available in 8 mm carrier tape & 7 inch reel
- Wide viewing angle at 120 degree
- JEDEC MSL 2

Applications

- Interior automotive
 - a. Instrument panel backlighting
 - b. Central console backlighting
 - c. Navigation and audio system backlighting
 - d. Dome/Map lighting
 - e. Push button backlighting
 - f. Puddle lamp
 - g. Glove compartment illumination
- Electronic signs and signals
 - a. Decorative lighting
- Office automation, home appliances, industrial equipment
 - a. Panel/button backlighting
 - b. Display backlighting
- Others
 - Illuminations
 - Advertising board Back lighting

CAUTION: LEDs are Class 2 ESD sensitive. Please observe appropriate precautions during handling and processing.

Package Drawing

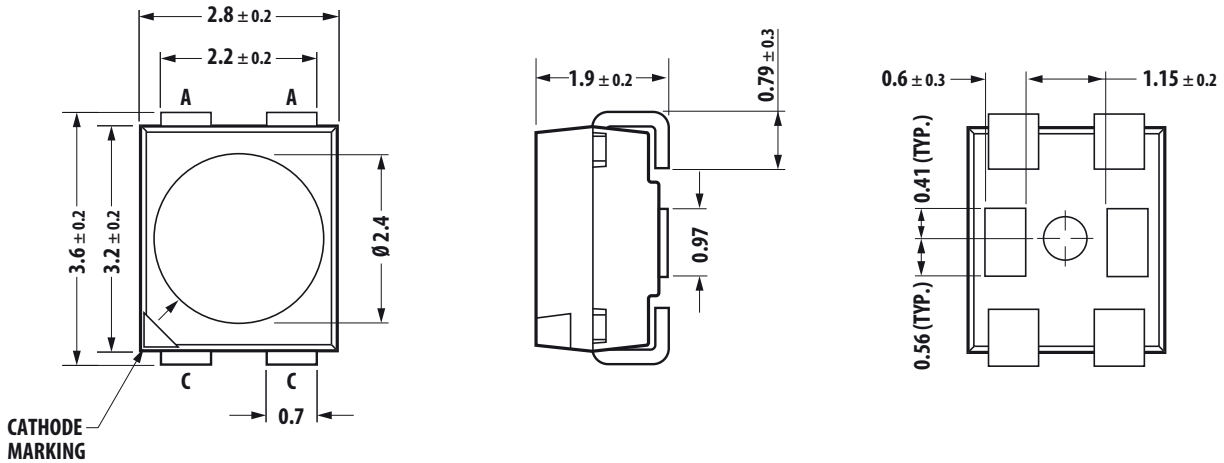

Notes:

1. All dimensions in millimeters.
2. Terminal finish: ag plating.
3. Encapsulation material: silicone resin.

Device Selection Guide ($T_J = 25^\circ\text{C}$)

Color	Part Number	Luminous Flux, θ_V^1 (lm)			Test Current (mA)	Dice Technology
		Min	Typ	Max		
Cool White	ASMT-QWBF-NKL0E	43	49	73	150	InGaN

Notes:

1. θ_V is the total luminous flux output as measured with an integrating sphere at mono pulse conditions.
2. Tolerance $\pm 12\%$.

Part Numbering System

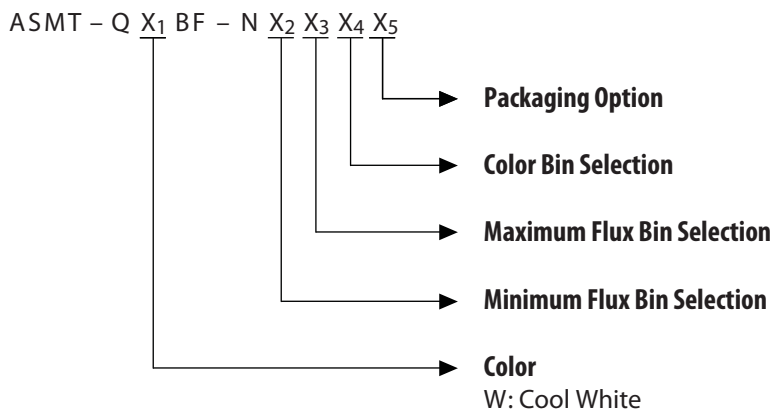

Absolute Maximum Ratings ($T_A = 25\text{ }^\circ\text{C}$)

Parameter	Rating	Unit
DC Forward Current	150	mA
Peak Forward Current ^[1]	300	mA
Power Dissipation	570	mW
Reverse Voltage	Not Recommended	V
Junction Temperature	125	$^\circ\text{C}$
Operating Temperature	-40 to +120	$^\circ\text{C}$
Storage Temperature	-40 to +120	$^\circ\text{C}$

Note:

1. Duty Factor = 10%, Frequency = 1 kHz

Optical / Electrical Characteristics ($T_J = 25\text{ }^\circ\text{C}$, $I_F = 150\text{ mA}$)

CCT (K)	Viewing Angle	Luminous Efficiency	Forward Voltage	Thermal Resistance	
	$2\theta_{1/2}$ ^[1] (Degree)	η_e (lm/W)	V_F (Volt)	Max	$R_{\theta_{J-P}}$ ($^\circ\text{C/W}$)
	Typ	Typ	Typ		
4500 ~ 10000	120	94	3.30	3.50	50

Note:

1. $\theta_{1/2}$ is the off-axis angle where the luminous intensity is $1/2$ the peak intensity.

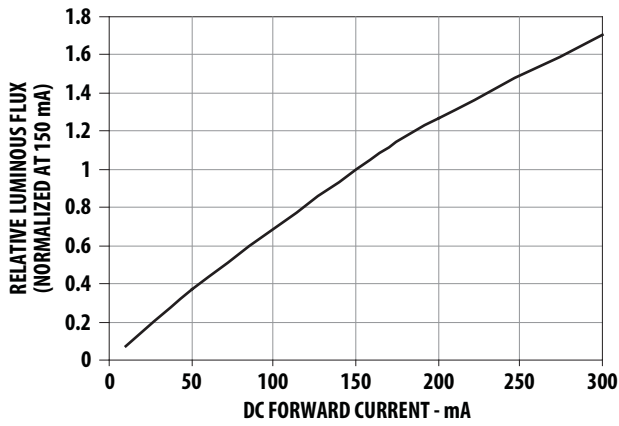

Figure 1. Relative luminous flux vs Forward current

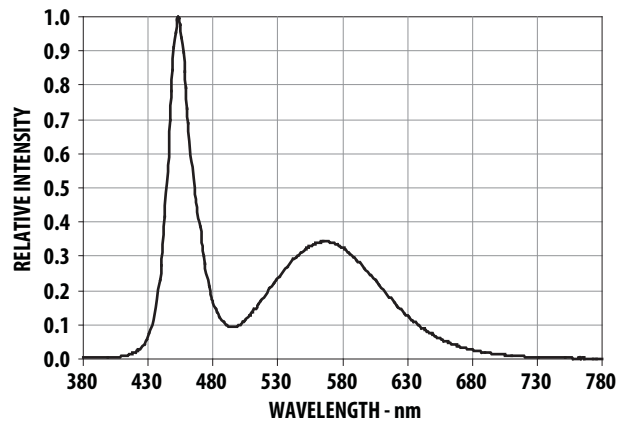

Figure 2. Color spectrum

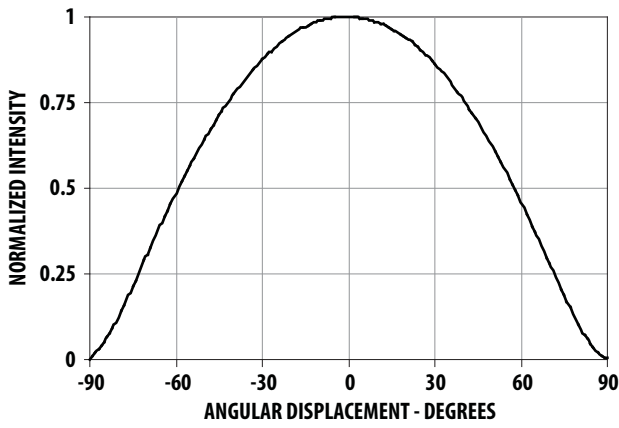

Figure 3. Radiation Pattern

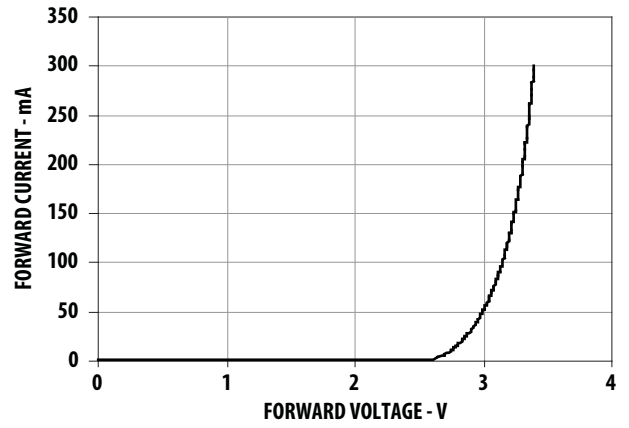

Figure 4. Forward current vs Forward voltage

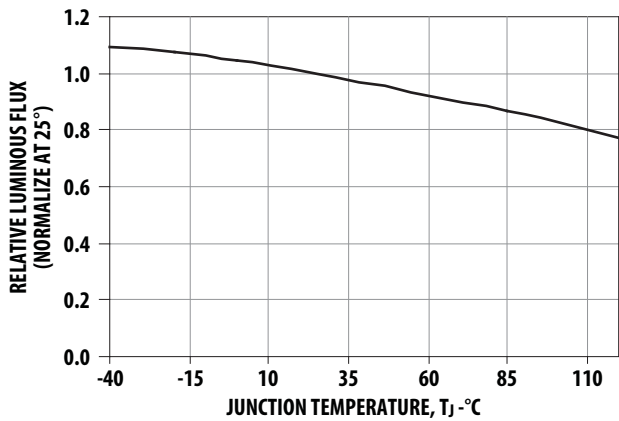

Figure 5. Relative flux vs Temperature

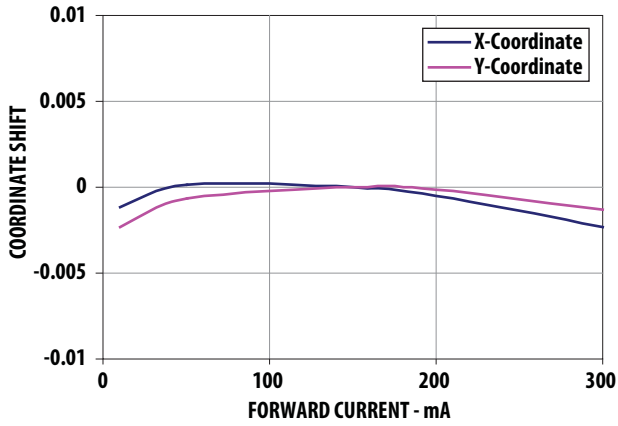

Figure 6. Chromaticity shift vs Forward current

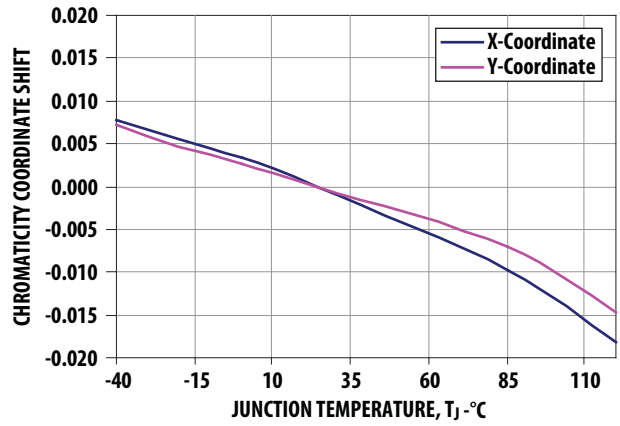

Figure 7. Chromaticity shift vs Temperature

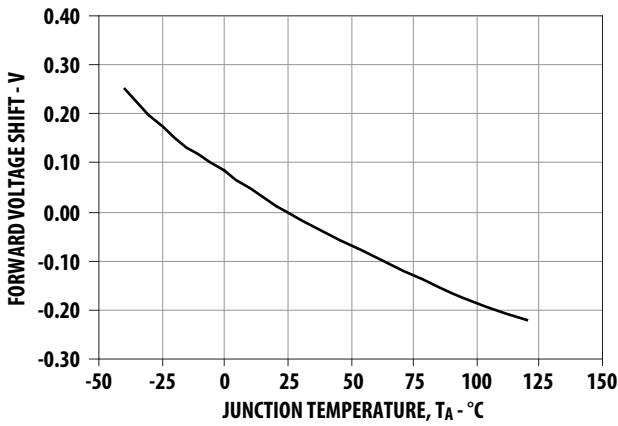

Figure 8. Relative forward voltage shift vs Temperature

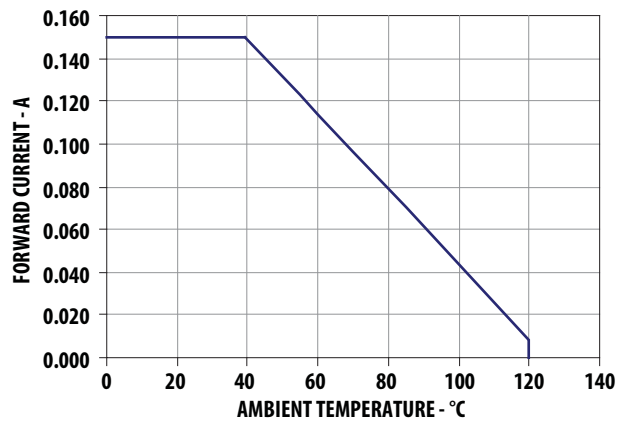

Figure 9. Maximum forward current vs. Ambient temperature. Derated base on T_{Jmax} 125° C, $R\theta_{ja}$ 150°C/W.

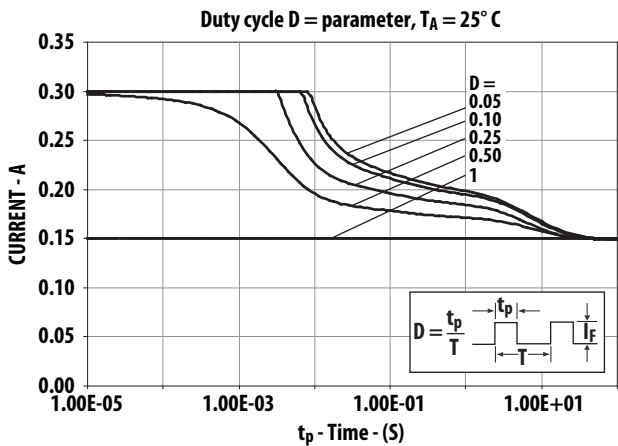

Figure 10. Maximum pulse current vs Ambient temperature $T_A = 25^\circ C$

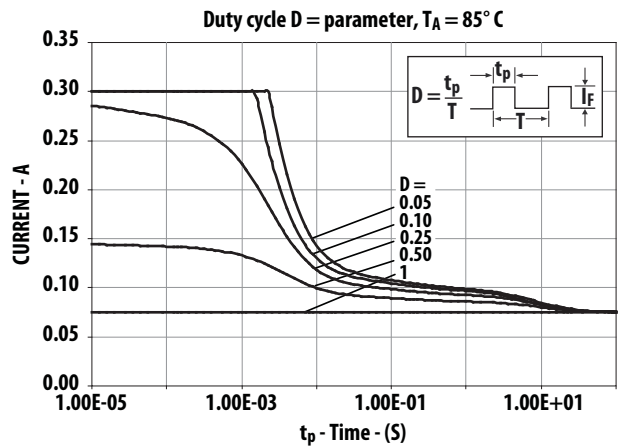
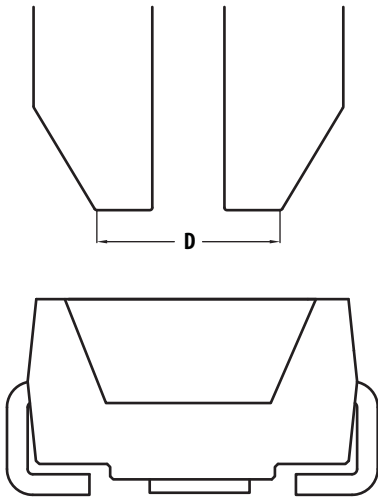
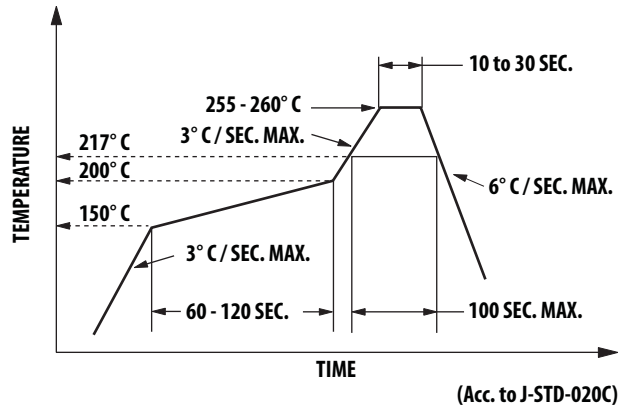

Figure 11. Maximum pulse current vs Ambient temperature $T_A = 85^\circ C$



Note: Diameter "D" should be smaller than 2.2 mm SMT LED Indicator Components

Figure 12. Recommended pick and place nozzle size



Note: For detail information on reflow soldering of Avago surface mount LEDs, do refer to Avago Application Note AN 1060 Surface Mounting

Figure 13. Recommended Pb free reflow soldering profile

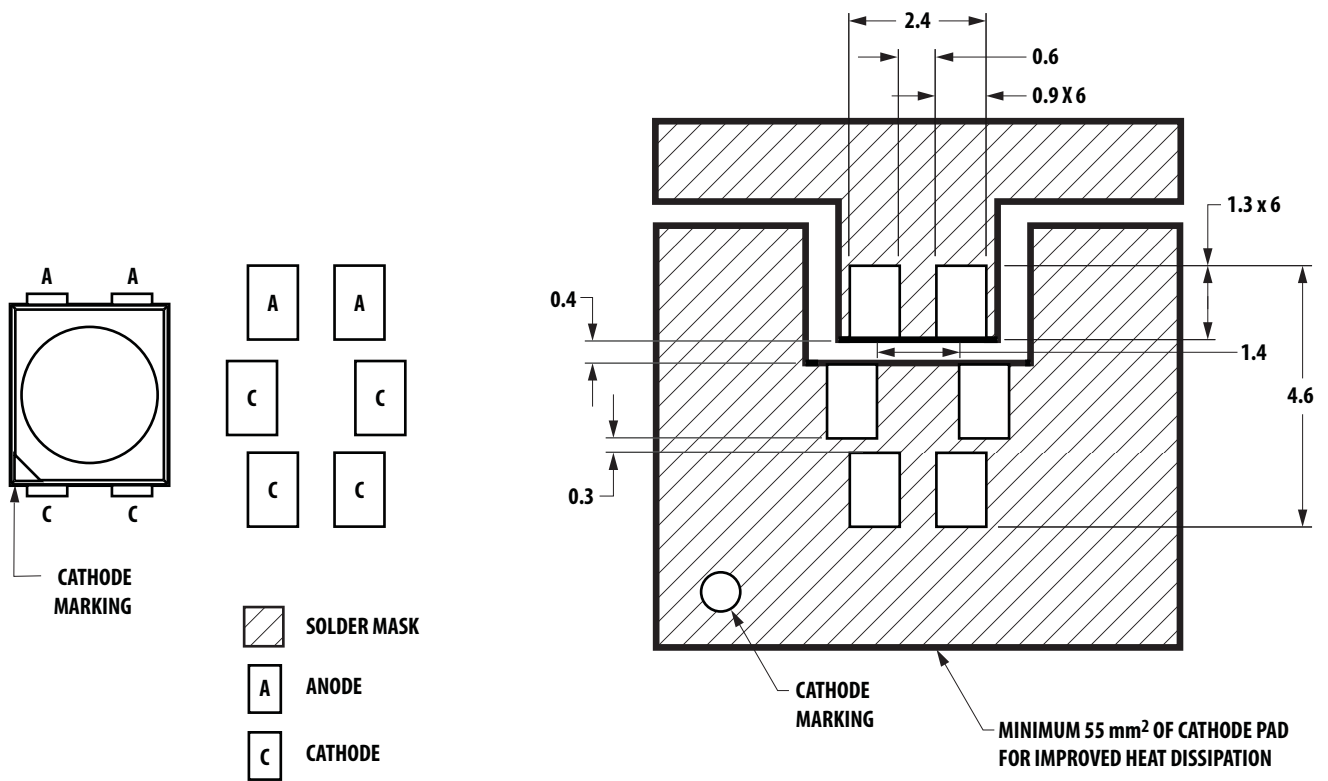

Figure 14. Recommended soldering pad pattern

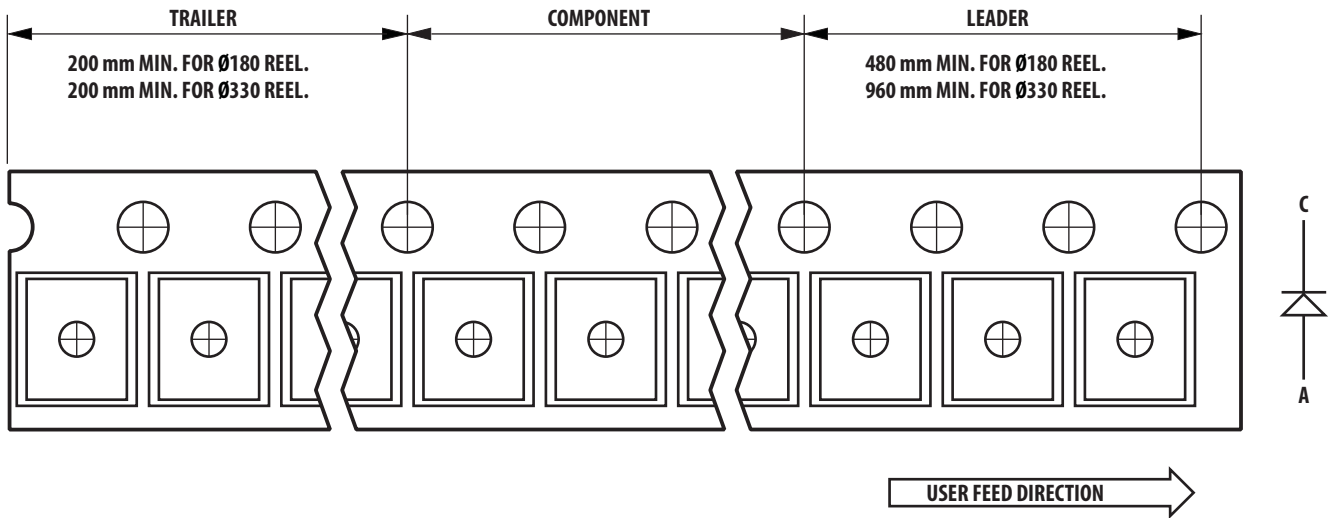

Figure 15. Tape leader and trailer dimensions

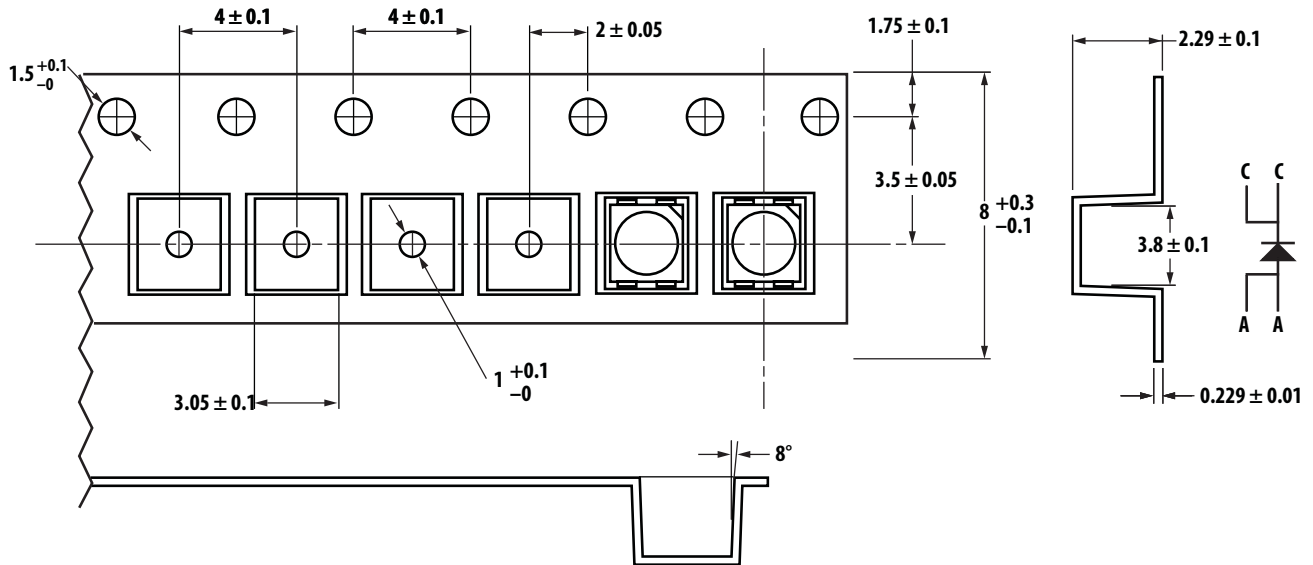

Figure 16. Tape dimensions

Handling Precaution

The encapsulation material of the product is made of silicone for better reliability of the product. As silicone is a soft material, please do not press on the silicone or poke a sharp object onto the silicone. These might damage the product and cause premature failure. During assembly or handling, the unit should be held on the body only.

Moisture Sensitivity

This product is qualified as Moisture Sensitive Level 2 per Jedec J-STD-020. Precautions when handling this moisture sensitive product is important to ensure the reliability of the product.

A. Storage before use

- Unopen moisture barrier bag (MBB) can be stored at <40°C/90%RH for 12 months. If the actual shelf life has exceeded 12 months and the HIC indicates that baking is not required, then it is safe to reflow the LEDs per the original MSL rating.
- It is not recommended to open the MBB prior to assembly (e.g. for IQC).

B. Control after opening the MBB

- The humidity indicator card (HIC) shall be read immediately upon opening of MBB.
- The LEDs must be kept at <30°C/60%RH at all time and all high temperature related process including soldering, curing or rework need to be completed within 1 year.

C. Control for unfinished reel

- For any unused LEDs, they need to be stored in sealed MBB with desiccant or desiccator at <5%RH.

D. Control of assembled boards

- If the PCB soldered with the LEDs is to be subjected to other high temperature processes, the PCB need to be stored in sealed MBB with desiccant or desiccator at <5%RH to ensure no LEDs have exceeded their floor life of 1 year.

E. Baking is required if:

- “60%” HIC indicator is NOT blue.
- The LEDs are exposed to condition of >30°C/60% RH at any time.
- The LEDs floor life exceeded 1 year.

Recommended baking condition: 60±5°C for 20 hours.

Device Color (X₁)

W	Cool White
---	------------

Flux Bin Select (X₂X₃)

Individual reel will contain parts from one bin only

X ₂	Min Flux Bin
X ₃	Max Flux Bin

Flux Bin

Bin ID	Min (lm)	Max (lm)
O	3.40	4.30
A	4.30	5.50
B	5.50	7.00
C	7.00	9.00
D	9.00	11.50
E	11.50	15.00
F	15.00	19.50
G	19.50	25.50
H	25.50	33.00
J	33.00	43.00
K	43.00	56.00
L	56.00	73.00

Tolerance ± 12%

Color Bin Select (X₄)

Individual reel will contain parts from one sub bin only.

X ₄	
0	Full Distribution
A	5K and 5L only
B	6K and 6L only
C	7K and 7L only
D	8K and 8L only
E	5K and 6K only
F	5L and 6L only
G	6K and 7K only
H	6L and 7L only
J	7K and 8K only
K	7L and 8L only
L	5K, 5L, 6K and 6L only
M	6K, 6L, 7K and 7L only
N	7K, 7L, 8K and 8L only
P	5L only
Q	6L only
R	7L only
S	8L only
T	5K only
U	6K only
V	7K only
W	8K only
Z	Special binning

Color Bin

Bin ID	Sub Bin ID	Chromaticity Coordinates				
5K	5Ka	x	0.296	0.304	0.302	0.294
		y	0.259	0.270	0.276	0.264
	5Kb	x	0.294	0.302	0.300	0.291
		y	0.264	0.276	0.281	0.268
	5Kc	x	0.304	0.313	0.312	0.302
		y	0.270	0.284	0.291	0.276
	5Kd	x	0.302	0.312	0.310	0.300
		y	0.276	0.291	0.297	0.281
5L	5La	x	0.291	0.300	0.298	0.288
		y	0.268	0.281	0.288	0.274
	5Lb	x	0.288	0.298	0.295	0.285
		y	0.274	0.288	0.294	0.279
	5Lc	x	0.300	0.310	0.309	0.298
		y	0.281	0.297	0.305	0.288
	5Ld	x	0.298	0.309	0.307	0.295
		y	0.288	0.305	0.312	0.294
6K	6Ka	x	0.313	0.322	0.321	0.312
		y	0.284	0.297	0.305	0.291
	6Kb	x	0.312	0.321	0.320	0.310
		y	0.291	0.305	0.314	0.297
	6Kc	x	0.322	0.330	0.330	0.321
		y	0.297	0.310	0.320	0.305
	6Kd	x	0.321	0.330	0.330	0.320
		y	0.305	0.320	0.330	0.314
6L	6La	x	0.310	0.320	0.319	0.309
		y	0.297	0.314	0.322	0.305
	6Lb	x	0.309	0.319	0.318	0.307
		y	0.305	0.322	0.329	0.312
	6Lc	x	0.320	0.330	0.330	0.319
		y	0.314	0.330	0.339	0.322
	6Ld	x	0.319	0.330	0.330	0.318
		y	0.322	0.339	0.347	0.329
7K	7Ka	x	0.330	0.336	0.337	0.330
		y	0.310	0.320	0.330	0.320
	7Kb	x	0.330	0.337	0.337	0.330
		y	0.320	0.330	0.341	0.330
	7Kc	x	0.336	0.343	0.344	0.337
		y	0.320	0.331	0.341	0.330
	7Kd	x	0.337	0.344	0.345	0.337
		y	0.330	0.341	0.352	0.341
7L	7La	x	0.330	0.337	0.337	0.330
		y	0.330	0.341	0.349	0.339
	7Lb	x	0.330	0.337	0.338	0.330
		y	0.339	0.349	0.358	0.347
	7Lc	x	0.337	0.345	0.346	0.337
		y	0.341	0.352	0.362	0.349
	7Ld	x	0.337	0.346	0.347	0.338
		y	0.349	0.362	0.371	0.358
8K	8Ka	x	0.343	0.351	0.352	0.344
		y	0.331	0.343	0.354	0.341
	8Kb	x	0.344	0.352	0.354	0.345
		y	0.341	0.354	0.364	0.352
	8Kc	x	0.351	0.360	0.362	0.352
		y	0.343	0.357	0.369	0.354
	8Kd	x	0.352	0.362	0.364	0.354
		y	0.354	0.369	0.380	0.364
8L	8La	x	0.345	0.354	0.355	0.346
		y	0.352	0.364	0.375	0.362
	8Lb	x	0.346	0.355	0.356	0.347
		y	0.362	0.375	0.385	0.371
	8Lc	x	0.354	0.364	0.366	0.355
		y	0.364	0.380	0.391	0.375
	8Ld	x	0.355	0.366	0.367	0.356
		y	0.375	0.391	0.401	0.385

Tolerance ± 0.01

Color Coordinates Chart

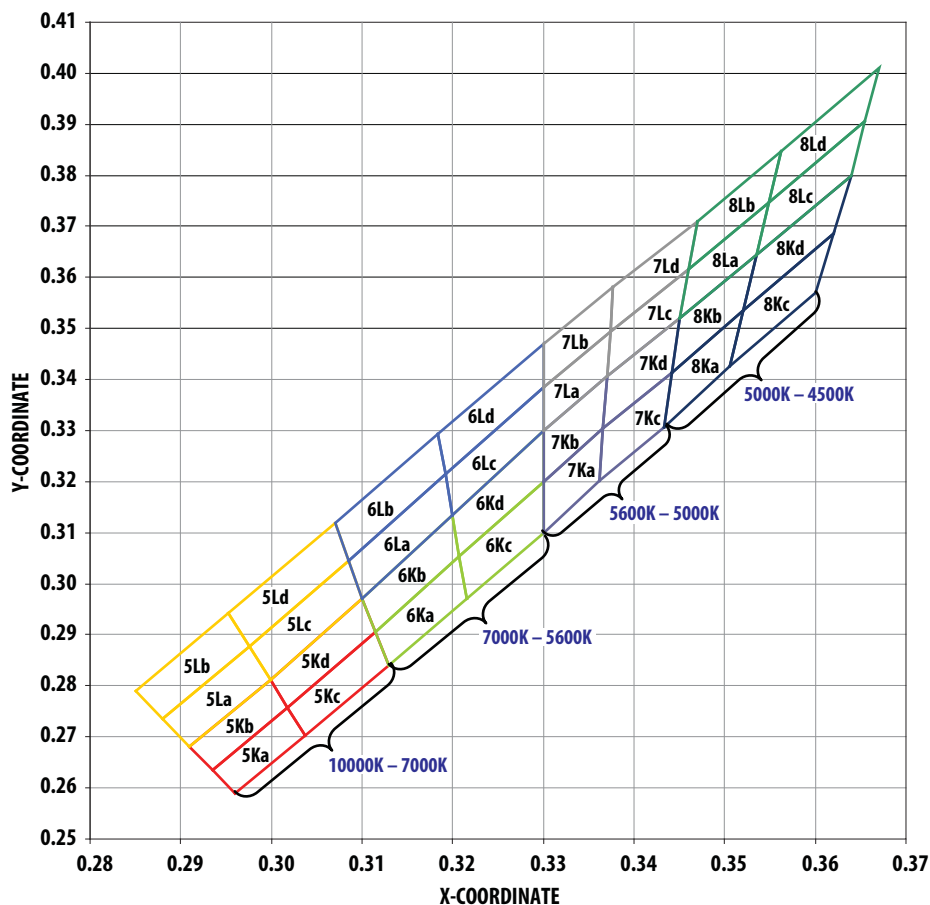

Vf Bin

Bin	Min (V)	Max (V)
S4	2.90	3.20
S5	3.20	3.50

Tolerance ± 0.1 V

Packaging Option (X₅)

Option	Test Current	Package Type	Reel Size
E	150 mA	Top Mount	7 inch

DISCLAIMER: Avago's products and software are not specifically designed, manufactured or authorized for sale as parts, components or assemblies for the planning, construction, maintenance or direct operation of a nuclear facility or for use in medical devices or applications. Customer is solely responsible, and waives all rights to make claims against avago or its suppliers, for all loss, damage, expense or liability in connection with such use.

For product information and a complete list of distributors, please go to our web site: www.avagotech.com

Avago, Avago Technologies, and the A logo are trademarks of Avago Technologies in the United States and other countries. Data subject to change. Copyright © 2005-2012 Avago Technologies. All rights reserved. AV02-3151EN - May 30, 2012

AVAGO
TECHNOLOGIES