

Data Sheet



Description

The APDS-9006 is a low cost analog-output ambient light photo sensor in a Reverse Mount, 4 pin miniature chipLED lead free surface mount package, with temperature and voltage compensation features. It consists of a spectrally suited photo sensor, which provides excellent responsivity that is close to the response of the human eyes, as shown in figure 2.

The APDS-9006 is ideal for applications in which the measurement of ambient light is used to control display backlighting such as in Note-book, mobile phone, PDA applications that draw heavy current from display backlighting will benefit from incorporating these photo sensor products in their designs by reducing power consumption significantly. Other applications include ESS, Automatic Residential and Commercial Lighting Management.

Features

- Excellent responsivity which peaks in the human luminosity curve, close responsivity to the human eye
- ChipLED surface-mount package – Reverse Mounting
 - Height – 1.10mm
 - Width – 3.20mm
 - Depth – 1.60mm
- Good output linearity across wide illumination range
- Low sensitivity variation across various light sources
- Stable performance over temperature and voltage
- Operating temperature, -40°C to 85°C
- Vcc supply 2.4 to 5.5V
- Lead-free package

Applications

- Detection of ambient light to control display backlighting
 - Mobile devices – Mobile phones, PDAs
 - Computing devices – Notebooks, Webpads
 - Consumer devices – TVs, Video Cameras, Digital Still Cameras
- Automatic Residential and Commercial Lighting Management
- Electronic Signs and Signals

Application Support Information

The Application Engineering Group is available to assist you with the application design associated with APDS-9006 ambient light photo sensor module. You can contact them through your local sales representatives for additional details.

Ordering Information

Part Number	Packaging Type	Package	Quantity
APDS-9006-020	Tape and Reel	4-pins Chiplid package	2500

Typical Application Circuit

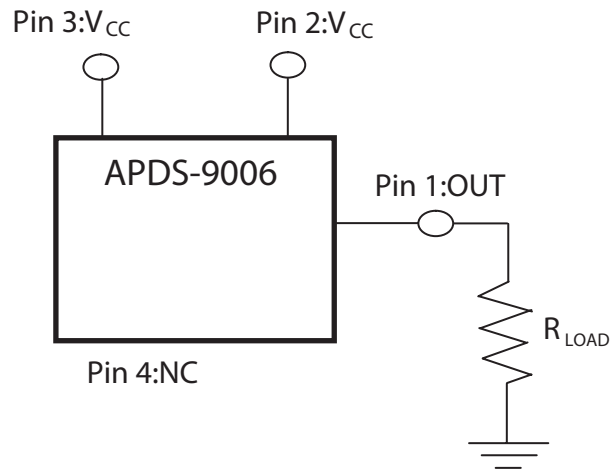

Figure 1. Typical application circuit for APDS-9006

Notes : PIN 2 and PIN 3 Vcc need to be externally shorted.

Figure 1 Table

Component	Recommended Application Circuit Component
R_{LOAD}	5k ohm

Note 1 : Refer to fig. 11 Vout vs Lux graph

I/O Pins Configuration Table

Pin	Symbol	Description
1	OUT	OUT
2	VCC	VCC
3	VCC	VCC
4	NC	No Connect

Relative Spectral Response Vs. Wavelength

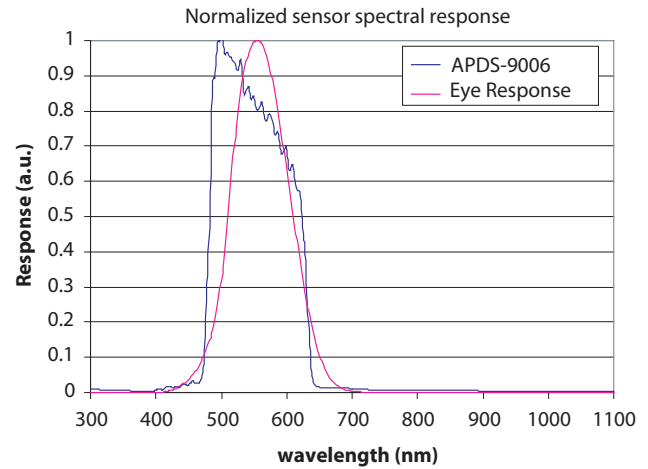

Figure 2. Relative Spectral Response Vs. Wavelength

Recommended Operating Conditions

Parameter	Symbol	Min.	Max.	Units	Conditions
Operating Temperature	T _A	-40	85	°C	
Storage Temperature	T _S	-40	85	°C	
Supply Voltage	V _{CC}	2.4	5.5	V	

Electrical & Optical Specifications (T_a=25°C)

Parameter	Symbol	Min.	Typ.	Max.	Units	Conditions
Photo Current (I)	I _{PH1}	28	40	52	uA	V _{CC} = 3V, Lux = 100 ^[1]
Photo Current (II)	I _{PH2}	-	44	-	uA	V _{CC} = 3V, Lux = 100 ^[2]
Dark Current	I _{DARK}	-	300	-	nA	V _{CC} = 3V, Lux = 0
Light Current Ratio	I _{PH2} / I _{PH1}	-	1.1	-	-	
Rise Time	T _r	-	5	-	ms	R _l = 1Kohm, Lux = 100
Fall Time	T _f	-	5	-	ms	R _l = 1Kohm, Lux=100
Peak sensitivity wavelength	λ	-	500	-	nm	
Settling Time pulsed at V _{CC}	T _{set}	-	10	-	ms	V _{CC} pulsed = 0V to 3V; R _{load} = 2.4K ohms; Lux = 100 ^[1]
Propagation delay	T _d	-	5	-	ms	R _l = 1Kohm, Lux = 100
Storage delay	T _s	-	5	-	ms	R _l = 1Kohm, Lux=100

Note :

1. Fluorescence light is used as light source, however, white LED is substituted in a mass production process
2. Illuminance by CIE standard light source (Incandescent lamp)

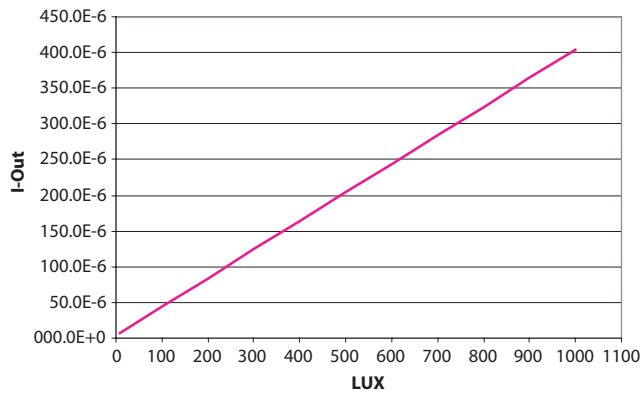

Figure 3. Average I-out Vs Lux (V_{CC} = 3V, T=25°C, White LED source)

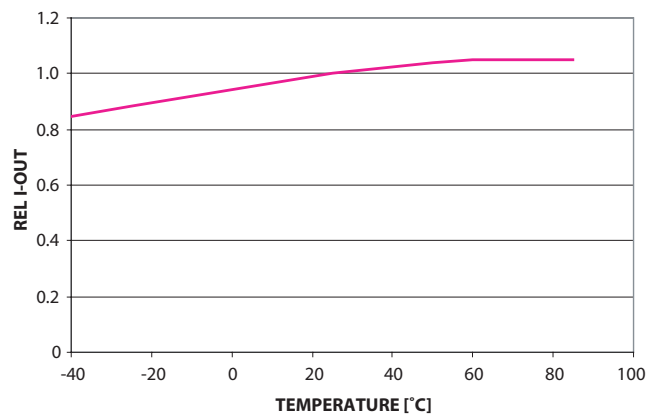

Figure 4. Average relative I-out Vs Temp (V_{CC} = 3V, T=25°C, 320 Lux)

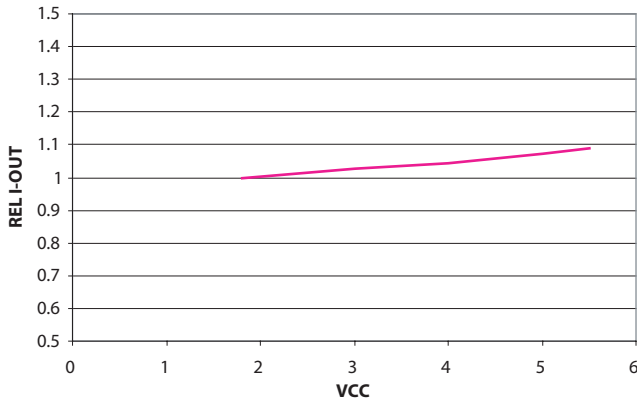

Figure 5. Relative Output Current Vs Vcc (Ta = 25°C, 100Lux)

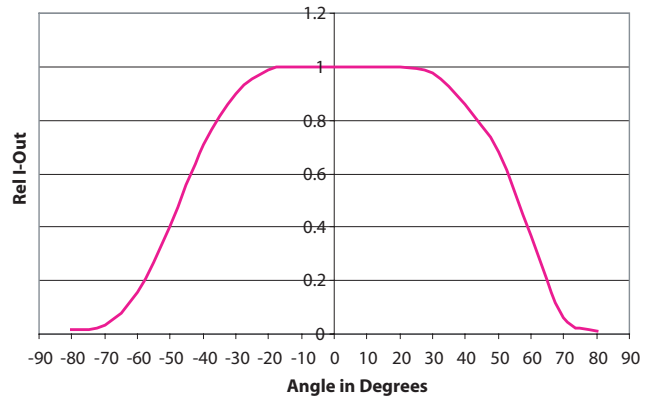

Figure 6. Relative Iout Vs Angle (Vcc = 3V, Ta = 25°C)

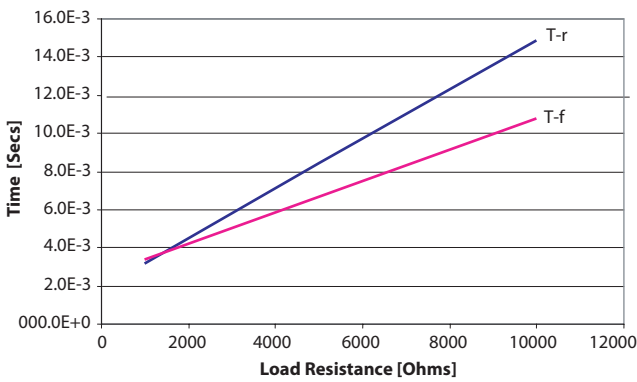

Figure 8. Average Rise Time, Fall Time Vs Load Resistance at Vcc = 3V

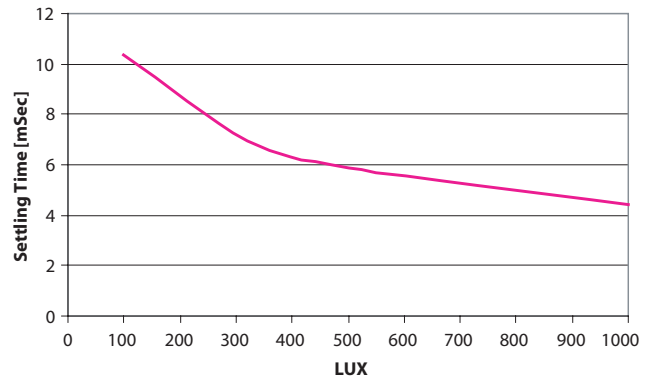

Figure 9. Average Settling Time vs Lux at Vcc=3V

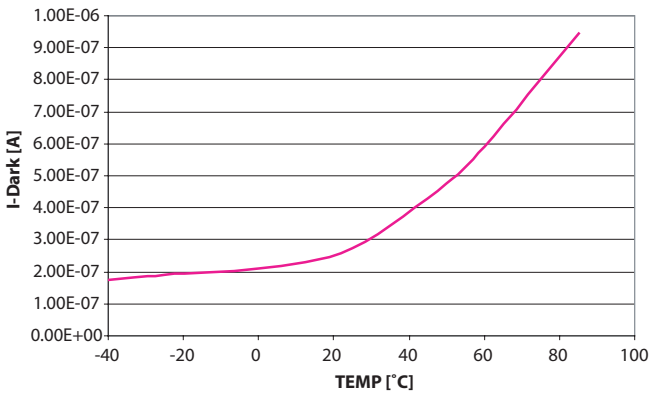

Figure 10. Dark current Vs temperature

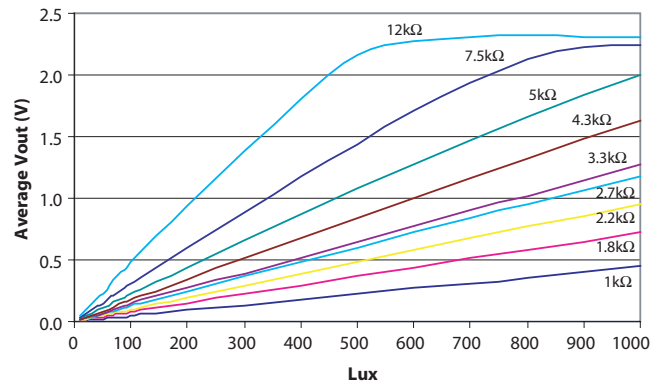
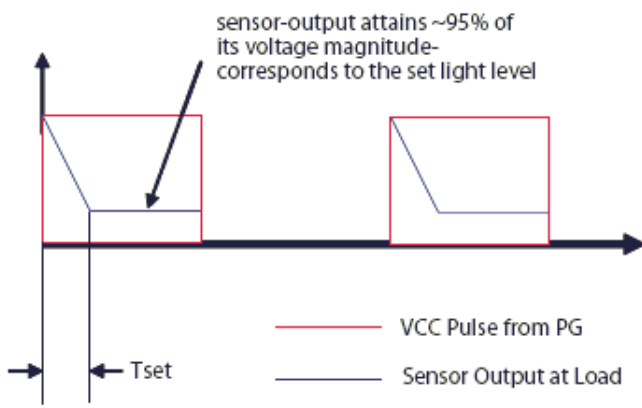
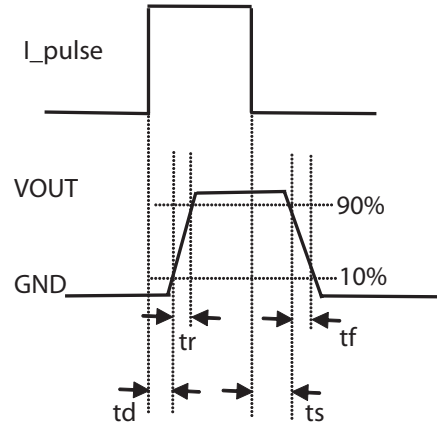
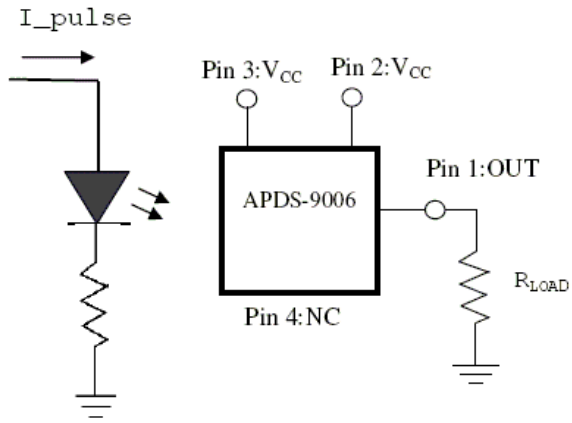
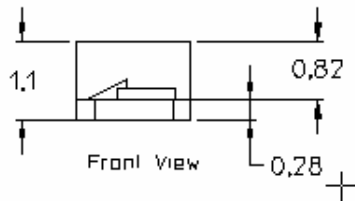
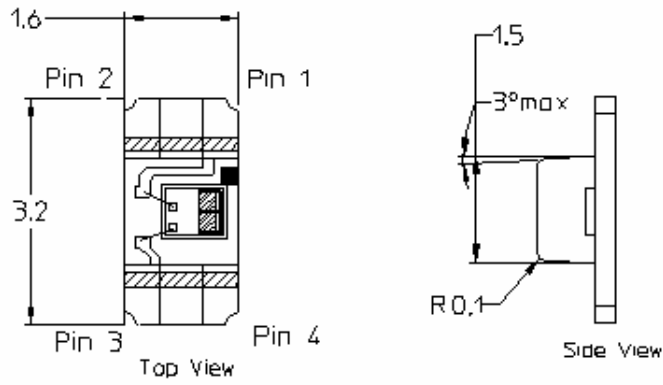

Figure 11. General Luminance vs Typical Output Voltage (Vcc = 3V, T = 25°C, Light Source = White LED)

APDS-9006 Light Measurement Circuit and Waveforms



APDS-9006 Package Outline



Light receiving area
[2 × (0.2616 × 0.2166)] mm

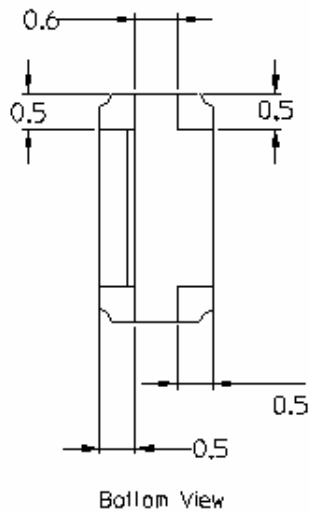

- Pin 1 ; Out
- Pin 2 ; Vcc
- Pin 3 ; Vcc
- Pin 4 ; NC

Unit = mm
Tolerances = ±0.2 mm

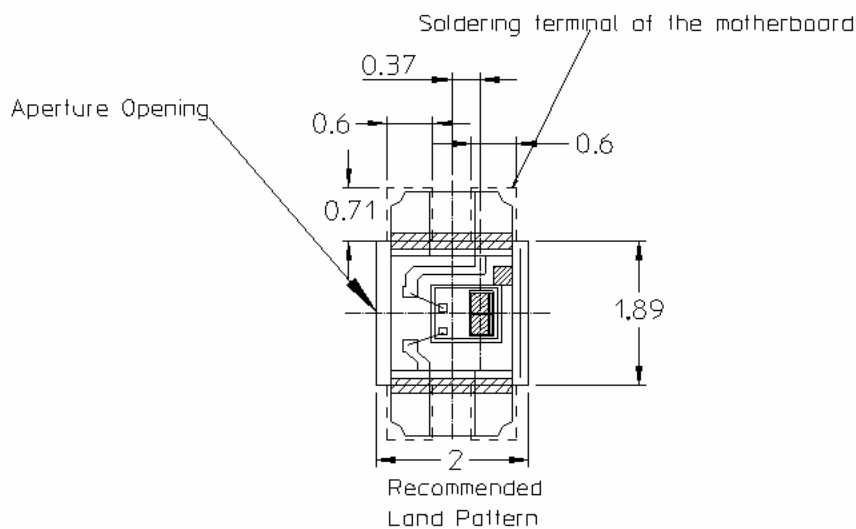

APDS-9006 Tape and Reel Dimensions

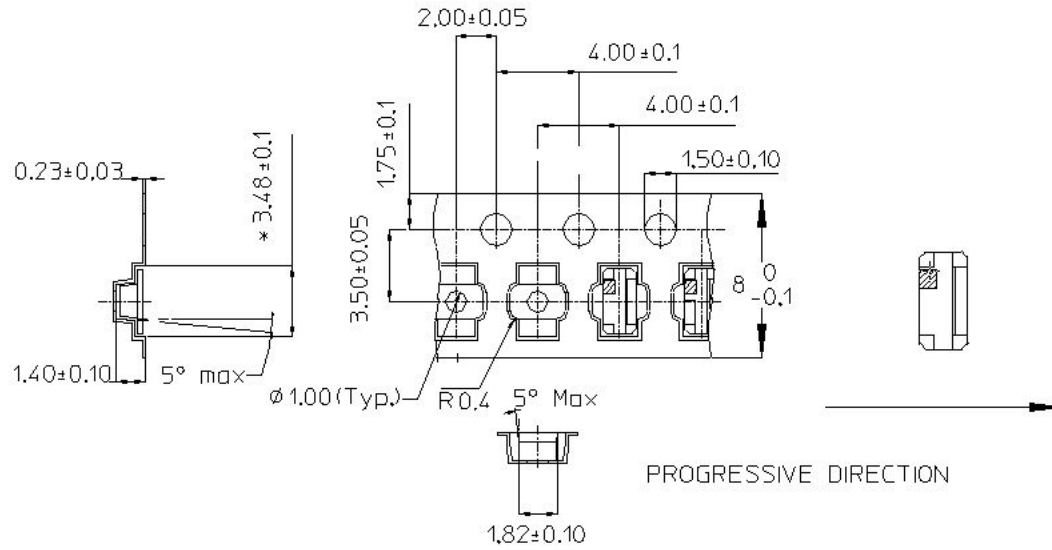

Material of Carrier Tape : Conductive Polystyrene
 Material of Cover Tape : PVC
 Method of Cover : Heat Sensitive Adhesive

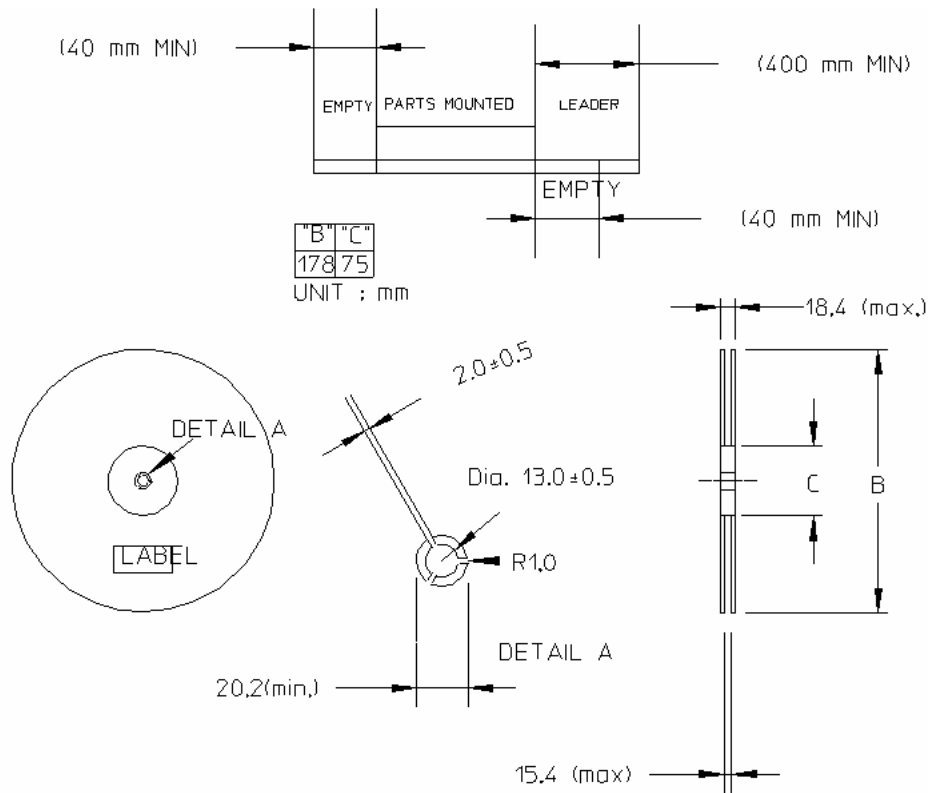

Moisture Proof Packaging Chart

All APDS-9006 options are shipped in moisture proof package. Once opened, moisture absorption begins.

This part is compliant to JEDEC Level 3.

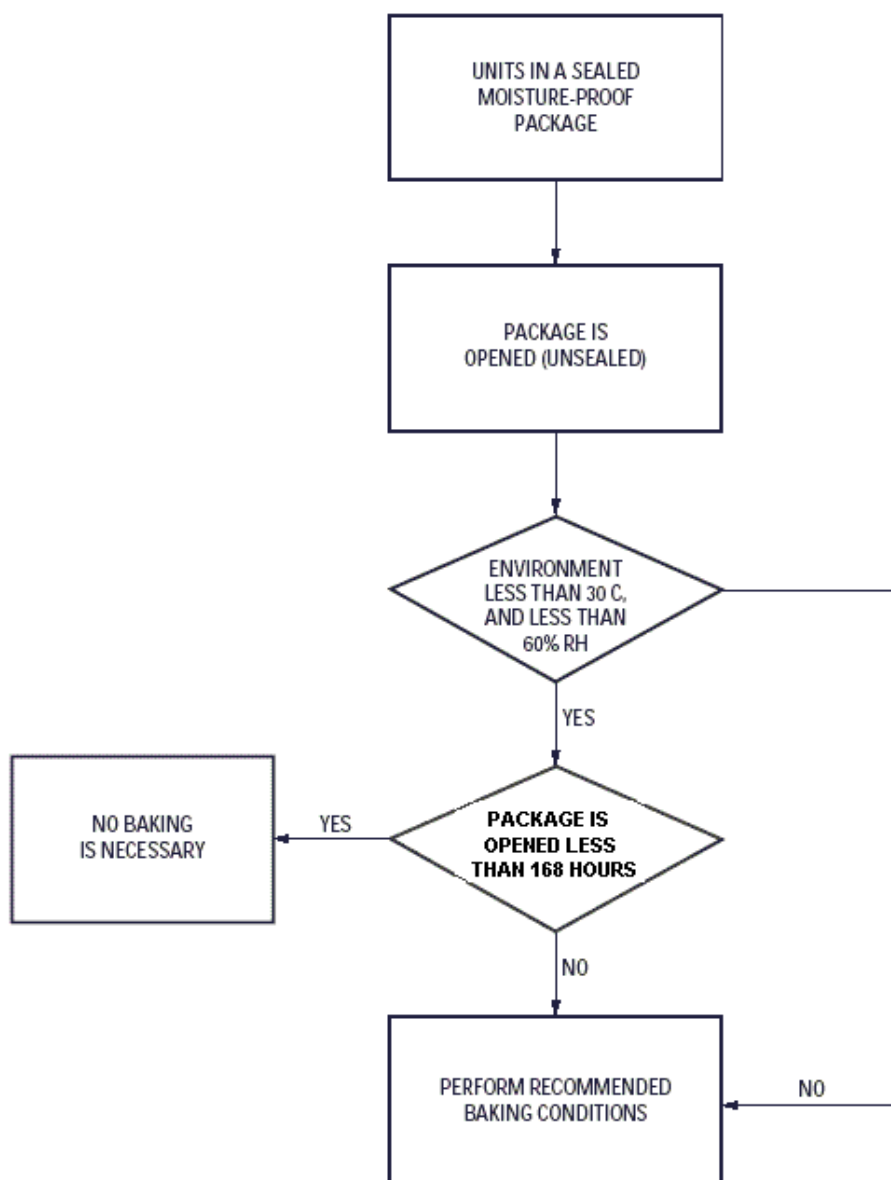

Baking conditions

If the parts are not stored in dry conditions, they must be baked before reflow to prevent damage to the parts.

Package	Temp.	Time
In Reels	60°C	48 hours
In Bulk	100°C	4 hours

Baking should only be done once.

Recommended Storage Conditions

Storage Temperature	10°C to 30°C
Relative Humidity	Below 60% RH

Time from Unsealing to Soldering

After removal from the bag, the parts should be soldered within seven days if stored at the recommended storage conditions. If times longer than seven days are needed, the parts must be stored in a dry box.

Recommended Reflow Profile

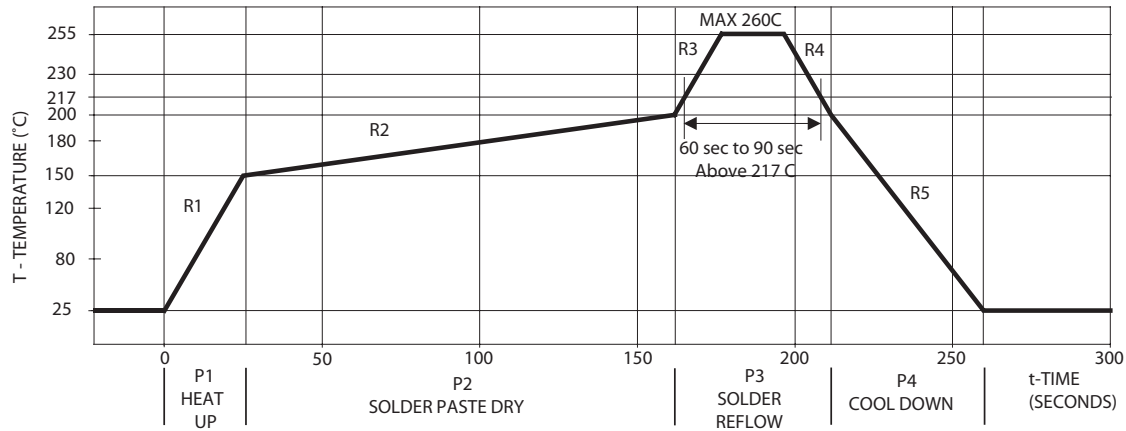

Process Zone	Symbol	ΔT	Maximum $\Delta T/\Delta \text{time}$ or Duration
Heat Up	P1, R1	25°C to 150°C	3°C/s
Solder Paste Dry	P2, R2	150°C to 200°C	100s to 180s
Solder Reflow	P3, R3	200°C to 255°C	3°C/s
	P3, R4	255°C to 200°C	-6°C/s
Cool Down	P4, R5	200°C to 25°C	-6°C/s
Time maintained above 217°C		> 217°C	60s to 90s
Peak Temperature		260°C	
Time within 5°C of actual Peak Temperature		> 255°C	20s to 40s
Time 25°C to Peak Temperature		25°C to 260°C	8mins

The reflow profile is a straight-line representation of a nominal temperature profile for a convective reflow solder process. The temperature profile is divided into four process zones, each with different $\Delta T/\Delta \text{time}$ temperature change rates or duration. The $\Delta T/\Delta \text{time}$ rates or duration are detailed in the above table. The temperatures are measured at the component to printed circuit board connections.

In process zone P1, the PC board and APDS-9006 pins are heated to a temperature of 150°C to activate the flux in the solder paste. The temperature ramp up rate, R1, is limited to 3°C per second to allow for even heating of both the PC board and APDS-9006 pins.

Process zone P2 should be of sufficient time duration (60 to 120 seconds) to dry the solder paste. The temperature is raised to a level just below the liquidus point of the solder, usually 200°C (392°F).

Process zone P3 is the solder reflow zone. In zone P3, the temperature is quickly raised above the liquidus point of solder to 255°C (491°F) for optimum results. The

dwell time above the liquidus point of solder should be between 20 and 40 seconds. It usually takes about 20 seconds to assure proper coalescing of the solder balls into liquid solder and the formation of good solder connections. Beyond a dwell time of 40 seconds, the intermetallic growth within the solder connections becomes excessive, resulting in the formation of weak and unreliable connections. The temperature is then rapidly reduced to a point below the solidus temperature of the solder, usually 200°C (392°F), to allow the solder within the connections to freeze solid.

Process zone P4 is the cool down after solder freeze. The cool down rate, R5, from the liquidus point of the solder to 25°C (77°F) should not exceed 6°C per second maximum. This limitation is necessary to allow the PC board and APDS-9006 pins to change dimensions evenly, putting minimal stresses on the APDS-9006.

It is recommended to perform reflow soldering no more than twice.

Appendix A: SMT Assembly Application Note

1.0 Solder Pad, Mask and Metal

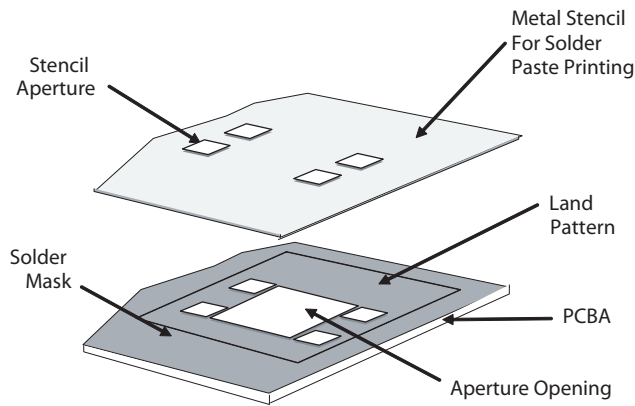

Figure A1. Stencil and PCBA

1.1 Recommended Land Pattern

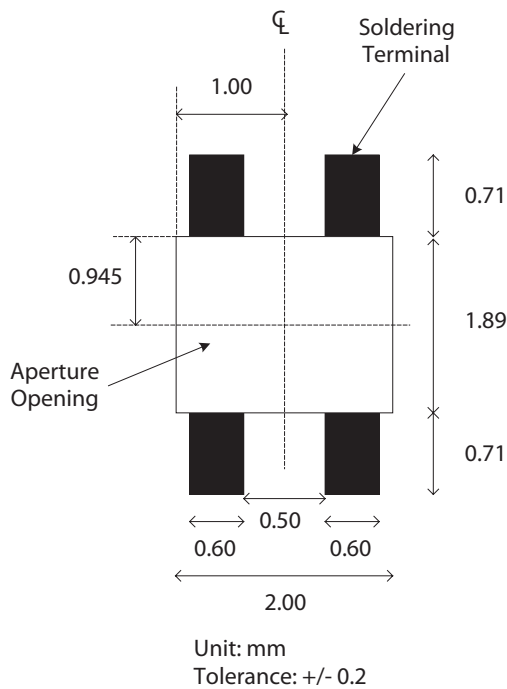

Figure A2. Recommended Land Pattern

1.2 Recommended Metal Solder Stencil Aperture

It is recommended that a 0.11 mm (0.004 inches) thick stencil be used for solder paste printing. Aperture opening for shield pad is 0.6mm x 0.71mm. This is to ensure adequate printed solder paste volume and no shorting.

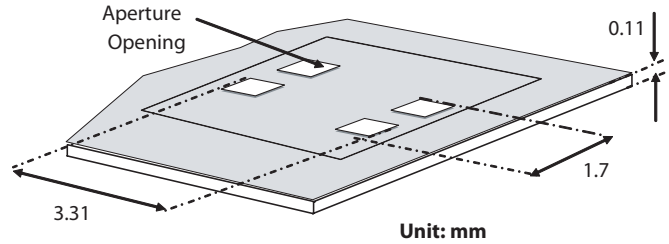

Figure A3. Solder stencil aperture

1.3 Adjacent Land Keep-out and Solder Mask Areas

Adjacent land keep-out is the maximum space occupied by the unit relative to the land pattern. There should be no other SMD components within this area.

The minimum solder resist strip width required to avoid solder bridging adjacent pads is 0.2 mm.

Note: Wet/Liquid Photo-Imageable solder resist/mask is recommended.

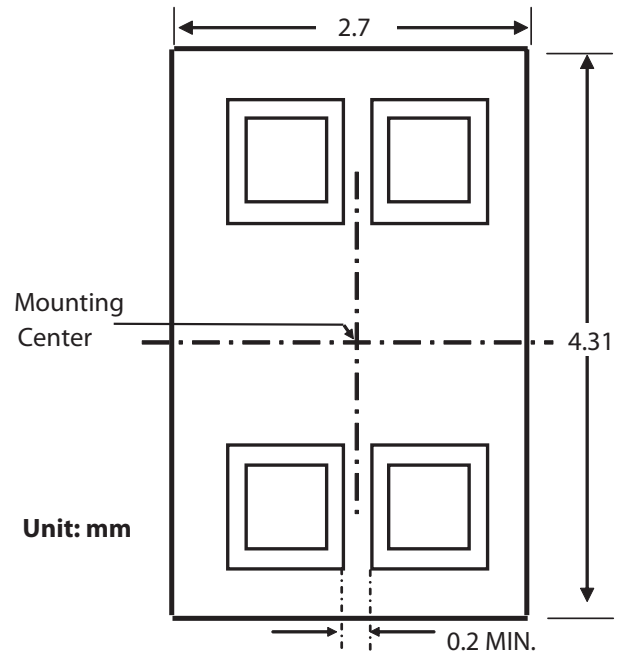

Figure A4. Adjacent land keepout and solder mask areas.

Appendix B: Optical Window Design for APDS-9006

2.0 Optical Window Dimensions

To ensure that the performance of the APDS-9006 will not be affected by improper window design, there are some constraints on the dimensions and design of the window. There is a constraint on the minimum size of the window, which is placed in front of the photo light sensor, so that it will not affect the angular response of the APDS-9006. This minimum dimension that is recommended will ensure at least a $\pm 35^\circ$ light reception cone.

If a smaller window is required, a light pipe or light guide can be used. A light pipe or light guide is a cylindrical piece of transparent plastic, which makes use of total internal reflection to focus the light.

The thickness of the window should be kept as minimum as possible because there is a loss of power in every optical window of about 8% due to reflection (4% on each side) and an additional loss of energy in the plastic material.

Figure B1 and B2 illustrate the two types of window that we have recommended which could either be a flat window or a flat window with light pipe.

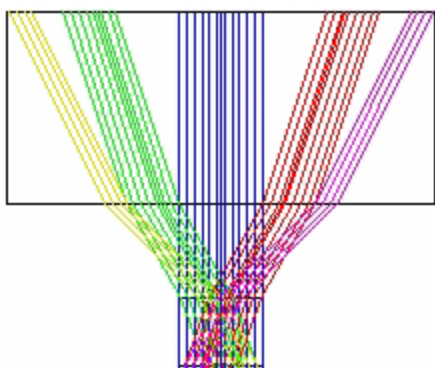

Figure B1. Window Size Determination for Flat Window

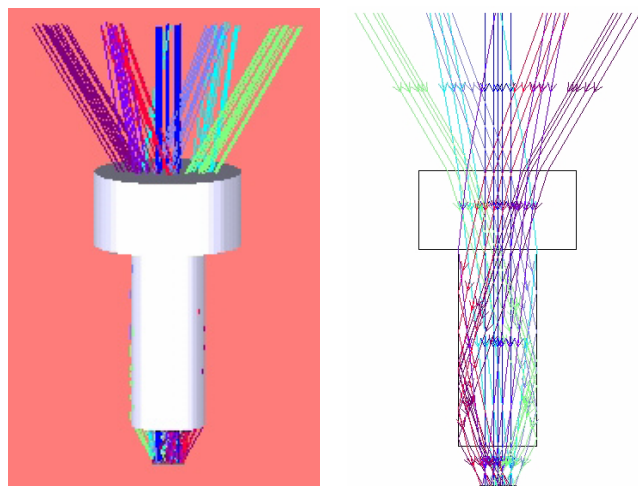

Figure B2. Window Design of Flat Window with Light Guide

Table 1 and Figure B3 below show the recommended dimensions of the window. These dimension values are based on a window thickness of 1.0mm with a refractive index 1.585.

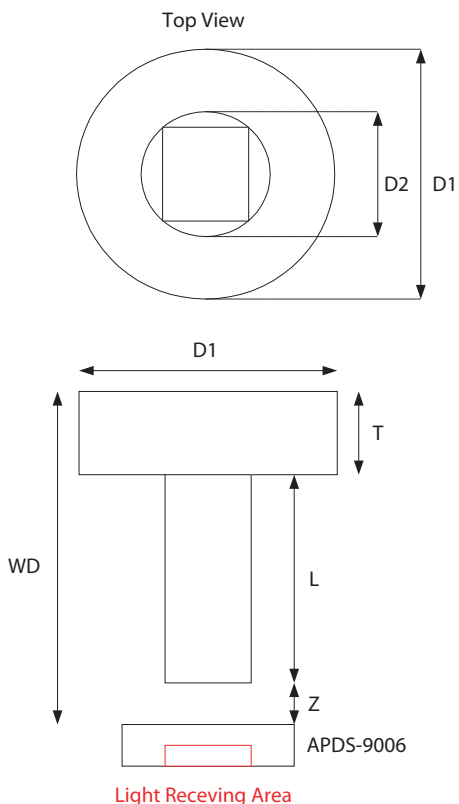

Figure B3. Recommended Window Dimensions

- WD: Working Distance between window front panel & APDS-9006
- D1: Window Diameter
- T: Thickness
- L: Length of Light Pipe
- D2: Light Pipe Diameter
- Z: Distance between window rear panel and APDS-9006

Table 1. Recommended minimum dimension for optical window

WD (T+L+Z)	Flat Window (L=0.0)		Flat window with Light Pipe	
	Z	D1	D1/D2	T/L/Z
1.5	0.5	2.35	-	-
2.0	1.0	3.05	-	-
2.5	1.5	3.75	-	-
3.0	2.0	4.45	2.25/1.5	1.0/1.5/0.5

All dimensions are in mm

The window should be placed directly on top of the light receiving area (active area) of the photo sensor to achieve better performance and if a flat window with a light pipe is used, dimension D2 should be 1.5mm to optimize the performance of APDS-9006.

The recommended minimum window dimension is based on the assumption that the center of the window and the center of the light receiving of the photo sensor are the same. It is recommended that the tolerance for assembly be considered as well. The recommended minimum window size which will take into account of the assembly tolerance is defined as:

$D1 (\text{min} + \text{assembly tolerance}) = D1_{\text{min}} + 2 * (\text{assembly tolerance})$ (Dimensions are in mm)

$D2 (\text{min} + \text{assembly tolerance}) = D2_{\text{min}} + 2 * (\text{assembly tolerance})$ (Dimensions are in mm)

2.1 Optical Window Material

The material of the window is recommended to be polycarbonate. The surface finish of the plastic should be smooth, without any texture.

The recommended plastic material for use as a window is available from Bayer AG and Bayer Antwerp N. V. (Europe), Bayer Corp.(USA) and Bayer Polymers Co., Ltd. (Thailand), as shown in Table 2.

Table 2. Recommended Plastic Materials

Material number	Visible light transmission	Refractive index
Makrolon LQ2647	87%	1.587
Makrolon LQ3147	87%	1.587
Makrolon LQ3187	85%	1.587

For product information and a complete list of distributors, please go to our web site: www.avagotech.com

Avago, Avago Technologies, and the A logo are trademarks of Avago Technologies, Limited in the United States and other countries. Data subject to change. Copyright © 2007 Avago Technologies Limited. All rights reserved.
AV02-0053EN - January 16, 2007

