

AMMP-6333

18-GHz to 33-GHz, 0.2-W Driver Amplifier
in SMT Package

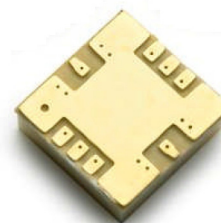

Data Sheet

Description

The AMMP-6333 is a broadband 0.2-W driver amplifier designed for use in transmitters operating in various frequency bands from 18 GHz to 33 GHz. This small, easy-to-use device provides over 23 dBm of output power (P-1dB) and more than 20 dB of gain at 25 GHz. It was optimized for linear operation with an output power at the third order intercept point (OIP3) of 30 dBm. The AMMP-6333 features a temperature compensated RF power detection circuit that enables power detection sensitivity of 0.3 V/W at 25GHz. It is fabricated using Broadcom's unique 0.25- μ m E-mode PHEMT technology, which eliminates the need for negative gate biasing voltage.

Package Diagram

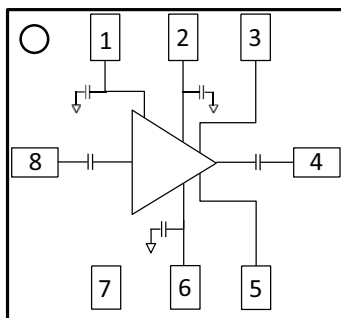

Features

- Frequency range: 18 GHz to 33 GHz
- Small signal gain: 20 dB
- P-1dB: 23 dBm
- Return loss (in/out): -10 dB

Applications

- Microwave radio systems
- Satellite VSAT, up/down link
- LMDS and Pt-Pt mmW long haul
- Broadband wireless access (including 802.16 and 802.20 WiMax)
- WLL and MMDS loops

Functional Block Diagram

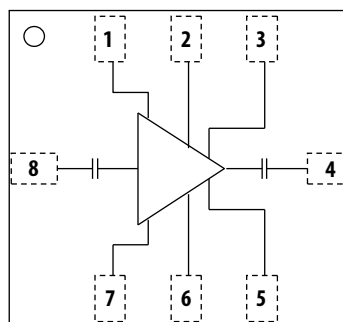

Pin	Function
1	Vg
2	Vd
3	DET_O
4	RF_out
5	DET_R
6	Vd
7	NC
8	RF_in



Attention: Observe precautions for handling electrostatic sensitive devices.

ESD Machine Model (Class A) = 90 V
ESD Human Body Model (Class 1A) = 300 V
Refer to Broadcom Application Note A004R:
Electrostatic Discharge, Damage and Control.

NOTE MSL Rating = Level 2A

Electrical Specifications

- Small/large-signal data measured in a fully de-embedded test fixture form $T_A = 25^\circ\text{C}$.
- Pre-assembly into package performance verified 100 percent on-wafer per AMMC-6220 published specifications.
- This final package part performance is verified by a functional test correlated to actual performance at one or more frequencies.
- Specifications are derived from measurements in a 50Ω test environment. Aspects of the amplifier performance may be improved over a more narrow bandwidth by application of additional conjugate, linearity, or low noise (opt) matching.
- All tested parameters guaranteed with measurement accuracy ± 2 dB for P1dB of 17.25 and 32 GHz ± 0.5 for Gain of 17 GHz, ± 1 dB for Gain of 25 and 32 GHz.

RF Electrical Characteristics

$T_A = 25^\circ\text{C}$, $V_d = 5.0\text{V}$, $I_d(Q) = 230$ mA, $Z_{in} = Z_o = 50\Omega$.

Table 1 RF Electrical Characteristics

Parameter	17 GHz–20 GHz			20 GHz–30 GHz			30 GHz–33 GHz			Unit	Comment
	Min.	Typ.	Max.	Min.	Typ.	Max.	Min.	Typ.	Max.		
Small Signal Gain, Gain	14	16	—	19	22	—	18	20.5	—	dB	
Output Power at 1-dB Gain Compression, P1dB	18	20.5	—	22	24.5	—	21	24	—	dBm	
Output Power at 3-dB Gain Compression, P3dB	—	21.5	—	—	24.5	—	—	23.5	—	dBm	
Output Third Order Intercept Point, OIP3	—	30	—	—	30	—	—	30	—	dBm	
Reverse Isolation, Iso	—	45	—	—	45	—	—	45	—	dB	
Input Return Loss, R _{lin}	—	10	—	—	10	—	—	8	—	dB	
Output Return Loss, R _{lout}	—	10	—	—	14	—	—	10	—	dB	

Recommended Operating Range

- Ambient operational temperature $T_A = 25^\circ\text{C}$ unless otherwise noted.
- Channel-to-backside thermal resistance ($T_{\text{channel}}(T_c) = 34^\circ\text{C}$) as measured using infrared microscopy. Thermal resistance at backside temperature ($T_b = 25^\circ\text{C}$) calculated from measured data.

Table 2 Recommended Operating Range

Description	Min.	Typical	Max.	Unit	Comments
Drain Supply Current, I_d	—	230	—	mA	$V_d = 5\text{V}$, V_g set for typical I_dQ – quiescent current
Gate Supply Operating Voltage, V_g	—	2	—	V	$I_dQ = 230$ mA
Gate Supply Current, I_g	—	7	—	mA	

Thermal Properties

Table 3 Thermal Properties

Parameter	Test Conditions	Value
Maximum Power Dissipation	Tbaseplate = 85°C	PD = 2.5W, Tchannel = 150°C
Thermal Resistance, θ_{jc}	Vd = 5V, Id = 230 mA, PD = 1.15W, Tbaseplate = 85°C	θ_{jc} = 27 °C/W, Tchannel = 116°C
Thermal Resistance, θ_{jc} Under RF Drive	Vd = 5V, Id = 400 mA, Pout = 24 dBm, PD = 2W, Tbaseplate = 85°C	θ_{jc} = 27 °C/W, Tchannel = 139°C

Absolute Minimum and Maximum Ratings

Table 4 Minimum and Maximum Ratings^a

Description	Min.	Max.	Unit	Comments
Drain to Gate Voltage, Vd-Vg	—	14	V	
Positive Supply Voltage, Vd	—	5.5	V	
Gate Supply Voltage, Vg	—	0 to 2.5	V	
Power Dissipation, PD	—	2.5	W	
CW Input Power, Pin	—	20	dBm	
Channel Temperature, Tch	—	+150	°C	
Storage Temperature, Tstg	-65	+155	°C	
Maximum Assembly Temperature, Tmax	—	320	°C	30 second maximum

a. Operation in excess of any one of these conditions may result in permanent damage to this device.

Typical Performance

($T_A = 25^\circ\text{C}$, $V_d = 5\text{V}$, $I_{dQ} = 230\text{ mA}$, $Z_{in} = Z_{out} = 50\Omega$)

(Data obtained from a test fixture with 2.4-mm connectors. Effects of the test fixture—losses and mismatch—have not been removed from the data.)

Figure 1 Gain and Reverse Isolation vs. Frequency

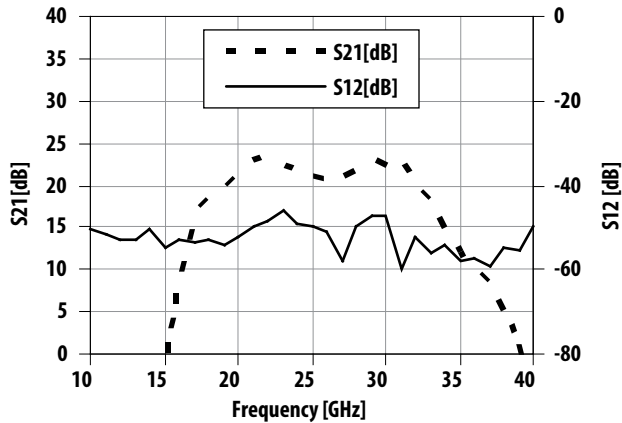

Figure 2 Return Loss vs. Frequency

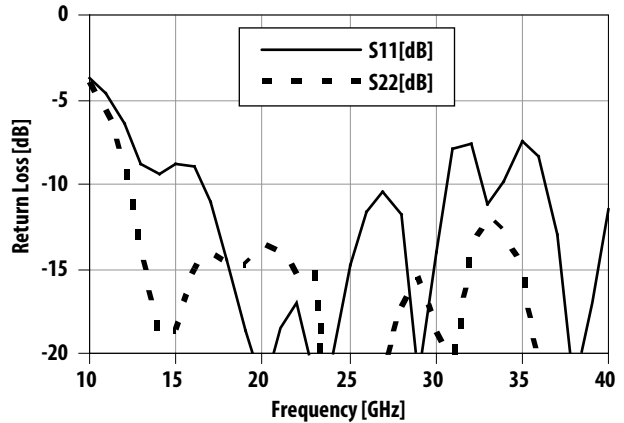

Figure 3 P_{-1dB} and PAE vs. Frequency

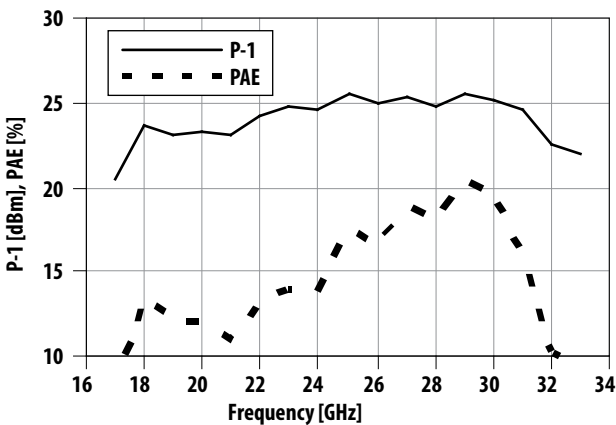

Figure 4 Typical IMD3 vs. Frequency (SCL = Single Carrier Level)

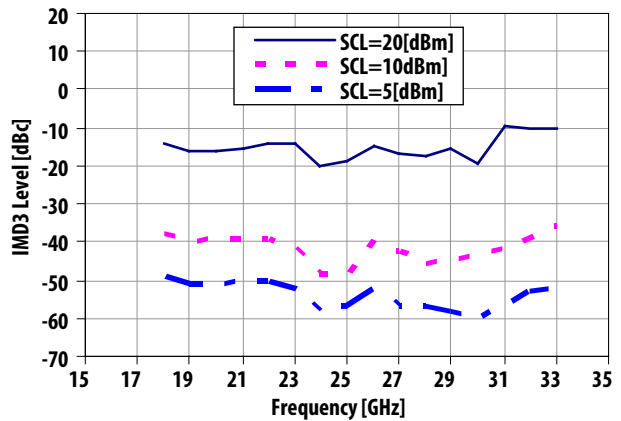

Figure 5 Typical Noise Figure vs. Frequency

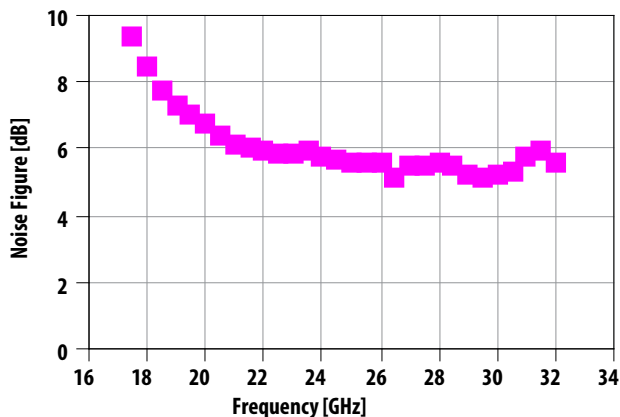
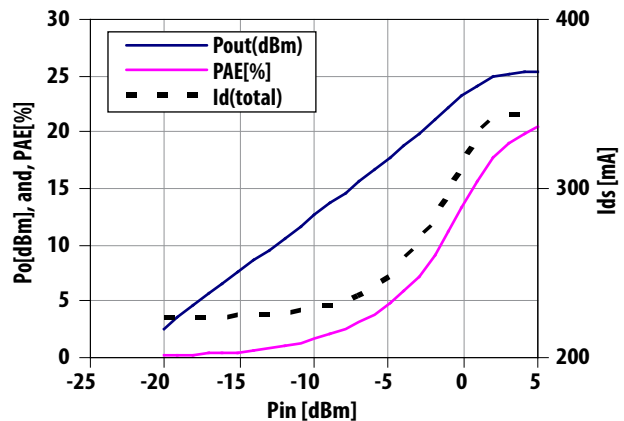

Figure 6 Output Power, PAE, and Drain Current vs. Input Power at 30 GHz



Typical Performance (continued)

(TA = 25°C, Z_{in} = Z_{out} = 50Ω)

(Data obtained from a test fixture with 2.4-mm connectors. Effects of the test fixture—losses and mismatch—have not been removed from the data.)

Figure 7 P_{-1dB} vs. Frequency and V_{ds}, (I_{dQ} = 230mA)

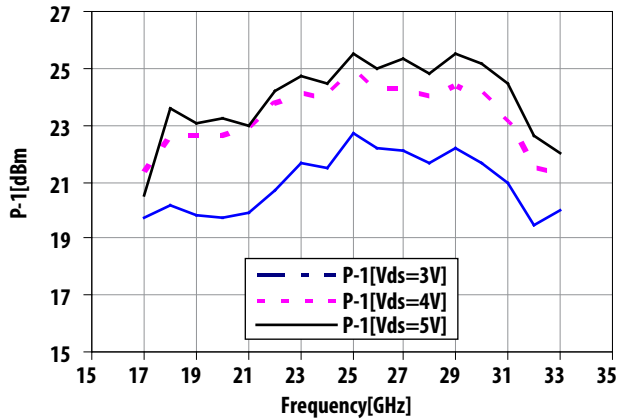

Figure 8 Small Signal Gain vs. Frequency and I_{dQ}, (V_{ds} = 5 V)

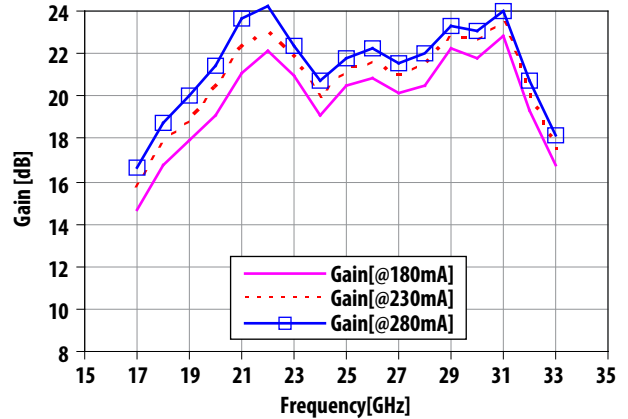

Figure 9 Small Signal Gain vs. Frequency and V_{ds}, (I_{dQ} = 230 mA)

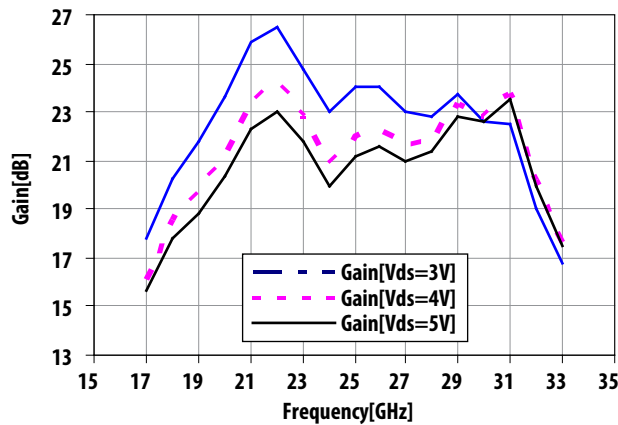
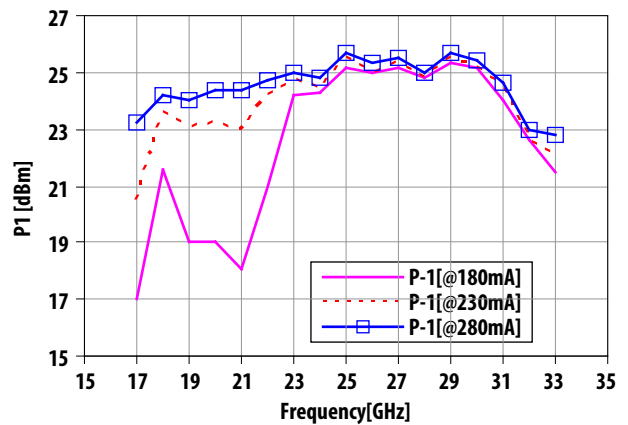

Figure 10 P_{-1dB} vs. Frequency and I_{dQ}, (V_{ds} = 5V)



Typical Performance (continued)

(TA = 25°C, Z_{in} = Z_{out} = 50Ω)

(Data obtained from a test fixture with 2.4-mm connectors. Effects of the test fixture—losses and mismatch—have not been removed from the data.)

Figure 11 |S11| vs. Frequency and Temperature

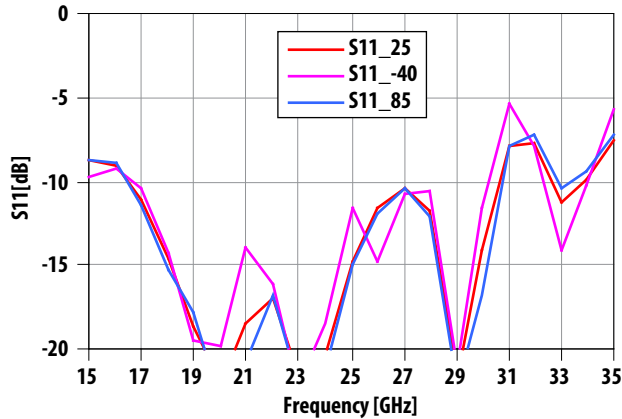

Figure 12 |S22| vs. Frequency and Temperature

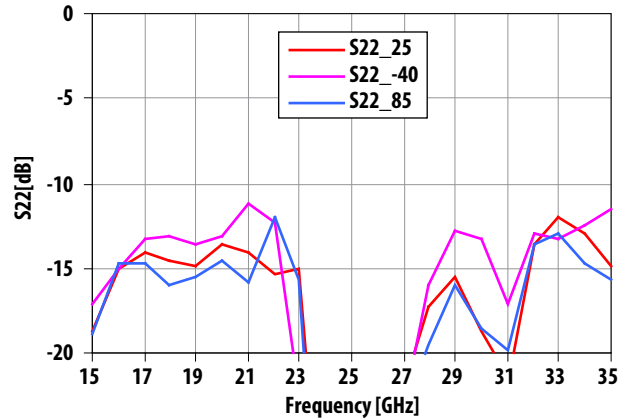

Figure 13 |S21| vs. Frequency and Temperature

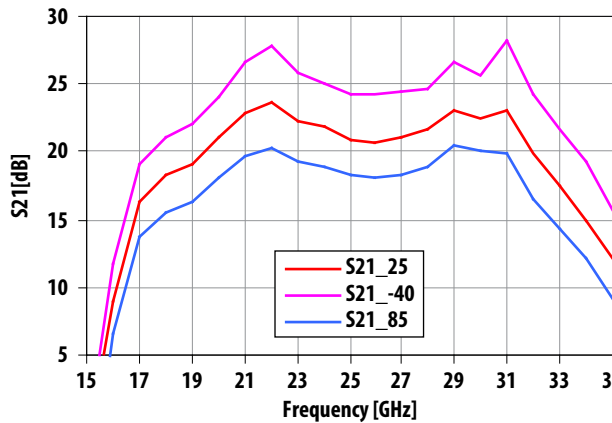
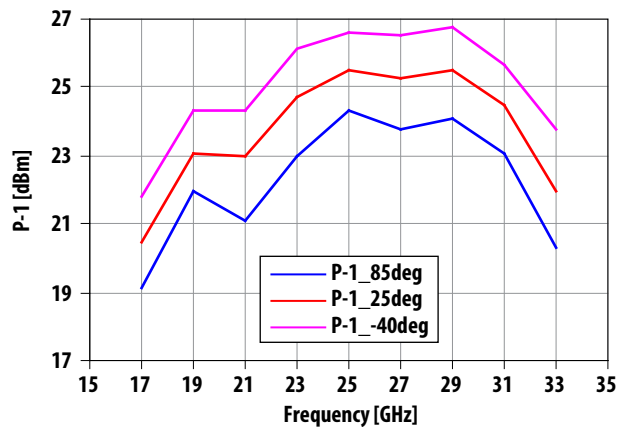

Figure 14 P_{-1dB} vs. Frequency and Temperature



Biasing Considerations

The AMMP-6333 is a balanced amplifier consisting of two four-stage single-ended amplifiers, two Lange couplers, a power monitoring detector, a reference detector for temperature compensation, and a current mirror for the gate biasing (Figure 15).

The recommended quiescent DC bias conditions for optimum gain, output power, efficiency, and reliability are: $V_d = 5V$ with V_g set for $I_{dQ} = 230$ mA. The drain bias voltage range is from 3V to 5V. Drain current range is from 200 mA to 350 mA. The AMMC-6333 can be biased with a dual or single positive DC source (Figure 16).

The output power detection network provides a way to monitor output power. The differential voltage between the DET_R and DET_O outputs can be correlated with the RF power emerging from the RF output port. This voltage is given by:

$$V = (V_{DET_R} - V_{DET_O}) - V_{OFS}$$

Where:

V_{DET_R} is the voltage at the DET_R port

V_{DET_O} is a voltage at the DET_O port

V_{OFS} is the offset voltage at zero input power

The offset voltage (V_{OFS}) can be at each power level by turning off the input power and measuring V . The error due to temperature drift should be less than 0.01 dB/50°C. When V_{OFS} is determined at a single reference temperature the drift error should be less than 0.25 dB. Finally, V_{OFS} be characterized over a range of temperatures and stored in a lookup table, or it can be measured at two temperatures and a linear fit used to calculate V_{OFS} at any temperature.

The RF ports are AC coupled at the RF input to the first stage and the RF output of the final stage. No ground wires are needed since ground connections are made with plated through-holes to the backside of the device.

Figure 15 AMMC-6333 Schematic

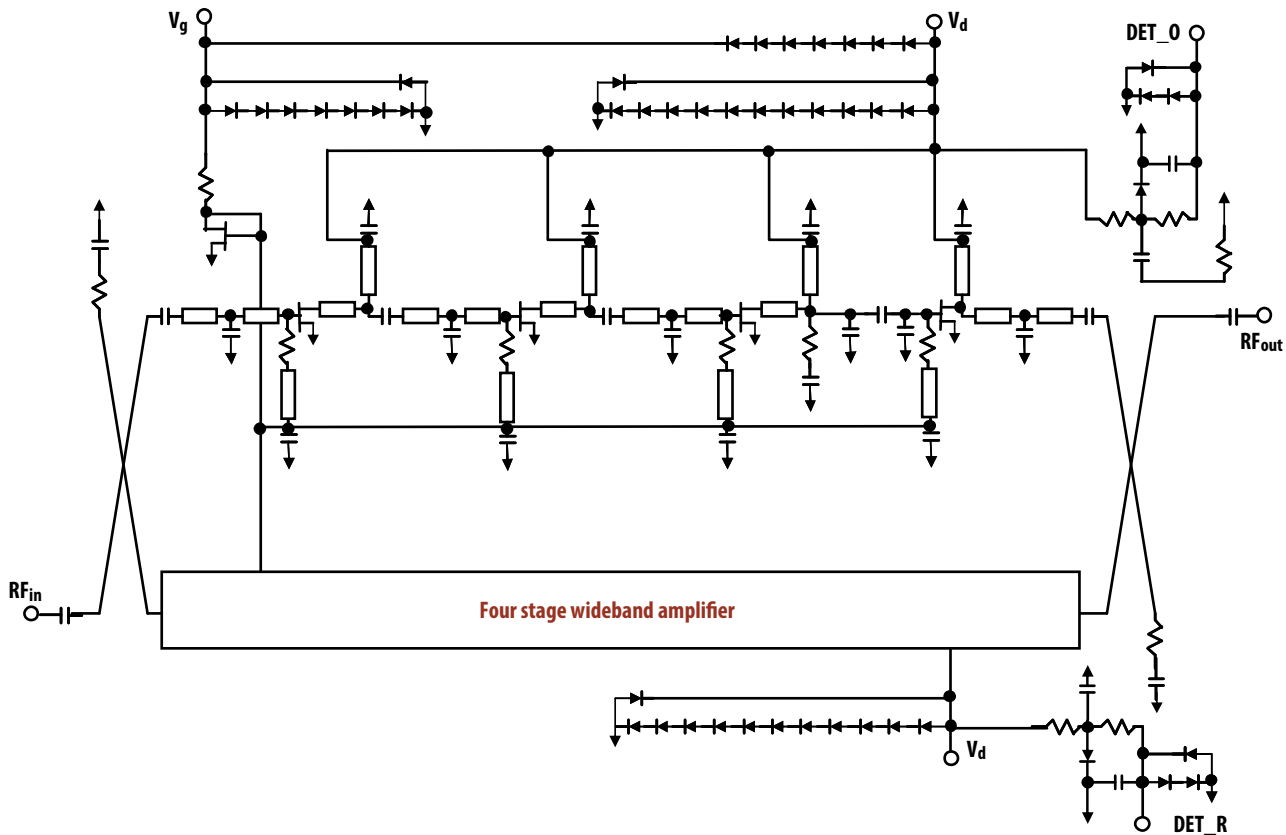
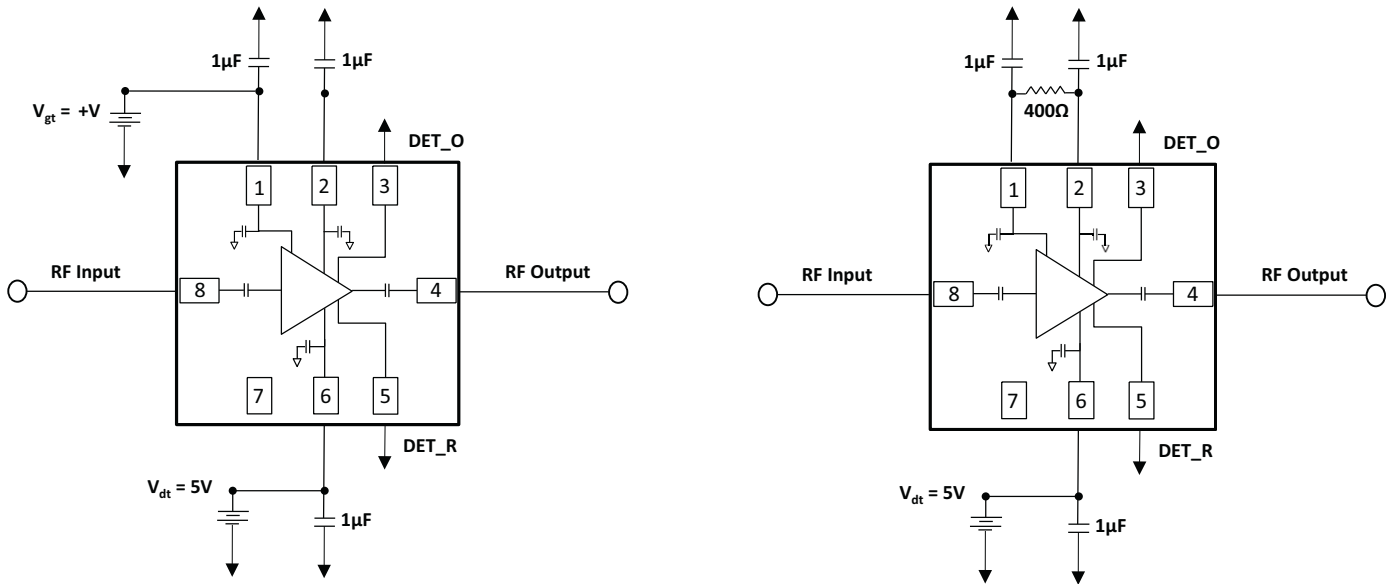

Figure 16 AMMP-6333 Assembly Examples, Vd Pins Must Be Biased from Both Sides



1. Dual DC Power Supply

NOTE Either Pin 2 or Pin 6 may be used for V_{dt} .

2. Single Positive DC Power Supply

NOTE Either Pin 2 or Pin 6 may be used for V_{dt} .

Figure 17 AMMP-6333 Typical Detector Voltage and Output Power, Freq=30 GHz

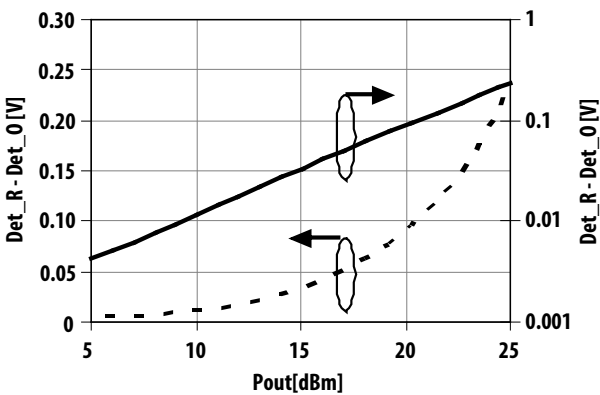

Typical Scattering Parameters

Refer to <http://www.broadcom.com> for typical scattering parameters data.

Package Dimension, PCB Layout, and Tape and Reel information

Refer to Broadcom Application Note 5520, AMxP-xxxx Production Assembly Process (Land Pattern A).

Ordering Information

Table 5 Ordering Information

Part Number	Devices Per Container	Container
AMMP-6333-BLKG	10	Antistatic bag
AMMP-6333-TR1G	100	7-in. Reel
AMMP-6333-TR2G	500	7-in. Reel

For product information and a complete list of distributors, please go to our web site: www.broadcom.com.

Broadcom, the pulse logo, Connecting everything, Avago Technologies, Avago, and the A logo are among the trademarks of Broadcom and/or its affiliates in the United States, certain other countries and/or the EU.

Copyright © 2014–2017 by Broadcom. All Rights Reserved.

The term "Broadcom" refers to Broadcom Limited and/or its subsidiaries. For more information, please visit www.broadcom.com.

Broadcom reserves the right to make changes without further notice to any products or data herein to improve reliability, function, or design.

Information furnished by Broadcom is believed to be accurate and reliable. However, Broadcom does not assume any liability arising out of the application or use of this information, nor the application or use of any product or circuit described herein, neither does it convey any license under its patent rights nor the rights of others.

AV02-1447EN – March 20, 2017

