

AMC7836 High-Density, 12-Bit Analog Monitor and Control Solution With Multichannel ADC, Bipolar DACs, Temperature Sensor, and GPIO Ports

1 Features

- 16 Monotonic 12-Bit DACs
 - Selectable Ranges: -10 V to 0 V , -5 V to 0 V , 0 V to 5 V , and 0 V to 10 V
 - High Current Drive Capability: up to $\pm 15\text{ mA}$
 - Auto-Range Detector
 - Selectable Clamp Voltage
- 12-Bit SAR ADC
 - 21 External Analog Inputs
 - 16 Bipolar Inputs: -12.5 V to $+12.5\text{ V}$
 - 5 High-Precision Inputs: 0 V to 5 V
 - Programmable Out-of-Range Alarms
- Internal 2.5-V Reference
- Internal Temperature Sensor
 - -40°C to $+125^{\circ}\text{C}$ Operation
 - $\pm 2.5^{\circ}\text{C}$ Accuracy
- Eight General-Purpose I/O Ports (GPIOs)
- Low-Power SPI-Compatible Serial Interface
 - 4-Wire Mode, 1.8 V to 5.5 V Operation
- Operating Temperature: -40°C to $+125^{\circ}\text{C}$
- Available in 64-Pin HTQFP PowerPAD™ IC Package

2 Applications

- Communications Infrastructure:
 - Cellular Base Stations
 - Microwave Backhaul
 - Optical Networks
- General-Purpose Monitor and Control
- Data Acquisition Systems

3 Description

The AMC7836 is a highly-integrated, low-power, analog monitoring and control solution. The device includes a 21-channel, 12-bit analog-to-digital converter (ADC), sixteen 12-bit digital-to-analog converters (DACs) with programmable output ranges, eight GPIOs, an internal reference, and a local temperature-sensor channel. The high level of integration significantly reduces component count and simplifies closed-loop system designs making it ideal for multichannel applications where board space, size, and low-power are critical.

The low-power, very high-integration and wide operating-temperature range of the device make it suitable as an all-in-one, low-cost, bias-control circuit for the power amplifiers (PA) found in multichannel RF communication systems. The flexible DAC output ranges allow the device to be used as a biasing solution for a large variety of transistor technologies, such as LDMOS, GaAs, and GaN. The AMC7836 feature set is similarly beneficial in general-purpose monitor and control systems.

For applications that require a different channel-count, additional features, or converter resolutions, Texas Instruments offers a complete family of analog monitor and control (AMC) products. For more information, go to www.ti.com/amc.

Device Information⁽¹⁾

PART NUMBER	PACKAGE	BODY SIZE (NOM)
AMC7836	HTQFP (64)	10.00 mm x 10.00 mm

(1) For all available packages, see the orderable addendum at the end of the datasheet.

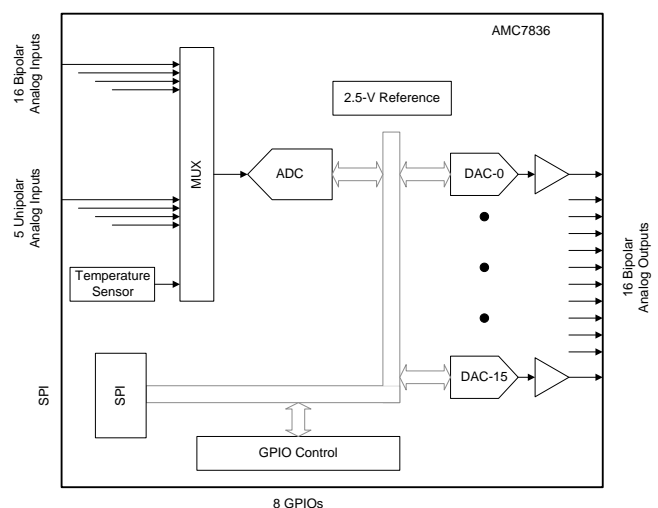

Table of Contents

1 Features	1	7.2 Functional Block Diagram	24
2 Applications	1	7.3 Feature Description	25
3 Description	1	7.4 Device Functional Modes	39
4 Revision History	2	7.5 Programming	42
5 Pin Configuration and Functions	3	7.6 Register Maps	44
6 Specifications	6	8 Application and Implementation	71
6.1 Absolute Maximum Ratings	6	8.1 Application Information	71
6.2 ESD Ratings	6	8.2 Typical Application	74
6.3 Recommended Operating Conditions	7	9 Power Supply Recommendations	77
6.4 Thermal Information	7	9.1 Device Reset Options	78
6.5 Electrical Characteristics: DAC	8	10 Layout	78
6.6 Electrical Characteristics: ADC and Temperature Sensor	10	10.1 Layout Guidelines	78
6.7 Electrical Characteristics: General	11	10.2 Layout Example	79
6.8 Timing Requirements	12	11 Device and Documentation Support	80
6.9 Typical Characteristics: DAC	14	11.1 Documentation Support	80
6.10 Typical Characteristics: ADC	20	11.2 Community Resources	80
6.11 Typical Characteristics: Reference	22	11.3 Trademarks	80
6.12 Typical Characteristics: Temperature Sensor	22	11.4 Electrostatic Discharge Caution	80
7 Detailed Description	23	11.5 Glossary	80
7.1 Overview	23	12 Mechanical, Packaging, and Orderable Information	80

4 Revision History

NOTE: Page numbers for previous revisions may differ from page numbers in the current version.

Changes from Revision B (February 2015) to Revision C	Page
• Changed Figure 117; corrected pins 63 and 64	74

Changes from Revision A (November 2014) to Revision B	Page
• Changed device status from <i>Product Preview</i> to <i>Production Data</i>	1

5 Pin Configuration and Functions

PAP Package
64-Pin HTQFP With Exposed Thermal Pad
Top View

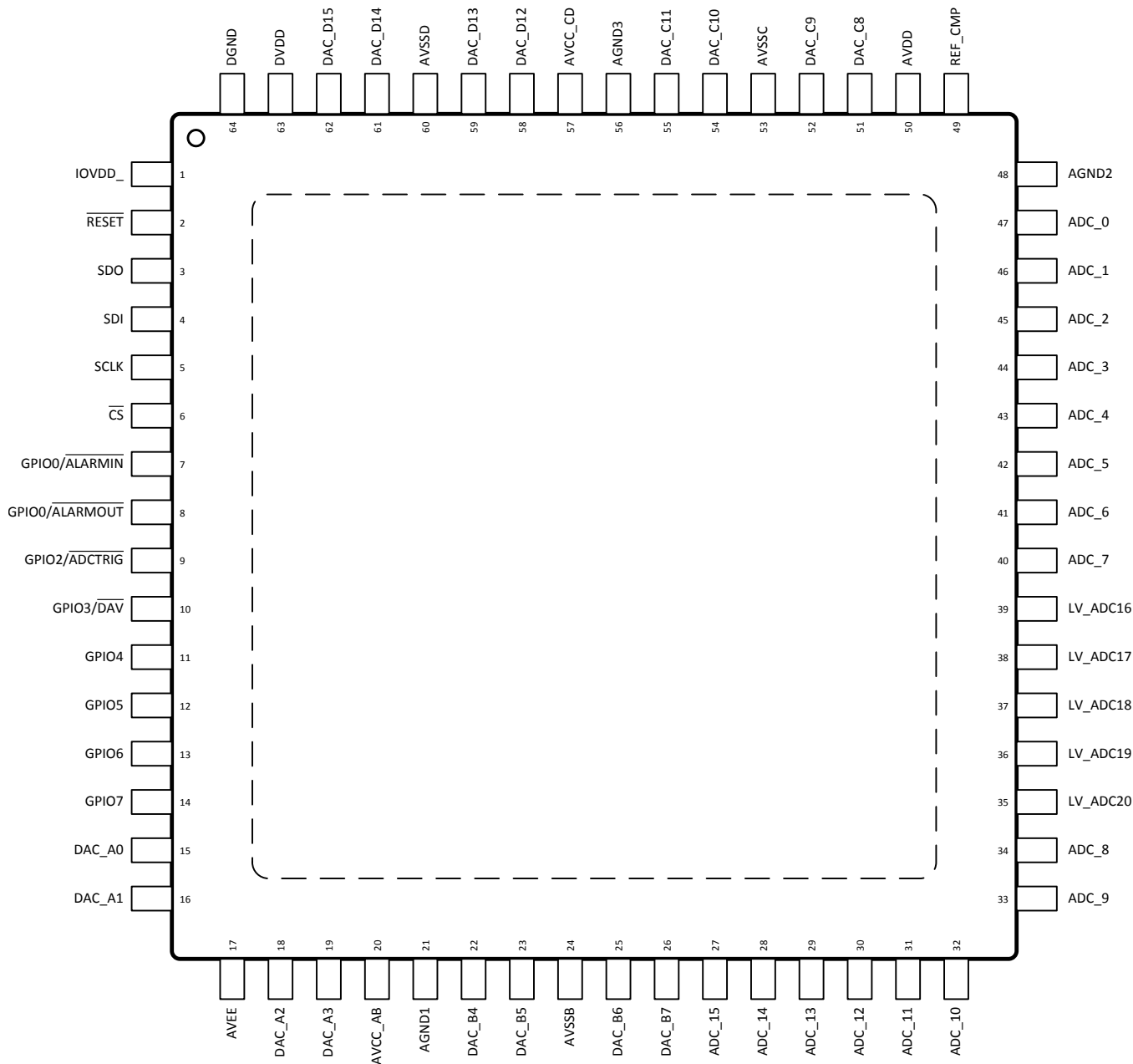

Pin Functions

PIN			DESCRIPTION
NAME	NO.	I/O	
ADC_0	47	I	Bipolar analog inputs. These pins are typically used to monitor the DAC group-C outputs. The input range of these channels is –12.5 to 12.5 V.
ADC_1	46	I	
ADC_2	45	I	
ADC_3	44	I	
ADC_4	43	I	Bipolar analog inputs. These pins are typically used to monitor the DAC group-D outputs. The input range of these channels is –12.5 to 12.5 V.
ADC_5	42	I	
ADC_6	41	I	
ADC_7	40	I	
ADC_8	34	I	Bipolar analog inputs. These pins are typically used to monitor the DAC group-B outputs. The input range of these channels is –12.5 to 12.5 V.
ADC_9	33	I	
ADC_10	32	I	
ADC_11	31	I	
ADC_12	30	I	Bipolar analog inputs. These pins are typically used to monitor the DAC group-A outputs. The input range of these channels is –12.5 to 12.5 V.
ADC_13	29	I	
ADC_14	28	I	
ADC_15	27	I	
AGND1	21	I	Analog ground. These pins are the ground reference point for all analog circuitry on the device. Connect the AGND1, AGND2, and AGND3 pins to the same potential (AGND). Ideally, the analog and digital grounds should be at the same potential (GND) and must not differ by more than ± 0.3 V.
AGND2	48	I	
AGND3	56	I	
AV _{CC_AB}	20	I	Positive analog power for DAC groups A and B. The AV _{CC_AB} and AV _{CC_CD} pins must be connected to the same potential (AV _{CC}).
AV _{CC_CD}	57	I	Positive analog power for DAC groups C and D. The AV _{CC_AB} and AV _{CC_CD} pins must be connected to the same potential (AV _{CC}).
AV _{DD}	50	I	Analog supply voltage (4.5 V to 5.5 V). This pin must have the same value as the DV _{DD} pin.
AV _{EE}	17	I	Lowest potential in the system. This pin is typically tied to a negative supply voltage but if all DACs are set in a positive output range, this pin can be connected to the analog ground. This pin also acts as the negative analog supply for DAC group A. This pin sets the power-on-reset and clamp voltage values for the DAC group A.
AV _{SSB}	24	I	Negative analog supply for DAC group B. This pin sets the power-on-reset and clamp voltage values for the DAC group B. This pin is typically tied to the AV _{EE} pin for the negative output ranges or AGND for the positive output ranges.
AV _{SSC}	53	I	Negative analog supply for DAC group C. This pin sets the power-on-reset and clamp voltage values for the DAC group C. This pin is typically tied to the AV _{EE} pin for the negative output ranges or AGND for the positive output ranges.
AV _{SSD}	60	I	Negative analog supply for DAC group D. This pin sets the power-on-reset and clamp voltage values for the DAC group D. This pin is typically tied to the AV _{EE} pin for the negative output ranges or AGND for the positive output ranges.
$\overline{\text{CS}}$	6	I	Active-low serial-data enable. This input is the frame-synchronization signal for the serial data. When this signal goes low, it enables the serial interface input shift register.
DAC_A0	15	O	DAC group A. These DAC channels share the same range and clamp voltage. If any of the other DAC groups is in a negative voltage range, DAC group A should be in a negative voltage range as well.
DAC_A1	16	O	
DAC_A2	18	O	
DAC_A3	19	O	
DAC_B4	22	O	DAC group B. These DAC channels share the same range and clamp voltage.
DAC_B5	23	O	
DAC_B6	25	O	
DAC_B7	26	O	

Pin Functions (continued)

PIN			DESCRIPTION
NAME	NO.	I/O	
DAC_C8	51	O	DAC group C. These DAC channels share the same range and clamp voltage.
DAC_C9	52	O	
DAC_C10	54	O	
DAC_C11	55	O	
DAC_D12	58	O	
DAC_D13	59	O	DAC group D. These DAC channels share the same range and clamp voltage.
DAC_D14	61	O	
DAC_D15	62	O	
DGND	64	I	
DV _{DD}	63	I	Digital supply voltage (4.5 V to 5.5 V). This pin must have the same value as the AV _{DD} pin.
GPIO0/ $\overline{\text{ALARMIN}}$	7	I/O	General-purpose digital I/O 0 (default). This pin is a bidirectional digital input/output (I/O) with an internal 48-k Ω pullup resistor to the IOV _{DD} pin. Alternatively the pin can be set to operate as the digital input $\overline{\text{ALARMIN}}$ which is an active-low alarm-control signal. If unused this pin can be left floating.
GPIO0/ $\overline{\text{ALARMOUT}}$	8	I/O	General purpose digital I/O 1 (default). This pin is a bidirectional digital I/O with an internal 48-k Ω pullup resistor to the IOV _{DD} pin. Alternatively the pin can be set to operate as $\overline{\text{ALARMOUT}}$ which is an open drain global alarm output. This pin goes low (active) when an alarm event is detected. If unused this pin can be left floating.
GPIO2/ $\overline{\text{ADCTRIG}}$	9	I/O	General purpose digital I/O 2 (default). This pin is a bidirectional digital I/O with internal 48-k Ω pullup resistor to the IOV _{DD} pin. Alternatively the pin can be set to operate as $\overline{\text{ADCTRIG}}$ which is an active-low external conversion trigger. The falling edge of this pin begins the sampling and conversion of the ADC. If unused this pin can be left floating.
GPIO3/ $\overline{\text{DAV}}$	10	I/O	General purpose digital I/O 3 (default). This pin is a bidirectional digital I/O with internal 48-k Ω pullup resistor to the IOV _{DD} pin. Alternatively the pin can be set to operate as $\overline{\text{DAV}}$ which is an active-low data-available indicator output. In direct mode, the $\overline{\text{DAV}}$ pin goes low (active) when the conversion ends. In auto mode, a 1- μ s pulse (active low) appears on this pin when a conversion cycle finishes. The $\overline{\text{DAV}}$ pin remains high when deactivated. If unused this pin can be left floating.
GPIO4	11	I/O	General purpose digital I/O. These pins are bidirectional digital I/Os with an internal 48-k Ω pullup resistor to the IOV _{DD} pin. If unused these pins can be left floating.
GPIO5	12	I/O	
GPIO6	13	I/O	
GPIO7	14	I/O	
IOV _{DD}	1	I	I/O supply voltage (1.8 V to 5.5 V). This pin sets the I/O operating voltage and threshold levels. The voltage on this pin must not be greater than the value of the DV _{DD} pin.
LV_ADC16	39	I	General purpose analog inputs. These channels are used for general monitoring. The input range of these pins is 0 to $2 \times V_{\text{ref}}$.
LV_ADC17	38	I	
LV_ADC18	37	I	
LV_ADC19	36	I	
LV_ADC20	35	I	
REF_CMP	49	O	Internal-reference compensation-capacitor connection. Connect a 4.7- μ F capacitor between this pin and the AGND2 pin.
$\overline{\text{RESET}}$	2	I	Active-low reset input. Logic low on this pin causes the device to perform a hardware reset.
SCLK	5	I	Serial interface clock.
SDI	4	I	Serial-interface data input. Data is clocked into the input shift register on each rising edge of the SCLK pin.
SDO	3	O	Serial-interface data output. The SDO pin is in high impedance when the $\overline{\text{CS}}$ pin is high. Data is clocked out of the input shift register on each falling edge of the SCLK pin.
Thermal Pad	—	I	The thermal pad is located on the bottom-side of the device package. The thermal pad should be tied to the same potential as the AV _{EE} pin or left disconnected.

6 Specifications

6.1 Absolute Maximum Ratings

 over operating free-air temperature range (unless otherwise noted) ⁽¹⁾

		MIN	MAX	UNIT
Supply Voltage	AV _{DD} to GND	-0.3	6	V
	DV _{DD} to GND	-0.3	6	
	IOV _{DD} to GND	-0.3	6	
	AV _{CC} to GND	-0.3	18	
	AV _{EE} to GND	-13	0.3	
	AV _{SSB} , AV _{SSC} , AV _{SSD} to AV _{EE}	-0.3	13	
	AV _{CC} to AV _{SSB} , AV _{SSC} , or AV _{SSD}	-0.3	26	
	AV _{CC} to AV _{EE}	-0.3	26	
	DGND to AGND	-0.3	0.3	
Pin Voltage	ADC_[0-15] analog input voltage to GND	-13	13	V
	LV_ADC[16-20] analog input voltage to GND	-0.3	AV _{DD} + 0.3	
	DAC_A[0-3] outputs to GND	AV _{EE} - 0.3	AV _{CC} + 0.3	
	DAC_B[4-7] outputs to GND	AV _{SSB} - 0.3	AV _{CC} + 0.3	
	DAC_C[8-11] outputs to GND	AV _{SSC} - 0.3	AV _{CC} + 0.3	
	DAC_D[12-15] outputs to GND	AV _{SSD} - 0.3	AV _{CC} + 0.3	
	REF_CMP to GND	-0.3	AV _{DD} + 0.3	
	$\overline{\text{CS}}$, SCLK, SDI and $\overline{\text{RESET}}$ to GND	-0.3	IOV _{DD} + 0.3	
	SDO to GND	-0.3	IOV _{DD} + 0.3	
	GPIO[0-7] to GND	-0.3	IOV _{DD} + 0.3	
Pin Current	ADC_[0:15] analog input current	-10	10	mA
	LV_ADC[16:20] analog input current	-10	10	
	GPIO[0:7] sinking current		5	
Operating temperature		-40	125	°C
Junction temperature, T _{Jmax}		-40	150	°C
Storage temperature, T _{stg}		-40	150	°C

(1) Stresses beyond those listed under *Absolute Maximum Ratings* may cause permanent damage to the device. These are stress ratings only, which do not imply functional operation of the device at these or any other conditions beyond those indicated under *Recommended Operating Conditions*. Exposure to absolute-maximum-rated conditions for extended periods may affect device reliability.

6.2 ESD Ratings

			VALUE	UNIT
V _(ESD)	Electrostatic discharge	Human body model (HBM), per ANSI/ESDA/JEDEC JS-001 ⁽¹⁾	±1000	V
		Charged device model (CDM), per JEDEC specification JESD22-C101 ⁽²⁾	±250	

(1) JEDEC document JEP155 states that 500 V HBM allows safe manufacturing with a standard ESD control process.

(2) JEDEC document JEP157 states that 250 V CDM allows safe manufacturing with a standard ESD control process.

6.3 Recommended Operating Conditions

over operating free-air temperature range (unless otherwise noted)

		MIN	NOM	MAX	UNIT
Supply voltage	AV _{DD}	4.5	5	5.5	V
	DV _{DD} ⁽¹⁾	4.5	5	5.5	
	IOV _{DD} ⁽²⁾	1.8		5.5	
	AV _{CC}	4.5	12	12.5	
	AV _{EE}	-12.5	-12	0	
	AV _{SSB} , AV _{SSC} , AV _{SSD}	AV _{EE}		0	
Specified operating temperature		-40	25	105	°C
Operating temperature		-40	25	125	°C

- (1) The value of the DV_{DD} pin must be equal to that of the AV_{DD} pin.
 (2) The value of the IOV_{DD} pin must be less than or equal to that of the DV_{DD} pin.

6.4 Thermal Information

THERMAL METRIC ⁽¹⁾		PAP (HTQFP)	UNIT
		64 PINS	
R _{θJA}	Junction-to-ambient thermal resistance	26.2	°C/W
R _{θJC(top)}	Junction-to-case (top) thermal resistance	7.2	°C/W
R _{θJB}	Junction-to-board thermal resistance	9.1	°C/W
ψ _{JT}	Junction-to-top characterization parameter	0.2	°C/W
ψ _{JB}	Junction-to-board characterization parameter	9	°C/W
R _{θJC(bot)}	Junction-to-case (bottom) thermal resistance	0.2	°C/W

- (1) For more information about traditional and new thermal metrics, see the *IC Package Thermal Metrics* application report, [SPRA953](#).

6.5 Electrical Characteristics: DAC

The electrical ratings specified in this section apply to all specifications in this document, unless otherwise noted. These specifications are interpreted as conditions that do not degrade the device parametric or functional specifications for the life of the product containing it. $AV_{DD} = DV_{DD} = 4.5$ to 5.5 V, $AV_{CC} = 12$ V, $IOV_{DD} = 1.8$ to 5.5 V, $AGND = DGND = 0$ V, $AV_{EE} = AV_{SSB} = AV_{SSC} = AV_{SSD} = -12$ V (for DAC groups in negative range) or 0 V (for DAC groups in positive ranges), DAC output range = 0 to 10 V for all groups, no load on the DACs, $T_A = -40^{\circ}\text{C}$ to 105°C

PARAMETER		TEST CONDITIONS	MIN	TYP	MAX	UNIT
DAC DC ACCURACY						
	Resolution		12			Bits
INL	Relative accuracy	Measured by line passing through codes 020h and FFFh. 0 to 10 V and -10 to 0 V ranges		± 0.3	± 1	LSB
		Measured by line passing through codes 040h and FFFh. 0 to 5 V and -5 to 0 V ranges		± 0.5	± 1.5	
DNL	Differential nonlinearity	Specified monotonic. Measured by line passing through codes 020h and FFFh. 0 to 10 V and -10 to 0 V ranges		± 0.03	± 1	LSB
		Specified monotonic. Measured by line passing through codes 020h and FFFh. 0 to 5 V and -5 to 0 V ranges		± 0.06	± 1	
TUE	Total unadjusted error ⁽¹⁾	$T_A = 25^{\circ}\text{C}$, 0 to 10 V range		± 2.5	± 20	mV
		$T_A = 25^{\circ}\text{C}$, -10 to 0 V range		± 2.5	± 20	
		$T_A = 25^{\circ}\text{C}$, 0 to 5 V range		± 1.5	± 15	
		$T_A = 25^{\circ}\text{C}$, -5 to 0 V range		± 1.5	± 15	
	Offset error	$T_A = 25^{\circ}\text{C}$, Measured by line passing through codes 020h and FFFh. 0 to 10 V range		± 0.25	± 5	mV
		$T_A = 25^{\circ}\text{C}$, Measured by line passing through codes 040h and FFFh. 0 to 5 V range		± 0.25	± 5	
	Zero-code error	$T_A = 25^{\circ}\text{C}$, Code 000h, -10 to 0 V range		± 1	± 25	mV
		$T_A = 25^{\circ}\text{C}$, Code 000h, -5 to 0 V range		± 1	± 25	
	Gain error ⁽¹⁾	$T_A = 25^{\circ}\text{C}$, Measured by line passing through codes 020h and FFFh, 0 to 10 V range		± 0.01	± 0.2	%FSR
		$T_A = 25^{\circ}\text{C}$, Measured by line passing through codes 020h and FFFh, -10 to 0 V range		± 0.01	± 0.2	
		$T_A = 25^{\circ}\text{C}$, Measured by line passing through codes 040h and FFFh, 0 to 5 V range		± 0.01	± 0.2	
		$T_A = 25^{\circ}\text{C}$, Measured by line passing through codes 040h and FFFh, -5 to 0 V range		± 0.01	± 0.2	
	Offset temperature coefficient	0 to 10 V range		± 1		ppm/ $^{\circ}\text{C}$
		0 to 5 V range		± 1		
	Zero-code temperature coefficient	-10 to 0 V range		± 2		ppm/ $^{\circ}\text{C}$
		-5 to 0 V range		± 2		
	Gain temperature coefficient ⁽¹⁾	0 to 10 V range		± 2.5		ppm/ $^{\circ}\text{C}$
		-10 to 0 V range		± 2.5		
		0 to 5 V range		± 2.5		
		-5 to 0 V range		± 2.5		

(1) The internal reference contribution not included.

Electrical Characteristics: DAC (continued)

The electrical ratings specified in this section apply to all specifications in this document, unless otherwise noted. These specifications are interpreted as conditions that do not degrade the device parametric or functional specifications for the life of the product containing it. $AV_{DD} = DV_{DD} = 4.5$ to 5.5 V, $AV_{CC} = 12$ V, $IOV_{DD} = 1.8$ to 5.5 V, $AGND = DGND = 0$ V, $AV_{EE} = AV_{SSB} = AV_{SSC} = AV_{SSD} = -12$ V (for DAC groups in negative range) or 0 V (for DAC groups in positive ranges), DAC output range = 0 to 10 V for all groups, no load on the DACs, $T_A = -40^{\circ}\text{C}$ to 105°C

PARAMETER	TEST CONDITIONS	MIN	TYP	MAX	UNIT
DAC OUTPUT CHARACTERISTICS					
Full-scale output voltage range ⁽²⁾	Set at power-up or reset through auto-range detection. The output range can be modified after power-up or reset through the DAC range registers (address 0x1E through 0x1F). DAC-RANGE = 100b	-10		0	V
	The output range can be modified after power-up or reset through the DAC range registers (address 0x1E through 0x1F). DAC-RANGE = 101b	-5		0	
	Set at power-up or reset through auto-range detection. The output range can be modified after power-up or reset through the DAC range registers (address 0x1E through 0x1F). DAC-RANGE = 111b	0		5	
	The output range can be modified after power-up or reset through the DAC range registers (address 0x1E through 0x1F). DAC-RANGE = 110b	0		10	
Output voltage settling time	Transition: Code 400h to C00h to within $\frac{1}{2}$ LSB, $R_L = 2$ k Ω , $C_L = 200$ pF. 0 to 10 V and -10 to 0 V ranges		10		μs
	Transition: Code 400h to C00h to within $\frac{1}{2}$ LSB, $R_L = 2$ k Ω , $C_L = 200$ pF. 0 to 5 V and -5 to 0 V ranges		10		
Slew rate	Transition: Code 400h to C00h, 10% to 90%, $R_L = 2$ k Ω , $C_L = 200$ pF. 0 to 10 V and -10 to 0 V ranges		1.25		V/ μs
	Transition: Code 400h to C00h, 10% to 90%, $R_L = 2$ k Ω , $C_L = 200$ pF. 0 to 5 V and -5 to 0 V ranges		1.25		
Short circuit current	Full-scale current shorted to the DAC group AV_{SS} or AV_{CC} voltage		± 45		mA
Load current ⁽³⁾	Source or sink with 1-V headroom from the DAC group AV_{CC} or AV_{SS} voltage, voltage drop < 25 mV	± 15			mA
	Source or sink with 300-mV headroom from the DAC group AV_{CC} or AV_{SS} voltage, voltage drop < 25 mV	± 10			
Maximum capacitive load ⁽⁴⁾	$R_L = \infty$	0		10	nF
DC output impedance	Code set to 800h, ± 15 mA		1		Ω
Power-on overshoot	$AV_{EE} = AV_{SSB} = AV_{SSC} = AV_{SSD} = AGND$, $AV_{CC} = 0$ to 12 V, 2-ms ramp		10		mV
Glitch energy	Transition: Code 7FFh to 800h; 800h to 7FFh		1		nV-s
Output noise	$T_A = 25^{\circ}\text{C}$, 1 kHz, code 800h, includes internal reference noise		520		$\text{nV}/\sqrt{\text{Hz}}$
	$T_A = 25^{\circ}\text{C}$, integrated noise from 0.1 Hz to 10 Hz, code 800h, includes internal reference noise		20		μV_{PP}
CLAMP OUTPUTS					
Clamp output voltage ⁽⁵⁾	DAC output range: 0 to 10 V, $AV_{SS} = AGND$		0		V
	DAC output range: 0 to 5 V, $AV_{SS} = AGND$		0		
	DAC output range: -10 to 0 V, $AV_{SS} = -12$ V		$AV_{SS} + 2$		
	DAC output range: -5 to 0 V, $AV_{SS} = -6$ V		$AV_{SS} + 1$		
Clamp output impedance			8		k Ω

(2) The output voltage of each DAC group must not be greater than that of the corresponding AV_{CC} pin (AV_{CC_AB} or AV_{CC_CD}) or lower than that of the corresponding AV_{SS} pin (AV_{EE} , AV_{SSB} , AV_{SSC} or AV_{SSD}). See the [DAC Output Range and Clamp Configuration](#) section for more details.

(3) If all channels are simultaneously loaded, care must be taken to ensure the thermal conditions for the device are not exceeded.

(4) To be sampled during initial release to ensure compliance; not subject to production testing.

(5) No DAC load to the DAC group AV_{SS} pin.

6.6 Electrical Characteristics: ADC and Temperature Sensor

The electrical ratings specified in this section apply to all specifications in this document, unless otherwise noted. These specifications are interpreted as conditions that do not degrade the device parametric or functional specifications for the life of the product containing it. $AV_{DD} = DV_{DD} = 4.5$ to 5.5 V, $AV_{CC} = 12$ V, $IOV_{DD} = 1.8$ to 5.5 V, $AGND = DGND = 0$ V, $AV_{EE} = AV_{SSB} = AV_{SSC} = AV_{SSD} = -12$ V (for DAC groups in negative range) or 0 V (for DAC groups in positive ranges), DAC output range = 0 to 10 V for all groups, no load on the DACs, $T_A = -40^{\circ}\text{C}$ to 105°C

PARAMETER	TEST CONDITIONS	MIN	TYP	MAX	UNIT
Resolution		12			Bits
Integral nonlinearity	Unipolar input channels		± 0.5	± 1	LSB
	Bipolar input channels		± 0.5	± 1.5	
Differential nonlinearity	Specified monotonic. All input channels		± 0.5	± 1	LSB
UNIPOLAR ANALOG INPUTS: LV_ADC16 to LV_ADC20					
Absolute input voltage range		$AGND - 0.2$		$AV_{DD} + 0.2$	V
Full scale input range	V_{ref} measured at REF_CMP pin	0		$2 \times V_{ref}$	V
Input capacitance			34		pF
DC input leakage current	Unselected ADC input			± 10	μA
Offset error			± 1	± 5	LSB
Offset error match			± 0.5		LSB
Gain error ⁽¹⁾			± 0.5	± 5	LSB
Gain error match			± 1		LSB
Update time	Single unipolar input, temperature sensor disabled		11.5		μs
BIPOLAR ANALOG INPUTS: ADC_0 to ADC_15					
Absolute input voltage range		-13		13	V
Full scale input range		-12.5		12.5	V
Input resistance			175		k Ω
Offset error			± 0.25	± 5	LSB
Gain error ⁽¹⁾			± 0.5	± 5	LSB
Update time	Single bipolar input, temperature sensor disabled		34.5		μs
TEMPERATURE SENSOR					
Operating range		-40		125	$^{\circ}\text{C}$
Accuracy	$T_A = -40^{\circ}\text{C}$ to 125°C , $AV_{DD} = 5$ V		± 1.25	± 2.5	$^{\circ}\text{C}$
Resolution	LSB size		0.25		$^{\circ}\text{C}$
Update time	All ADC input channels disabled		256		μs
ADC UPDATE TIME					
Internal oscillator frequency		3.7	4	4.3	MHz
ADC update time	All 21 ADC inputs enabled, temperature sensor disabled.		609.5		μs
	All 21 ADC inputs enabled, temperature sensor enabled.		865.5		μs
INTERNAL REFERENCE (INTERNAL REFERENCE NOT ACCESSIBLE)					
Initial accuracy	$T_A = 25^{\circ}\text{C}$	2.4925	2.5	2.5075	V
Reference temperature coefficient			12	35	ppm/ $^{\circ}\text{C}$
INTERNAL ADC REFERENCE BUFFER					
Reference buffer offset	$T_A = 25^{\circ}\text{C}$			± 5	mV

(1) Internal reference contribution not included.

6.7 Electrical Characteristics: General

The electrical ratings specified in this section apply to all specifications in this document, unless otherwise noted. These specifications are interpreted as conditions that do not degrade the device parametric or functional specifications for the life of the product containing it. $AV_{DD} = DV_{DD} = 4.5$ to 5.5 V, $AV_{CC} = 12$ V, $IOV_{VDD} = 1.8$ to 5.5 V, $AGND = DGND = 0$ V, $AV_{EE} = AV_{SSB} = AV_{SSC} = AV_{SSD} = -12$ V (for DAC groups in negative range) or 0 V (for DAC groups in positive ranges), DAC output range = 0 to 10 V for all groups, no load on the DACs, $T_A = -40^{\circ}\text{C}$ to 105°C

PARAMETER	TEST CONDITIONS	MIN	TYP	MAX	UNIT
AV_{SS} DETECTOR					
AV _{SS} threshold detector (AV _{SS} STH)		-3.5		-1.5	V
DIGITAL LOGIC: GPIO					
High-level input voltage	IOV _{DD} = 1.8 to 5.5 V	0.7 × IOV _{DD}			V
Low-level input voltage	IOV _{DD} = 1.8 V			0.45	V
	IOV _{DD} = 2.7 to 5.5 V			0.3 × IOV _{DD}	
Low-level output voltage	IOV _{DD} = 1.8 V, I _(LOAD) = -2 mA			0.4	V
	IOV _{DD} = 5.5 V, I _(LOAD) = -5 mA			0.4	
Input impedance	To IOV _{DD}	48			kΩ
DIGITAL LOGIC: ALL EXCEPT GPIO					
High-level input voltage	IOV _{DD} = 1.8 to 5.5 V	0.7 × IOV _{DD}			V
Low-level input voltage	IOV _{DD} = 1.8 V			0.45	V
	IOV _{DD} = 2.7 to 5.5 V			0.3 × IOV _{DD}	V
High-level output voltage	I _(LOAD) = -1 mA	IOV _{DD} - 0.4			V
Low-level output voltage	I _(LOAD) = 1 mA			0.4	V
High impedance leakage				±5	μA
High impedance output capacitance		10			pF
POWER REQUIREMENTS					
I _{AVDD}	AV _{DD} supply current	No DAC load, all DACs at 800h code and ADC at the fastest auto conversion rate	6	13.5	mA
I _{AVCC}	AV _{CC} supply current		7.5	13.5	
I _{AVSS}	AV _{SS} supply current		-13.5	-5	
I _{AVEE}	AV _{EE} supply current		-3.5	-1.75	
I _{DVDD}	DV _{DD} supply current		1	3	
I _{IOVDD}	IOV _{DD} supply current		1.5	15	μA
	Power consumption		215		mW
I _{AVDD}	AV _{DD} supply current	Power-down mode	2.5	5	mA
I _{AVCC}	AV _{CC} supply current		1	2.5	
I _{AVSS}	AV _{SS} supply current		-5	-3	
I _{AVEE}	AV _{EE} supply current		-3	-1.75	
I _{DVDD}	DV _{DD} supply current		0.75	1.5	
I _{IOVDD}	IOV _{DD} supply current		1.5	15	μA
	Power consumption		90		mW

6.8 Timing Requirements

$AV_{DD} = DV_{DD} = 4.5$ to 5.5 V, $AV_{CC} = 12$ V, $AV_{EE} = -12$ V, $AGND = DGND = AV_{SSB} = AV_{SSC} = AV_{SSD} = 0$ V, DAC output range = 0 to 10 V for all groups, no load on the DACs, $T_A = -40^\circ\text{C}$ to 105°C (unless otherwise noted)

		MIN	NOM	MAX	UNIT
SERIAL INTERFACE⁽¹⁾					
$f_{(SCLK)}$	SCLK frequency	$IOV_{DD} = 1.8$ to 2.7 V		15	MHz
		$IOV_{DD} = 2.7$ to 5.5 V		20	
t_p	SCLK period ⁽²⁾	$IOV_{DD} = 1.8$ to 2.7 V	66.67		ns
		$IOV_{DD} = 2.7$ to 5.5 V	50		
t_{PH}	SCLK pulse width high ⁽²⁾	$IOV_{DD} = 1.8$ to 2.7 V	30		ns
		$IOV_{DD} = 2.7$ to 5.5 V	23		
t_{PL}	SCLK pulse width low ⁽²⁾	$IOV_{DD} = 1.8$ to 2.7 V	30		ns
		$IOV_{DD} = 2.7$ to 5.5 V	23		
t_{su}	SDI setup ⁽²⁾	$IOV_{DD} = 1.8$ to 2.7 V	10		ns
		$IOV_{DD} = 2.7$ to 5.5 V	10		
t_h	SDI hold ⁽²⁾	$IOV_{DD} = 1.8$ to 2.7 V	10		ns
		$IOV_{DD} = 2.7$ to 5.5 V	10		
$t_{(ODZ)}$	SDO driven to tri-state ⁽³⁾⁽⁴⁾	$IOV_{DD} = 1.8$ to 2.7 V	0	15	ns
		$IOV_{DD} = 2.7$ to 5.5 V	0	9	
$t_{(OZD)}$	SDO tri-state to driven ⁽³⁾⁽⁴⁾	$IOV_{DD} = 1.8$ to 2.7 V	0	23	ns
		$IOV_{DD} = 2.7$ to 5.5 V	0	15	
$t_{(OD)}$	SDO output delay ⁽³⁾⁽⁴⁾	$IOV_{DD} = 1.8$ to 2.7 V	0	23	ns
		$IOV_{DD} = 2.7$ to 5.5 V	0	15	
$t_{su}(\overline{CS})$	\overline{CS} setup ⁽²⁾	$IOV_{DD} = 1.8$ to 2.7 V	5		ns
		$IOV_{DD} = 2.7$ to 5.5 V	5		
$t_h(\overline{CS})$	\overline{CS} hold ⁽²⁾	$IOV_{DD} = 1.8$ to 2.7 V	20		ns
		$IOV_{DD} = 2.7$ to 5.5 V	20		
$t_{(IAG)}$	Inter-access gap ⁽²⁾	$IOV_{DD} = 1.8$ to 2.7 V	10		ns
		$IOV_{DD} = 2.7$ to 5.5 V	10		
DIGITAL LOGIC					
Reset delay; delay-to-normal operation from reset			100	250	μs
Power-down recovery time				70	μs
Clamp shutdown delay			100		μs
Convert pulse width		20			ns
Reset pulse width		20			ns
ADC WAIT state ⁽⁵⁾ ; the wait time from when the ADC enters the IDLE state to when the ADC is ready for trigger		2			μs

(1) Specified by design and characterization. Not tested during production.

(2) See [Figure 1](#) and [Figure 2](#).

(3) SDO loaded with 10 pF load capacitance for SDO timing specifications.

(4) See [Figure 2](#).

(5) Specified by design; not subject to production testing. See the [ADC Sequencing](#) section for more details.

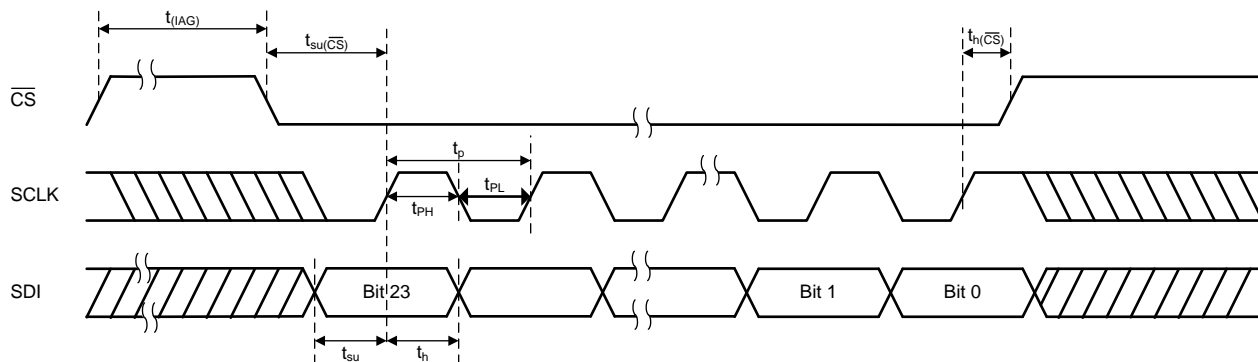

Figure 1. Serial Interface Write Timing Diagram

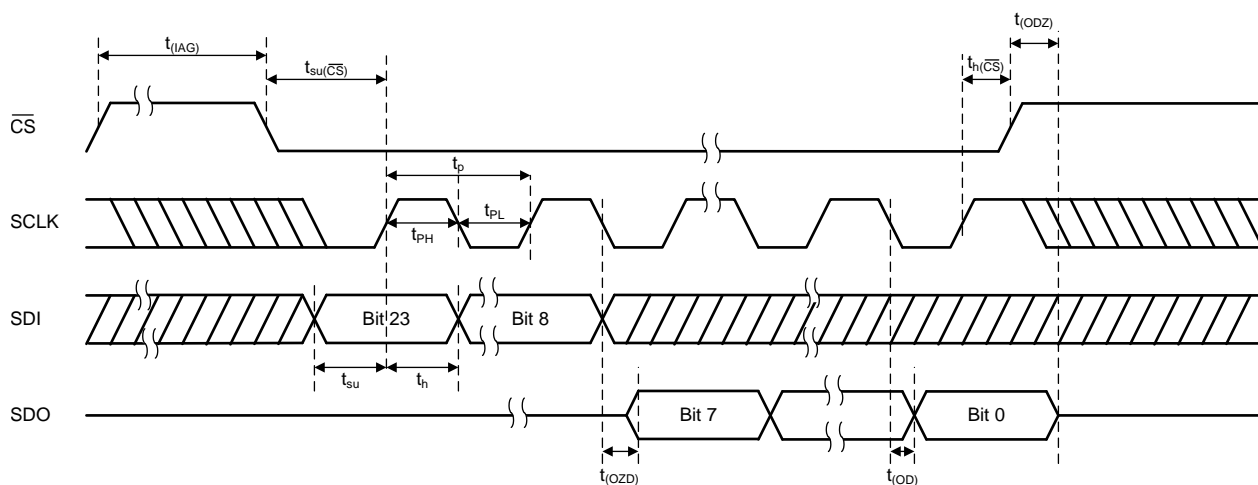

Figure 2. Serial Interface Read Timing Diagram

6.9 Typical Characteristics: DAC

At $T_A = 25^\circ\text{C}$ (unless otherwise noted)

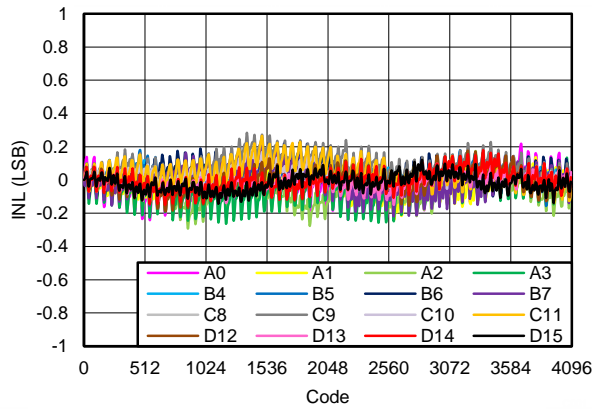

Figure 3. DAC Linearity Error vs Code
DAC Range: 0 to 10 V

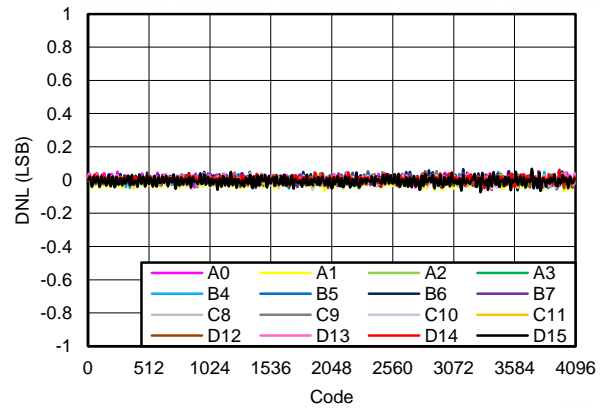

Figure 4. DAC Differential Linearity Error vs Code
DAC Range: 0 to 10 V

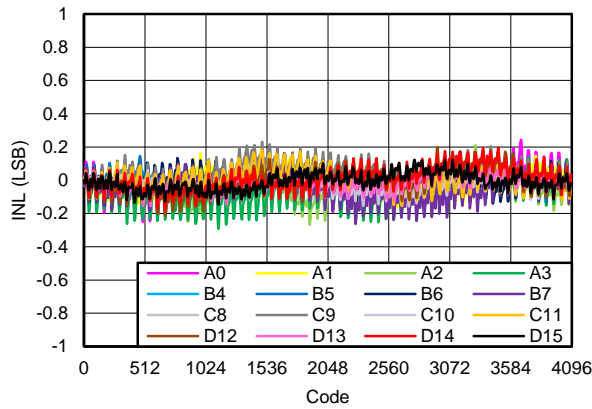

Figure 5. DAC Linearity Error vs Code
DAC Range: -10 to 0 V

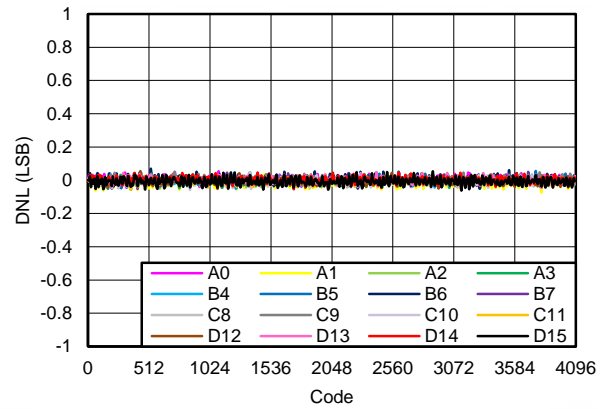

Figure 6. DAC Differential Linearity Error vs Code
DAC Range: -10 to 0 V

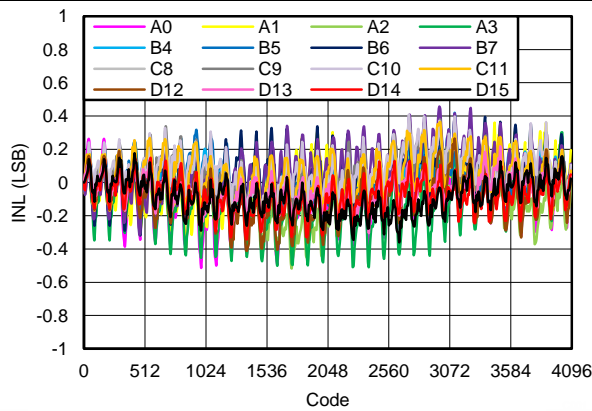

Figure 7. DAC Linearity Error vs Code
DAC Range: 0 to 5 V

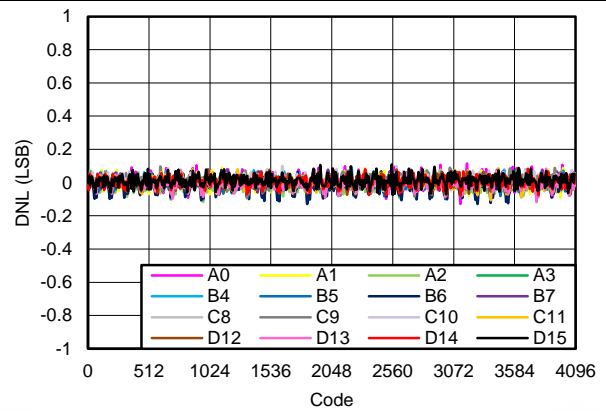

Figure 8. DAC Differential Linearity Error vs Code
DAC Range: 0 to 5 V

Typical Characteristics: DAC (continued)

At $T_A = 25^\circ\text{C}$ (unless otherwise noted)

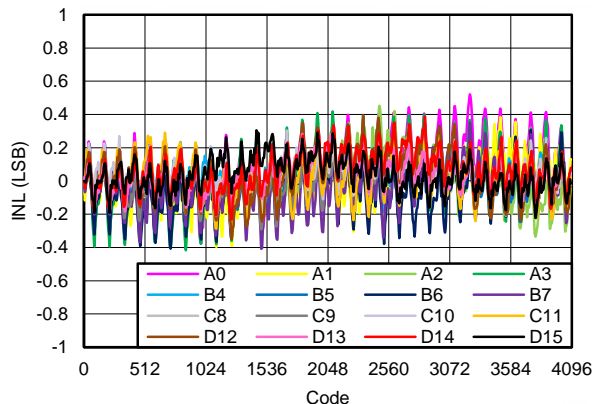

Figure 9. DAC Linearity Error vs Code
DAC Range: -5 to 0 V

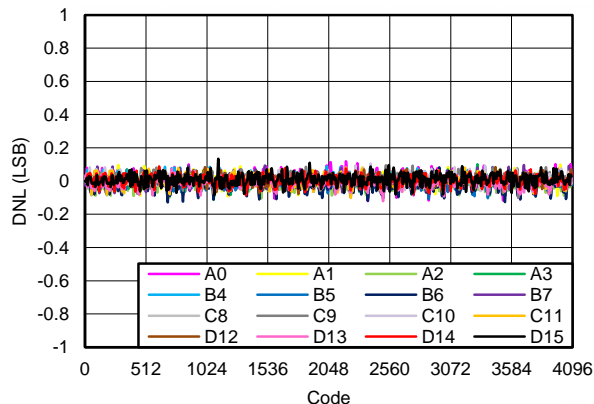

Figure 10. DAC Differential Linearity Error vs Code
DAC Range: -5 to 0 V

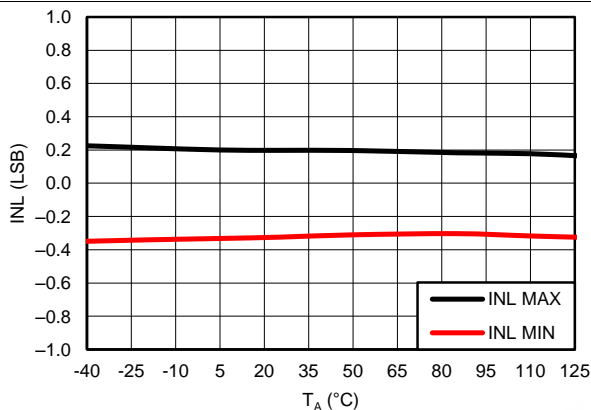

Figure 11. DAC Linearity Error vs Temperature
DAC Range: 0 to 10 V

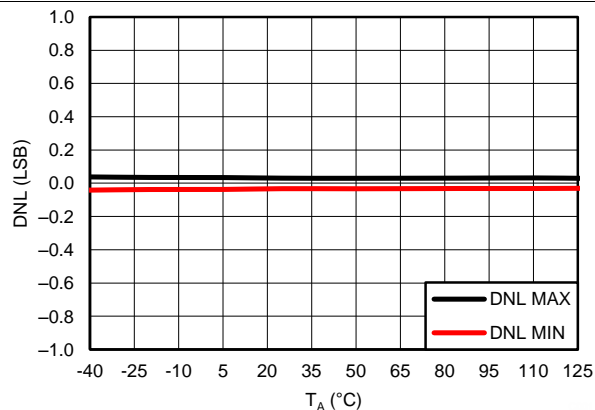

Figure 12. DAC Differential Linearity Error vs Temperature
DAC Range: 0 to 10 V

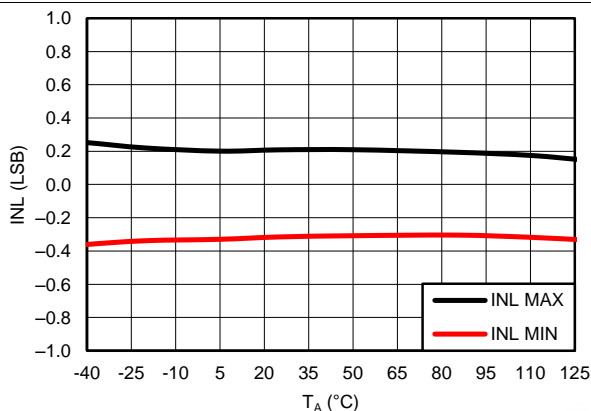

Figure 13. DAC Linearity Error vs Temperature
DAC Range: -10 to 0 V

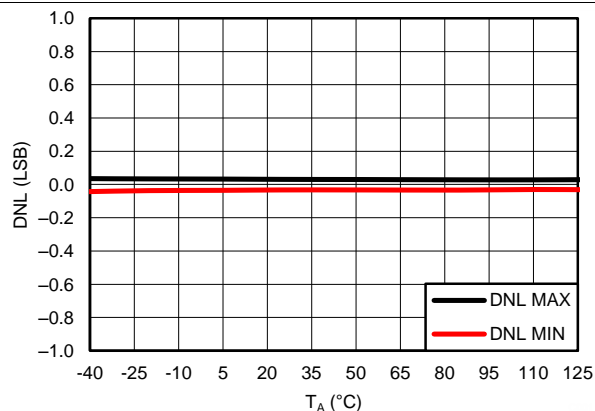

Figure 14. DAC Differential Linearity Error vs Temperature
DAC Range: -10 to 0 V

Typical Characteristics: DAC (continued)

At $T_A = 25^\circ\text{C}$ (unless otherwise noted)

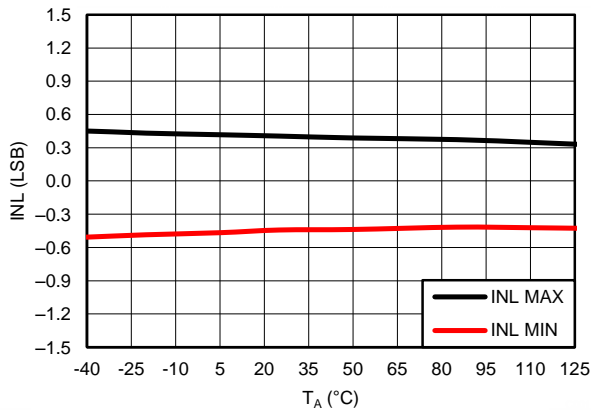

Figure 15. DAC Linearity Error vs Temperature
DAC Range: 0 to 5 V

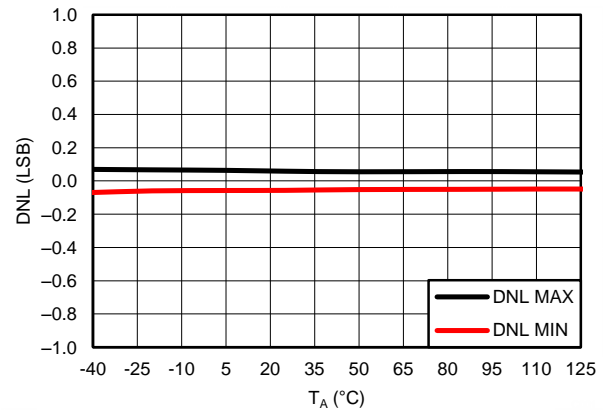

Figure 16. DAC Differential Linearity Error vs Temperature
DAC Range: 0 to 5 V

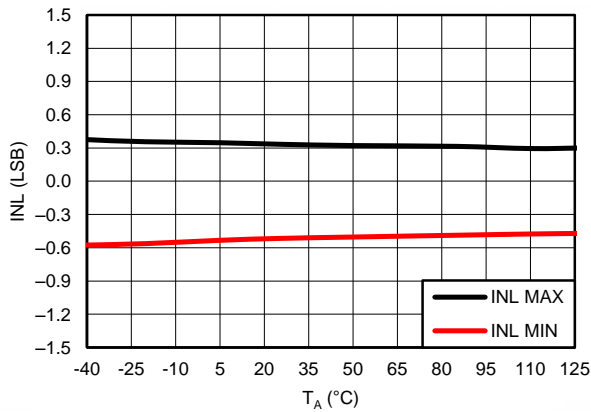

Figure 17. DAC Linearity Error vs Temperature
DAC Range: -5 to 0 V

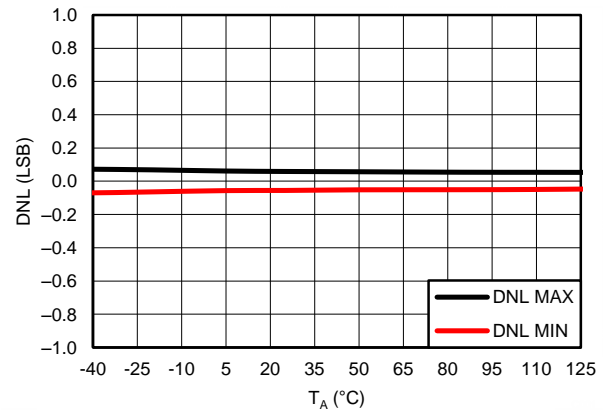

Figure 18. DAC Differential Linearity Error vs Temperature
DAC Range: -5 to 0 V

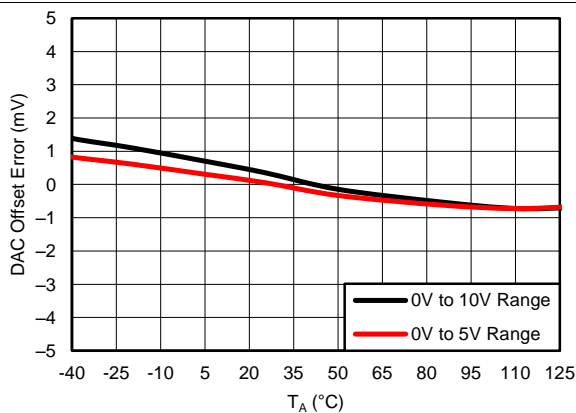

Figure 19. DAC Offset Error vs Temperature

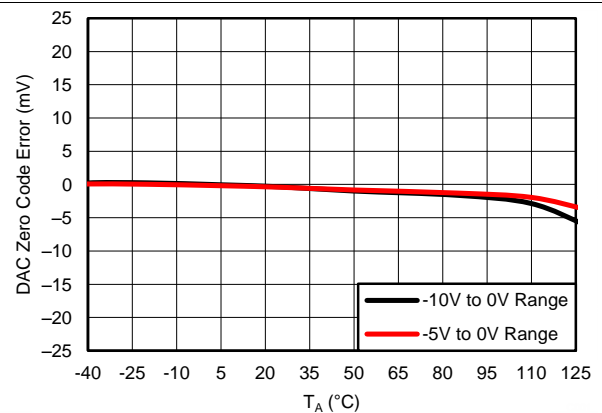

Figure 20. DAC Zero Code Error vs Temperature

Typical Characteristics: DAC (continued)

At $T_A = 25^\circ\text{C}$ (unless otherwise noted)

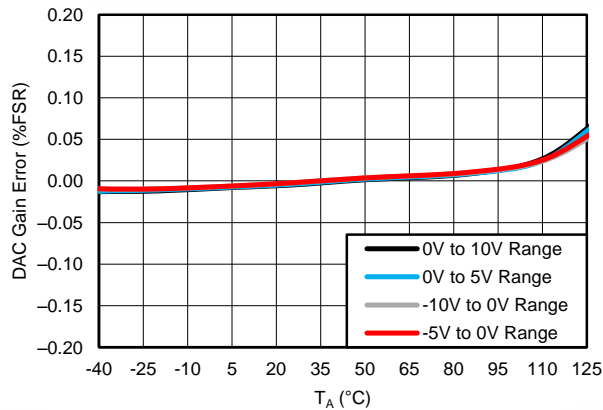
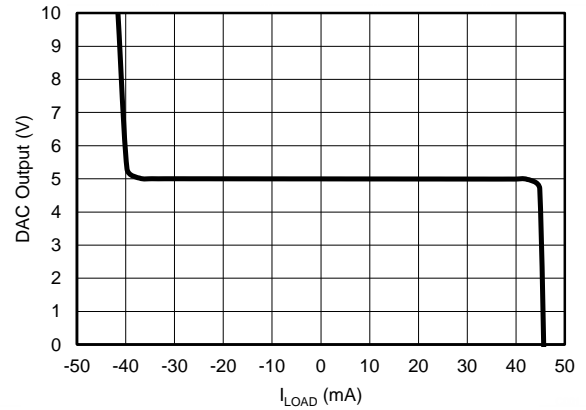
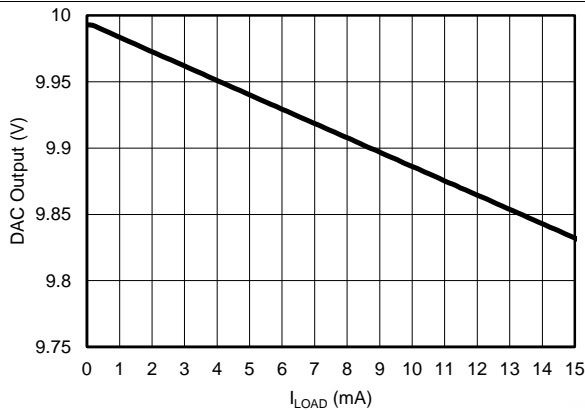

Figure 21. DAC Gain Error vs Temperature



Code 0x800, DAC range: 0 to 10 V

Figure 22. DAC Output Voltage vs Load Current



Code 0xFFFF, DAC range: 0 to 10 V, $AV_{CC} = 10\text{ V}$, $AV_{EE} = 0\text{ V}$

Figure 23. DAC Source Current

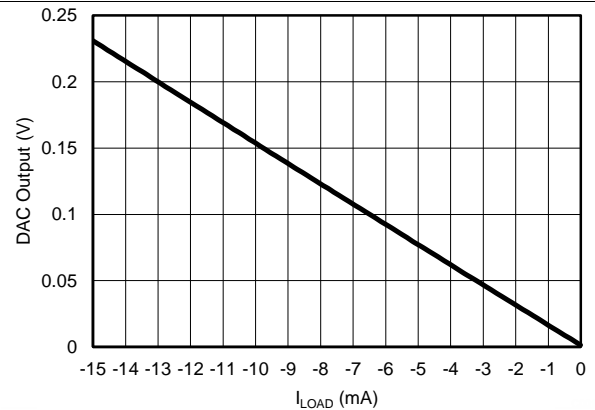

Code 0x000, DAC range: 0 to 10 V, $AV_{CC} = 10\text{ V}$, $AV_{EE} = 0\text{ V}$

Figure 24. DAC Sink Current

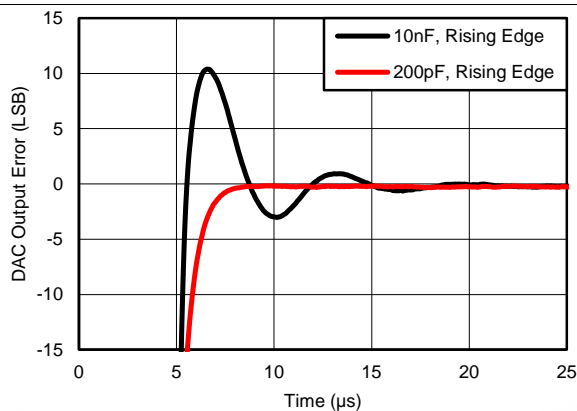

Code 0x400 to 0xC00 to within $\frac{1}{2}$ LSB

Figure 25. DAC Settling Time vs Load Capacitance

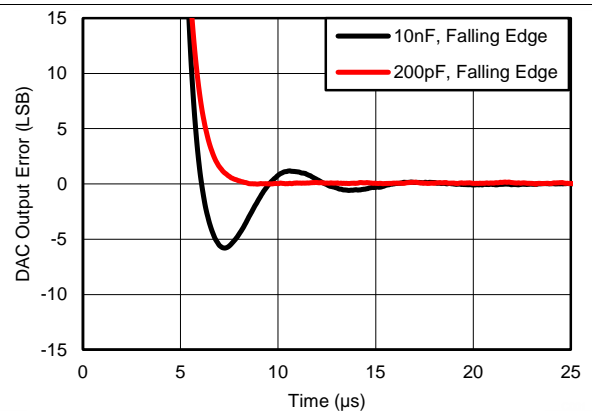

Code 0xC00 to 0x400 to within $\frac{1}{2}$ LSB

Figure 26. DAC Settling Time vs Load Capacitance

Typical Characteristics: DAC (continued)

At $T_A = 25^\circ\text{C}$ (unless otherwise noted)

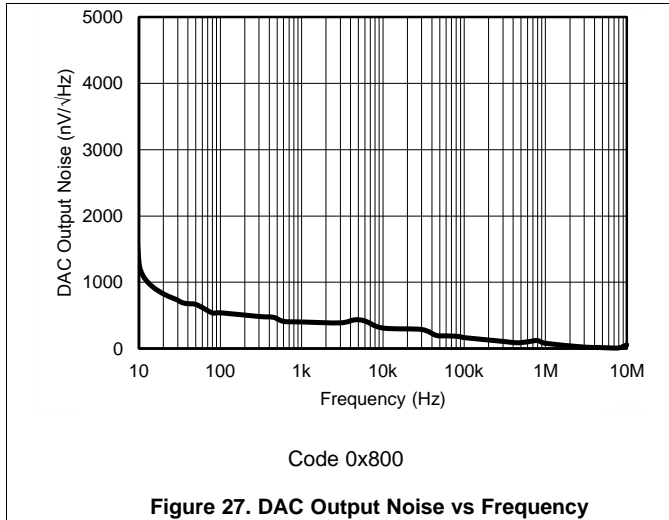

Figure 27. DAC Output Noise vs Frequency

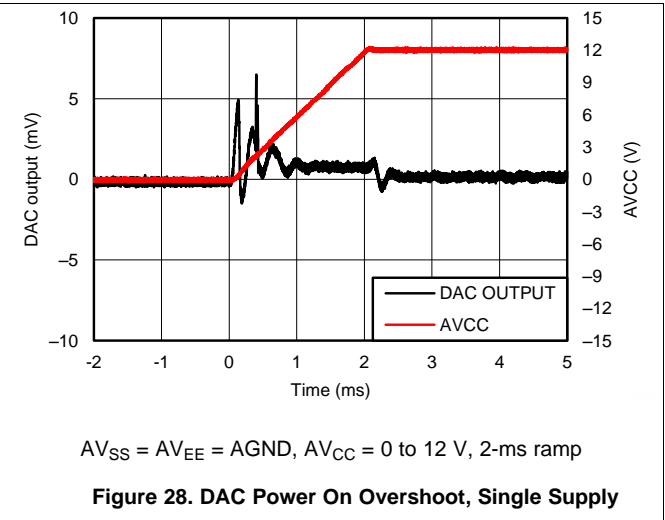

Figure 28. DAC Power On Overshoot, Single Supply

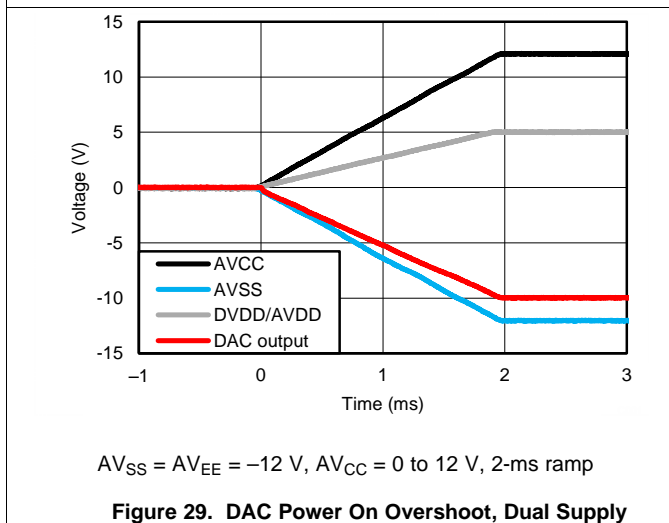

Figure 29. DAC Power On Overshoot, Dual Supply

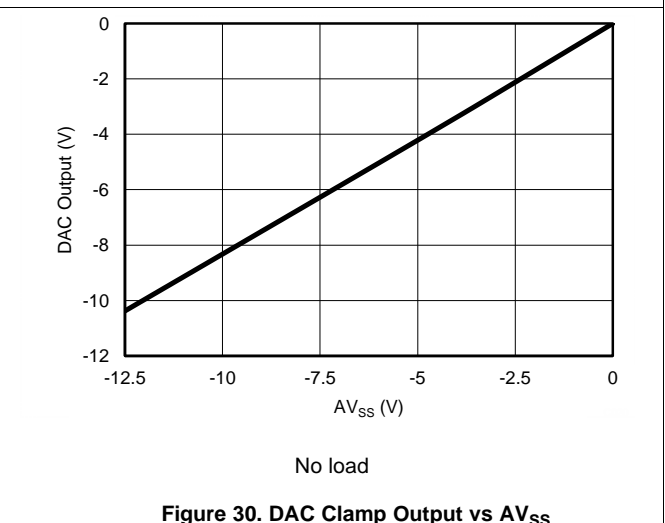

Figure 30. DAC Clamp Output vs AV_{SS}

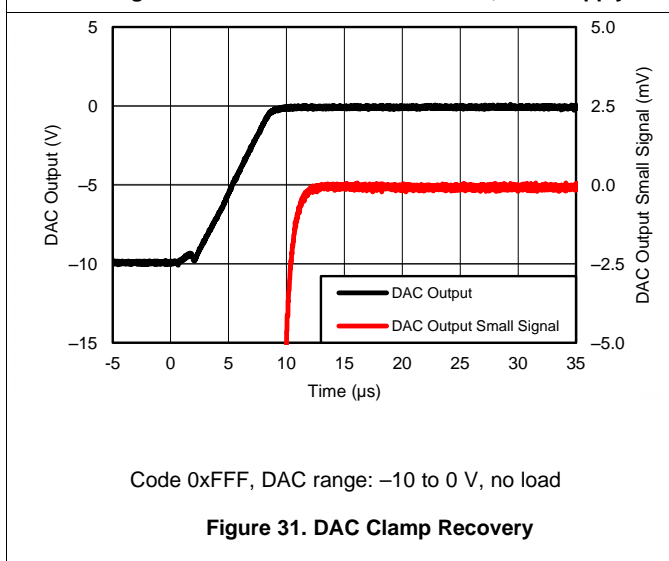

Figure 31. DAC Clamp Recovery

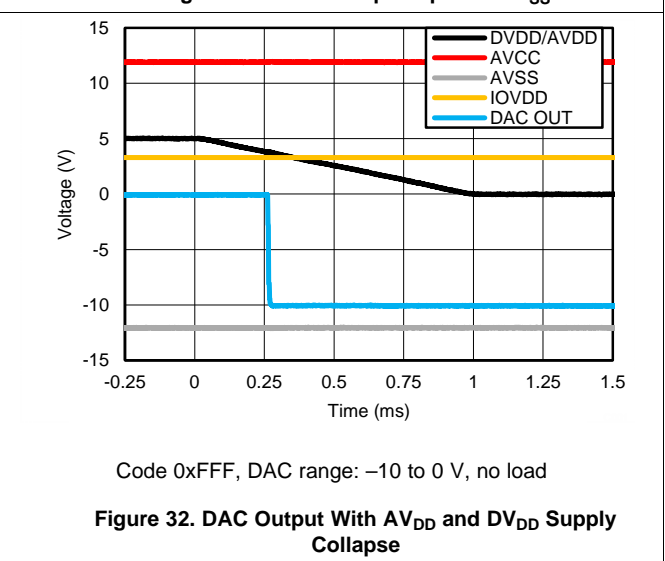
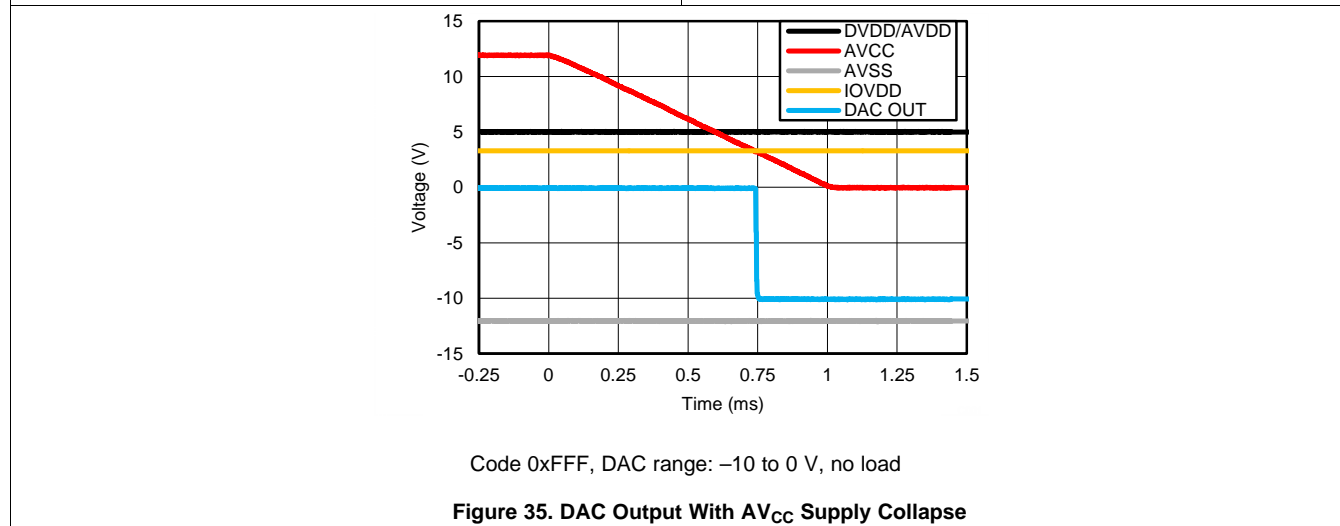
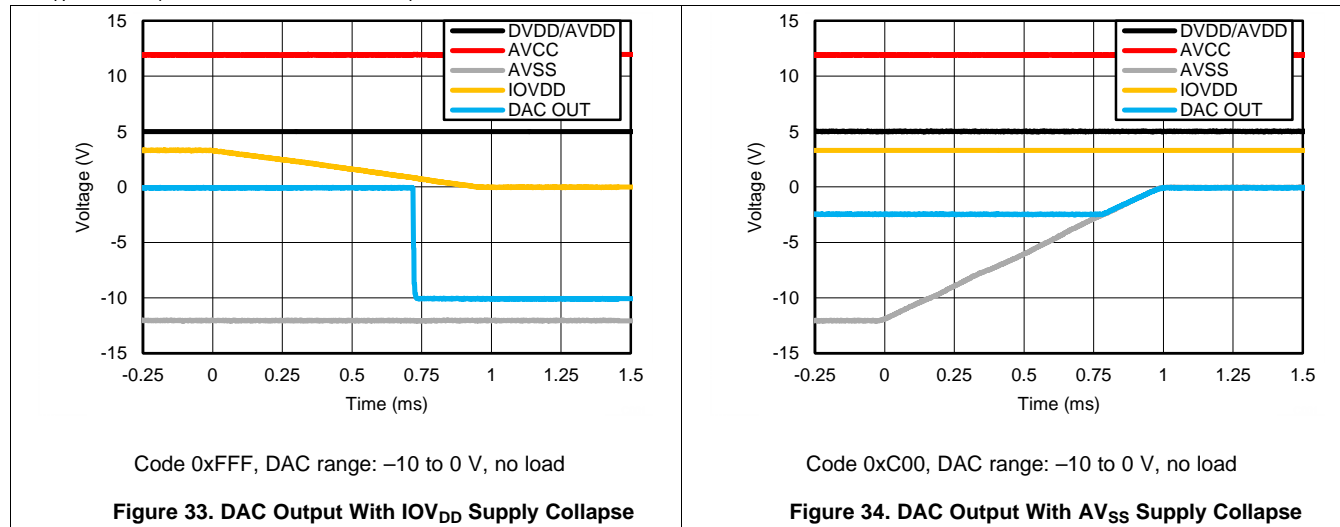

Figure 32. DAC Output With AV_{DD} and DV_{DD} Supply Collapse

Typical Characteristics: DAC (continued)

At $T_A = 25^\circ\text{C}$ (unless otherwise noted)



6.10 Typical Characteristics: ADC

At $T_A = 25^\circ\text{C}$ (unless otherwise noted)

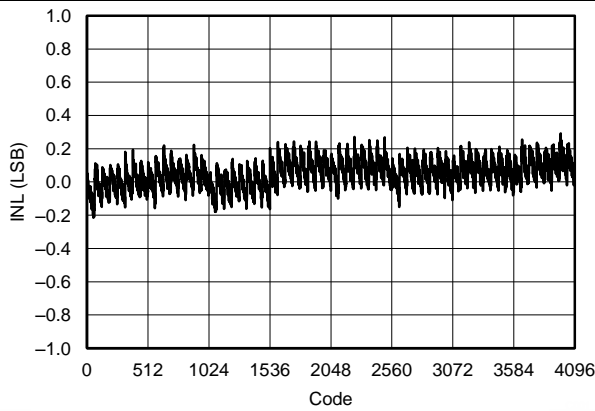

Figure 36. ADC Linearity Error vs Code Unipolar Input

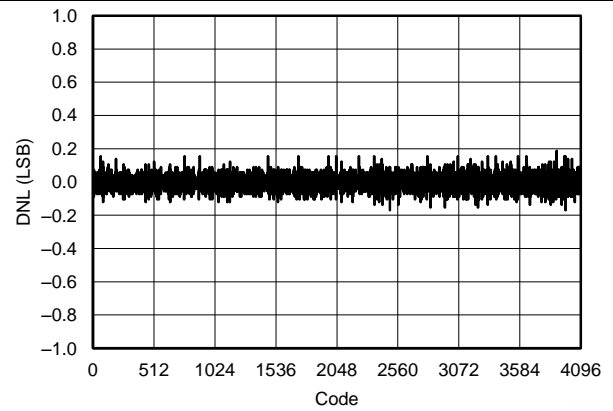

Figure 37. ADC Differential Linearity Error vs Code Unipolar Input

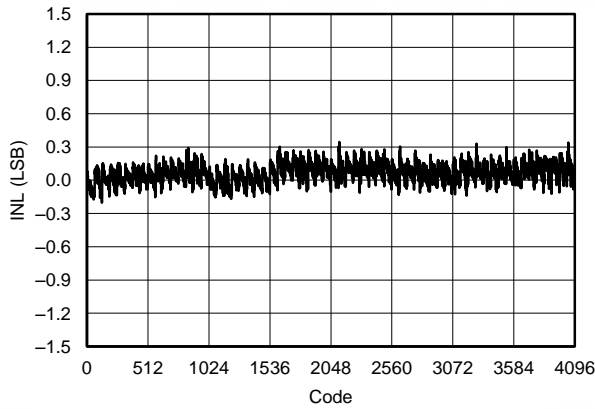

Figure 38. ADC Linearity Error vs Code Bipolar Input

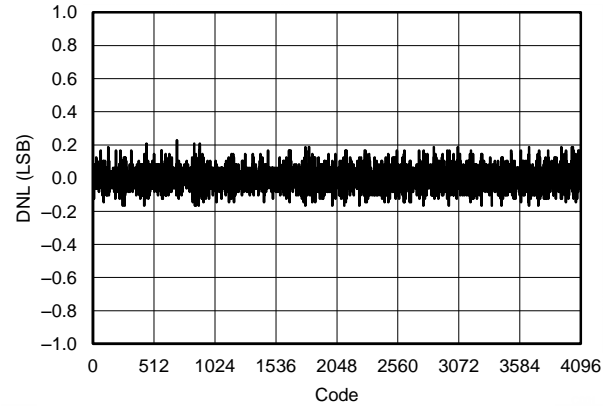

Figure 39. ADC Differential Linearity Error vs Code Bipolar Input

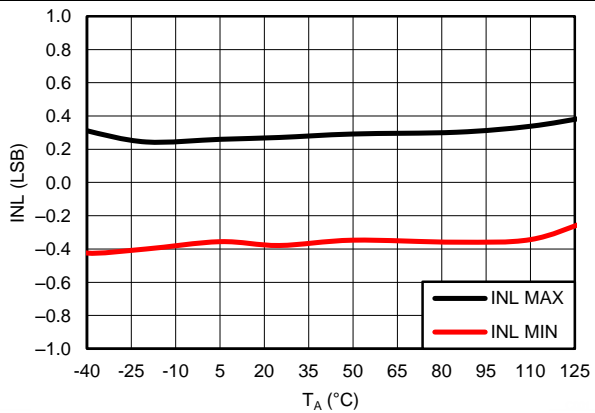

Figure 40. ADC Linearity Error vs Temperature Unipolar Input

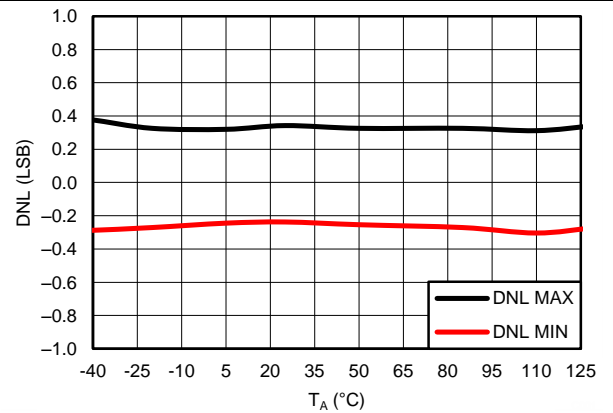

Figure 41. ADC Differential Linearity Error vs Temperature Unipolar Input

Typical Characteristics: ADC (continued)

At $T_A = 25^\circ\text{C}$ (unless otherwise noted)

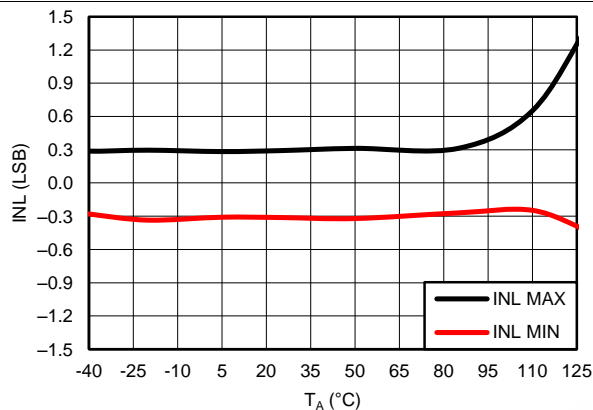

Figure 42. ADC Linearity Error vs Temperature Bipolar Input

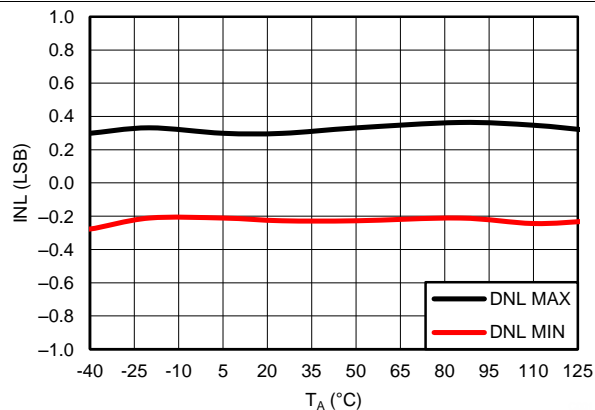

Figure 43. ADC Differential Linearity Error vs Temperature Bipolar Input

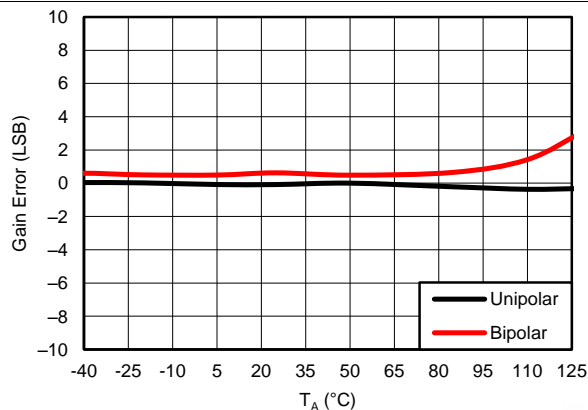

Figure 44. ADC Gain Error vs Temperature

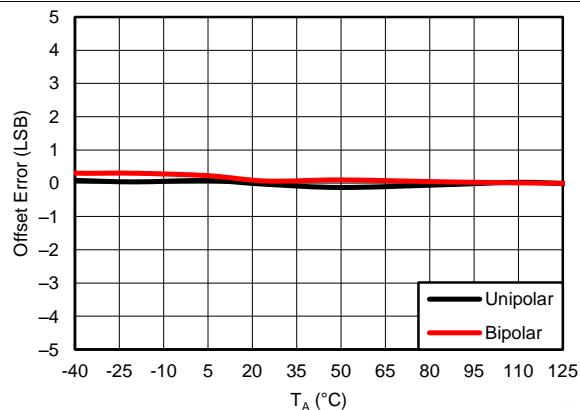
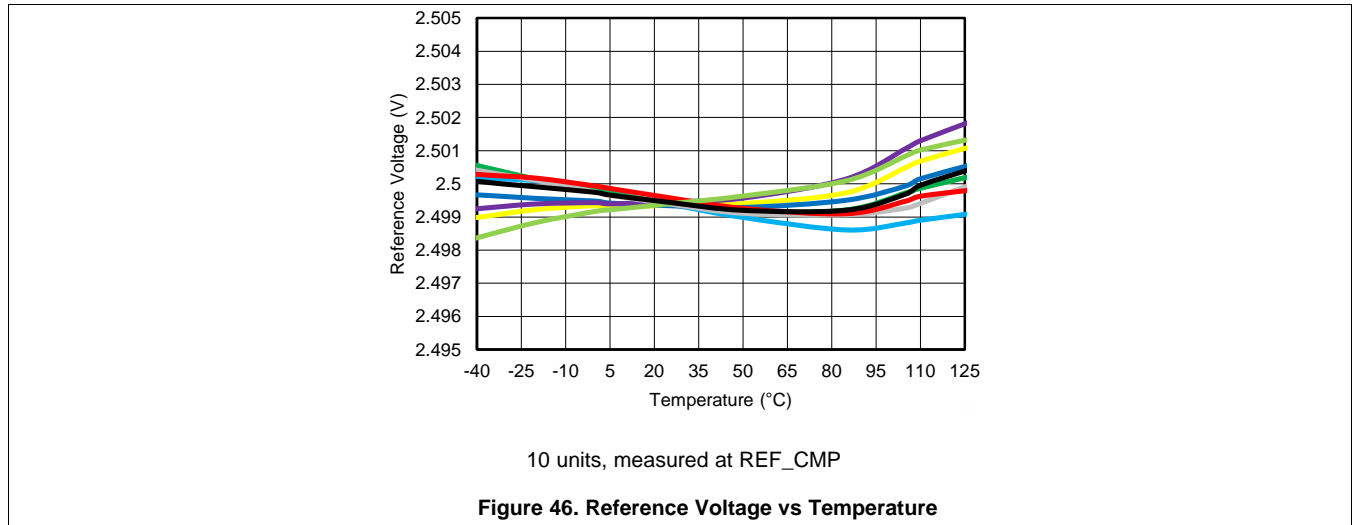

Figure 45. ADC Offset Error vs Temperature

6.11 Typical Characteristics: Reference

At $T_A = 25^\circ\text{C}$ (unless otherwise noted)



6.12 Typical Characteristics: Temperature Sensor

At $T_A = 25^\circ\text{C}$ (unless otherwise noted)

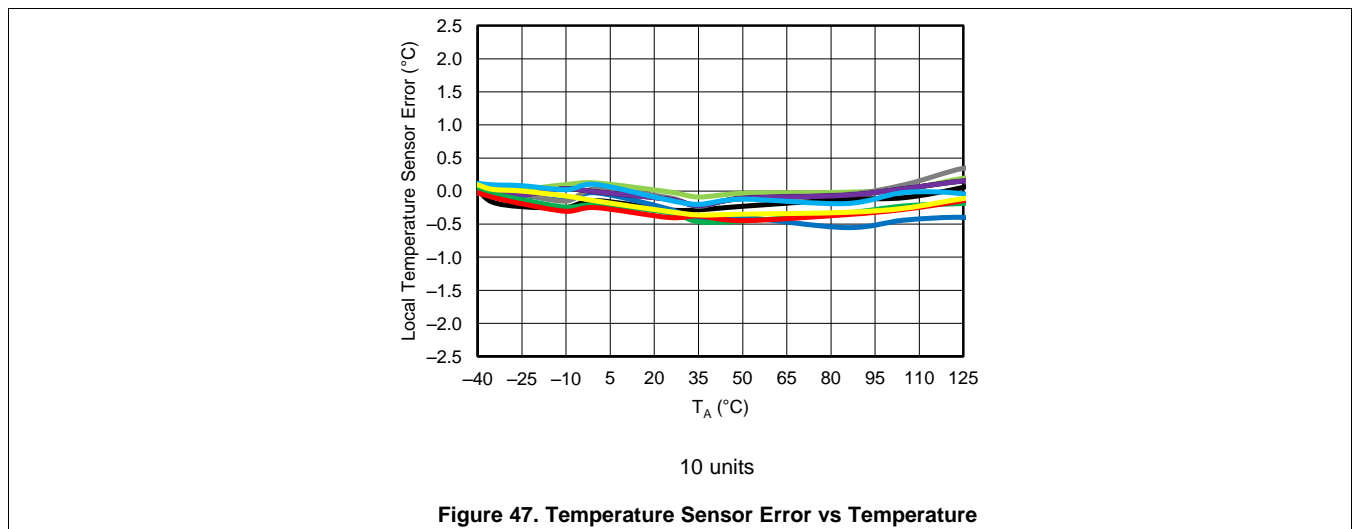

7 Detailed Description

7.1 Overview

The AMC7836 device is a highly-integrated analog-monitoring and control solution capable of voltage and temperature supervision. The AMC7836 device includes the following features:

- Sixteen 12-bit digital-to-analog converters (DACs) with adjustable output ranges
 - Output ranges: -10 to 0 V, -5 to 0 V, 0 to 5 V, and 0 to 10 V
 - Auto-range detector on device power-up and reset events
 - The DACs power-on and clamp voltages can be pin-selected between AGND and a negative voltage
 - The DACs can be configured to clamp automatically upon detection of an alarm event
- A multi-channel, 12-bit analog-to-digital converter (ADC) for voltage and temperature sensing
 - Sixteen bipolar inputs: -12.5 to 12.5 V input range
 - Five precision inputs with programmable threshold detectors: 0 to 5 V input range
 - Internal temperature sensor
- Internal 2.5 V precision reference
- Eight general purpose I/O (GPIO) ports
- Communication with the device occurs through a 4-wire SPI-compatible interface supporting 1.8 to 5.5 V operation

The AMC7836 device is characterized for operation over the temperature range of -40°C to 125°C which makes the device suitable for harsh-condition applications. The device is available in a $10\text{-mm} \times 10\text{-mm}$ 64-pin HTQFP PowerPAD IC package.

The very high-integration of the AMC7836 device makes it an ideal all-in-one, low-cost, bias-control circuit for the power amplifiers (PAs) found in multi-channel RF-communication systems. The flexible DAC output ranges allow the device to be used as a biasing solution for a large variety of transistor technologies such as LDMOS, GaAs, and GaN. The AMC7836 feature set is similarly beneficial in general-purpose monitor and control systems.

7.2 Functional Block Diagram

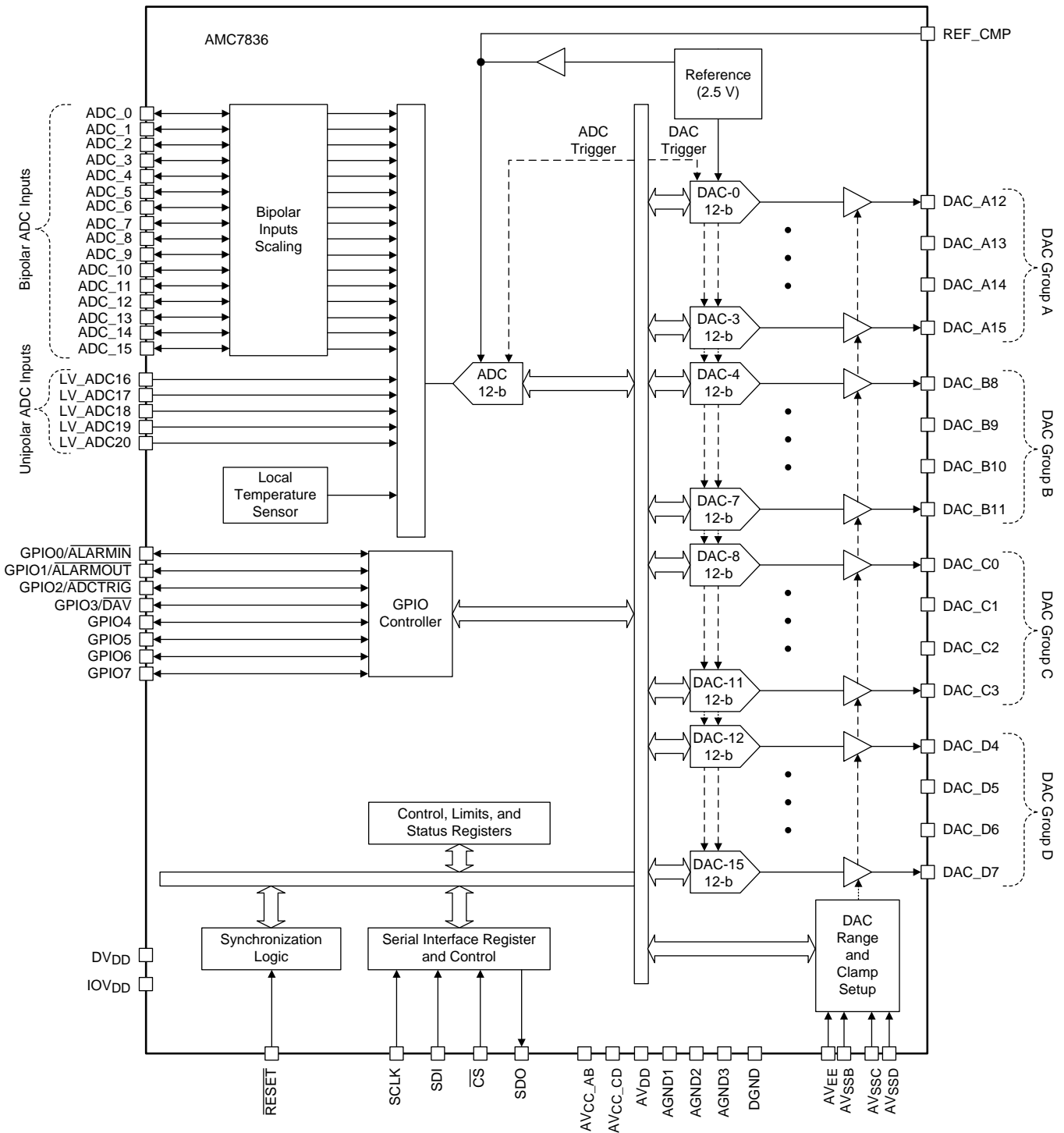

7.3 Feature Description

7.3.1 Digital-to-Analog Converters (DACs)

The AMC7836 device features an analog-control system centered on sixteen 12-bit DACs that operate from the internal reference of the device. Each DAC core consists of a string DAC and output-voltage buffer.

The resistor-string structure consists of a series of resistors, each with a value of R . The code loaded to the DAC determines at which node on the string the voltage is tapped off to be fed into the output amplifier. The voltage is tapped off by closing one of the switches connecting the string to the amplifier (see Figure 48). This architecture has inherent monotonicity, voltage output, and low glitch. This architecture is also linear because all the resistors are of equal value.

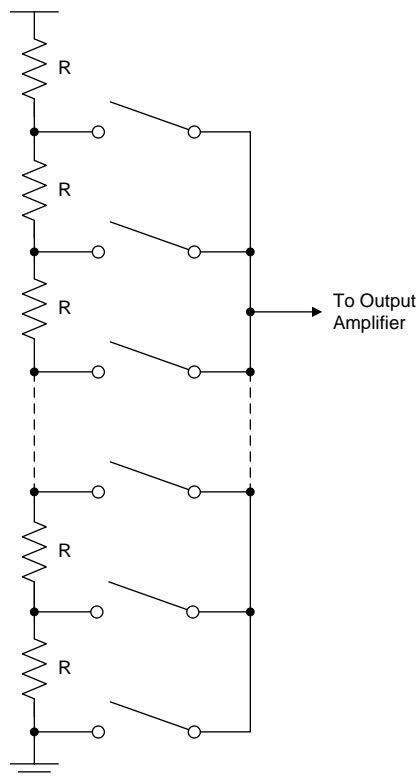

Figure 48. DAC Resistor String

7.3.1.1 DAC Output Range and Clamp Configuration

The 16 DACs are split into four groups, each with four DACs. All of the DACs in a given group share the same output range and clamp voltage value, however, these settings can be set independently for each DAC group. After power-on or a reset event the following actions take place: the DAC outputs are directed automatically to the corresponding clamp value; the DAC groups output ranges are set by the auto-range detector and; all DAC data registers and data latches are set to the default values. Figure 49 shows a high level block diagram of each DAC in the AMC7836 device.

Feature Description (continued)

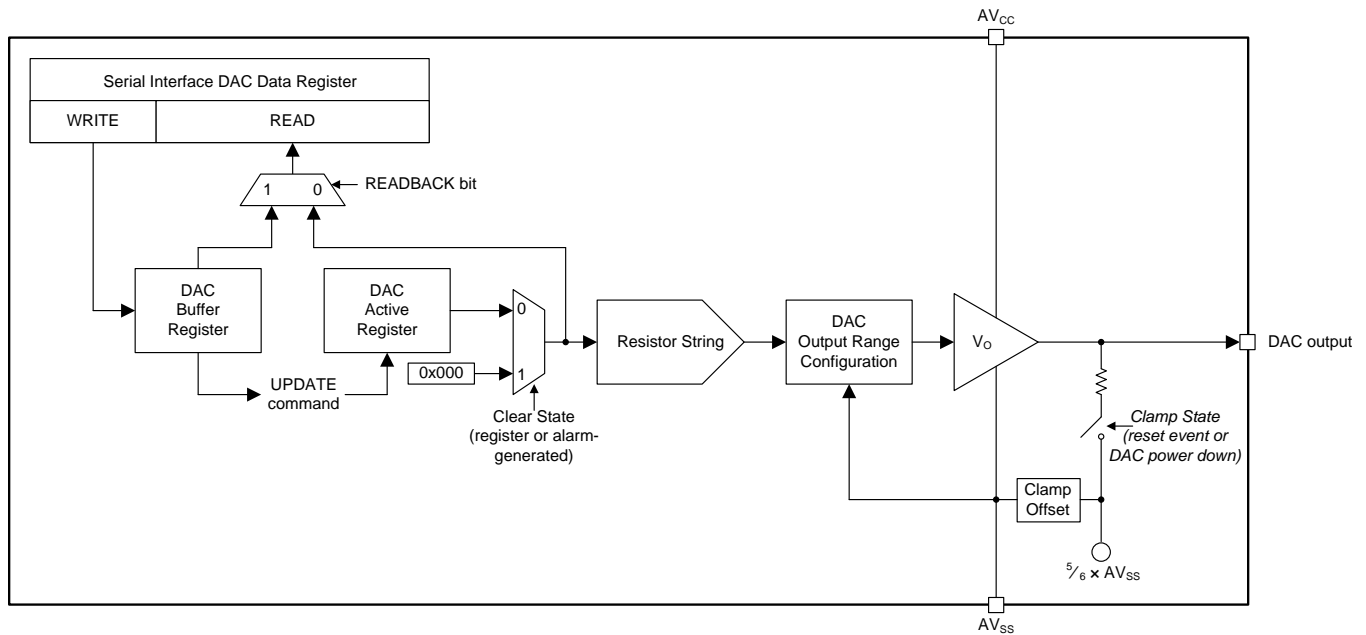

Figure 49. DAC Block Diagram

7.3.1.1.1 Auto-Range Detection

After power-on or a reset event the output range for each DAC group is set automatically by the voltage present in the corresponding AV_{SS} pin (AV_{EE}, AV_{SSB}, AV_{SSC} or AV_{SSD}). When the AV_{SS} voltage of a DAC group is lower than the threshold value, AV_{SS_{TH}}, the output for that DAC group is automatically configured to the –10 to 0 V range. Conversely, if the DAC group AV_{SS} voltage is higher than AV_{SS_{TH}}, the DAC-group output is automatically set to the 0 to 5 V range. The auto-range detector results for each DAC group are stored in the general status register (address 0x72).

In addition to a power-on or reset event, the auto-range detector is also enabled by a register write to the DAC power down registers (address 0xB2 through 0xB3) or the device configuration register (address 0x02).

Although the initial output-range setting is determined by the auto-range detector, the output range for each DAC-group can be afterwards configured to any of the available output ranges (–10 to 0 V, –5 to 0 V, 0 to 5 V, or 0 to 10 V) through the DAC range registers (address 0x1E through 0x1F).

NOTE

The power-on-reset and clamp-voltage value of each DAC group is set by the corresponding AV_{SS} pin and is independent of the DAC output range. In some applications, matching the clamp-voltage setting to the operating voltage range is imperative. For those applications, the recommended connections for the AV_{SS} pin are: AGND for the positive output ranges, in which case the clamp voltage is 0 V; a negative supply voltage with a lower value than the minimum DAC output voltage (–5 V or –10 V) for the selected negative output range, in which case the unloaded clamp voltage is determined by the value of the negative supply voltage (see Figure 50).

Although not a recommended operating condition, the device allows a DAC group to operate in a positive output range even if its clamp voltage is negative (AV_{SS} connected to a negative supply voltage).

Feature Description (continued)

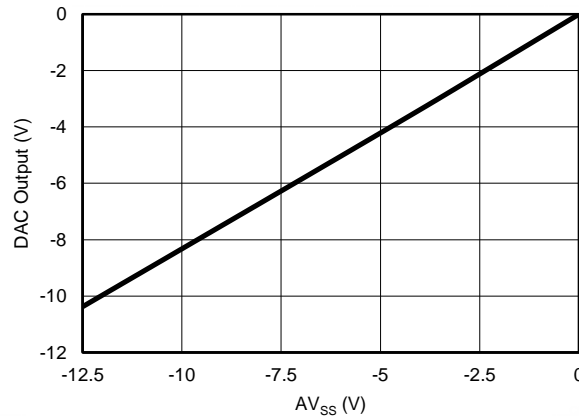

Figure 50. DAC Clamp Output vs AV_{SS}

A special distinction must be made for DAC group A as the AV_{SS} pin of this group is the dual-function AV_{EE} pin. Aside from setting the clamp voltage and default output range for the DAC group A, the AV_{EE} pin is also the lowest potential in the device. As a consequence the AV_{EE} voltage is dependent on the other AV_{SS} pin connections. The AV_{EE} pin can only be connected to the analog ground if all the other AV_{SS} pins are also connected to the analog ground. If any of the AV_{SS} pins is connected to a negative voltage, the AV_{EE} pin must also be connected to that voltage (see Table 1).

The full-scale output range for each DAC group is limited by the corresponding AV_{CC} and AV_{SS} values. The maximum and minimum outputs cannot exceed the AV_{CC} voltage or be lower than the AV_{SS} voltage, respectively.

Table 1. Recommended DAC Group Configuration

DAC GROUP	DAC	AUTO-RANGE AND CLAMP VOLTAGE SELECTION (AV _{SS})	AV _{EE} = AGND		AV _{EE} = V _{NEG}	
			OUTPUT RANGE	CLAMP VOLTAGE CONNECTION	OUTPUT RANGE	CLAMP VOLTAGE CONNECTION
A	DAC_A0	AV _{EE}	0 to 5 V or 0 to 10 V	AGND	-5 to 0 V or -10 to 0 V	V _{NEG}
	DAC_A1					
	DAC_A2					
	DAC_A3					
B	DAC_B4	AV _{SSB}	0 to 5 V or 0 to 10 V	AGND	-5 to 0 V or -10 to 0 V	V _{NEG} ≤ AV _{SSB} ≤ -5 V
	DAC_B5				0 to 5 V or 0 to 10 V	AGND
	DAC_B6					
	DAC_B7					
C	DAC_C8	AV _{SSC}	0 to 5 V or 0 to 10 V	AGND	-5 to 0 V or -10 to 0 V	V _{NEG} ≤ AV _{SSC} ≤ -5 V
	DAC_C9				0 to 5 V or 0 to 10 V	AGND
	DAC_C10					
	DAC_C11					
D	DAC_D12	AV _{SSD}	0 to 5 V or 0 to 10 V	AGND	-5 to 0 V or -10 to 0 V	V _{NEG} ≤ AV _{SSD} ≤ -5 V
	DAC_D13				0 to 5 V or 0 to 10 V	AGND
	DAC_D14					
	DAC_D15					

7.3.1.2 DAC Register Structure

The input data of the DACs is written to the individual DAC data registers (address 0x50 through 0x6F) in straight binary format for all output ranges (see [Table 2](#)).

Table 2. DAC Data Format

DIGITAL CODE	DAC OUTPUT VOLTAGE (V)			
	0 to 5 V RANGE	0 to 10 V RANGE	-5 to 0 V RANGE	-10 to 0 V RANGE
0000 0000 0000	0	0	-5	-10
0000 0000 0001	0.00122	0.00244	-4.99878	-9.99756
1000 0000 0000	2.5	5	-2.5	-5
1111 1111 1110	4.99756	9.99512	-0.00244	-0.00488
1111 1111 1111	4.99878	9.99756	-0.00122	-0.00244

Data written to the DAC data registers is initially stored in the DAC buffer registers. The transfer of data from the DAC buffer registers to the active registers is initiated by an update command in the register update register (address 0x0F). When the active registers are updated, the DAC outputs change to the new values.

The host has the option to read from either the buffer registers or the active registers when accessing the DAC data registers. The DAC read back option is configured by the READBACK bit in the interface configuration 1 register (address 0x01).

7.3.1.3 DAC Clear Operation

Each DAC can be set to a CLEAR state using either hardware or software. When a DAC goes to CLEAR state, it is loaded with a zero-code input and the output voltage is set according to the operating output range. The DAC buffer or active registers do not change when the DACs enter the CLEAR state which makes it possible to return to the same voltage output before the clear event was issued. Even though the contents of the active register do not change while a DAC is in CLEAR state, a data-register read operation from the active registers while in this state returns zero-code. This functionality enables the ability to determine the DAC output voltage regardless of the operating state (CLEAR or NORMAL).

NOTE

The DAC buffer and active registers can be updated while the DACs are in CLEAR state allowing the DACs to output new values upon return to normal operation. When the DACs exit the CLEAR state, the DACs are immediately loaded with the data in the DAC active registers and the output is set back to the corresponding level to restore operation.

The DAC clear registers (address 0xB0 through 0xB1) enable independent control of each DAC CLEAR state through software. The DACs can also be forced to enter a CLEAR state through hardware using the ALARMIN pin. See the [Programmable Out-of-Range Alarms](#) section for a detailed description of this method.

The ALARMIN-controlled clear mechanism is just a special case of the device capability to force the DACs into the CLEAR state as a response to an alarm event. To enable this function, the alarm events must first be enabled as DAC-clear alarm sources in the DAC clear source registers (address 0x1A through 0x1B). The DAC outputs to be cleared by the selected alarm events must also be specified in the DAC clear enable registers (address 0x18 through 0x19).

An alarm event sets the corresponding alarm bit in the alarm status registers. In addition all the DACs set to clear in response to the alarm event in the DAC clear enable registers enter a CLEAR state. Once the alarm bit is cleared, as long as no other CLEAR-state controlling alarm events have been triggered, the DACs are reloaded with the contents of the DAC active registers and the outputs update accordingly.

7.3.2 Analog-to-Digital Converter (ADC)

The AMC7836 features a monitoring system centered on a 12-bit SAR (successive approximation register) ADC fronted by a 22-channel multiplexer and an on-chip track-and-hold circuit. The monitoring system is capable of sensing up to 16 external bipolar inputs (–12.5 to 12.5 V range), five external unipolar inputs (0 to 5 V range), and an internal analog temperature sensor.

The ADC operates from an internal 2.5 V reference (V_{ref} , measured at the REF_CMP pin) and the input range is 0 V to $2 \times V_{ref}$. The external bipolar inputs to the ADC are internally mapped to this range. The ADC timing signals are derived from an on-chip temperature-compensated oscillator. The conversion results can be accessed through the device serial interface.

7.3.2.1 Analog Inputs

The AMC7836 has 21 analog inputs for external voltage sensing. Sixteen of these inputs (ADC_0 through ADC_15) are bipolar and the other five (LV_ADC16 through LV_ADC20) are unipolar. Figure 51 shows the equivalent circuit for the external analog-input pins. All switches are open while the ADC is in the IDLE state.

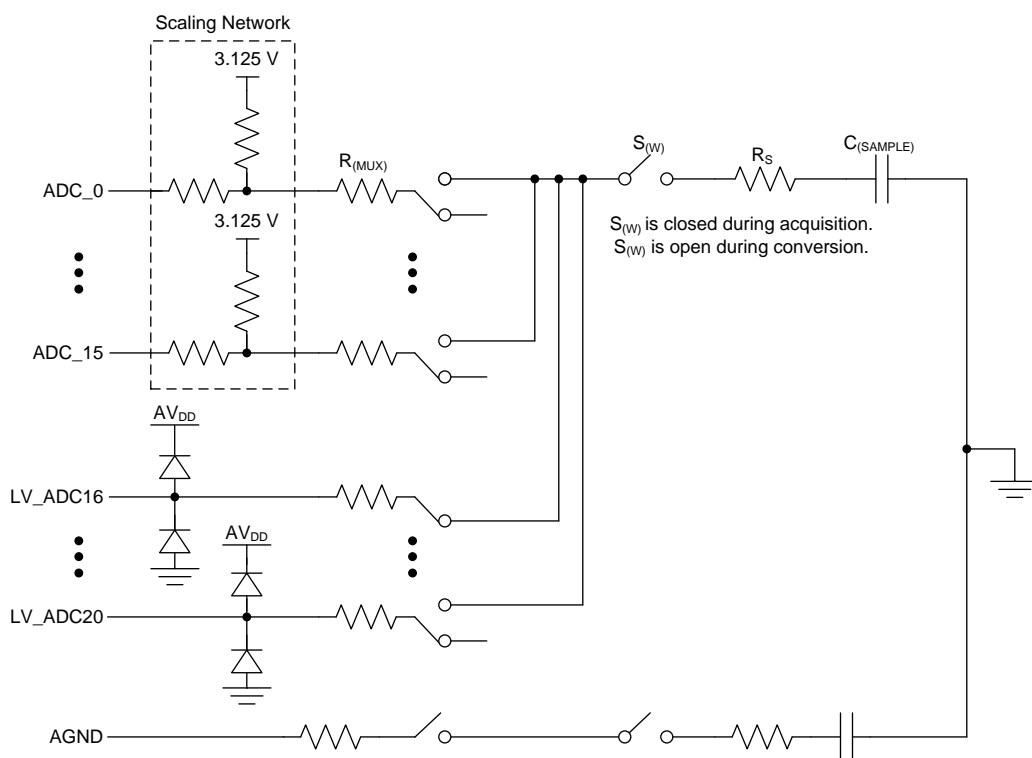

Figure 51. ADC External Inputs Equivalent Circuit

To achieve the specified performance, especially at higher input frequencies, driving each analog input pin with a low impedance source is recommended. An external amplifier can also be used to drive the input pins.

7.3.2.1.1 Bipolar Analog Inputs

The AMC7836 can support up to 16 bipolar analog inputs. The analog input range for these channels is –12.5 to 12.5 V. The bipolar signal is scaled internally through a resistor divider so that it maps to the native input range of the ADC (0 V to $2 \times V_{ref}$). The input resistance of the scaling network is 175 k Ω .

The bipolar analog input conversion values are stored in straight binary format in the ADC data registers (address 0x20 through 0x49). The LSB (least-significant bit) size for these channels is $25 \times V_{ref} / 4096$. With the internal reference equal to 2.5 V, the input voltage is calculated by [Equation 1](#).

$$\text{Voltage} = 5 \left(\frac{\text{CODE} \times 5}{4096} - 2.5 \right) \quad (1)$$

A typical application for the bipolar channels is monitoring of the 16 DAC outputs in the device. In this application the bipolar inputs can be driven directly. However, in applications where the signal source has high impedance, buffering the analog input is recommended. When driven from a low impedance source such as the AMC7836 DAC outputs, the network is designed to settle before the start of conversion. Additional impedance can affect the settling and divider accuracy of this network.

7.3.2.1.2 Unipolar Analog Inputs

In addition to the bipolar input channels, the AMC7836 device includes five unipolar analog inputs. The analog input range for these channels is 0 V to $2 \times V_{ref}$ and the LSB size for these channels is $2 \times V_{ref} / 4096$.

The unipolar analog input conversion values are stored in straight binary format in the ADC-Data registers (address 0x40 through 0x49). With the internal reference equal to 2.5 V, the input voltage is calculated by [Equation 2](#).

$$\text{Voltage} = \frac{\text{CODE} \times 5}{4096} \quad (2)$$

In applications where the signal source has high impedance, externally buffering the unipolar analog input is recommended.

7.3.2.2 ADC Sequencing

The AMC7836 ADC conversion sequence is shown in [Figure 52](#). The ADC supports direct mode and auto mode conversion. The conversion method is selected in the ADC configuration register (address 0x10). The default conversion method is direct mode.

In both methods, the single channel or sequence of channels to be converted by the ADC must be first configured in the ADC MUX configuration registers (address 0x13 through 0x15). The input channels to the ADC include 16 external bipolar inputs, five external unipolar inputs, and the internal temperature sensor.

In direct-mode conversion, the selected ADC input channels are converted on demand by issuing an ADC trigger signal. After the last enabled channel is converted, the ADC enters IDLE state and waits for a new trigger.

In auto-mode conversion, the selected ADC input channels are converted continuously. The conversion cycle is initiated by issuing an ADC trigger. Upon completion of the first conversion sequence another sequence is automatically started. Conversion of the selected channels occurs repeatedly until the auto-mode conversion is stopped by issuing a second trigger signal.

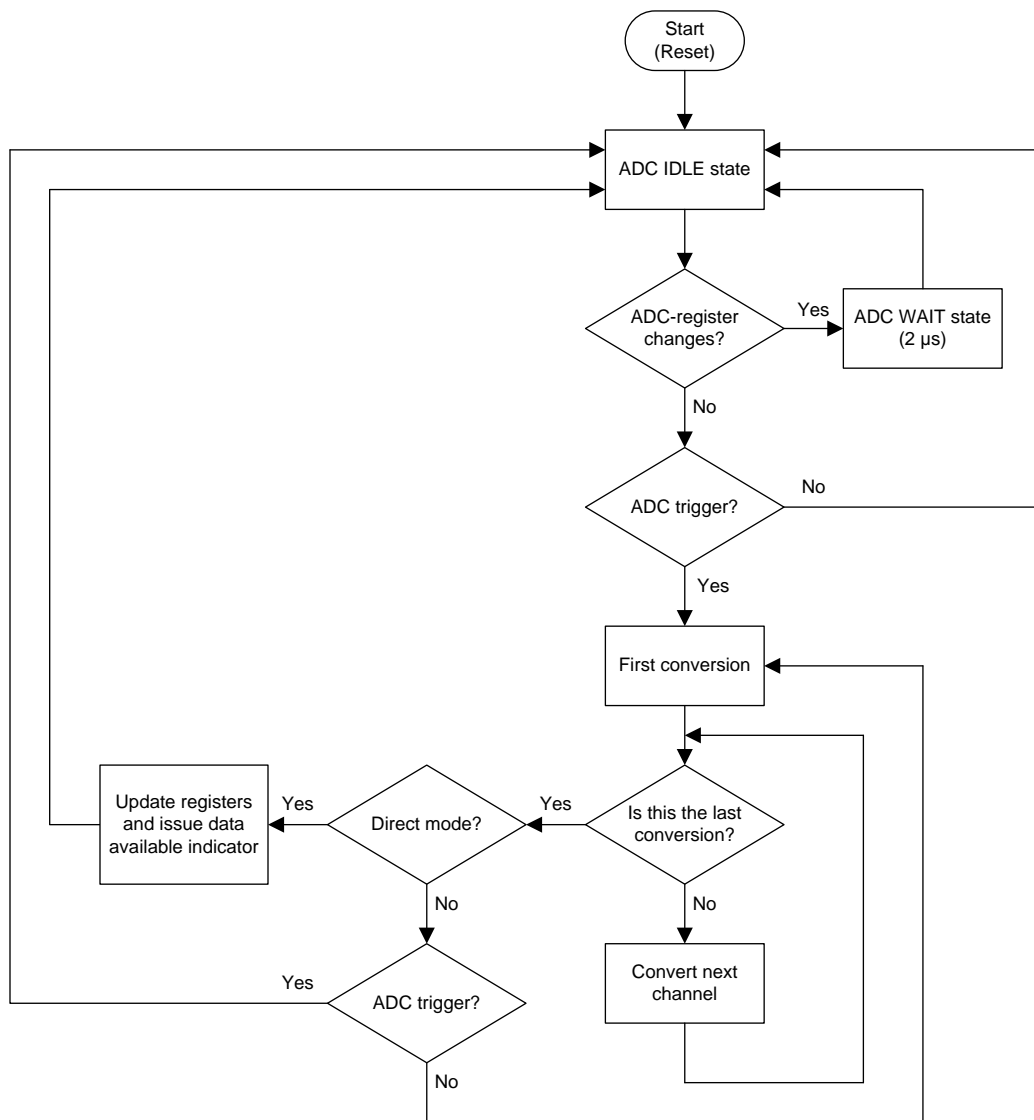

Figure 52. ADC Conversion Sequence

Regardless of the selected conversion method, the following ADC registers should only be updated while the ADC is in IDLE state:

- ADC configuration register (address 0x10)
- False alarm configuration register (address 0x11)
- ADC MUX configuration registers (address 0x13 through 0x15)
- Threshold registers (0x80 through 0x97)
- Hysteresis register (0xA0 through 0xA5)

NOTE

After updating any of the ADC registers listed above, a minimum 2 μs wait time should be implemented before issuing an ADC trigger.

7.3.2.3 ADC Synchronization

A trigger signal must occur for the ADC to enter and exit the IDLE state. The ADC trigger can be generated either through software (ICONV bit in the ADC trigger register, 0xC0) or hardware (GPIO2/ADCTRIG, pin 9). To use the GPIO2/ADCTRIG pin as an ADC trigger, the pin must be configured accordingly in the GPIO configuration register (address 0x12). When the pin is configured as a trigger, a falling edge on it begins the sampling and conversion of the ADC.

In auto mode the ADC and temperature data registers (0x20 through 0x4B) are accessed by first issuing an ADC UPDATE command in the register update register (address 0x0F). The ADC UPDATE command ensures the latest available data for each input channel can be accessed without the need for complex synchronization schemes between the AMC7836 device and the host controller. A single ADC UPDATE command updates all ADC and temperature data registers. Therefore issuing multiple UPDATE commands is not necessary when reading more than one ADC data register.

NOTE

The ADC UPDATE command and accessing of the ADC and Temperature data registers does not interfere with the conversion process which ensures continuous ADC operation.

In direct mode the ADC and temperature data registers (0x20 through 0x4B) should only be accessed while the ADC is in the IDLE state (see [Figure 53](#)). Although the total update time can be easily calculated, the device provides a data-available indicator signal to track the ADC status. Failure to satisfy the synchronization requirements could lead to erroneous data reads.

The data-available indicator signal is output through the GPIO3/DAV pin and as a data-available flag that is accessible through the serial interface (DAVF bit in the general status register, 0x72). The GPIO3/DAV pin must be configured in the GPIO configuration register (address 0x12) as an interrupt. After a direct-mode conversion is complete and the ADC returns to the IDLE state, the DAVF bit is immediately set to 1 and the DAV pin is active (low) which indicates that new data is available. The pin and flag are cleared automatically when a new conversion begins or one of the ADC data or temperature data registers is accessed.

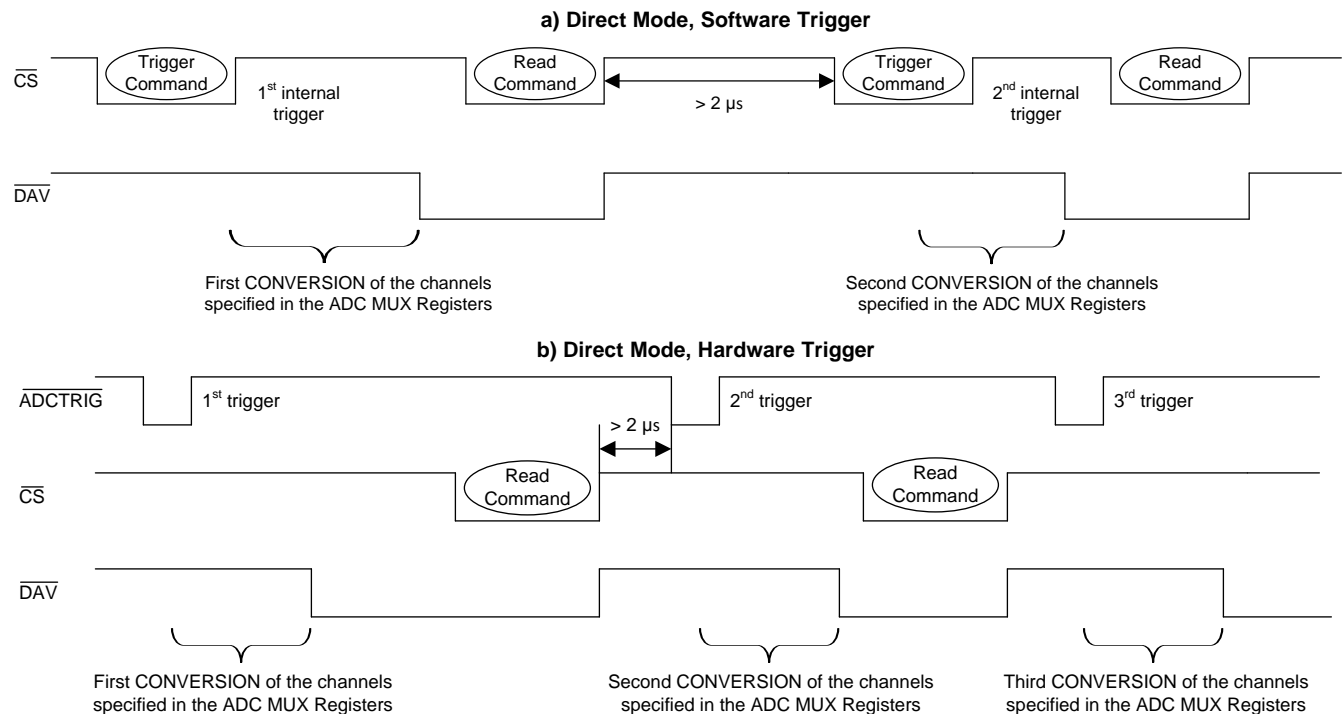

Figure 53. ADC Direct-Mode Trigger Synchronization

7.3.2.4 Programmable Out-of-Range Alarms

The AMC7836 device is capable of continuously analyzing the five external unipolar inputs and internal temperature sensor conversion results for normal operation.

Normal operation is established through the lower and upper threshold registers (address 0x80 through 0x97). When any of the monitored inputs is out of the specified range, an alarm event is issued and the global alarm bit, GALR in the general status register (0x72), is set (see Figure 54). Use the alarm status registers (0x70 through 0x71) to determine the source of the alarm event.

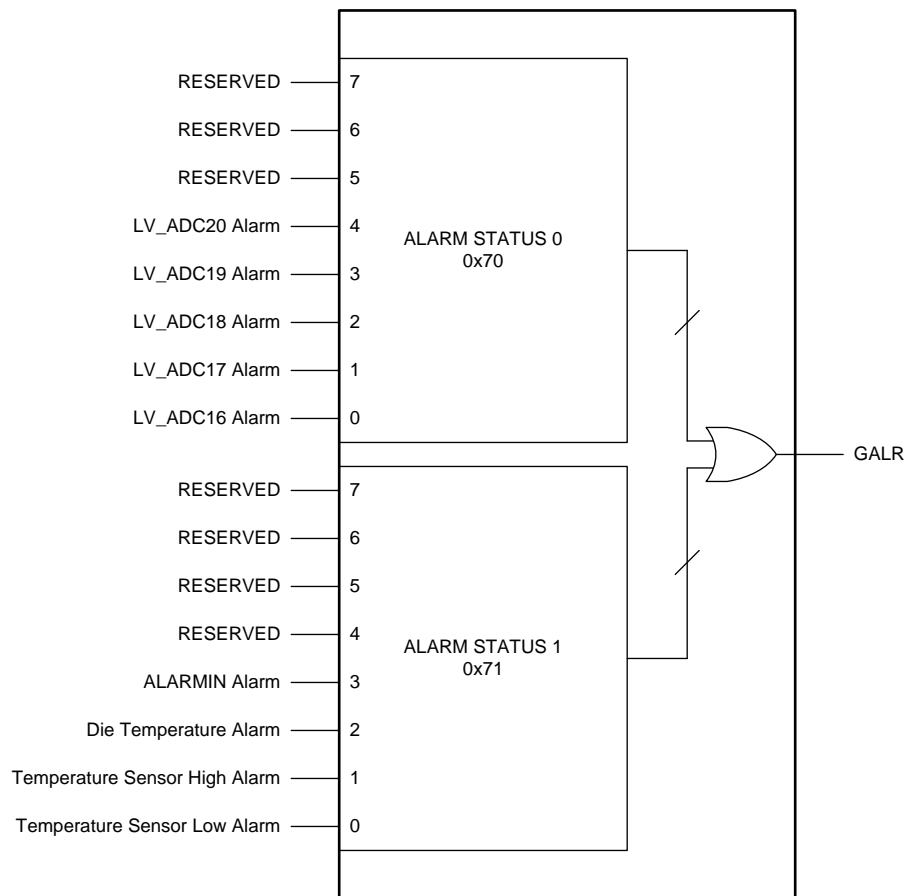

Figure 54. Alarm Status Register

The ALARM-LATCH-DIS bit in the $\overline{\text{ALARMOUT}}$ source 1 register (address 0x1D) sets the latching behavior for all alarms (except for the $\overline{\text{ALARMIN}}$ alarm which is always unlatched). When the ALARM-LATCH-DIS bit is cleared to 0 the alarm bits in the alarm status registers are latched. The alarm bits are referred to as being latched because they remain set until read by software. This design ensures that out-of-limit events cannot be missed if the software is polling the device periodically. All bits are cleared when reading the alarm status registers, and all bits are reasserted if the out-of limit condition still exists on the next monitoring cycle, unless otherwise noted. When the ALARM-LATCH-DIS bit is set to 1, the alarm bits are not latched. The alarm bits in the alarm status registers are set to 0 when the error condition subsides, regardless of whether the bit is read or not.

All of the alarms can be set to activate the $\overline{\text{ALARMOUT}}$ pin. To enable this functionality, the $\text{GPIO1}/\overline{\text{ALARMOUT}}$ pin must be configured accordingly in the GPIO configuration register (address 0x12). The $\overline{\text{ALARMOUT}}$ pin works as an interrupt to the host so that it can query the alarm status registers to determine the alarm source. Any alarm event can activate the pin as long as the alarm is not masked in the $\overline{\text{ALARMOUT}}$ source registers (address 0x1C through 0x1D). When an alarm event is masked, the occurrence of the event sets the corresponding status bit in the alarm status registers, but does not activate the $\overline{\text{ALARMOUT}}$ pin.

7.3.2.4.1 Unipolar Inputs Out-of-Range Alarms

The AMC7836 device provides out-of-range detection for the five external unipolar ADC inputs (LV_ADC16 through LV_ADC20, pins 35 through 39). [Figure 55](#) shows the out-of-range detection block. When the measurement is out-of-range, the corresponding alarm bit in the alarm status 0 register (address 0x70) is set to 1 to flag the out-of-range condition. The values in the ADC upper and lower Threshold registers (address 0x80 through 0x93) define the upper and lower bound thresholds for all five inputs.

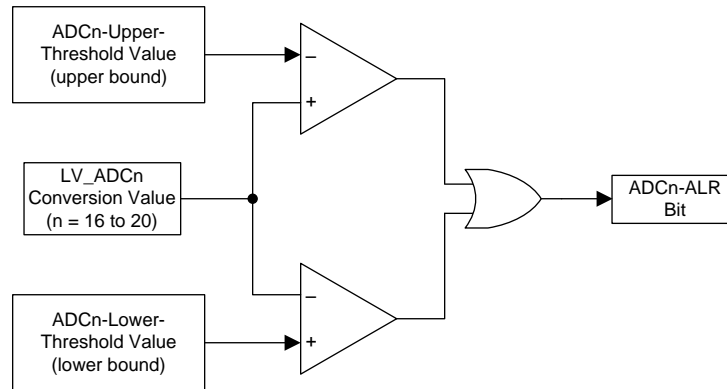

Figure 55. Unipolar Inputs Out-of-Range Alarms

7.3.2.4.2 Unipolar Inputs Out-of-Range Alarms

The AMC7836 includes high-limit and low-limit detection for the internal temperature sensor. [Figure 56](#) shows the temperature detection block. The values in the LT upper and lower threshold registers (address 0x94 through 0x97) set the limits for the temperature sensor. The temperature sensor detector can issue either a high-alarm (LT-HIGH-ALR bit) or a low-alarm (LT-LOW-ALR bit) in the alarm status 1 register (address 0x71) depending on whether the high or low thresholds were exceeded. To implement single, upper-bound threshold detection for the temperature sensor, the host processor can set the upper-bound threshold to the desired value and the lower-bound threshold to the default value. For lower-bound threshold detection, the host processor can set the lower-bound threshold to the desired value and the upper-bound threshold to the default value.

In addition to the programmable threshold alarms the temperature sensor detection circuit also includes a die thermal-alarm flag which continuously monitors the die temperature. When the die temperatures exceeds 150°C the die thermal alarm flag (THERM-ALR bit) in the alarm status 1 register (address 0x71) is set. The internal temperature sensor must be enabled for this alarm to be functional.

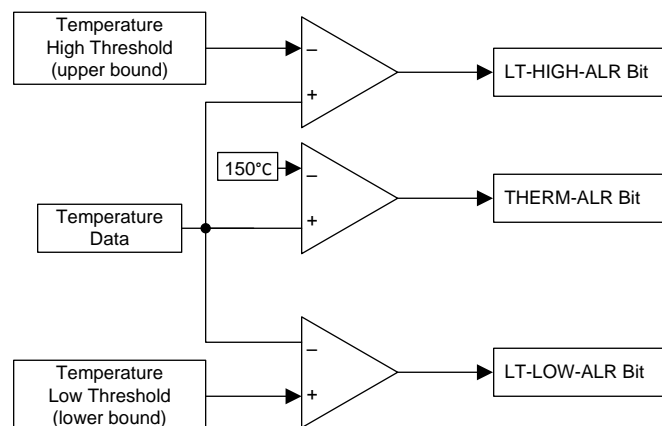

Figure 56. Internal Temperature Out-of-Range Alarms

7.3.2.4.3 ALARMIN Alarm

The AMC7836 device offers the option of using an external interrupt signal, such as the output of a comparator as an alarm event. The GPIO0/ALARMIN pin is used as the alarm input and must be configured accordingly in the GPIO configuration register (address 0x12). The pin is active low when configured as an alarm input.

A typical application for ALARMIN pin is to use it as a hardware interrupt that is responsible for forcing one or more DACs to a CLEAR state. The DAC is loaded with a zero-code input and the output voltage is set according to the operating output range, however the DAC buffer or active registers do not change (see the [Digital-to-Analog Converters \(DACs\)](#) section for more details). To enable this functionality the ALARMIN pin must be enabled as a DAC clear-alarm source in the DAC clear source 1 register (address 0x1B). Additionally the DAC outputs to be cleared by the ALARMIN pin must be specified in the DAC clear enable registers (address 0x18 through 0x19).

In this application when the ALARMIN pin goes low, all the DACs that are set to clear in response to the ALARMIN alarm in the DAC-clear enable registers enter a CLEAR state. When the ALARMIN pin goes back high the DACs are reloaded with the contents of the DAC active registers which allows the DAC outputs to return to the previous operating point without any additional commands.

7.3.2.4.4 Hysteresis

If a monitored signal is out of range and the alarm is enabled, the corresponding alarm bit is set to 1. However, the alarm condition is cleared only when the conversion result returns either a value lower than the high threshold register setting or higher than the low threshold register setting by the number of codes specified in the hysteresis setting (see [Figure 57](#)). The ADC and LT hysteresis registers (address 0xA0 through 0xA4) store the hysteresis value for the external unipolar inputs and internal temperature sensor programmable alarms. The hysteresis is a programmable value between 0 LSB to 127 LSB for the unipolar inputs alarms and 0°C to 31°C for the internal temperature-sensor alarms. The die thermal alarm hysteresis is fixed at 8°C.

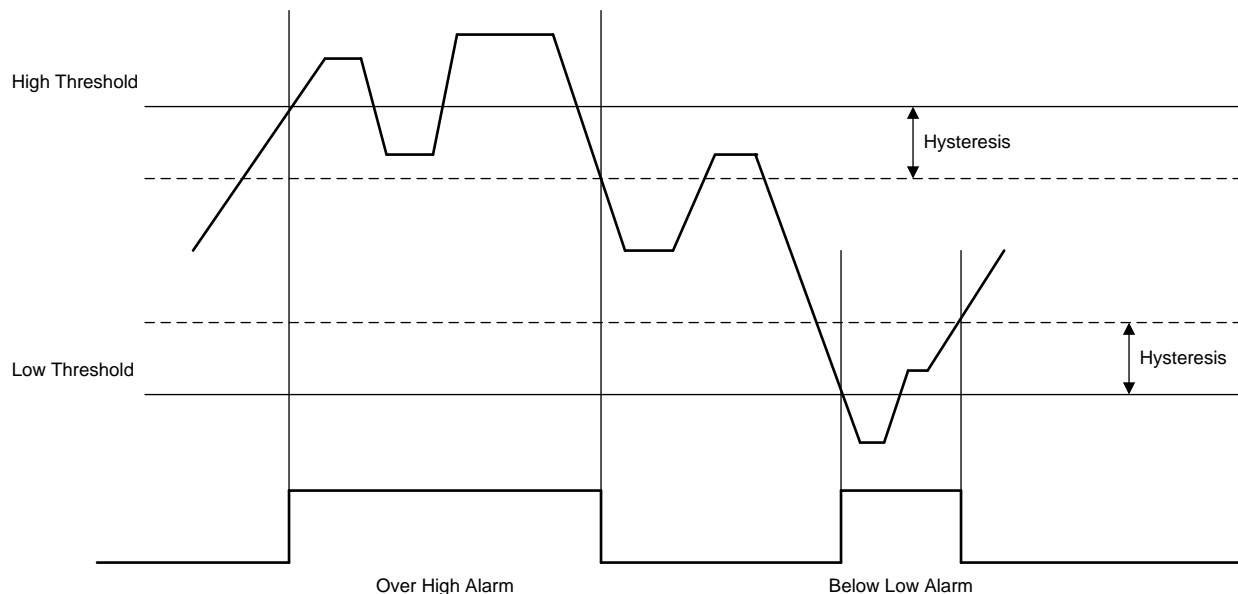

Figure 57. Device Hysteresis

7.3.2.4.5 False-Alarm Protection

To prevent false alarms, an alarm event is only registered when the monitored signal is out of range for an *N* number of consecutive conversions. If the monitored signal returns to the normal range before *N* consecutive conversions, an alarm event is not issued. The false alarm factor, *N*, for the unipolar input and local temperature sensor out-of-range alarms can be configured in the false alarm configuration register (address 0x11).

7.3.3 Internal Temperature Sensor

The AMC7836 device has an on-chip temperature sensor that measures the device die temperature. The normal operating temperature range for the internal temperature sensor is limited by the operating temperature range of the device (–40°C to 125°C).

The temperature sensor results are converted by the device ADC at a lower speed than the analog input channels. The temperature can be monitored either continuously or as a single-time conversion depending on whether the ADC is configured in auto mode or direct mode (see the [Analog-to-Digital Converter \(ADC\)](#) section for more details). If the temperature sensor is not needed, it can be disabled in the ADC MUX configuration 2 register (address 0x15). When disabled, the temperature sensor output is not converted by the ADC.

The temperature sensor provides 0.25°C resolution over the operating temperature range. The temperature value is stored in 12-bit two's complement format in the temperature data registers (address 0x78 through 0x79).

Table 3. Temperature Sensor Data Format

TEMPERATURE (°C)	DIGITAL CODE
–40	1111 0110 0000
–25	1111 1001 1100
–10	1111 1101 1000
–0.25	1111 1111 1111
0	0000 0000 0000
0.25	0000 0000 0001
10	0000 0010 1000
25	0000 0110 0100
50	0000 1100 1000
75	0001 0010 1100
100	0001 1001 0000
105	0001 1010 0100
125	0001 1111 0100

Use [Equation 3](#) and [Equation 4](#) to calculate the positive or negative temperature according to the polarity of the temperature data MSB (0 - positive, 1 - negative).

$$\text{Positive Temperature (°C)} = \frac{\text{ADC_Code}}{4} \quad (3)$$

$$\text{Negative Temperature (°C)} = \frac{4096 - \text{ADC_Code}}{4} \quad (4)$$

7.3.4 Internal Reference

The AMC7836 device includes a high-performance internal reference for the on-chip ADC and 16 DACs (see Figure 58). The internal reference is a 2.5 V, bipolar transistor-based, precision bandgap reference. A compensation capacitor (4.7 μ F, typical) should be connected between the REF_CMP pin and the AGND2 pin.

The AMC7836 device includes a buffer to drive the ADC and should not be used to drive any external circuitry. The ADC reference buffer is powered down by default and should be enabled in the ADC configuration register (address 0x10) during device initialization.

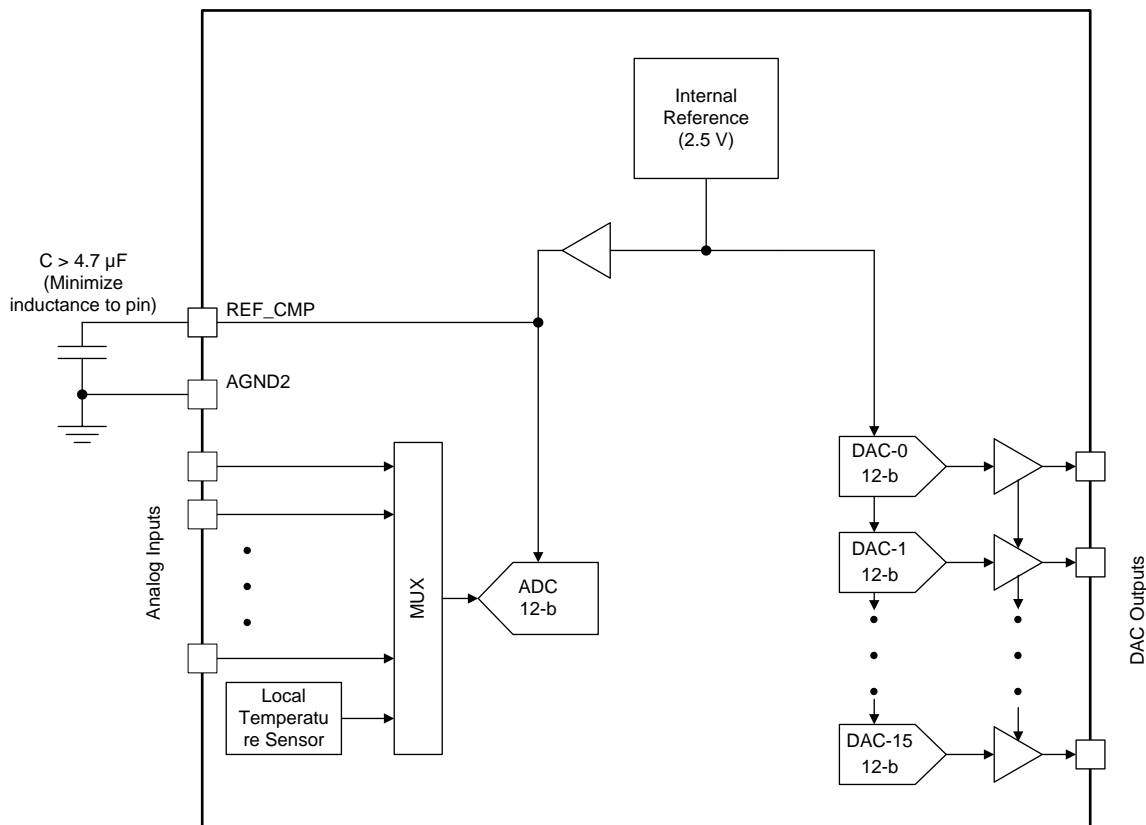

Figure 58. AMC7836 Internal Reference

7.3.5 General Purpose I/Os

The AMC7836 device includes eight GPIO pins, each with an internal 48-kΩ pullup resistor to the IOV_{DD} pin. The GPIO[0:3] pins have dual functionality and can be programmed as either bidirectional digital I/O pins or interrupt signals in the GPIO configuration register (address 0x12). The GPIO[4:7] pins are dedicated GPIOs. Table 4 lists the dual function of the GPIO[0:3] pins.

Table 4. Dual Functionality GPIO Pins

PIN	DEFAULT PIN NAME	ALTERNATIVE PIN NAME	ALTERNATIVE FUNCTIONALITY
7	GPIO0	$\overline{\text{ALARMIN}}$	DAC clear control signal.
8	GPIO1	$\overline{\text{ALARMOUT}}$	Global alarm output.
9	GPIO2	$\overline{\text{ADCTRIG}}$	External ADC conversion trigger.
10	GPIO3	$\overline{\text{DAV}}$	ADC data available indicator.

The GPIOs can receive an input or produce an output. When the GPIO_n pin acts as an output, the status of the pin is determined by the corresponding GPIO bit in the GPIO register (address 0x7A).

To use a GPIO_n pin as an input, the corresponding GPIO bit in the GPIO register must be set to 1. When a GPIO_n pin acts as input, the digital value on the pin is acquired by reading the corresponding GPIO bit. After a power-on reset (POR) or any forced reset, all GPIO bits are set to 1, and the GPIO_n pins have a 48-kΩ input impedance to the IOV_{DD} pin (see Figure 59). The unused GPIO pins can be left floating.

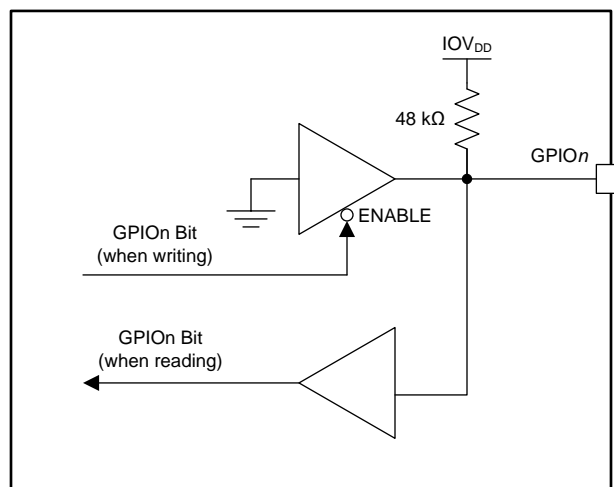

Figure 59. AMC7836 GPIO Pin

7.4 Device Functional Modes

The sixteen DACs in the AMC7836 device are split into four groups, each with four DACs. The output range and clamp voltage for each DAC group is set independently which enables the device to operate in one of the following modes:

- All-positive DAC range mode
- All-negative DAC range mode
- Mixed DAC range mode

7.4.1 All-Positive DAC Range Mode

In the AMC7836 all-positive DAC range mode, each of the four DAC groups is set to a positive voltage output range (0 to 5 V or 0 to 10 V).

Because the maximum DAC output for each group cannot exceed the common AV_{CC} voltage for the device ($AV_{CC} = AV_{CC_AB} = AV_{CC_CD}$), a DAC group in the 0 to 10 V output range forces the AV_{CC} voltage to a value greater or equal to 10 V even if the remaining DAC groups are set in the 0 to 5 V range. If all DAC groups are set in the 0 to 5 V range the AV_{CC} voltage can be set to a value as low as 5 V.

The minimum DAC output for each group cannot be lower than the AV_{SS} voltage but because the minimum DAC output is 0 V in the all-positive DAC range mode, all of the AV_{SS} pins (AV_{EE} , AV_{SSB} , AV_{SSC} , and AV_{SSD}) as well as the device thermal pad can be tied to AGND thus simplifying the board design. [Table 5](#) lists the typical configurations for this mode.

Table 5. All-positive DAC Range Mode Typical Configuration

PIN	NOTES	TYPICAL CONNECTION
AV_{DD}		5 V
DV_{DD}	DV_{DD} must be equal to AV_{DD} .	5 V
IOV_{DD}	IOV_{DD} must be equal to or less than DV_{DD} .	1.8 V to 5 V
AV_{CC_AB} , AV_{CC_CD}	The AV_{CC_AB} and AV_{CC_CD} pins must be tied to the same potential (AV_{CC}). AV_{CC} must be greater or equal than the maximum possible output voltage for any of the sixteen DACs.	$AV_{CC} \geq 5$ V $AV_{CC} \geq 10$ V
AV_{EE}		AGND
AV_{SSB} , AV_{SSC} , AV_{SSD}		AGND
Thermal Pad		AGND

After power-on or a reset event the output range for each DAC group is set automatically by the voltage present on the corresponding AV_{SS} pin. In the all-positive DAC range mode all AV_{SS} pins are connected to AGND and consequently all four DAC groups will initialize by default to the 0 to 5 V range. The output for any of the DAC groups can be modified to the 0 to 10 V range after initialization by setting the corresponding DAC range register (address 0x1E to 0x1F) to 110b.

In addition to setting the default output range, the AV_{SS} pins also set the clamp voltage for each DAC group. Because the clamp voltage is only dependent on the voltage in the AV_{SS} pin, changes to the DAC range registers do not affect the clamp setting. With the AV_{SS} pins connected to AGND, the clamp voltage for all sixteen DACs is 0 V.

7.4.2 All-Negative DAC Range Mode

In the AMC7836 all-negative DAC range mode, each of the four DAC groups is set to a negative voltage output range (–5 to 0 V or –10 to 0 V).

Although the maximum DAC output does not exceed 0 V, the common AV_{CC} voltage ($AV_{CC} = AV_{CC_AB} = AV_{CC_CD}$) must still satisfy a minimum voltage of 4.5 V to comply with the device operating conditions. In this case a recommended approach is to tie the AV_{CC} , AV_{DD} , and DV_{DD} supply pins to a common potential.

The minimum DAC output for each group cannot be lower than the voltage on the corresponding AV_{SS} pins (AV_{EE} , AV_{SSB} , AV_{SSC} , and AV_{SSD}). The AV_{SS} pins are not required to be tied to the same potential and typically the negative voltage at each AV_{SS} pin is dictated by the desired operating DAC negative output range. One exception is the AV_{EE} pin which must be the lowest potential in the device. The thermal pad should be either tied to the same potential as the AV_{EE} pin or left disconnected. [Table 6](#) lists the typical configurations for this mode.

Table 6. All-Negative DAC Range Mode Typical Configuration

PIN	NOTES	TYPICAL CONNECTION
AV_{DD}		5 V
DV_{DD}	DV_{DD} must be equal to AV_{DD} .	5 V
IOV_{DD}	IOV_{DD} must be equal to or less than DV_{DD} .	1.8 V to 5 V
AV_{CC_AB} , AV_{CC_CD}	The AV_{CC_AB} and AV_{CC_CD} pins must be tied to the same potential (AV_{CC}).	5 V
AV_{EE}	AV_{EE} must be the lowest potential in the device. AV_{EE} must be less than or equal to the minimum possible output voltage for DAC group A.	$AV_{EE} \leq -5$ V $AV_{EE} \leq -10$ V
AV_{SSB} , AV_{SSC} , AV_{SSD}	AV_{SSn} must be less than or equal to the minimum possible output voltage for DAC group n (n = B, C, D).	$AV_{EE} \leq AV_{SSn} \leq -5$ V $AV_{EE} \leq AV_{SSn} \leq -10$ V
Thermal Pad		AV_{EE} or, Floating

After power-on or a reset event the output range for each DAC group is set automatically by the voltage present in the corresponding AV_{SS} pin. In the all-negative DAC range mode all AV_{SS} pins should be connected to a voltage lower than AV_{SSTH} . If this condition is satisfied, all four DAC groups will initialize by default to the –10- to 0-V range. Because the negative clamp voltage is only dependent on the voltage in the AV_{SS} pin, the default –10- to 0-V output range presents no risk even when the AV_{SS} voltage is greater than –10 V. In this case the DAC group output should be modified to the –5 to 0 V range after initialization by setting the corresponding DAC range register (address 0x1E to 0x1F) to 101b.

7.4.3 Mixed DAC Range Mode

In the AMC7836 mixed DAC range mode, a combination of DAC groups is set to a negative voltage output range (–5 to 0 V or –10 to 0 V) and a positive voltage output range (0 to 5 V or 0 to 10 V).

Because the maximum DAC output for each group cannot exceed the common AV_{CC} voltage for the device ($AV_{CC} = AV_{CC_AB} = AV_{CC_CD}$), a DAC group in the 0 to 10 V output range forces the AV_{CC} voltage to a value greater or equal to 10 V. If all positive DAC groups are in the 0 to 5 V range the AV_{CC} voltage can be set to a value as low as 5 V.

The minimum DAC output for each group cannot be lower than the voltage on the corresponding AV_{SS} pins (AV_{EE} , AV_{SSB} , AV_{SSC} and AV_{SSD}). The AV_{SS} pins are not required to be tied to the same potential and typically the negative voltage at each AV_{SS} pin is dictated by the desired operating DAC negative output range. One exception is the AV_{EE} pin which must be the lowest potential in the device. The implication of this requirement is that if either DAC group B, C or D is set to a negative output range, DAC group A must also be set to a negative range. The thermal pad should be either tied to the same potential as the AV_{EE} pin or left disconnected. Table 7 lists the typical configurations for this mode.

Table 7. Mixed DAC Range Mode Typical Configuration

PIN	NOTES	TYPICAL CONNECTION	
AV_{DD}		5 V	
DV_{DD}	DV_{DD} must be equal to AV_{DD} .	5 V	
IOV_{DD}	IOV_{DD} must be equal to or less than DV_{DD} .	1.8 V to 5 V	
AV_{CC_AB} , AV_{CC_CD}	The AV_{CC_AB} and AV_{CC_CD} pins must be tied to the same potential (AV_{CC}). AV_{CC} must be greater or equal to the maximum possible output voltage for any of the positive output range DACs.	$AV_{CC} \geq 5$ V $AV_{CC} \geq 10$ V	
AV_{EE}	AV_{EE} must be the lowest potential in the device. AV_{EE} must be less than or equal to the minimum possible output voltage for DAC group A.	$AV_{EE} \leq -5$ V $AV_{EE} \leq -10$ V	
AV_{SSB} , AV_{SSC} , AV_{SSD}	AV_{SSn} must be less than or equal than the minimum possible output voltage for DAC group n (n = B, C, D).	Negative Range	$AV_{EE} \leq AV_{SSn} \leq -5$ V $AV_{EE} \leq AV_{SSn} \leq -10$ V
		Positive Range	AGND
Thermal Pad		AV_{EE} or, Floating	

After power-on or a reset event the output range for each DAC group is set automatically by the voltage present in the corresponding AV_{SS} pin. When the AV_{SS} voltage of a DAC group is lower than the threshold value, $AV_{SS_{TH}}$, the output for that DAC group is automatically configured to the –10 to 0 V range. Conversely, if the AV_{SS} voltage of the DAC group is higher than $AV_{SS_{TH}}$, the DAC-group output is automatically set to the 0 to 5 V range. The output for any of the DAC groups can be modified after initialization by setting the corresponding DAC range register (address 0x1E to 0x1F).

In addition to setting the default output range, the AV_{SS} pins also set the clamp voltage for each DAC group. Because the clamp voltage is only dependent on the voltage in the AV_{SS} pin, changes to the DAC range registers do not affect the clamp setting.

NOTE

Although not a recommended operating condition, the device allows a DAC group to operate in a positive output range even if the clamp voltage is negative (AV_{SS} connected to a negative supply voltage).

7.5 Programming

The AMC7836 device is controlled through a flexible four-wire serial interface that is compatible with SPI-type interfaces used on many microcontrollers and DSP controllers. The interface provides read and write (R/W) access to all registers of the AMC7836 device.

Each serial-interface access cycle is exactly $(N + 2)$ bytes long, where N is the number of data bytes. Asserting the \overline{CS} pin low initiates a frame. The frame ends when the \overline{CS} pin is deasserted high. In MSB-first mode, the first bit transferred is the R/W bit. The next 15 bits are the register address (32768 addressable registers), and the remaining bits are data. For all writes, data is committed in bytes as the eight data bit of a data field that is clocked in on the rising edge of SCLK. If the write access is not an even multiple of 8 clocks, the trailing data bits are not committed. On a read access, data is clocked out on the falling edge of the serial interface clock, SCLK, on the SDO pin.

Figure 60 and Figure 61 show the access protocol used by the interface.

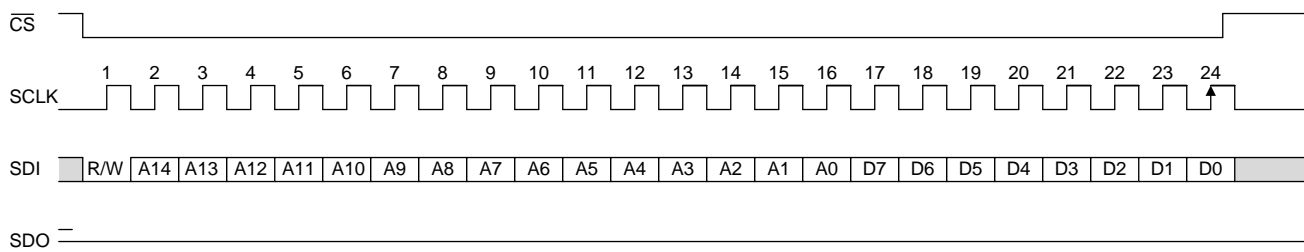

Figure 60. Serial Interface Write Bus Cycle

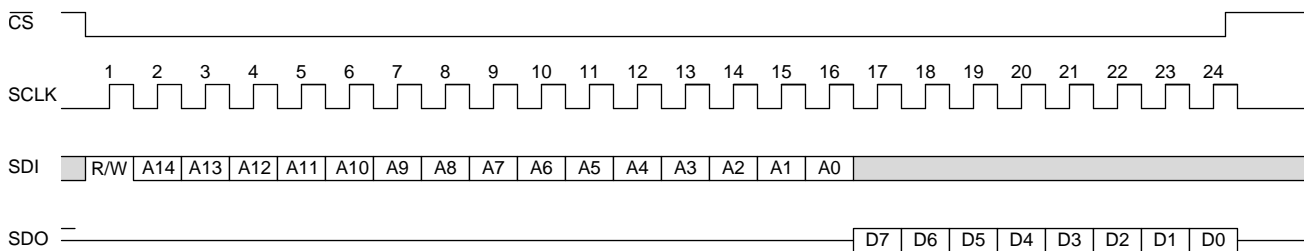

Figure 61. Serial Interface Read Bus Cycle

Streaming mode is supported for operations that require large amounts of data to be passed to or from the AMC7836. In streaming mode multiple bytes of data can be written to or read from the AMC7836 without specifically providing instructions for each byte. Streaming mode is implemented by continually holding the \overline{CS} pin active and continuing to shift new data in or old data out of the device.

The instruction phase includes the starting address. The AMC7836 device begins reading or writing data to this address and continues as long as the \overline{CS} pin is asserted and single byte writes have not been enabled in the interface configuration 1 register (address 0x01). The AMC7836 device automatically increments or decrements the address depending on the setting of the address ascension bit in the interface configuration 0 register (address 0x00).

If the address is decrementing and address 0x0000 is reached, the next address used is 0x7FFF. If the address is incrementing and address 0x7FFF is reached, the next address used is 0x0000. Care should be taken when writing to address 0x0000 and 0x0001 as writing to these addresses may change the configuration of the serial interface. Therefore address 0x0010 should be the first (ascending) or last (descending) address accessed in streaming mode.

Figure 62 and Figure 63 show the access protocol used in streaming mode.

Programming (continued)

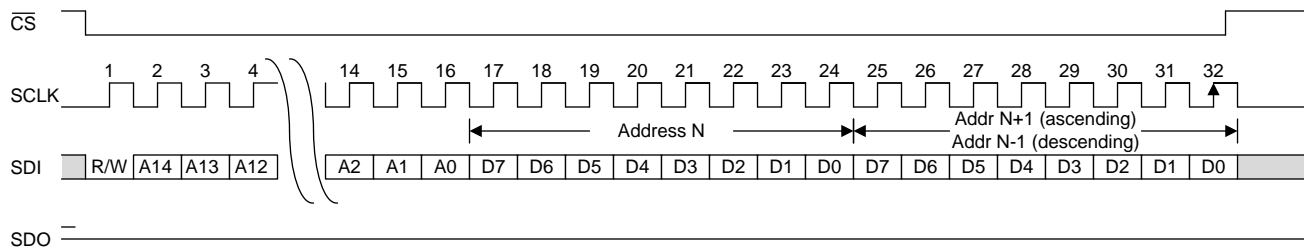

Figure 62. Serial Interface Streaming Write Example

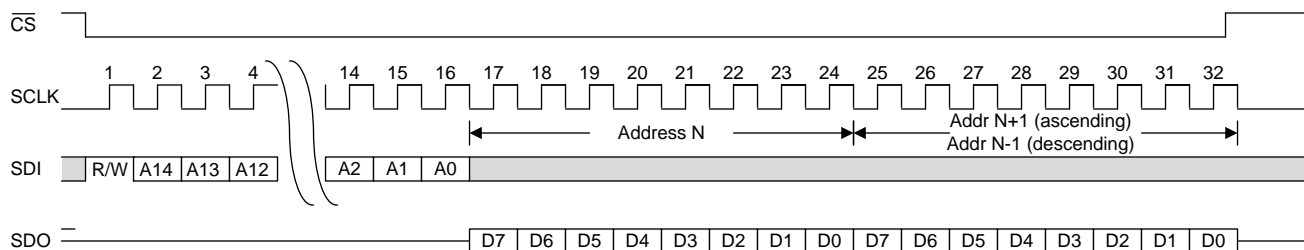

Figure 63. Serial Interface Streaming Read Example

7.6 Register Maps

Table 8. Register Map

ADDRESS	TYPE	DEFAULT	REGISTER NAME
0x00	R/W	30	Interface Configuration 0
0x01	R/W	00	Interface Configuration 1
0x02	R/W	03	Device Configuration
0x03	R	08	Chip Type
0x04	R	36	Chip ID (Low Byte)
0x05	R	0C	Chip ID (High Byte)
0x06	R	00	Chip Version
0x07 – 0x0B	—	—	Reserved
0x0C	R	51	Manufacturer ID (Low Byte)
0x0D	R	04	Manufacturer ID (High Byte)
0x0E	—	—	Reserved
0x0F	R/W	00	Register Update
0x10	R/W	00	ADC Configuration
0x11	R/W	70	False Alarm Configuration
0x12	R/W	00	GPIO Configuration
0x13	R/W	00	ADC MUX Configuration 0
0x14	R/W	00	ADC MUX Configuration 1
0x15	R/W	00	ADC MUX Configuration 2
0x16	—	—	Reserved
0x17	—	—	Reserved
0x18	R/W	00	DAC Clear Enable 0
0x19	R/W	00	DAC Clear Enable 1
0x1A	R/W	00	DAC Clear Source 0
0x1B	R/W	00	DAC Clear Source 1
0x1C	R/W	00	ALARMOUT Source0
0x1D	R/W	00	ALARMOUT Source1
0x1E	R/W	00	DAC Range 0
0x1F	R/W	00	DAC Range 1
0x20	R	00	ADC0-Data (Low Byte)
0x21	R	00	ADC0-Data (High Byte)
0x22	R	00	ADC1-Data (Low Byte)
0x23	R	00	ADC1-Data (High Byte)
0x24	R	00	ADC2-Data (Low Byte)
0x25	R	00	ADC2-Data (High Byte)
0x26	R	00	ADC3-Data (Low Byte)
0x27	R	00	ADC3-Data (High Byte)
0x28	R	00	ADC4-Data (Low Byte)
0x29	R	00	ADC4-Data (High Byte)
0x2A	R	00	ADC5-Data (Low Byte)
0x2B	R	00	ADC5-Data (High Byte)
0x2C	R	00	ADC6-Data (Low Byte)
0x2D	R	00	ADC6-Data (High Byte)
0x2E	R	00	ADC7-Data (Low Byte)
0x2F	R	00	ADC7-Data (High Byte)
0x30	R	00	ADC8-Data (Low Byte)

Table 8. Register Map (continued)

ADDRESS	TYPE	DEFAULT	REGISTER NAME
0x31	R	00	ADC8-Data (High Byte)
0x32	R	00	ADC9-Data (Low Byte)
0x33	R	00	ADC9-Data (High Byte)
0x34	R	00	ADC10-Data (Low Byte)
0x35	R	00	ADC10-Data (High Byte)
0x36	R	00	ADC11-Data (Low Byte)
0x37	R	00	ADC11-Data (High Byte)
0x38	R	00	ADC12-Data (Low Byte)
0x39	R	00	ADC12-Data (High Byte)
0x3A	R	00	ADC13-Data (Low Byte)
0x3B	R	00	ADC13-Data (High Byte)
0x3C	R	00	ADC14-Data (Low Byte)
0x3D	R	00	ADC14-Data (High Byte)
0x3E	R	00	ADC15-Data (Low Byte)
0x3F	R	00	ADC15-Data (High Byte)
0x40	R	00	ADC16-Data (Low Byte)
0x41	R	00	ADC16-Data (High Byte)
0x42	R	00	ADC17-Data (Low Byte)
0x43	R	00	ADC17-Data (High Byte)
0x44	R	00	ADC18-Data (Low Byte)
0x45	R	00	ADC18-Data (High Byte)
0x46	R	00	ADC19-Data (Low Byte)
0x47	R	00	ADC19-Data (High Byte)
0x48	R	00	ADC20-Data (Low Byte)
0x49	R	00	ADC20-Data (High Byte)
0x4A	R	00	Temperature Data (Low Byte)
0x4B	R	00	Temperature Data (High Byte)
0x4C - 0x4F	—	—	Reserved
0x50	R/W	00	DACA0-Data (Low Byte)
0x51	R/W	00	DACA0-Data (High Byte)
0x52	R/W	00	DACA1-Data (Low Byte)
0x53	R/W	00	DACA1-Data (High Byte)
0x54	R/W	00	DACA2-Data (Low Byte)
0x55	R/W	00	DACA2-Data (High Byte)
0x56	R/W	00	DACA3-Data (Low Byte)
0x57	R/W	00	DACA3-Data (High Byte)
0x58	R/W	00	DACB4-Data (Low Byte)
0x59	R/W	00	DACB4-Data (High Byte)
0x5A	R/W	00	DACB5-Data (Low Byte)
0x5B	R/W	00	DACB5-Data (High Byte)
0x5C	R/W	00	DACB6-Data (Low Byte)
0x5D	R/W	00	DACB6-Data (High Byte)
0x5E	R/W	00	DACB7-Data (Low Byte)
0x5F	R/W	00	DACB7-Data (High Byte)
0x60	R/W	00	DACC8-Data (Low Byte)
0x61	R/W	00	DACC8-Data (High Byte)
0x62	R/W	00	DACC9-Data (Low Byte)

Table 8. Register Map (continued)

ADDRESS	TYPE	DEFAULT	REGISTER NAME
0x63	R/W	00	DACC9-Data (High Byte)
0x64	R/W	00	DACC10-Data (Low Byte)
0x65	R/W	00	DACC10-Data (High Byte)
0x66	R/W	00	DACC11-Data (Low Byte)
0x67	R/W	00	DACC11-Data (High Byte)
0x68	R/W	00	DACD12-Data (Low Byte)
0x69	R/W	00	DACD12-Data (High Byte)
0x6A	R/W	00	DACD13-Data (Low Byte)
0x6B	R/W	00	DACD13-Data (High Byte)
0x6C	R/W	00	DACD14-Data (Low Byte)
0x6D	R/W	00	DACD14-Data (High Byte)
0x6E	R/W	00	DACD15-Data (Low Byte)
0x6F	R/W	00	DACD15-Data (High Byte)
0x70	R	00	Alarm Status 0
0x71	R	00	Alarm Status 1
0x72	R	0C	General Status
0x73 - 0x79	—	—	Reserved
0x7A	R/W	FF	GPIO
0x7B - 0x7F	—	—	Reserved
0x80	R/W	FF	ADC16-Upper-Thresh (Low Byte)
0x81	R/W	0F	ADC16-Upper-Thresh (High Byte)
0x82	R/W	00	ADC16-Lower-Thresh (Low Byte)
0x83	R/W	00	ADC16-Lower-Thresh (High Byte)
0x84	R/W	FF	ADC17-Upper-Thresh (Low Byte)
0x85	R/W	0F	ADC17-Upper-Thresh (High Byte)
0x86	R/W	00	ADC17-Lower-Thresh (Low Byte)
0x87	R/W	00	ADC17-Lower-Thresh (High Byte)
0x88	R/W	FF	ADC18-Upper-Thresh (Low Byte)
0x89	R/W	0F	ADC18-Upper-Thresh (High Byte)
0x8A	R/W	00	ADC18-Lower-Thresh (Low Byte)
0x8B	R/W	00	ADC18-Lower-Thresh (High Byte)
0x8C	R/W	FF	ADC19-Upper-Thresh (Low Byte)
0x8D	R/W	0F	ADC19-Upper-Thresh (High Byte)
0x8E	R/W	00	ADC19-Lower-Thresh (Low Byte)
0x8F	R/W	00	ADC19-Lower-Thresh (High Byte)
0x90	R/W	FF	ADC20-Upper-Thresh (Low Byte)
0x91	R/W	0F	ADC20-Upper-Thresh (High Byte)
0x92	R/W	00	ADC20-Lower-Thresh (Low Byte)
0x93	R/W	00	ADC20-Lower-Thresh (High Byte)
0x94	R/W	FF	LT-Upper-Thresh (Low Byte)
0x95	R/W	07	LT-Upper-Thresh (High Byte)
0x96	R/W	00	LT-Lower-Thresh (Low Byte)
0x97	R/W	08	LT-Lower-Thresh (High Byte)
0x98 - 0x9F	—	—	Reserved
0xA0	R/W	08	ADC16-Hysteresis
0xA1	R/W	08	ADC17-Hysteresis
0xA2	R/W	08	ADC18-Hysteresis

Table 8. Register Map (continued)

ADDRESS	TYPE	DEFAULT	REGISTER NAME
0xA3	R/W	08	ADC19-Hysteresis
0xA4	R/W	08	ADC20-Hysteresis
0xA5	R/W	08	LT-Hysteresis
0xA6 - 0xAF	—	—	Reserved
0xB0	R/W	00	DAC Clear 0
0xB1	R/W	00	DAC Clear 1
0xB2	R/W	00	Power-Down 0
0xB3	R/W	00	Power-Down 1
0xB4	R/W	00	Power-Down 2
0xB5 - 0xBF	—	—	Reserved
0xC0	R/W	00	ADC Trigger

7.6.1 Interface Configuration: Address 0x00 – 0x02
7.6.1.1 Interface Configuration 0 Register (address = 0x00) [reset = 0x30]
Figure 64. Interface Configuration 0 (Interface Config 0) Register (R/W)

7	6	5	4	3	2	1	0
SOFT-RESET	Reserved	ADDR-ASCEND	Reserved	Reserved			
R/W-0	R/W-0	R/W-1	R/W-1	R/W-All zeros			

Table 9. Interface Config 0 Register Field Descriptions (R/W)

Bit	Field	Type	Reset	Description
7	SOFT-RESET	R/W	0	Soft reset (self-clearing) 0: no action 1: reset – resets everything except address 0x00, 0x01
6	Reserved	R/W	0	Reserved for factory use
5	ADDR-ASCEND	R/W	1	Address Ascend 0: Descend – decrements address while streaming (address wrap from 0x0000 to 0x7FFF) 1: Ascend – increments address while streaming (address wrap from 0x7FFF to 0x0000)
4	Reserved	R/W	1	Reserved for factory use
3-0	Reserved	R/W	All zeros	Reserved for factory use

7.6.1.2 Interface Configuration 1 Register (address = 0x01) [reset = 0x00]
Figure 65. Interface Configuration 1 (Interface Config 1) Register (R/W)

7	6	5	4	3	2	1	0
SINGLE-INSTR	Reserved	READBACK	Reserved				
R/W-0	R/W-0	R/W-0	R/W-All zeros				

Table 10. Interface Config 1 Register Field Descriptions

Bit	Field	Type	Reset	Description
7	SINGLE-INSTR	R/W	0	Single instruction enable 0: streaming mode (default) 1: single instruction
6	Reserved	R/W	0	Reserved for factory use
5	READBACK	R/W	0	Read back 0: DAC read back from active registers (default) 1: DAC read back from buffer registers
4-0	Reserved	R/W	All zeros	Reserved for factory use

7.6.1.3 Device Configuration Register (address = 0x02) [reset = 0x03]
Figure 66. Device Configuration (Device Config) Register (R/W)

7	6	5	4	3	2	1	0
Reserved						POWER-MODE	
R/W-All Zeros						R/W-11	

Table 11. Device Config Register Field Descriptions

Bit	Field	Type	Reset	Description
7-2	Reserved	R/W	All zeros	Reserved for factory use
1-0	POWER-MODE	R/W	11	Mode: 00: Normal operation – full power and full performance 11: Power Down – lowest power, non-operational except SPI One time overwrite of the power-down registers (0xB2 and 0xB3)

7.6.2 Device Identification: Address 0x03 – 0x0D
7.6.2.1 Chip Type Register (address = 0x03) [reset = 0x08]
Figure 67. Chip Type Register (R)

7	6	5	4	3	2	1	0
Reserved				CHIP-TYPE			
R-0x0				R-0x8			

Table 12. Chip Type Register Field Descriptions

Bit	Field	Type	Reset	Description
7-4	Reserved	R	0x0	Reserved for factory use
3-0	CHIP-TYPE	R	0x8	Identifies the device as a precision analog monitor and control

7.6.2.2 Chip ID Low Byte Register (address = 0x04) [reset = 0x36]
Figure 68. Chip ID Low Byte Register (R)

7	6	5	4	3	2	1	0
CHIPID-LOW							
R-0x36							

Table 13. Chip ID Low Byte Register Field Descriptions

Bit	Field	Type	Reset	Description
7-0	CHIPID-LOW	R	0x36	Chip ID. Low byte

7.6.2.3 Chip ID High Byte Register (address = 0x05) [reset = 0x0C]
Figure 69. Chip ID High Byte Register (R)

7	6	5	4	3	2	1	0
CHIPID-HIGH							
R-0x0C							

Table 14. Chip ID High Byte Register Field Descriptions

Bit	Field	Type	Reset	Description
7-0	CHIPID-HIGH	R	0x0C	Chip ID. High byte

7.6.2.4 Version ID Register (address = 0x06) [reset = 0x00]
Figure 70. Version ID Register (R)

7	6	5	4	3	2	1	0
VERSIONID							
R-0x00							

Table 15. Version ID Register Field Descriptions

Bit	Field	Type	Reset	Description
7-0	VERSIONID	R	0x00	AMC7836 version ID. Subject to change

7.6.2.5 Manufacturer ID Low Byte Register (address = 0x0C) [reset = 0x51]
Figure 71. Manufacturer ID Low Byte Register (R)

7	6	5	4	3	2	1	0
VENDORID-LOW							
R-0x51							

Table 16. Manufacturer ID Low Byte Register Field Descriptions

Bit	Field	Type	Reset	Description
7-0	VENDORID-LOW	R	0x51	Manufacturer ID. Low byte

7.6.2.6 Manufacturer ID High Byte Register (address = 0x0D) [reset = 0x04]
Figure 72. Manufacturer ID High Byte Register

7	6	5	4	3	2	1	0
VENDORID-HIGH							
R-0x04							

Table 17. Manufacturer ID High Byte Register Field Descriptions

Bit	Field	Type	Reset	Description
7-0	VENDORID-HIGH	R	0x04	Manufacturer ID. High byte

7.6.3 Register Update (Buffered Registers): Address 0x0F
7.6.3.1 Register Update Register (address = 0x0F) [reset = 0x00]
Figure 73. Register Update Register (Self Clearing) [R/W]

7	6	5	4	3	2	1	0
Reserved			ADC-UPDATE	Reserved			UPDATE
R/W-All Zeros			R/W-0	R/W-All Zeros			R/W-0

Table 18. Register Update Register Field Descriptions

Bit	Field	Type	Reset	Description
7-5	Reserved	R/W	All zeros	Reserved for factory use
4	ADC-UPDATE	R/W	0	When set transfers the latest ADC and temperature conversion data to the ADC and Temperature Data registers. This function is needed when operating the ADC in auto-cycle mode
3-1	Reserved	R/W	All zeros	Reserved for factory use
0	DAC-UPDATE	R/W	0	DAC update (self clearing) 0: disabled 1: enabled – transfers data from buffers to active registers (DAC registers only)

7.6.4 General Device Configuration: Address 0x10 through 0x17

7.6.4.1 ADC Configuration Register (address = 0x10) [reset = 0x00]

Figure 74. ADC Configuration Register (R/W)

7	6	5	4	3	2	1	0
CMODE	CONV-RATE[1:0]		ADC-REF-BUFF	Reserved			
R/W-0	R/W-00		R/W-0	R/W-All zeros			

Table 19. ADC Configuration Register Field Descriptions

Bit	Field	Type	Reset	Description
7	CMODE	R/W	0	<p>ADC Conversion Mode Bit. This bit selects the ADC conversion mode.</p> <p>0: Direct mode. The analog inputs specified in the ADC channel registers are converted sequentially one time. When one set of conversions is complete, the ADC is idle and waits for a new trigger.</p> <p>1: Auto mode. The analog inputs specified in the AMC channel registers are converted sequentially and repeatedly. When one set of conversions is complete, the ADC multiplexer returns to the first channel and repeats the process. The ADC-UPDATE bit in register 0x0F must be used to initiate the transfer of the latest conversion data to the ADC Data registers.</p>
6-5	CONV-RATE[1:0]	R/W	00	ADC Conversion rate. See Table 20 to configure this setting.
4	ADC-REF-BUFF	R/W	0	<p>ADC Reference Buffer bit. This bit must be set to 1 after device power-up to enable the internal reference buffer driving the ADC.</p> <p>0: ADC reference buffer is disabled.</p> <p>1: ADC reference buffer is enabled.</p>
3-0	Reserved	R/W	All zeros	Reserved for factory use

Table 20. CONV-RATE[1:0] Bit Configuration

CONV-RATE[1:0]	Unipolar Channel Sample Time (µs)	Bipolar Channel Sample Time (µs)
00	11.5	34.5
01	23	34.5
10	34.5	34.5
11	69	69

7.6.4.2 False Alarm Configuration Register (address = 0x11) [reset = 0x70]
Figure 75. False Alarm Configuration Register (R/W)

7	6	5	4	3	2	1	0
CH-FALR-CT[2:0]			TEMP-FALR-CT[1:0]		Reserved		
R/W-011			R/W-10		R/W-All zeros		

Table 21. False Alarm Configuration Register Field Descriptions

Bit	Field	Type	Reset	Description
7-5	CH-FALR-CT[2:0]	R/W	011	False alarm protection for ADC channels. See Table 22 to configure this bit.
4-3	TEMP-FALR-CT[1:0]	R/W	10	False alarm protection for temperature sensor. See Table 23 to configure this bit.
2-0	Reserved	R/W	All zeros	Reserved for factory use

Table 22. CH-FALR-CT Bit Configuration

CH-FALR-CT	N Consecutive Samples Before Alarm is Set
000	1
001	4
010	8
011	16
100	32
101	64
110	128
111	256

Table 23. TEMP-FALR-CT Bit Configuration

TEMP-FALR-CT	N Consecutive Samples Before Alarm is Set
00	1
01	2
10	4
11	8

7.6.4.3 GPIO Configuration Register (address = 0x12) [reset = 0x00]
Figure 76. GPIO Configuration Register (R/W)

7	6	5	4	3	2	1	0
Reserved		Reserved		EN-DAV	EN-ADCTRIG	EN-ALARMOUT	EN-ALARMIN
R/W-All zeros		R/W-0		R/W-0	R/W-0	R/W-0	R/W-0

Table 24. GPIO Configuration Register Field Descriptions

Bit	Field	Type	Reset	Description
7-5	Reserved	R/W	All zeros	Reserved for factory use
4	Reserved	R/W	0	Reserved for factory use
3	EN-DAV	R/W	0	$\overline{\text{DAV}}$ pin enable 0: GPIO3 operation (default) 1: $\overline{\text{DAV}}$ operation
2	EN-ADCTRIG	R/W	0	$\overline{\text{ADCTRIG}}$ pin enable 0: GPIO2 operation (default) 1: $\overline{\text{ADCTRIG}}$ operation
1	EN-ALARMOUT	R/W	0	$\overline{\text{ALARMOUT}}$ pin enable 0: GPIO1 operation (default) 1: $\overline{\text{ALARMOUT}}$ operation
0	EN-ALARMIN	R/W	0	$\overline{\text{ALARMIN}}$ pin enable 0: GPIO0 operation (default) 1: $\overline{\text{ALARMIN}}$ operation

7.6.4.4 ADC MUX Configuration 0 Register (address = 0x13) [reset = 0x00]
Figure 77. ADC MUX Configuration 0 Register (R/W)

7	6	5	4	3	2	1	0
CH7	CH6	CH5	CH4	CH3	CH2	CH1	CH0
R/W-0	R/W-0	R/W-0	R/W-0	R/W-0	R/W-0	R/W-0	R/W-0

Table 25. ADC MUX Configuration 0 Register Field Descriptions

Bit	Field	Type	Reset	Description
7	CH7	R/W	0	When set to 1 the corresponding analog input channel ADC_n is accessed during an ADC conversion cycle. When cleared to 0 the corresponding input channel ADC_n is ignored during an ADC conversion cycle.
6	CH6	R/W	0	
5	CH5	R/W	0	
4	CH4	R/W	0	
3	CH3	R/W	0	
2	CH2	R/W	0	
1	CH1	R/W	0	
0	CH0	R/W	0	

7.6.4.5 ADC MUX Configuration 1 Register (address = 0x14) [reset = 0x00]
Figure 78. ADC MUX Configuration 1 Register (R/W)

7	6	5	4	3	2	1	0
CH15	CH14	CH13	CH12	CH11	CH10	CH9	CH8
R/W-0	R/W-0	R/W-0	R/W-0	R/W-0	R/W-0	R/W-0	R/W-0

Table 26. ADC MUX Configuration 1 Register Field Descriptions

Bit	Field	Type	Reset	Description
7	CH15	R/W	0	When set to 1 the corresponding analog input channel ADC_n is accessed during an ADC conversion cycle. When cleared to 0 the corresponding input channel ADC_n is ignored during an ADC conversion cycle.
6	CH14	R/W	0	
5	CH13	R/W	0	
4	CH12	R/W	0	
3	CH11	R/W	0	
2	CH10	R/W	0	
1	CH9	R/W	0	
0	CH8	R/W	0	

7.6.4.6 ADC MUX Configuration 2 Register (address = 0x15) [reset = 0x00]
Figure 79. ADC MUX Configuration 2 Register (R/W)

7	6	5	4	3	2	1	0
Reserved	TEMP-CH	CH20	CH19	CH18	CH17	CH16	
R/W-All Zeros	R/W-0	R/W-0	R/W-0	R/W-0	R/W-0	R/W-0	R/W-0

Table 27. ADC MUX Configuration 2 Register Field Descriptions

Bit	Field	Type	Reset	Description
7-6	Reserved	R/W	All Zeros	Reserved for factory use
5	TEMP-CH	R/W	0	When set to 1 the local temperature sensor is enabled for ADC conversion. When cleared to 0 the local temperature sensor is ignored.
4	CH20	R/W	0	When set to 1 the corresponding analog input channel ADC_n is accessed during an ADC conversion cycle. When cleared to 0 the corresponding input channel ADC_n is ignored during an ADC conversion cycle.
3	CH19	R/W	0	
2	CH18	R/W	0	
1	CH17	R/W	0	
0	CH16	R/W	0	

7.6.4.7 DAC Clear Enable 0 Register (address = 0x18) [reset = 0x00]
Figure 80. DAC Clear Enable 0 Register (R/W)

7	6	5	4	3	2	1	0
CLREN-B7	CLREN-B6	CLREN-B5	CLREN-B4	CLREN-A3	CLREN-A2	CLREN-A1	CLREN-A0
R/W-0	R/W-0	R/W-0	R/W-0	R/W-0	R/W-0	R/W-0	R/W-0

Table 28. DAC Clear Enable 0 Register Field Descriptions

Bit	Field	Type	Reset	Description
7	CLREN-B7	R/W	0	This register determines which DACs go into clear state when a clear event is detected as configured in the DAC-CLEAR-SOURCE registers. If CLREN _n = 1, DAC _n is forced into a clear state with a clear event. If CLREN _n = 0, a clear event does not affect the state of DAC _n .
6	CLREN-B6	R/W	0	
5	CLREN-B5	R/W	0	
4	CLREN-B4	R/W	0	
3	CLREN-A3	R/W	0	
2	CLREN-A2	R/W	0	
1	CLREN-A1	R/W	0	
0	CLREN-A0	R/W	0	

7.6.4.8 DAC Clear Enable 1 Register (address = 0x19) [reset = 0x00]
Figure 81. DAC Clear Enable 1 Register (R/W)

7	6	5	4	3	2	1	0
CLREN-D15	CLREN-D14	CLREN-D13	CLREN-D12	CLREN-C11	CLREN-C10	CLREN-C9	CLREN-C8
R/W-0	R/W-0	R/W-0	R/W-0	R/W-0	R/W-0	R/W-0	R/W-0

Table 29. DAC Clear Enable 1 Register Field Descriptions

Bit	Field	Type	Reset	Description
7	CLREN-D15	R/W	0	This register determines which DACs go into clear state when a clear event is detected as configured in the DAC-CLEAR-SOURCE registers. If CLREN _n = 1, DAC _n is forced into a clear state with a clear event. If CLREN _n = 0, a clear event does not affect the state of DAC _n .
6	CLREN-D14	R/W	0	
5	CLREN-D13	R/W	0	
4	CLREN-D12	R/W	0	
3	CLREN-C11	R/W	0	
2	CLREN-C10	R/W	0	
1	CLREN-C9	R/W	0	
0	CLREN-C8	R/W	0	

7.6.5 DAC Clear and ALARMOUT Source Select: Address 0x1A through 0x1D

7.6.5.1 DAC Clear Source 0 Register (address = 0x1A) [reset = 0x00]

Figure 82. DAC Clear Source 0 Register (R/W)

7	6	5	4	3	2	1	0
Reserved			ADC20-ALR-CLR	ADC19-ALR-CLR	ADC18-ALR-CLR	ADC17-ALR-CLR	ADC16-ALR-CLR
R/W-All zeros			R/W-0	R/W-0	R/W-0	R/W-0	R/W-0

Table 30. DAC Clear Source 0 Register Field Descriptions

Bit	Field	Type	Reset	Description
7-5	Reserved	R/W	All zeros	Reserved for factory use
4	ADC20-ALR-CLR	R/W	0	This register selects which alarm forces DACs into a clear state, regardless of which DAC operation mode is active, auto or manual. In order for DAC _n to go into clear mode, it must be enabled in the DAC Clear Enable registers.
3	ADC19-ALR-CLR	R/W	0	
2	ADC18-ALR-CLR	R/W	0	
1	ADC17-ALR-CLR	R/W	0	
0	ADC16-ALR-CLR	R/W	0	

7.6.5.2 DAC Clear Source 1 Register (address = 0x1B) [reset = 0x00]

Figure 83. DAC Clear Source 1 Register (R/W)

7	6	5	4	3	2	1	0
Reserved				ALARMIN-ALR	THERM-ALR	LT-HIGH-ALR	LT-LOW-ALR
R/W-All zeros				R/W-0	R/W-0	R/W-0	R/W-0

Table 31. DAC Clear Source 1 Register Field Descriptions

Bit	Field	Type	Reset	Description
7-4	Reserved	R/W	All zeros	Reserved for factory use
3	ALARMIN-ALR	R/W	0	This register selects which alarm forces DACs into a clear state, regardless of which DAC operation mode is active, auto or manual. In order for DAC _n to go into clear mode, it must be enabled in the DAC Clear Enable registers.
2	THERM-ALR	R/W	0	
1	LT-HIGH-ALR	R/W	0	
0	LT-LOW-ALR	R/W	0	

7.6.5.3 ALARMOUT Source 0 Register (address = 0x1c) [reset = 0x00]

Figure 84. ALARMOUT Source 0 Register (R/W)

7	6	5	4	3	2	1	0
Reserved			ADC20-ALR-OUT	ADC19-ALR-OUT	ADC18-ALR-OUT	ADC17-ALR-OUT	ADC16-ALR-OUT
R/W-All zeros			R/W-0	R/W-0	R/W-0	R/W-0	R/W-0

Table 32. ALARMOUT Source 0 Register Field Descriptions

Bit	Field	Type	Reset	Description
7-5	Reserved	R/W	All zeros	Reserved for factory use
4	ADC20-ALR-OUT	R/W	0	This register selects which alarms can activate the $\overline{\text{ALARMOUT}}$ pin. The $\overline{\text{ALARMOUT}}$ must be enabled for this function to take effect.
3	ADC19-ALR-OUT	R/W	0	
2	ADC18-ALR-OUT	R/W	0	
1	ADC17-ALR-OUT	R/W	0	
0	ADC16-ALR-OUT	R/W	0	

7.6.5.4 ALARMOUT Source 1 Register (address = 0x1D) [reset = 0x00]
Figure 85. ALARMOUT Source 1 Register (R/W)

7	6	5	4	3	2	1	0
Reserved			ALARM-LATCH-DIS	ALRIN-ALR-OUT	THERM-ALR-OUT	LT-HIGH-ALR-OUT	LT-LOW-ALR-OUT
R/W-All zeros			R/W-0	R/W-0	R/W-0	R/W-0	R/W-0

Table 33. ALARMOUT Source 1 Register Field Descriptions

Bit	Field	Type	Reset	Description
7-5	Reserved	R/W	All zeros	Reserved for factory use
4	ALARM-LATCH-DIS	R/W	0	Alarm latch disable bit. When cleared to 0 the alarm bits are latched. When an alarm occurs, the corresponding alarm bit is set to "1". The alarm bit remains until the error condition subsides and the alarm register is read. Before reading, the alarm bit is not cleared even if the alarm condition disappears. When set to 1 the alarm bits are not latched. When the alarm condition subsides, the alarm bits are cleared regardless of whether the alarm bits have been read or not.
3	ALRIN-ALR-OUT	R/W	0	This register selects which alarms can activate the <u>ALARMOUT</u> pin. The <u>ALARMOUT</u> must be enabled for this function to take effect.
2	THERM-ALR-OUT	R/W	0	
1	LT-HIGH-ALR-OUT	R/W	0	
0	LT-LOW-ALR-OUT	R/W	0	

7.6.6 DAC Range: Address 0x1E
7.6.6.1 DAC Range Register (address = 0x1E) [reset = 0x00]
Figure 86. DAC Range Register (R/W)

7	6	5	4	3	2	1	0
Reserved	DAC-RANGEB[2:0]			Reserved	DAC-RANGEA[2:0]		
R/W-0	R/W-All zeros			R/W-0	R/W-All zeros		

Table 34. DAC Range Register Field Descriptions

Bit	Field	Type	Reset	Description
7	Reserved	R/W	0	Reserved for factory use
6-4	DAC-RANGEB[2:0]	R/W	All zeros	DAC group B output voltage selection. Overrides output range set by the auto-range detection circuit. See Table 35 to configure this setting.
3	Reserved	R/W	0	Reserved for factory use
2	DAC-RANGEA[2:0]	R/W	All zeros	DAC group A output voltage selection. Overrides output range set by the auto-range detection circuit. See Table 35 to configure this setting.

Table 35. DAC-RANGEx Bit Configuration

DAC-RANGEx[2:0]	DAC Group x Output Voltage Range
0xx	Range set by auto-range detection circuit
100	-10 to 0 V
101	-5 to 0 V
110	0 to 10 V
111	0 to 5 V

7.6.6.2 DAC Range 1 Register (address = 0x1F) [reset = 0x00]

Figure 87. DAC Range 1 Register (R/W)

7	6	5	4	3	2	1	0
Reserved		DAC-RANGED[2:0]		Reserved		DAC-RANGEC[2:0]	
R/W-0		R/W-All zeros		R/W-0		R/W-All zeros	

Table 36. DAC Range 1 Register Field Descriptions

Bit	Field	Type	Reset	Description
7	Reserved	R/W	0	Reserved for factory use
6-4	DAC-RANGED[2:0]	R/W	All zeros	DAC group D output voltage selection. Overrides output range set by the auto-range detection circuit. See Table 35 to configure this setting.
3	Reserved	R/W	0	Reserved for factory use
2	DAC-RANGEC[2:0]	R/W	All zeros	DAC group C output voltage selection. Overrides output range set by the auto-range detection circuit. See Table 35 to configure this setting.

7.6.7 ADC and Temperature Data: Address 0x20 through 0x4B

7.6.7.1 ADCn-Data (Low Byte) Register (address = 0x20 through 0x49) [reset = 0x00]

Figure 88. ADCn-Data (Low Byte) Register (R)

7	6	5	4	3	2	1	0
ADCn-DATA(7:0)							
R-All zeros							

Table 37. ADCn-Data (Low Byte) Register Field Descriptions

Bit	Field	Type	Reset	Description
7-0	ADCn-DATA(7:0)	R	All zeros	Stores the 12-bit ADC _n conversion results in straight binary format for both types of inputs channels (unipolar and bipolar)

7.6.7.2 ADCn-Data (High Byte) Register (address = 0x20 through 0x49) [reset = 0x00]

Figure 89. ADCn-Data (High Byte) Register (R)

7	6	5	4	3	2	1	0
Reserved				ADCn-DATA (11:8)			
R-All zeros				R-All zeros			

Table 38. ADCn-Data (High Byte) Register Field Descriptions

Bit	Field	Type	Reset	Description
7-4	Reserved	R	All zeros	Reserved for factory use
3-0	ADCn-DATA (11:8)	R	All zeros	Stores the 12-bit ADC _n conversion results in straight binary format for both types of inputs channels (unipolar and bipolar).

7.6.7.3 Temperature Data (Low Byte) Register (address = 0x4A) [reset = 0x00]
Figure 90. Temperature Data (Low Byte) Register (R)

7	6	5	4	3	2	1	0
TEMP-DATA(7:0)							
R-All zeros							

Table 39. Temperature Data (Low Byte) Register Field Descriptions

Bit	Field	Type	Reset	Description
7-0	TEMP-DATA(7:0)	R	All zeros	Stores the temperature sensor reading in twos complement format.

7.6.7.4 Temperature Data (High Byte) Register (address = 0x4B) [reset = 0x00]
Figure 91. Temperature Data (High Byte) Register (R)

7	6	5	4	3	2	1	0
Reserved				TEMP-DATA(11:8)			
R-All zeros				R-All zeros			

Table 40. Temperature Data (High Byte) Register Field Descriptions

Bit	Field	Type	Reset	Description
7-4	Reserved	R	All zeros	Reserved for factory use.
3-0	TEMP-DATA(11:8)	R	All zeros	Stores the temperature sensor reading in twos complement format.

7.6.8 DAC Data: Address 0x50 through 0x6F
7.6.8.1 DACn-Data (Low Byte) Register (address = 0x50 through 0x6F) [reset = 0x00]
Figure 92. DACn-Data (Low Byte) Register (R/W)

7	6	5	4	3	2	1	0
DACn-DATA (7:0)							
R/W-All zeros							

Table 41. DACn-Data (Low Byte) Register Field Descriptions

Bit	Field	Type	Reset	Description
7-0	DACn-DATA (7:0)	R/W	All zeros	Stores the 12-bit data to be loaded to the DAC_n latches in straight binary format. The straight binary format is used for all DAC ranges.

7.6.8.2 DACn Data (High Byte) Register (address = 0x50 through 0x6F) [reset = 0x00]
Figure 93. DACn Data (High Byte) Register (R/W)

7	6	5	4	3	2	1	0
Reserved				DACn-DATA (11:8)			
R/W-All zeros				R/W-All zeros			

Table 42. DACn Data (High Byte) Register Field Descriptions

Bit	Field	Type	Reset	Description
7-4	Reserved	R/W	All zeros	Reserved for factory use
3-0	DACn-DATA (11:8)	R/W	All zeros	Stores the 12-bit data to be loaded to the DAC_n latches in straight binary format. The straight binary format is used for all DAC ranges.

7.6.9 Status Registers: Address 0x70 through 0x72

The AMC7836 device continuously monitors all general purpose analog inputs and local temperature sensor during normal operation. When any input is out of the specified range N consecutive times, the corresponding alarm bit is set (1). If the input returns to the normal range before N consecutive times, the corresponding alarm bit remains clear (0). This configuration avoids any false alarms. When an alarm status occurs, the corresponding alarm bit is set (1). When the corresponding bit in the ALARMOUT Source Registers is cleared (0), the ALARMOUT pin is latched.

Whenever an alarm status bit is set, it remains set until the event that caused it is resolved and its status register is read. Reading the Alarm Status Registers clears the alarm status bits. The alarm bit can only be cleared by reading its Alarm Status register after the event is resolved, or by hardware reset, software reset, or power-on reset. All alarm status bits are cleared when reading the Alarm Status registers, and all these bits are reasserted if the out-of-limit condition still exists after the next conversion cycle, unless otherwise noted.

7.6.9.1 Alarm Status 0 Register (address = 0x70) [reset = 0x00]

Figure 94. Alarm Status 0 Register (R)

7	6	5	4	3	2	1	0
Reserved			ADC20-ALR	ADC19-ALR	ADC18-ALR	ADC17-ALR	ADC16-ALR
R-All zeros			R-0	R-0	R-0	R-0	R-0

Table 43. Alarm Status 0 Register Field Descriptions

Bit	Field	Type	Reset	Description
7-5	Reserved	R	All zeros	Reserved for factory use
4	ADC20-ALR	R	0	ADC20-ALR = 1 when ADC20 is out of the range defined by the corresponding threshold registers. ADC20-ALR = 0 when the analog input is not out of the specified range.
3	ADC19-ALR	R	0	ADC19-ALR = 1 when ADC19 is out of the range defined by the corresponding threshold registers. ADC19-ALR = 0 when the analog input is not out of the specified range.
2	ADC18-ALR	R	0	ADC18-ALR = 1 when ADC18 is out of the range defined by the corresponding threshold registers. ADC18-ALR = 0 when the analog input is not out of the specified range.
1	ADC17-ALR	R	0	ADC17-ALR = 1 when ADC17 is out of the range defined by the corresponding threshold registers. ADC17-ALR = 0 when the analog input is not out of the specified range.
0	ADC16-ALR	R	0	ADC16-ALR = 1 when ADC16 is out of the range defined by the corresponding threshold registers. ADC16-ALR = 0 when the analog input is not out of the specified range.

7.6.9.2 Alarm Status 1 Register (address = 0x71) [reset = 0x00]

Figure 95. Alarm Status 1 Register (R)

7	6	5	4	3	2	1	0
Reserved				ALARMIN-ALR	THERM-ALR	LT-HIGH-ALR	LT-LOW-ALR
R-All zeros				R-0	R-0	R-0	R-0

Table 44. Alarm Status 1 Register Field Descriptions

Bit	Field	Type	Reset	Description
7-4	Reserved	R	All zeros	Reserved for factory use
3	ALARMIN-ALR	R	0	The ALARMIN-ALR is set to 1 if the $\overline{\text{ALARMIN}}$ pin is enabled and set high.
2	THERM-ALR	R	0	Thermal alarm flag. When the die temperature is equal to or greater than +150°C, the bit is set (1) and the THERM-ALR flag activates. The on-chip temperature sensor (LT) monitors the die temperature. If LT is disabled, the THERM-ALR bit is always 0. The hysteresis of this alarm is 8°C.
1	LT-HIGH-ALR	R	0	LT-HIGH-ALR = 1 when the temperature sensor is out of the range defined by the upper threshold.
0	LT-LOW-ALR	R	0	LT-LOW-ALR = 1 when the temperature sensor is out of the range defined by the lower threshold.

7.6.9.3 General Status Register (address = 0x72) [reset = 0x0C]
Figure 96. General Status Register (R)

7	6	5	4	3	2	1	0
AVSSD	AVSSC	AVSSB	AVSSA	ADC_IDLE	Reserved	GALR	DAVF
—	—	—	—	R-1	R-1	R-0	R-0

Table 45. General Status Register Field Descriptions

Bit	Field	Type	Reset	Description
7	AVSSD		—	This bit is the auto-range detection output for DAC group D. This bit is set to 1 when $AV_{SSD} < AV_{SSTH}$ (–10- to 0-V output range), and 0 when $AV_{SSD} > AV_{SSTH}$ (0- to 5-V output range).
6	AVSSC		—	This bit is the auto-range detection output for DAC group C. This bit is set to 1 when $AV_{SSC} < AV_{SSTH}$ (–10- to 0-V output range), and 0 when $AV_{SSC} > AV_{SSTH}$ (0- to 5-V output range).
5	AVSSB		—	This bit is the auto-range detection output for DAC group B. This bit is set to 1 when $AV_{SSB} < AV_{SSTH}$ (–10- to 0-V output range), and 0 when $AV_{SSB} > AV_{SSTH}$ (0- to 5-V output range).
4	AVSSA		—	This bit is the auto-range detection output for DAC group A. This bit is set to 1 when $AV_{EE} < AV_{SSTH}$ (–10- to 0-V output range), and 0 when $AV_{EE} > AV_{SSTH}$ (0- to 5-V output range).
3	ADC_IDLE	R	1	ADC Idle indicator. Auto mode: 1 by default; goes to 0 once the ADC is triggered and is running. Remains 0 until ADC is stopped, then ADC_IDLE returns to 1. Direct mode: 1 by default; goes to 0 once the ADC is triggered and direct conversions are running and returns to 1 when direct mode conversions are completed.
2	Reserved	R	1	Reserved for factory use
1	GALR	R	0	Global alarm bit. This bit is the OR function of all individual alarm bits of the status register. This bit is set to 1 when any alarm condition occurs and remains set until the status register is read. This bit is cleared after reading the Status Register.
0	DAVF	R	0	ADC Data available flag bit. Direct mode only. Always cleared in Auto mode. 0: ADC conversion is in progress or ADC is in Auto mode 1: ADC conversions are complete and new data is available

7.6.10 GPIO: Address 0x7A

7.6.10.1 GPIO Register (address = 0x7A) [reset = 0xFF]

Figure 97. GPIO Register (R/W)

7	6	5	4	3	2	1	0
GPIO-7	GPIO-6	GPIO-5	GPIO-4	GPIO-3	GPIO-2	GPIO-1	GPIO-0
R/W-1	R/W-1	R/W-1	R/W-1	R/W-1	R/W-1	R/W-1	R/W-1

Table 46. GPIO Register Field Descriptions

Bit	Field	Type	Reset	Description
7	GPIO-7	R/W	1	For write operation the GPIO pin operates as an output. Writing a 1 to the GPIO-n bit sets the GPIO-N pin to high impedance. Writing a 0 sets the GPIO-n pin to logic low. For read operations the GPIO pin operates as an input. Read the GPIO-n bit to receive the status of the GPIO-n pin. The GPIO-n pin has 48-kΩ input impedance to IOV _{DD} .
6	GPIO-6	R/W	1	
5	GPIO-5	R/W	1	
4	GPIO-4	R/W	1	
3	GPIO-3	R/W	1	
2	GPIO-2	R/W	1	
1	GPIO-1	R/W	1	
0	GPIO-0	R/W	1	

7.6.11 Out-Of-Range ADC Thresholds: Address 0x80 through 0x93

The unipolar analog inputs (LV_ADC16 to LV_ADC20) and the local temperature sensor implement an out-of-range alarm function. The Upper-Thresh and Lower-Thresh registers define the upper bound and lower bounds for these inputs. This window determines whether the analog input or temperature is out-of-range. When the input is outside the window, the corresponding CH-ALR-n bit in the Status Register is set to 1. For normal operation, the value of the upper threshold must be greater than the value of lower threshold; otherwise, an alarm is always indicated. The analog input threshold values are specified in straight binary format while the local temperature ones are specified in two's complement format.

7.6.11.1 ADC_n-Upper-Thresh (Low Byte) Register (address = 0x80 through 0x93) [reset = 0xFF]

Figure 98. ADC_n-Upper-Thresh (Low Byte) Register (R/W)

7	6	5	4	3	2	1	0
THRU _n (7:0)							
R/W-All ones							

Table 47. ADC_n-Upper-Thresh (Low Byte) Register Field Descriptions

Bit	Field	Type	Reset	Description
7-0	THRU _n (7:0)	R/W	All ones	Sets 12-bit upper threshold value for the ADC _n channel in straight binary format.

7.6.11.2 ADC_n-Upper-Threshold (High Byte) Register (address = 0x80 through 0x93) [reset = 0x0F]
Figure 99. ADC_n-Upper-Threshold (High Byte) Register (R/W)

7	6	5	4	3	2	1	0
Reserved				THRU _n (11:8)			
R/W-All zeros				R/W-0xF			

Table 48. ADC_n-Upper-Threshold (High Byte) Register Field Descriptions

Bit	Field	Type	Reset	Description
7-4	Reserved	R/W	All zeros	Reserved for factory use.
3-0	THRU _n (11:8)	R/W	0xF	Sets 12-bit upper threshold value for the ADC _n channel in straight binary format.

7.6.11.3 ADC_n-Lower-Threshold (Low Byte) Register (address = 0x80 through 0x93) [reset = 0x00]
Figure 100. ADC_n-Lower-Threshold (Low Byte) Register (R/W)

7	6	5	4	3	2	1	0
THRL _n (7:0)							
R/W-All zeros							

Table 49. ADC_n-Lower-Threshold (Low Byte) Register Field Descriptions

Bit	Field	Type	Reset	Description
7-0	THRL _n (7:0)	R/W	All zeros	Sets 12-bit lower threshold value for the ADC _n channel in straight binary format.

7.6.11.4 ADC_n-Lower-Threshold (High Byte) Register (address = 0x80 through 0x93) [reset = 0x00]
Figure 101. ADC_n-Lower-Threshold (High Byte) Register (R/W)

7	6	5	4	3	2	1	0
Reserved				THRL _n (11:8)			
R/W-All zeros				R/W-All zeros			

Table 50. ADC_n-Lower-Threshold (High Byte) Register Field Descriptions Field Descriptions

Bit	Field	Type	Reset	Description
7-4	Reserved	R/W	All zeros	Reserved for factory use.
3-0	THRL _n (11:8)	R/W	All zeros	Sets 12-bit lower threshold value for ADC _n channel in straight binary format.

7.6.11.5 LT-Upper-Threshold (Low Byte) Register (address = 0x94) [reset = 0xFF]
Figure 102. LT-Upper-Threshold (Low Byte) Register (R/W)

7	6	5	4	3	2	1	0
THRU-LT(7:0)							
R/W-All ones							

Table 51. LT-Upper-Threshold (Low Byte) Register Field Descriptions

Bit	Field	Type	Reset	Description
7-0	THRU-LT(7:0)	R/W	All ones	Sets 12-bit upper threshold value for the local temperature sensor in two's complement format.

7.6.11.6 LT-Upper-Thresh (High Byte) Register (address = 0x95) [reset = 0x07]
Figure 103. LT-Upper-Thresh (High Byte) Register (R/W)

7	6	5	4	3	2	1	0
Reserved				THRU-LT(11:8)			
R/W-All zeros				R/W-0x7			

Table 52. LT-Upper-Thresh (High Byte) Register Field Descriptions

Bit	Field	Type	Reset	Description
7-4	Reserved	R/W	All zeros	Reserved for factory use.
3-0	THRU-LT(11:8)	R/W	0x7	Sets 12-bit upper threshold value for the local temperature sensor in two's complement format.

7.6.11.7 LT-Lower-Thresh (Low Byte) Register (address = 0x96) [reset = 0x00]
Figure 104. LT-Lower-Thresh (Low Byte) Register (R/W)

7	6	5	4	3	2	1	0
THRL-LT(7:0)							
R/W-All zeros							

Table 53. LT-Lower-Thresh (Low Byte) Register Field Descriptions

Bit	Field	Type	Reset	Description
7-0	THRL-LT(7:0)	R/W	All zeros	Sets 12-bit lower threshold value for the local temperature sensor in two's complement format.

7.6.11.8 LT-Lower-Thresh (High Byte) Register (address = 0x97) [reset = 0x08]
Figure 105. LT-Lower-Thresh (High Byte) Register (R/W)

7	6	5	4	3	2	1	0
Reserved				THRL-LT(11:8)			
R/W-All zeros				R/W-0x8			

Table 54. LT-Lower-Thresh (High Byte) Register Field Descriptions

Bit	Field	Type	Reset	Description
7-4	Reserved	R/W	All zeros	Reserved for factory use.
3-0	THRL-LT(11:8)	R/W	0x8	Sets 12-bit lower threshold value for the local temperature sensor in two's complement format.

7.6.12 Alarm Hysteresis Configuration: Address 0xA0 and 0xA5

The hysteresis registers define the hysteresis in the out-of-range alarms.

7.6.12.1 ADC_n-Hysteresis Register (address = 0xA0 through 0xA4) [reset = 0x08]

Figure 106. ADC_n-Hysteresis Register (R/W)

7	6	5	4	3	2	1	0
Reserved	HYST _n (6:0)						
R/W-0	R/W-0x08						

Table 55. ADC_n-Hysteresis Register Field Descriptions

Bit	Field	Type	Reset	Description
7	Reserved	R/W	0	Reserved for factory use.
6-0	HYST _n (6:0)	R/W	0x08	Hysteresis of general purpose ADC _n , 1 LSB per step

7.6.12.2 LT-Hysteresis Register (address = 0xA5) [reset = 0x08]

Figure 107. LT-Hysteresis Register (R/W)

7	6	5	4	3	2	1	0
Reserved			HYST-LT(4:0)				
R/W-All zeros			R/W-0x08				

Table 56. LT-Hysteresis Register Field Descriptions

Bit	Field	Type	Reset	Description
7-5	Reserved	R/W	All zeros	Reserved for factory use.
4-0	HYST-LT(4:0)	R/W	0x08	Hysteresis of local temperature sensor, 1°C per step. The range is 0°C to 31°C.

7.6.13 Clear and Power-Down Registers: Address 0xB0 through 0xB4

7.6.13.1 DAC Clear 0 Register (address = 0xB0) [reset = 0x00]

Figure 108. DAC Clear 0 Register (R/W)

7	6	5	4	3	2	1	0
CLR-B7	CLR-B6	CLR-B5	CLR-B4	CLR-A3	CLR-A2	CLR-A1	CLR-A0
R/W-0	R/W-0	R/W-0	R/W-0	R/W-0	R/W-0	R/W-0	R/W-0

Table 57. DAC Clear 0 Register Field Descriptions

Bit	Field	Type	Reset	Description
7	CLR-B7	R/W	0	This register uses software to force the DAC into a clear state. If CLR _n = 1, DAC _n is forced into a clear state. If CLR _n = 0, DAC _n is restored to normal operation.
6	CLR-B6	R/W	0	
5	CLR-B5	R/W	0	
4	CLR-B4	R/W	0	
3	CLR-A3	R/W	0	
2	CLR-A2	R/W	0	
1	CLR-A1	R/W	0	
0	CLR-A0	R/W	0	

7.6.13.2 DAC Clear 1 Register (address = 0xB1) [reset = 0x00]
Figure 109. DAC Clear 1 Register (R/W)

7	6	5	4	3	2	1	0
CLR-D15	CLR-D14	CLR-D13	CLR-D12	CLR-C11	CLR-C10	CLR-C9	CLR-C8
R/W-0	R/W-0	R/W-0	R/W-0	R/W-0	R/W-0	R/W-0	R/W-0

Table 58. DAC Clear 1 Register Field Descriptions

Bit	Field	Type	Reset	Description
7	CLR-D15	R/W	0	This register uses software to force the DAC into a clear state. If CLR _n = 1, DAC _n is forced into a clear state. If CLR _n = 0, DAC _n is restored to normal operation.
6	CLR-D14	R/W	0	
5	CLR-D13	R/W	0	
4	CLR-D12	R/W	0	
3	CLR-C11	R/W	0	
2	CLR-C10	R/W	0	
1	CLR-C9	R/W	0	
0	CLR-C8	R/W	0	

7.6.13.3 Power-Down 0 Register (address = 0xB2) [reset = 0x00]
Figure 110. Power-Down 0 Register (R/W)

7	6	5	4	3	2	1	0
PDAC-B7	PDAC-B6	PDAC-B5	PDAC-B4	PDAC-A3	PDAC-A2	PDAC-A1	PDAC-A0
R/W-0	R/W-0	R/W-0	R/W-0	R/W-0	R/W-0	R/W-0	R/W-0

Table 59. Power-Down 0 Register Field Descriptions

Bit	Field	Type	Reset	Description
7	PDAC-B7	R/W	0	After power-on or reset, all bits in the power-down register are cleared to 0, and all the components controlled by this register are either powered-down or off. The power-down register allows the host to manage the AMC7836 power dissipation. When not required, any of the DACs can be put into clamp mode and the ADC and internal reference into an inactive low-power mode to reduce current drain from the supply. The bits in the power-down register control this power-down function. Set the respective bit to 1 to activate the corresponding function.
6	PDAC-B6	R/W	0	
5	PDAC-B5	R/W	0	
4	PDAC-B4	R/W	0	
3	PDAC-A3	R/W	0	
2	PDAC-A2	R/W	0	
1	PDAC-A1	R/W	0	
0	PDAC-A0	R/W	0	

7.6.13.4 Power-Down 1 Register (address = 0xB3) [reset = 0x00]
Figure 111. Power-Down 1 Register (R/W)

7	6	5	4	3	2	1	0
PDAC-D15	PDAC-D14	PDAC-D13	PDAC-D12	PDAC-C11	PDAC-C10	PDAC-C9	PDAC-C8
R/W-0	R/W-0	R/W-0	R/W-0	R/W-0	R/W-0	R/W-0	R/W-0

Table 60. Power-Down 1 Register Field Descriptions

Bit	Field	Type	Reset	Description
7	PDAC-D15	R/W	0	After power-on or reset, all bits in the power-down register are cleared to 0, and all the components controlled by this register are either powered-down or off. The power-down register allows the host to manage the AMC7836 power dissipation. When not required, any of the DACs can be put into clamp mode and the ADC and internal reference into an inactive low-power mode to reduce current drain from the supply. The bits in the power-down register control this power-down function. Set the respective bit to 1 to activate the corresponding function.
6	PDAC-D14	R/W	0	
5	PDAC-D13	R/W	0	
4	PDAC-D12	R/W	0	
3	PDAC-C11	R/W	0	
2	PDAC-C10	R/W	0	
1	PDAC-C9	R/W	0	
0	PDAC-C8	R/W	0	

7.6.13.5 Power-Down 2 Register (address = 0xB4) [reset = 0x00]
Figure 112. Power-Down 2 Register (R/W)

7	6	5	4	3	2	1	0
Reserved						PREF	PADC
R/W-All zeros						R/W-0	R/W-0

Table 61. Power-Down 2 Register Field Descriptions

Bit	Field	Type	Reset	Description
7-2	Reserved	R/W	All zeros	Reserved for factory use.
1	PREF	R/W	0	After power-on or reset, all bits in the power-down register are cleared to 0, and all the components controlled by this register are either powered-down or off. The power-down register allows the host to manage the AMC7836 power dissipation. When not required, any of the DACs can be put into clamp mode and the ADC and internal reference into an inactive low-power mode to reduce current drain from the supply. The bits in the power-down register control this power-down function. Set the respective bit to 1 to activate the corresponding function.
0	PADC	R/W	0	

7.6.14 ADC Trigger: Address 0xC0
7.6.14.1 ADC Trigger Register (address = 0xC0) [reset = 0x00]
Figure 113. ADC Trigger Register (R/W)

7	6	5	4	3	2	1	0
Reserved							ICONV
R/W-All zeros							R/W-0

Table 62. ADC Trigger Register Field Descriptions

Bit	Field	Type	Reset	Description
7-1	Reserved	R/W	All zeros	Reserved for factory use
0	ICONV	R/W	0	Internal ADC conversion bit. Set this bit to 1 to start the ADC conversion internally. The bit is automatically cleared to 0 after the ADC conversion starts.

8 Application and Implementation

NOTE

Information in the following applications sections is not part of the TI component specification, and TI does not warrant its accuracy or completeness. TI's customers are responsible for determining suitability of components for their purposes. Customers should validate and test their design implementation to confirm system functionality.

8.1 Application Information

The AMC7836 device is a highly integrated, low-power, analog monitoring and control solution that includes a 21-channel (12-bit) ADC, 16-channel (12-bit) DACs, eight GPIO, and a local temperature sensor. Although the device can be used in many different closed-loop systems, including industrial control and test and measurement, the device is largely used as a power amplifier controller in multi-channel RF communication applications.

Power amplifiers (PAs) include transistor technologies that are extremely temperature sensitive, and require DC biasing circuits to optimize RF performance, power efficiency, and stability. The AMC7836 device provides 16 DAC channels which can be used to adjust the power amplifier bias points in response to temperature changes. The device also includes an internal local temperature sensor, and 21 ADC channels for general-purpose monitoring.

Current and temperature sensing are typically implemented in power amplifier controller applications. PA drain current sensing is implemented by measuring the differential voltage drop across a shunt resistor. Temperature variations during PA operation can be detected either through the AMC7836 internal temperature sensor or through remote temperature ICs or thermistors configured to interface with the ADC analog inputs available in the device. Figure 114 shows the block diagram for these different systems.

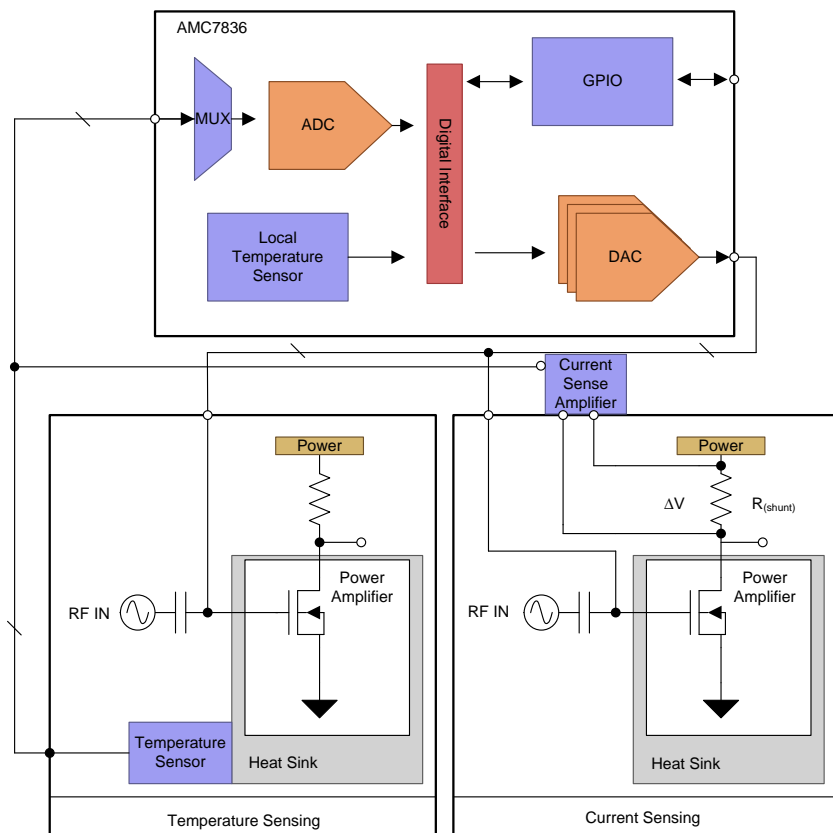

Figure 114. AMC7836 Example Control and Monitor System

Application Information (continued)

8.1.1 Temperature Sensing Applications

The AMC7836 device contains one local temperature and five unipolar analog inputs that are easily configurable to interface with remote temperature-sensor circuits. The integrated temperature sensor and analog input registers automatically update with every conversion. [Figure 115](#) shows an example of a remote temperature sensor connection.

The selected temperature sensor is the LM50 device, a high precision integrated-circuit temperature sensor that operates in the -40°C to 125°C temperature range using a single positive supply. The full-scale output of the temperature sensor ranges from 100 mV to 1.75 V for the operational temperature range. In an extremely noisy environment, additional filtering is recommended. A typical value for the bypass capacitor is $0.1\ \mu\text{F}$ from the $V+$ pin to GND. A high-quality ceramic type NP0 or X7R is recommended because of optimal performance across temperature and very low dissipation factor.

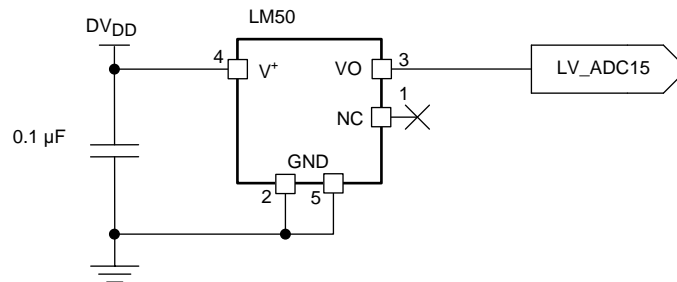

Figure 115. Temperature Sensing Application With LM50

Application Information (continued)

8.1.2 Current Sensing Applications

In applications that require current sensing of the power amplifier, an external high-side current sense amplifier can be added and configured to the unipolar ADC inputs. Figure 116 shows this design.

The LMP8480 device is a precision current sense device that amplifies the small differential voltage developed across a current-sense resistor in the presence of high input common-mode voltages. The LMP8480 device accepts input signals with a common-mode voltage range from 4 V to 76 V with a bandwidth of 270 kHz. The LMP8480 device offers different fixed gain settings. The optimal gain setting is dependent on the accuracy requirement of the application. To maintain precision over temperature, the output of the LMP8480 device should be directly connected to the AMC7836 unipolar ADC inputs. If the output range of the LMP8480 device is scaled by a voltage divider, as shown in Figure 116, an output amplifier may be required to drive the ADC unipolar input to ensure a low impedance source. If the series resistance, in this case R4, is low enough then the buffer may not be required because the LMP8480 device is capable of driving the input of the AMC7836 unipolar ADC channel.

NOTE

The external resistors will cause some small error because of temperature drift and the input bias current of the operation amplifier.

Figure 116 also shows a simple method to ensure proper power sequencing of the power amplifier by adding a series PMOS transistor to the PA drain terminal. The activation of the PMOS transistor connects the PAV_{DD} voltage supply to the drain pin of the power amplifier. The PMOS transistor is driven with a voltage divider that swings from the PAV_{DD} voltage to PAV_{DD} × (R2 / (R1 + R2)). The NMOS shown in Figure 116 is connected to a microcontroller output that controls the state of the PMOS transistor.

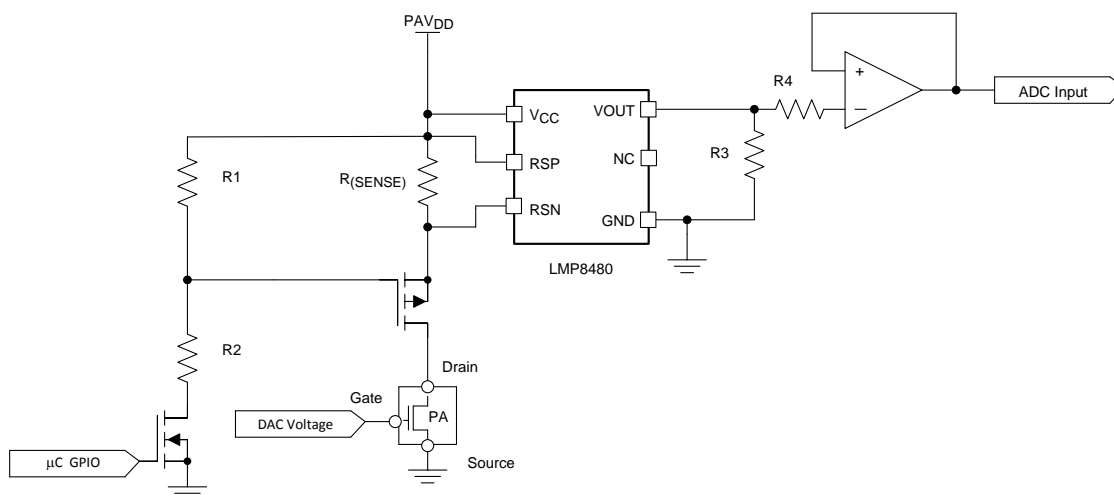

Figure 116. Current-Sense Application With PMOS ON and OFF

AMC7836

SLAS986C –NOVEMBER 2014–REVISED APRIL 2016

www.ti.com

8.2 Typical Application

Figure 117 shows an example schematic incorporating the AMC7836 device.

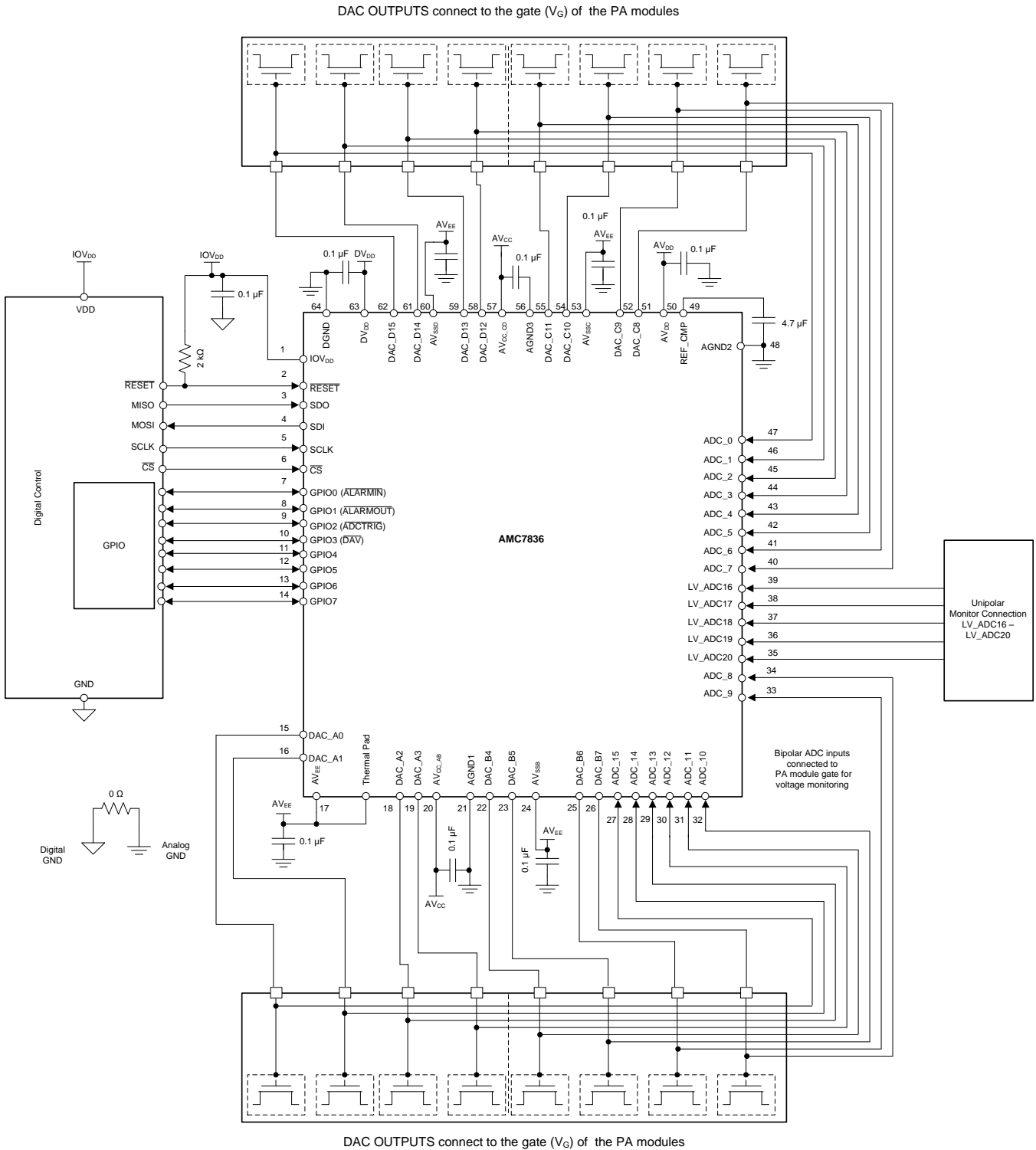

Figure 117. AMC7836 Example Schematic

Typical Application (continued)

8.2.1 Design Requirements

The AMC7836 example schematic uses the majority of the design parameters listed in [Table 63](#).

Table 63. Design Parameters

DESIGN PARAMETER	EXAMPLE VALUE
AV_{CC}	5 V
AV_{EE}	–12 V
IOV_{DD}	3.3 V
DV_{DD}	5 V
AV_{DD}	5 V
AV_{SS} banks	AV_{EE}
ADC bipolar inputs	ADC[0-15]: –12.5 to 12.5 V input range
ADC unipolar inputs	LV_ADC[16-20]: 0 to 5 V range
DAC outputs	Sixteen Monotonic 12-bit DACs Selectable ranges: 0 to 5 V, 0 to 10 V, –10 to 0 V or –5 to 0 V
Remote temperature sensing	IC temperature sensor (LM50) or thermistor

8.2.2 Detailed Design Procedure

Use the following parameters to facilitate the design process:

- AV_{CC} and AV_{EE} voltage values
- ADC input voltage range
- DAC Output voltage Ranges

8.2.2.1 ADC Input Conditioning

The AMC7836 device has an ADC with 21 analog inputs for external voltage sensing. Sixteen of these inputs are bipolar and the other five are unipolar. The bipolar inputs (ADC_0 through ADC_15) range is –12.5 to 12.5 V, and the unipolar analog inputs (LV_ADC16 through LV_ADC20) range is 0 to $2 \times V_{ref}$. The ADC operates from an internal 2.5 V reference (V_{ref} , measured at the REF_CMP pin). For additional noise filtering, a 4.7- μ F capacitor should be connected between the REF_CMP and AGND2 pins. A high-quality ceramic type NPO or X7R is recommended because of the optimal performance of the capacitor across temperature and very-low dissipation factor.

The ADC timing signals are driven from an on-chip temperature compensated 4 MHz oscillator. The on-chip oscillator is primarily responsible for the sampling frequency of the ADC. The sampling frequency of the ADC is dynamic and dependent on the acquisition and conversion time of each channel. [Table 64](#) lists the relationship between the total update time and the internal oscillator frequency.

Table 64. ADC Conversion Rate and Total Update Number of Clocks

ADC CONVERSION RATE	ADC INPUT CHANNEL	ACQUISITION CLOCKS	CONVERSION CLOCKS	t _S (ACQUISITION + CONVERSION) NUMBER OF CLOCKS
00	Bipolar	124.5	13.5	138
	Unipolar	32.5	13.5	46
	Internal Temperature Sensor	—	—	1025
01	Bipolar	124.5	13.5	138
	Unipolar	78.5	13.5	92
	Internal Temperature Sensor	—	—	1025
10	Bipolar	124.5	13.5	138
	Unipolar	124.5	13.5	138
	Internal Temperature Sensor	—	—	1025
11	Bipolar	262.5	13.5	276
	Unipolar	262.5	13.5	276
	Internal Temperature Sensor	—	—	1025

The minimum and maximum oscillator frequency specifications in conjunction with the number of clocks required for the unipolar, bipolar and temperature sensor inputs should be applied to [Equation 5](#) to calculate the total update time range.

$$T_S = \frac{(B_{CLK} \times \#B_{CH} + U_{CLK} \times \#U_{CH} + T_{CLK} \times \#T_{CH})}{f_{OSC}}$$

where

- T_S is the total update time
 - B_{CLK} is the total bipolar clocks
 - #B_{CH} is the number of active bipolar inputs
 - U_{CLK} is the total unipolar clocks
 - #U_{CH} is the number of active unipolar inputs
 - T_{CLK} is the total internal temperature-sensor clocks
 - #T_{CH} is the number of active internal temperature sensor channels; either 1 or 0
 - f_{OSC} is the internal oscillator frequency
- (5)

The following is an example of a complete calculation of the total update time range. In this example, the ADC conversion rate is set to 00 and the following ADC input channels are used:

- Bipolar channels: ADC_1 through ADC_5 (5 active bipolar channels)
- Unipolar channels: LV_ADC16 through LV_ADC18 (3 active unipolar channels)
- Internal temperature sensor (1 active temperature channel)

[Table 64](#) gives the total number of clocks required for each ADC input under the example conditions.

For the minimum specified oscillator frequency of 3.7 MHz, and with the ADC conversion rate set to 00, use [Equation 6](#) to calculate the total maximum update time for this example.

$$T_S = \frac{(138 \times 5 + 46 \times 3 + 1025 \times 1)}{3.7 \text{ MHz}} = 500.811 \mu\text{s}$$
(6)

For the maximum specified oscillator frequency of 4.3 MHz, use [Equation 7](#) to calculate the total minimum update time for this example.

$$T_S = \frac{(138 \times 5 + 46 \times 3 + 1025 \times 1)}{4.3 \text{ MHz}} = 430.93 \mu\text{s}$$
(7)

Therefore, the total update time range is 430.93 μs to 500.811 μs.

During the conversion, the input current per channel varies with the total update time which is determined by the number and type of channels (NCH) and the conversion rate setting of the CONV-RATE bit in the ADC configuration register (address 0x10).

NOTE

The source of the analog input voltage must be able to charge the input capacitance to a 12-bit settling level within the acquisition time.

8.2.2.2 DAC Output Range Selection

The AMC7836 device includes 16 DACs split into four groups, each with four DACs. All of the DACs in a given group share the same output voltage range. The output range for each DAC group is independent and is programmable to either -10 to 0 V, -5 to 0 V, 0 to 10 V or 0 to 5 V. The DAC output ranges are configured by following the configuration settings listed in Table 1.

Each DAC includes an output buffer is capable of generating rail-to rail voltages. The *Electrical Characteristics: DAC* table lists the maximum source and sink capability of this internal amplifier. The graphs in the *Application Curves* section show the relationship of both stability and settling time with different capacitive loading structures.

8.2.3 Application Curves

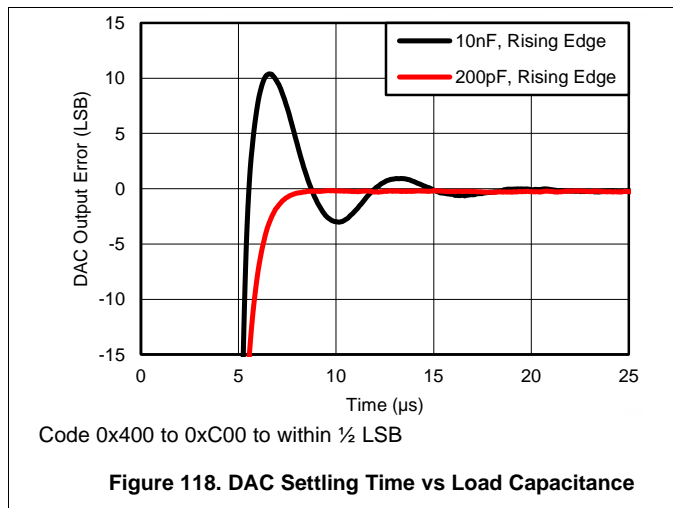

Figure 118. DAC Settling Time vs Load Capacitance

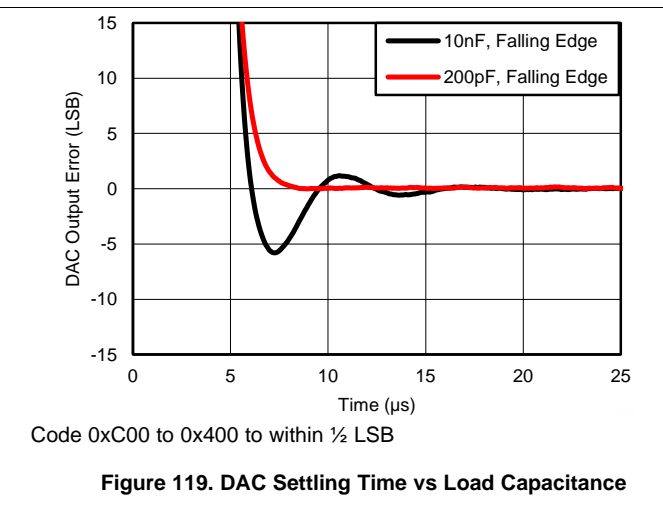

Figure 119. DAC Settling Time vs Load Capacitance

9 Power Supply Recommendations

The preferred (not required) pin order for applying power is IOV_{DD}, DV_{DD} and AV_{DD}, AV_{CC} and lastly AV_{EE}, AV_{SSB}, AV_{SSC}, and AV_{SSD}. When power sequencing, ensure that all digital pins are not powered or in an active state while the IOV_{DD} pin ramps. Proper sequencing of the digital pins can be accomplished by attaching 10-kΩ pullup resistors to the IOV_{DD} pin, or pulldown resistors to the DGND pin. See the supply voltage ranges in the *Recommended Operating Conditions* table.

In applications where a negative voltage is applied to AV_{EE}, AV_{SSB}, AV_{SSC}, and AV_{SSD} first, the user may notice some small negative voltages at other supply pins, such as the AV_{DD}, DV_{DD}, and AV_{CC} pins. The negative voltages at the supply pins may exceed the values listed in the *Absolute Maximum Ratings* table, but because these voltages are created from intrinsic circuitry, the voltage levels are safe for operation. Although these negative voltages are observed on the pins, the user must still adhere to the guidelines specified in the *Absolute Maximum Ratings* table and verify that the inputs are driven within the range specified in the table. The user should also ensure that current is only applied when operating with voltages between the ranges listed in the *Absolute Maximum Ratings* table.

9.1 Device Reset Options

9.1.1 Power-on-Reset (POR)

The AMC7836 device includes a power-on reset (POR) function. After all supplies have been established, a POR event is issued. The POR causes all registers to initialize to the default values, and communication with the device is valid only after a 250 μ s power-on reset delay.

The default operation is power-down mode (register 0x02) in which the device is non-operational except for the communication interface as determined by the power-down registers. Before enabling normal operation, a hardware reset should be issued.

A power failure on DV_{DD} , AV_{DD} , AV_{CC} or IOV_{DD} has the potential to initiate a power-on-reset event. As long as DV_{DD} , AV_{DD} , AV_{CC} , and IOV_{DD} remain above the minimum recommended operating conditions a power failure event will not occur. When any of these supplies drops below the minimum recommended operating condition the device may or may not imitate a POR. In this case, issuing a hardware reset or proper POR is recommended to resume proper operation. To ensure a proper POR event, the DV_{DD} supply must fall below 750 mV. If the DV_{DD} supply falls below 2.7 V a hardware reset or proper POR must be issued.

9.1.2 Hardware Reset

A device hardware reset event is initiated by a minimum 20-ns logic low on the \overline{RESET} pin. A hardware reset causes all registers to initialize to the default values and communication with the device is valid only after a 250- μ s reset delay.

9.1.2.1 Software Reset

A software reset event is initiated by setting the SOFT-RESET bit in the interface configuration 0 register (0x00). A software reset causes all registers, except 0x00 and 0x01, to initialize to the default values and communication with the device is valid only after a 100-ns delay.

10 Layout

10.1 Layout Guidelines

- All power supply pins should be bypassed to ground with a low-ESR ceramic bypass capacitor. The typical recommended bypass capacitor has a value of 10- μ F and is ceramic with a X7R or NP0 dielectric.
- To minimize interaction between the analog and digital return currents, the digital and analog sections should have separate ground planes that eventually connect at some point.
- To reduce noise on the internal reference, a 4.7- μ F capacitor is recommended between the REF_CMP pin and ground.
- A high-quality ceramic type NP0 or X7R capacitor is recommended because of the optimal performance across temperature very-low dissipation factor of the capacitor.
- The digital and analog sections should have proper placement with respect to the digital pins and analog pins of the AMC7836 device (see [Figure 121](#)). The separation of analog and digital blocks allows for better design and practice as it ensures less coupling into neighboring blocks and minimizes the interaction between analog and digital return currents.

10.2 Layout Example

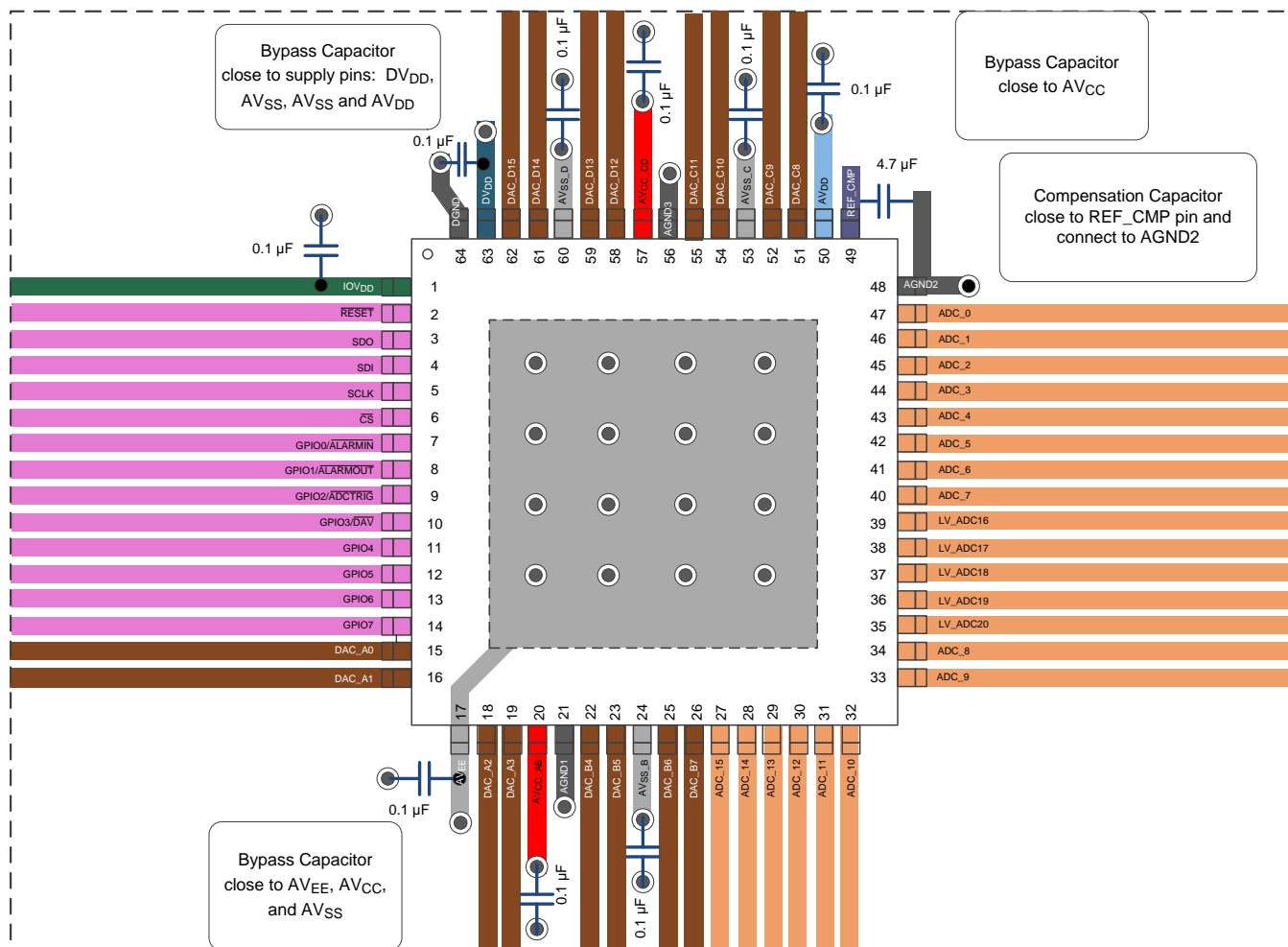

Figure 120. AMC7836 Example Board Layout

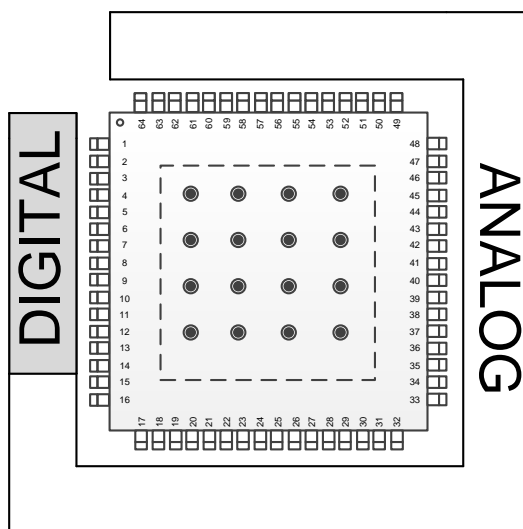

Figure 121. AMC7836 Example Board Layout — Component Placement

11 Device and Documentation Support

11.1 Documentation Support

11.1.1 Related Documentation

For related documentation see the following:

- *LMP8480 / LMP8481 Precision 76V High-Side Current Sense Amplifiers with Voltage Output*, [SNVS829](#)
- *LM50/LM50-Q1 SOT-23 Single-Supply Centigrade Temperature Sensor*, [SNIS118](#)

11.2 Community Resources

The following links connect to TI community resources. Linked contents are provided "AS IS" by the respective contributors. They do not constitute TI specifications and do not necessarily reflect TI's views; see TI's [Terms of Use](#).

TI E2E™ Online Community *TI's Engineer-to-Engineer (E2E) Community*. Created to foster collaboration among engineers. At [e2e.ti.com](#), you can ask questions, share knowledge, explore ideas and help solve problems with fellow engineers.

Design Support *TI's Design Support* Quickly find helpful E2E forums along with design support tools and contact information for technical support.

11.3 Trademarks

PowerPAD, E2E are trademarks of Texas Instruments. All other trademarks are the property of their respective owners.

11.4 Electrostatic Discharge Caution



These devices have limited built-in ESD protection. The leads should be shorted together or the device placed in conductive foam during storage or handling to prevent electrostatic damage to the MOS gates.

11.5 Glossary

[SLYZ022](#) — *TI Glossary*.

This glossary lists and explains terms, acronyms, and definitions.

12 Mechanical, Packaging, and Orderable Information

The following pages include mechanical, packaging, and orderable information. This information is the most current data available for the designated devices. This data is subject to change without notice and revision of this document. For browser-based versions of this data sheet, refer to the left-hand navigation.

PACKAGING INFORMATION

Orderable Device	Status (1)	Package Type	Package Drawing	Pins	Package Qty	Eco Plan (2)	Lead/Ball Finish (6)	MSL Peak Temp (3)	Op Temp (°C)	Device Marking (4/5)	Samples
AMC7836IPAP	ACTIVE	HTQFP	PAP	64	160	Green (RoHS & no Sb/Br)	CU NIPDAU	Level-3-260C-168 HR	-40 to 125	AMC7836	Samples
AMC7836IPAPR	ACTIVE	HTQFP	PAP	64	1000	Green (RoHS & no Sb/Br)	CU NIPDAU	Level-3-260C-168 HR	-40 to 125	AMC7836	Samples

(1) The marketing status values are defined as follows:

ACTIVE: Product device recommended for new designs.

LIFEBUY: TI has announced that the device will be discontinued, and a lifetime-buy period is in effect.

NRND: Not recommended for new designs. Device is in production to support existing customers, but TI does not recommend using this part in a new design.

PREVIEW: Device has been announced but is not in production. Samples may or may not be available.

OBsolete: TI has discontinued the production of the device.

(2) Eco Plan - The planned eco-friendly classification: Pb-Free (RoHS), Pb-Free (RoHS Exempt), or Green (RoHS & no Sb/Br) - please check <http://www.ti.com/productcontent> for the latest availability information and additional product content details.

TBD: The Pb-Free/Green conversion plan has not been defined.

Pb-Free (RoHS): TI's terms "Lead-Free" or "Pb-Free" mean semiconductor products that are compatible with the current RoHS requirements for all 6 substances, including the requirement that lead not exceed 0.1% by weight in homogeneous materials. Where designed to be soldered at high temperatures, TI Pb-Free products are suitable for use in specified lead-free processes.

Pb-Free (RoHS Exempt): This component has a RoHS exemption for either 1) lead-based flip-chip solder bumps used between the die and package, or 2) lead-based die adhesive used between the die and leadframe. The component is otherwise considered Pb-Free (RoHS compatible) as defined above.

Green (RoHS & no Sb/Br): TI defines "Green" to mean Pb-Free (RoHS compatible), and free of Bromine (Br) and Antimony (Sb) based flame retardants (Br or Sb do not exceed 0.1% by weight in homogeneous material)

(3) MSL, Peak Temp. - The Moisture Sensitivity Level rating according to the JEDEC industry standard classifications, and peak solder temperature.

(4) There may be additional marking, which relates to the logo, the lot trace code information, or the environmental category on the device.

(5) Multiple Device Markings will be inside parentheses. Only one Device Marking contained in parentheses and separated by a "~" will appear on a device. If a line is indented then it is a continuation of the previous line and the two combined represent the entire Device Marking for that device.

(6) Lead/Ball Finish - Orderable Devices may have multiple material finish options. Finish options are separated by a vertical ruled line. Lead/Ball Finish values may wrap to two lines if the finish value exceeds the maximum column width.

Important Information and Disclaimer: The information provided on this page represents TI's knowledge and belief as of the date that it is provided. TI bases its knowledge and belief on information provided by third parties, and makes no representation or warranty as to the accuracy of such information. Efforts are underway to better integrate information from third parties. TI has taken and continues to take reasonable steps to provide representative and accurate information but may not have conducted destructive testing or chemical analysis on incoming materials and chemicals. TI and TI suppliers consider certain information to be proprietary, and thus CAS numbers and other limited information may not be available for release.

In no event shall TI's liability arising out of such information exceed the total purchase price of the TI part(s) at issue in this document sold by TI to Customer on an annual basis.

TAPE AND REEL INFORMATION



QUADRANT ASSIGNMENTS FOR PIN 1 ORIENTATION IN TAPE



*All dimensions are nominal

Device	Package Type	Package Drawing	Pins	SPQ	Reel Diameter (mm)	Reel Width W1 (mm)	A0 (mm)	B0 (mm)	K0 (mm)	P1 (mm)	W (mm)	Pin1 Quadrant
AMC7836IPAPR	HTQFP	PAP	64	1000	330.0	24.4	13.0	13.0	1.5	16.0	24.0	Q2

TAPE AND REEL BOX DIMENSIONS



*All dimensions are nominal

Device	Package Type	Package Drawing	Pins	SPQ	Length (mm)	Width (mm)	Height (mm)
AMC7836IPAPR	HTQFP	PAP	64	1000	367.0	367.0	55.0

PAP (S-PQFP-G64)

PowerPAD™ PLASTIC QUAD FLATPACK



- NOTES:
- A. All linear dimensions are in millimeters.
 - B. This drawing is subject to change without notice.
 - C. Body dimensions do not include mold flash or protrusion
 - D. This package is designed to be soldered to a thermal pad on the board. Refer to Technical Brief, PowerPad Thermally Enhanced Package, Texas Instruments Literature No. SLMA002 for information regarding recommended board layout. This document is available at www.ti.com <<http://www.ti.com>>.
 - E. Falls within JEDEC MS-026

PowerPAD is a trademark of Texas Instruments.

THERMAL PAD MECHANICAL DATA

PAP (S-PQFP-G64)

PowerPAD™ PLASTIC QUAD FLATPACK

THERMAL INFORMATION

This PowerPAD™ package incorporates an exposed thermal pad that is designed to be attached to a printed circuit board (PCB). The thermal pad must be soldered directly to the PCB. After soldering, the PCB can be used as a heatsink. In addition, through the use of thermal vias, the thermal pad can be attached directly to the appropriate copper plane shown in the electrical schematic for the device, or alternatively, can be attached to a special heatsink structure designed into the PCB. This design optimizes the heat transfer from the integrated circuit (IC).

For additional information on the PowerPAD package and how to take advantage of its heat dissipating abilities, refer to Technical Brief, PowerPAD Thermally Enhanced Package, Texas Instruments Literature No. SLMA002 and Application Brief, PowerPAD Made Easy, Texas Instruments Literature No. SLMA004. Both documents are available at www.ti.com.

The exposed thermal pad dimensions for this package are shown in the following illustration.

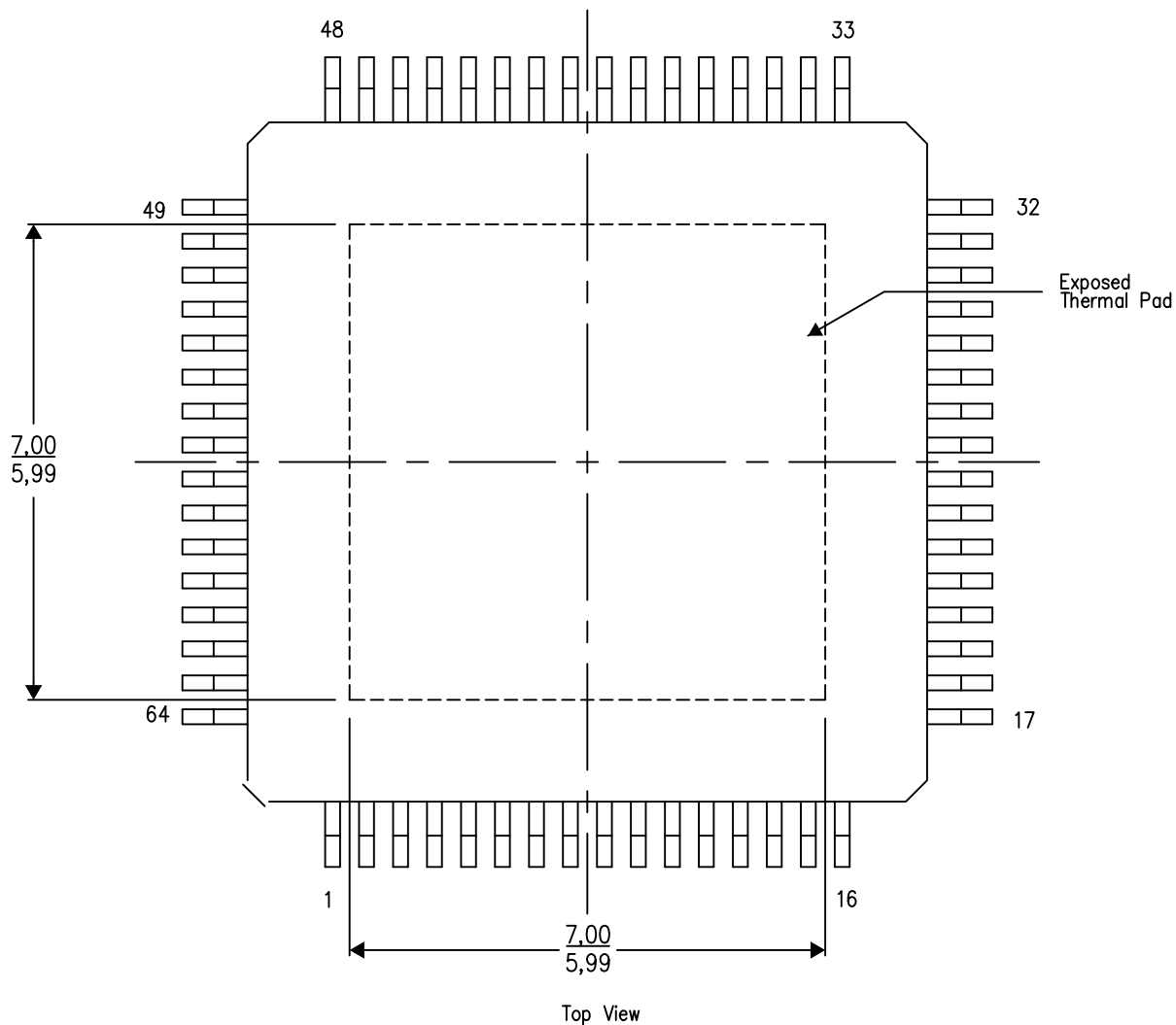

4206326-5/P 05/14

NOTES: A. All linear dimensions are in millimeters

PowerPAD is a trademark of Texas Instruments

LAND PATTERN DATA

PAP (S-PQFP-G64)

PowerPAD™ PLASTIC QUAD FLATPACK

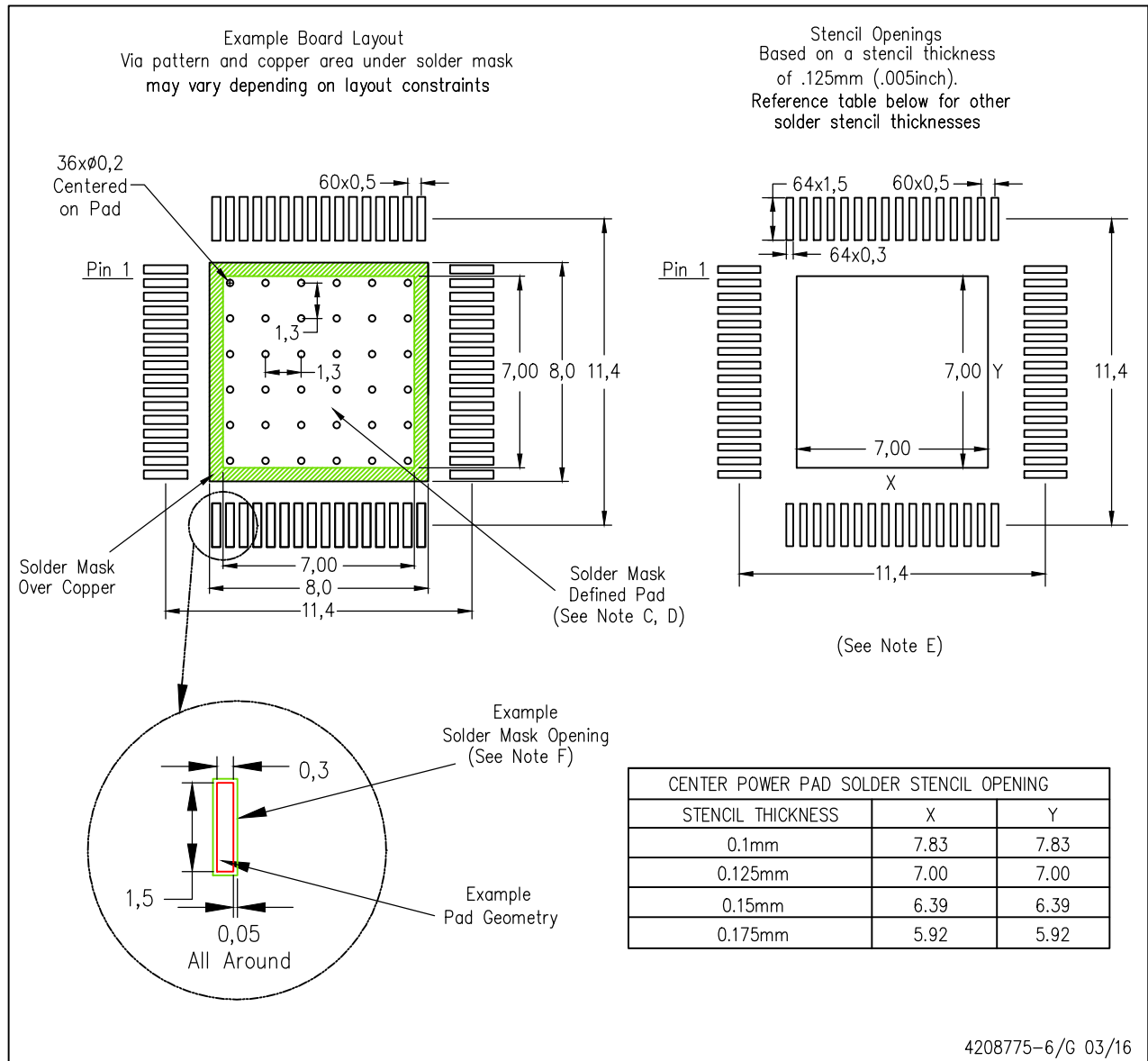

4208775-6/G 03/16

- NOTES:
- All linear dimensions are in millimeters.
 - This drawing is subject to change without notice.
 - Customers should place a note on the circuit board fabrication drawing not to alter the center solder mask defined pad.
 - This package is designed to be soldered to a thermal pad on the board. Refer to Technical Brief, PowerPad Thermally Enhanced Package, Texas Instruments Literature No. SLMA002, SLMA004, and also the Product Data Sheets for specific thermal information, via requirements, and recommended board layout. These documents are available at www.ti.com <<http://www.ti.com>>. Publication IPC-7351 is recommended for alternate designs.
 - Laser cutting apertures with trapezoidal walls and also rounding corners will offer better paste release. Customers should contact their board assembly site for stencil design recommendations. Example stencil design based on a 50% volumetric metal load solder paste. Refer to IPC-7525 for other stencil recommendations.
 - Customers should contact their board fabrication site for solder mask tolerances between and around signal pads.
- PowerPAD is a trademark of Texas Instruments**

IMPORTANT NOTICE

Texas Instruments Incorporated and its subsidiaries (TI) reserve the right to make corrections, enhancements, improvements and other changes to its semiconductor products and services per JESD46, latest issue, and to discontinue any product or service per JESD48, latest issue. Buyers should obtain the latest relevant information before placing orders and should verify that such information is current and complete. All semiconductor products (also referred to herein as "components") are sold subject to TI's terms and conditions of sale supplied at the time of order acknowledgment.

TI warrants performance of its components to the specifications applicable at the time of sale, in accordance with the warranty in TI's terms and conditions of sale of semiconductor products. Testing and other quality control techniques are used to the extent TI deems necessary to support this warranty. Except where mandated by applicable law, testing of all parameters of each component is not necessarily performed.

TI assumes no liability for applications assistance or the design of Buyers' products. Buyers are responsible for their products and applications using TI components. To minimize the risks associated with Buyers' products and applications, Buyers should provide adequate design and operating safeguards.

TI does not warrant or represent that any license, either express or implied, is granted under any patent right, copyright, mask work right, or other intellectual property right relating to any combination, machine, or process in which TI components or services are used. Information published by TI regarding third-party products or services does not constitute a license to use such products or services or a warranty or endorsement thereof. Use of such information may require a license from a third party under the patents or other intellectual property of the third party, or a license from TI under the patents or other intellectual property of TI.

Reproduction of significant portions of TI information in TI data books or data sheets is permissible only if reproduction is without alteration and is accompanied by all associated warranties, conditions, limitations, and notices. TI is not responsible or liable for such altered documentation. Information of third parties may be subject to additional restrictions.

Resale of TI components or services with statements different from or beyond the parameters stated by TI for that component or service voids all express and any implied warranties for the associated TI component or service and is an unfair and deceptive business practice. TI is not responsible or liable for any such statements.

Buyer acknowledges and agrees that it is solely responsible for compliance with all legal, regulatory and safety-related requirements concerning its products, and any use of TI components in its applications, notwithstanding any applications-related information or support that may be provided by TI. Buyer represents and agrees that it has all the necessary expertise to create and implement safeguards which anticipate dangerous consequences of failures, monitor failures and their consequences, lessen the likelihood of failures that might cause harm and take appropriate remedial actions. Buyer will fully indemnify TI and its representatives against any damages arising out of the use of any TI components in safety-critical applications.

In some cases, TI components may be promoted specifically to facilitate safety-related applications. With such components, TI's goal is to help enable customers to design and create their own end-product solutions that meet applicable functional safety standards and requirements. Nonetheless, such components are subject to these terms.

No TI components are authorized for use in FDA Class III (or similar life-critical medical equipment) unless authorized officers of the parties have executed a special agreement specifically governing such use.

Only those TI components which TI has specifically designated as military grade or "enhanced plastic" are designed and intended for use in military/aerospace applications or environments. Buyer acknowledges and agrees that any military or aerospace use of TI components which have **not** been so designated is solely at the Buyer's risk, and that Buyer is solely responsible for compliance with all legal and regulatory requirements in connection with such use.

TI has specifically designated certain components as meeting ISO/TS16949 requirements, mainly for automotive use. In any case of use of non-designated products, TI will not be responsible for any failure to meet ISO/TS16949.

Products

Audio	www.ti.com/audio
Amplifiers	amplifier.ti.com
Data Converters	dataconverter.ti.com
DLP® Products	www.dlp.com
DSP	dsp.ti.com
Clocks and Timers	www.ti.com/clocks
Interface	interface.ti.com
Logic	logic.ti.com
Power Mgmt	power.ti.com
Microcontrollers	microcontroller.ti.com
RFID	www.ti-rfid.com
OMAP Applications Processors	www.ti.com/omap
Wireless Connectivity	www.ti.com/wirelessconnectivity

Applications

Automotive and Transportation	www.ti.com/automotive
Communications and Telecom	www.ti.com/communications
Computers and Peripherals	www.ti.com/computers
Consumer Electronics	www.ti.com/consumer-apps
Energy and Lighting	www.ti.com/energy
Industrial	www.ti.com/industrial
Medical	www.ti.com/medical
Security	www.ti.com/security
Space, Avionics and Defense	www.ti.com/space-avionics-defense
Video and Imaging	www.ti.com/video

TI E2E Community

e2e.ti.com