

FEATURES
2-input, 2-output crosspoint HDMI transceiver
HDMI support

3 GHz video support (up to 4k × 2k)

Audio return channel (ARC)

3D TV support

Content type bits

CEC 1.4-compatible

Extended colorimetry

Character- and icon-based on-screen display (OSD)

3D OSD overlay on all mandatory 3D formats

Support for OSD overlay on 3 GHz video formats

High-bandwidth Digital Content Protection (HDCP 1.4)
HDCP repeater support: up to 127 KSVs supported
300 MHz maximum TMDS clock frequency (up to 4k × 2k)
48-/36-/30-bit Deep Color input modes supported
Ultralow jitter digital PLL (100% deskew)
2 independent HDMI receivers

3 GHz support on all inputs

Adaptive equalizer for cable lengths up to 30 meters

Flexible internal EDID RAM supports dual EDIDs

Replication of either dual EDID on any input port

5 V detect inputs

Hot Plug assert control outputs

2 independent HDMI transmitters

3 GHz support on all outputs

EDID data extraction

Hot Plug detect (HPD) inputs

Audio return channel (ARC) receiver per transmitter

3 GHz color space converter (CSC) per transmitter

Audio

HDMI-compatible audio interface

2 independent 8-channel audio extraction ports

2 independent 8-channel audio insertion ports

S/PDIF (IEC 60958-compatible) digital audio input/output

Super Audio CD® (SACD) with DSD input/output interface

High bit rate (HBR) audio

Dolby® TrueHD

DTS-HD Master Audio™

Full audio input and output support

General

Interrupt controller

Standard identification (STDI) circuit

Software libraries, driver, and application available

APPLICATIONS
AVR

Soundbar with HDMI repeater support

Matrix switch

Other repeater applications

FUNCTIONAL BLOCK DIAGRAM

Figure 1.

11832-001

Rev. 0

Document Feedback

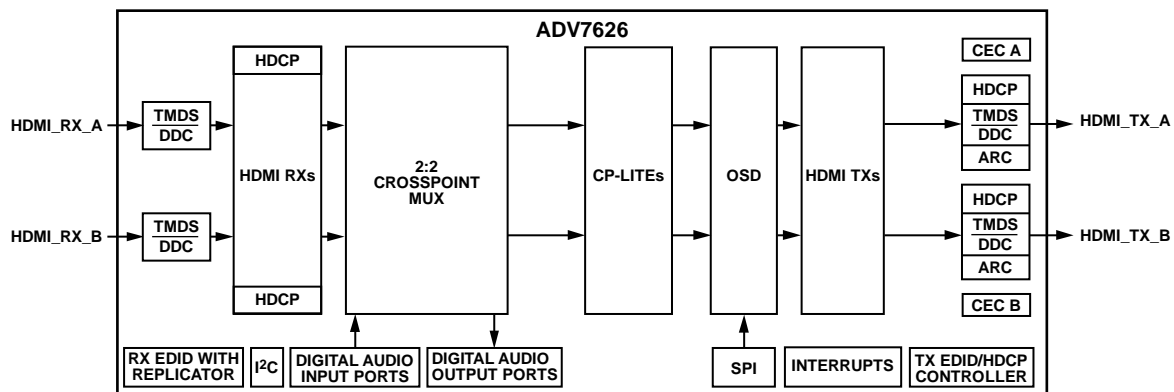
Information furnished by Analog Devices is believed to be accurate and reliable. However, no responsibility is assumed by Analog Devices for its use, nor for any infringements of patents or other rights of third parties that may result from its use. Specifications subject to change without notice. No license is granted by implication or otherwise under any patent or patent rights of Analog Devices. Trademarks and registered trademarks are the property of their respective owners.

One Technology Way, P.O. Box 9106, Norwood, MA 02062-9106, U.S.A.

Tel: 781.329.4700

©2013 Analog Devices, Inc. All rights reserved.

Technical Support
www.analog.com

TABLE OF CONTENTS

Features	1	Power Supply Recommendations.....	21
Applications.....	1	Power-Up Sequence	21
Functional Block Diagram	1	Power-Down Sequence.....	21
Revision History	2	Theory of Operation	22
General Description	3	HDMI Receiver.....	22
Detailed Functional Block Diagram	4	HDCP Repeater Functionality	22
Specifications.....	5	Digital Audio Ports	22
Digital, HDMI, and AC Specifications	5	On-Screen Display	22
Data and I ² C Timing Characteristics.....	6	HDMI Transmitters	22
Power Specifications	12	I ² C Interface	22
Absolute Maximum Ratings.....	14	Other Features	22
Package Thermal Performance.....	14	Outline Dimensions	23
ESD Caution.....	14	Ordering Guide	23
Pin Configuration and Function Descriptions.....	15		

REVISION HISTORY

12/13—Revision 0: Initial Version

GENERAL DESCRIPTION

The [ADV7626](#) is a high performance, High-Definition Multimedia Interface (HDMI®) transceiver with crosspoint and splitter capabilities. The [ADV7626](#) supports 3 GHz video and features two independent HDMI receivers, two independent HDMI transmitters, two audio output ports, and two audio input ports. The [ADV7626](#) supports all HDCP repeater functions through fully tested Analog Devices, Inc., repeater software libraries and drivers.

The HDMI receivers and transmitters in the [ADV7626](#) support the reception and transmission of 3 GHz video formats up to 4k × 2k at 24 Hz/25 Hz/30 Hz, in addition to all mandatory HDMI 3D TV formats. The receivers and transmitters also provide support for THX® Media Director™.

Each HDMI receiver features an integrated equalizer that ensures robust operation of the interface with cable lengths up to 30 meters. The HDMI receivers share a 768-byte volatile extended display identification data (EDID) memory, which can facilitate one or two EDIDs, one for each receiver. Each HDMI port features dedicated 5 V detect and Hot Plug™ assert pins.

Each HDMI transmitter supports audio return channel (ARC) and features an integrated HDMI CEC controller that supports capability discovery and control (CDC).

The [ADV7626](#) offers two dedicated audio output ports and two dedicated audio input ports. Each audio port supports the extraction and insertion of up to eight channels of audio data out of or into the HDMI streams. HDMI audio formats, including I²S, S/PDIF, direct stream digital (DSD), and high bit rate (HBR) audio are supported.

The [ADV7626](#) has an integrated on-screen display (OSD) generator that enables the creation and control of high quality character- and icon-based system status and control displays. The OSD can be overlaid on 3 GHz video formats and 3D video. Customers who are interested in using OSD are provided with Blimp, the Analog Devices OSD development tool.

The [ADV7626](#) is provided in a space-saving, 260-ball, 15 mm × 15 mm CSP_BGA surface-mount, RoHS-compliant package and is specified over the 0°C to 70°C temperature range.

DETAILED FUNCTIONAL BLOCK DIAGRAM

11832-002

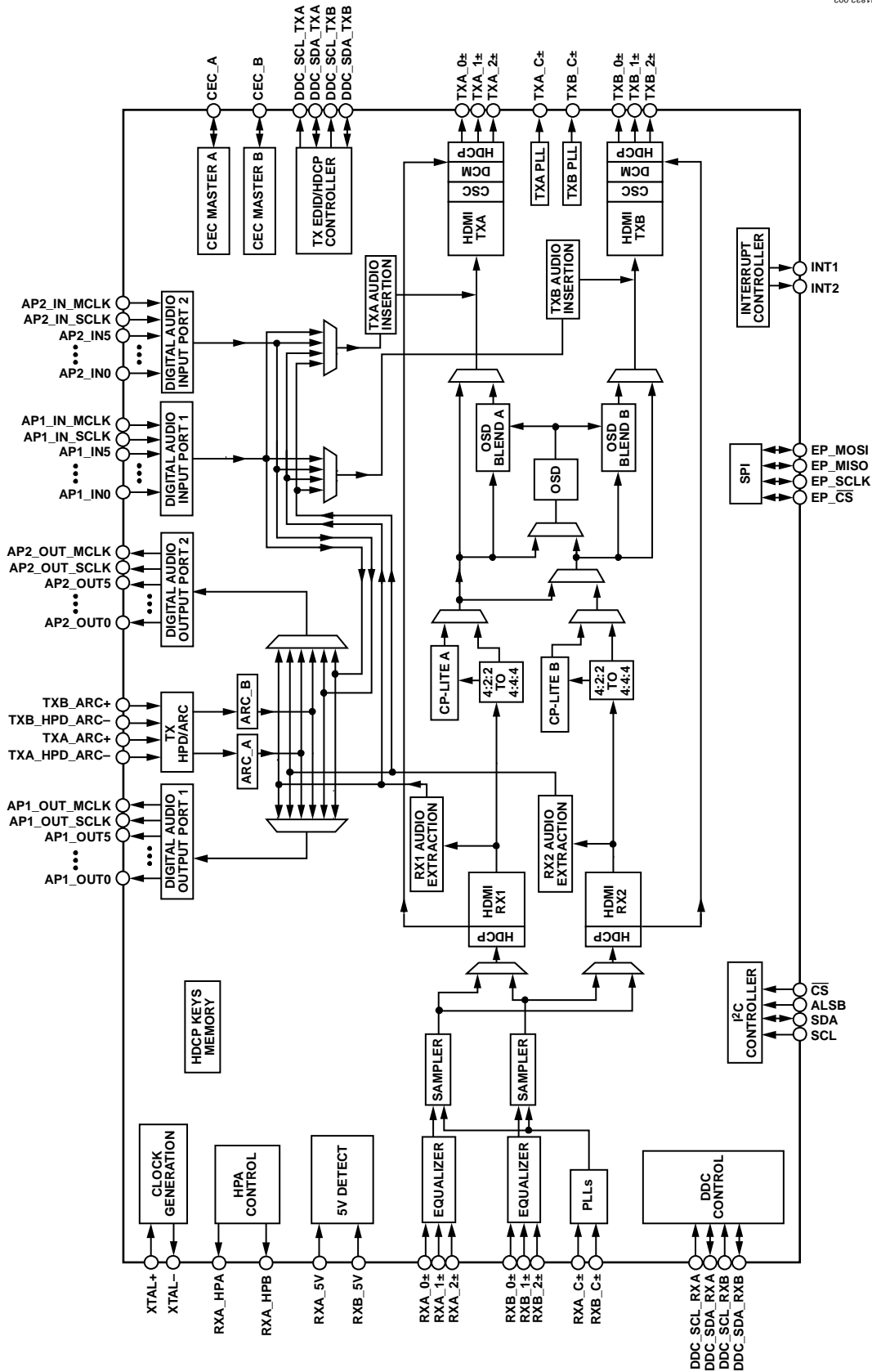

Figure 2. Detailed Functional Block Diagram

SPECIFICATIONS

AVDD_TXA = 1.8 V ± 5%, AVDD_TXB = 1.8 V ± 5%, CVDD = 1.8 V ± 5%, DVDD = 1.8 V ± 5%, DVDDIO = 3.3 V ± 5%, PVDD = 1.8 V ± 5%, PVDD_TXA = 1.8 V ± 5%, PVDD_TXB = 1.8 V ± 5%, TVDD = 3.3 V ± 5%, T_{MIN} to T_{MAX} = 0°C to 70°C.

DIGITAL, HDMI, AND AC SPECIFICATIONS

Table 1.

Parameter	Test Conditions/Comments	Min	Typ	Max	Unit
DIGITAL INPUTS					
Input High Voltage (V _{IH})		2			V
Input Low Voltage (V _{IL})				0.8	V
Input Leakage Current (I _{IN})		-60		+60	μA
Input Capacitance (C _{IN})				20	pF
DIGITAL INPUTS (5 V TOLERANT) ¹					
Input High Voltage (V _{IH})		2.85			V
Input Low Voltage (V _{IL})				0.8	V
Input Leakage Current (I _{IN})	RXA_5V and RXB_5V inputs	-450		+450	μA
	All other 5 V tolerant digital inputs	-60		+60	μA
DIGITAL OUTPUTS					
Output High Voltage (V _{OH})		2.4			V
Output Low Voltage (V _{OL})				0.4	V
High Impedance Leakage Current (I _{LEAK})			10		μA
Output Capacitance (C _{OUT})				20	pF
DIGITAL OUTPUTS (5 V TOLERANT) ²					
Output High Voltage (V _{OH})		4.85			V
Output Low Voltage (V _{OL})				0.4	V
AC SPECIFICATIONS					
TMDS Input Clock Range		25		300	MHz
TMDS Output Clock Frequency		25		300	MHz

¹ The following pins are 5 V tolerant inputs: DDC_SCL_RXA, DDC_SDA_RXA, DDC_SCL_RXB, DDC_SDA_RXB, RXA_5V, RXB_5V, CEC_A, DDC_SCL_TXA, DDC_SDA_TXA, TXA_HPD_ARC-, TXA_ARC+, CEC_B, DDC_SCL_TXB, DDC_SDA_TXB, TXB_HPD_ARC-, and TXB_ARC+.

² The following pins are 5 V tolerant outputs: RXA_HPA and RXB_HPA.

DATA AND I²C TIMING CHARACTERISTICS

Table 2.

Parameter	Symbol	Test Conditions/Comments	Min	Typ	Max	Unit
VIDEO SYSTEM CLOCK AND XTAL						
Crystal Nominal Frequency				27.0		MHz
Crystal Frequency Stability					±50	ppm
External Clock Source		External crystal must operate at 1.8 V				
Input High Voltage	V _{IH}	XTAL driven with external clock source	1.2			V
Input Low Voltage	V _{IL}	XTAL driven with external clock source			0.4	V
Serial Port EP_SCLK Frequency					27	MHz
Audio SCLK Frequency					49.152	MHz
Audio MCLK Frequency					98.304	MHz
Audio DSD Clock Frequency					5.6448	MHz
RESET FEATURE						
Reset Pulse Width			5			ms
I ² C PORTS (FAST MODE)						
xCL Frequency ¹					400	kHz
xCL Minimum Pulse Width High ¹	t ₁		600			ns
xCL Minimum Pulse Width Low ¹	t ₂		1.3			µs
Start Condition Hold Time	t ₃		600			ns
Start Condition Setup Time	t ₄		600			ns
xDA Setup Time ²	t ₅		100			ns
xCL and xDA Rise Time ^{1,2}	t ₆				300	ns
xCL and xDA Fall Time ^{1,2}	t ₇				300	ns
Setup Time (Stop Condition)	t ₈		0.6			µs
SERIAL PORT, MASTER MODE ^{3,4}		SPI Mode 0				
EP_ $\overline{\text{CS}}$ Falling Edge to EP_SCLK Rising/Falling Edge	t ₉ , t ₁₀		1 × EP_SCLK periods		1.5 × EP_SCLK periods	ns
EP_SCLK Rising/Falling Edge to EP_ $\overline{\text{CS}}$ Rising Edge	t ₁₁ , t ₁₂		1 × EP_SCLK periods		1.5 × EP_SCLK periods	ns
EP_ $\overline{\text{CS}}$ Pulse Width ⁵	t ₁₃		1000			ns
EP_SCLK High Time	t ₁₄		40		60	% duty cycle
EP_SCLK Low Time			40		60	% duty cycle
EP_MOSI Start of Data Invalid to EP_SCLK Falling Edge	t ₁₅				0	ns
EP_ $\overline{\text{CS}}$ Start of Data Invalid to EP_SCLK Falling Edge	t ₁₅				0	ns
EP_SCLK Falling Edge to EP_MOSI End of Data Invalid	t ₁₆				2.15	ns
EP_SCLK Falling Edge to EP_ $\overline{\text{CS}}$ End of Data Invalid	t ₁₆				2.15	ns
EP_MISO Setup Time	t ₁₇	Valid regardless of the EP_SCLK active edge used	7.5			ns
EP_MISO Hold Time	t ₁₈	Valid regardless of the EP_SCLK active edge used	0			ns
SERIAL PORT, SLAVE MODE ^{3,4}		SPI Mode 0				
EP_ $\overline{\text{CS}}$ Falling Edge to EP_SCLK Rising Edge	t ₂₀		10			ns
Final EP_SCLK Rising Edge to EP_ $\overline{\text{CS}}$ Rising Edge	t ₂₂		10			ns
EP_ $\overline{\text{CS}}$ Pulse Width ⁵	t ₂₃			20 × EP_SCLK periods		ns

Parameter	Symbol	Test Conditions/Comments	Min	Typ	Max	Unit
EP_SCLK High Time	t ₂₄		45		55	% duty cycle
EP_SCLK Low Time			45		55	% duty cycle
EP_MOSI Setup Time	t ₂₅		0.5			ns
EP_MOSI Hold Time	t ₂₆		1.4			ns
EP_SCLK Falling Edge to EP_MISO Start of Data Invalid	t ₂₇		5.5			ns
EP_SCLK Falling Edge to EP_MISO End of Data Invalid	t ₂₈				9	ns
AUDIO INPUT PORTS, I ² S INPUT						
APx_IN_SCLK High Time	t ₃₇		45		55	% duty cycle
APx_IN_SCLK Low Time			45		55	% duty cycle
APx_IN Data Setup Time	t ₃₈		2.3			ns
APx_IN Data Hold Time	t ₃₉		1.6			ns
AUDIO INPUT PORTS, DSD INPUT						
APx_IN_SCLK High Time	t ₄₀		45		55	% duty cycle
APx_IN_SCLK Low Time			45		55	% duty cycle
APx_IN DSD Data Setup Time	t ₄₁		2.3			ns
APx_IN DSD Data Hold Time	t ₄₂		1.6			ns
AUDIO OUTPUT PORTS, I ² S OUTPUT						
APx_OUT_SCLK High Time	t ₄₆		45		55	% duty cycle
APx_OUT_SCLK Low Time			45		55	% duty cycle
APx_OUT LRCLK Transition Time	t ₄₇	Start of invalid LRCLK to falling APx_OUT_SCLK edge			10	ns
APx_OUT LRCLK Transition Time	t ₄₈	Falling APx_OUT_SCLK edge to end of invalid LRCLK			10	ns
APx_OUT Data Transition Time	t ₄₉	Start of invalid data to falling APx_OUT_SCLK edge			10	ns
APx_OUT Data Transition Time	t ₅₀	Falling APx_OUT_SCLK edge to end of invalid data			10	ns
AUDIO OUTPUT PORTS, DSD OUTPUT						
APx_OUT_SCLK High Time	t ₅₁		45		55	% duty cycle
APx_OUT_SCLK Low Time			45		55	% duty cycle
APx_OUT DSD Data Transition Time	t ₅₂	Start of invalid data to falling APx_OUT_SCLK edge			10	ns
APx_OUT DSD Data Transition Time	t ₅₃	Falling APx_OUT_SCLK edge to end of invalid data			10	ns

¹ xCL refers to SCL, DDC_SCL_RXA, and DDC_SCL_RXB.

² xDA refers to SDA, DDC_SDA_RXA, and DDC_SDA_RXB.

³ SPI Mode 0 only.

⁴ All serial port measurements are for CPHA = 0, CPOL = 0 (clock is low in idle state; negative edge of clock is used to transmit data and positive edge is used to sample data).

⁵ Measurements guaranteed by design only.

Timing Diagrams

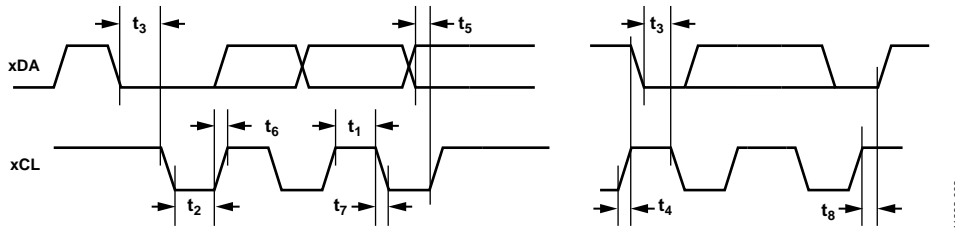

Figure 3. I²C Timing

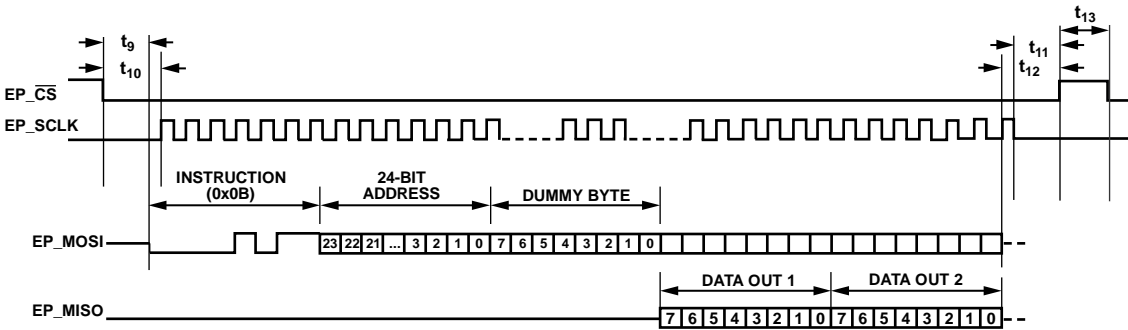

Figure 4. Detailed SPI Master Timing Diagram (SPI Mode 0, CPOL = CPHA = 0)

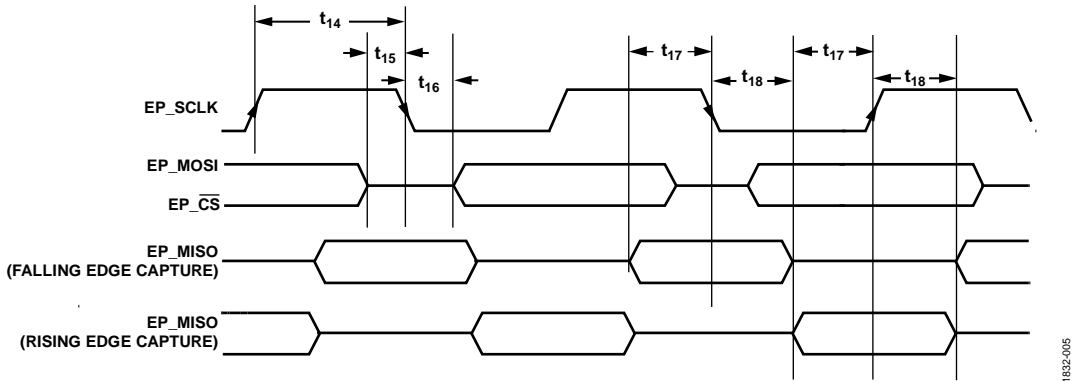

Figure 5. SPI Master Mode Timing (SPI Mode 0)

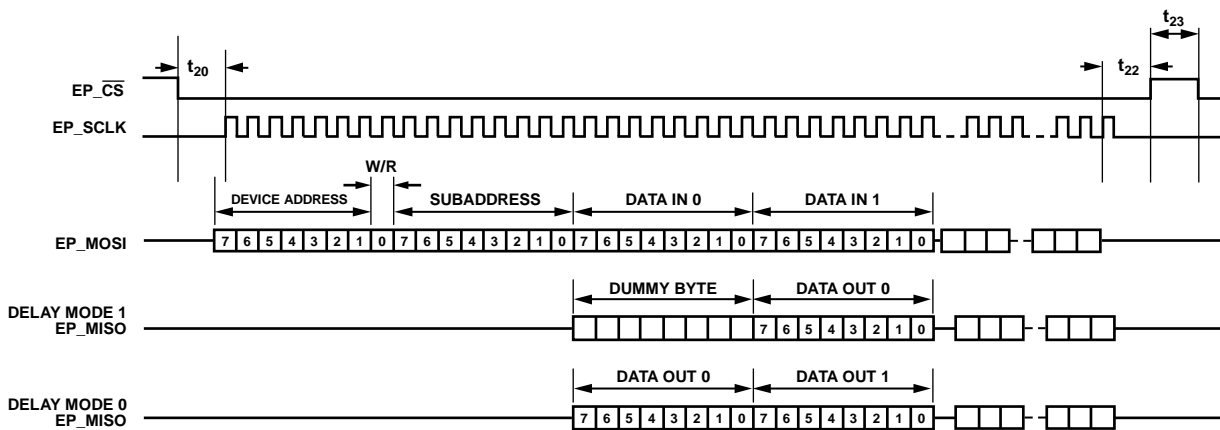

Figure 6. Detailed SPI Slave Timing Diagram (SPI Mode 0, CPOL = CPHA = 0)

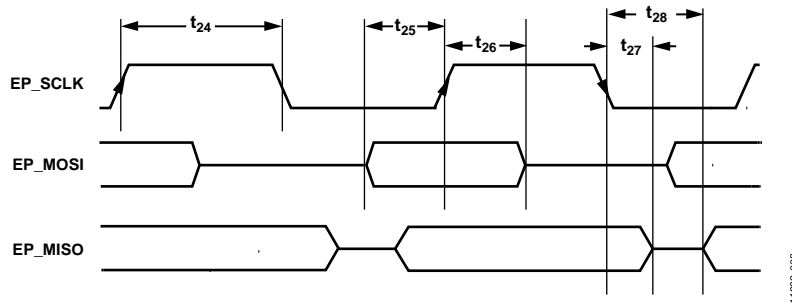
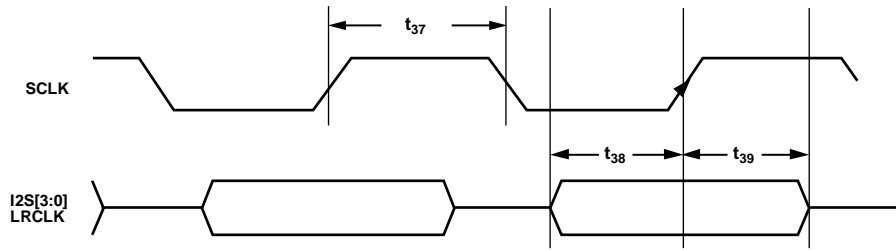

Figure 7. SPI Slave Mode Timing (SPI Mode 0)



AUDIO INPUT PORTS I²S SIGNAL ASSIGNMENT

INPUT PORT	SCLK	LRCLK	I ² S[3:0]
AP1_IN	AP1_IN_SCLK	AP1_IN5	AP1_IN[4:1]
AP2_IN	AP2_IN_SCLK	AP2_IN5	AP2_IN[4:1]

Figure 8. I²S Input Timing

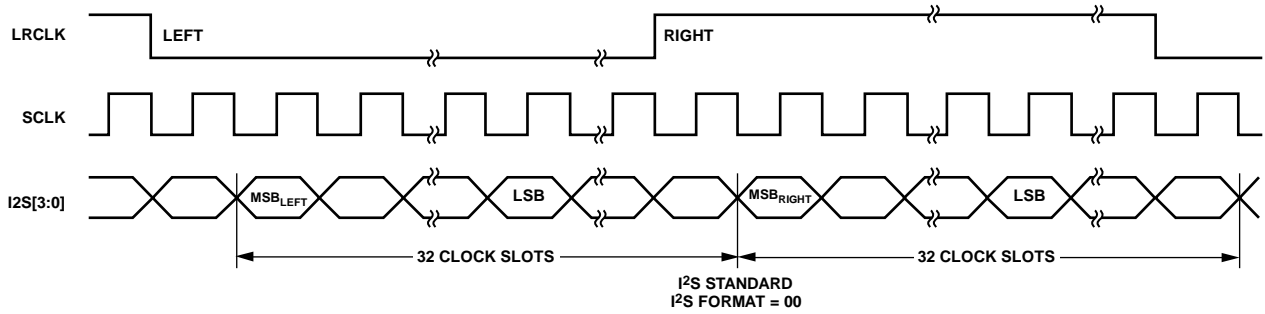

Figure 9. I²S Standard Audio, Data Width 16 to 24 Bits per Channel

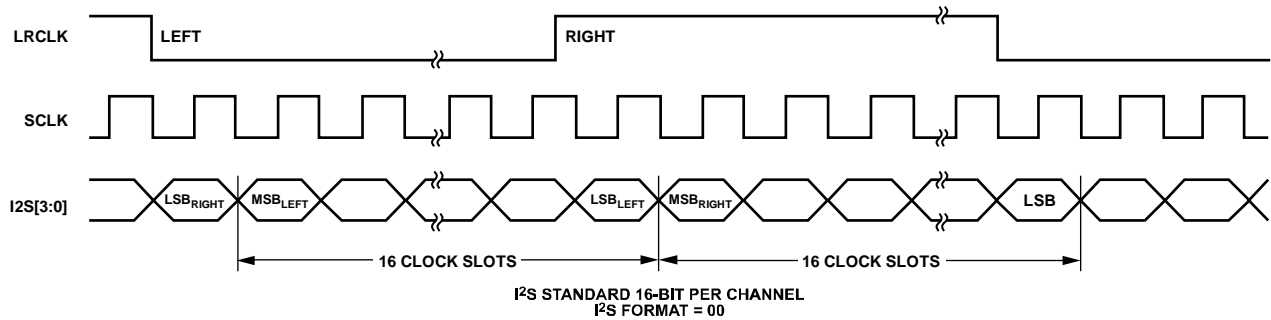

Figure 10. I²S Standard Audio, 16-Bit Samples Only

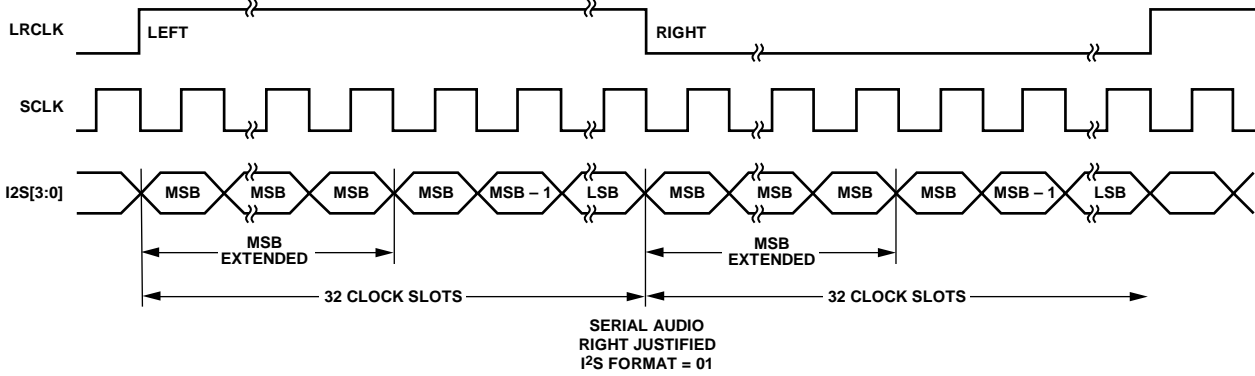

Figure 11. Serial Audio, Right-Justified

11832-015

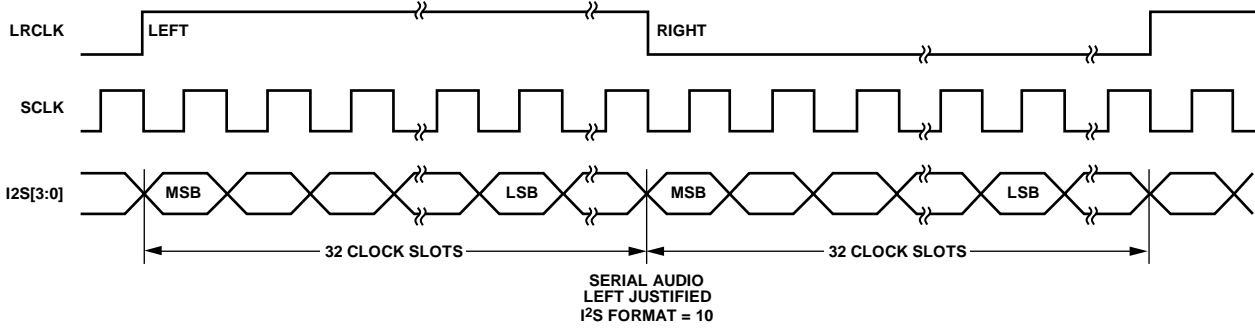

Figure 12. Serial Audio, Left-Justified

11832-016

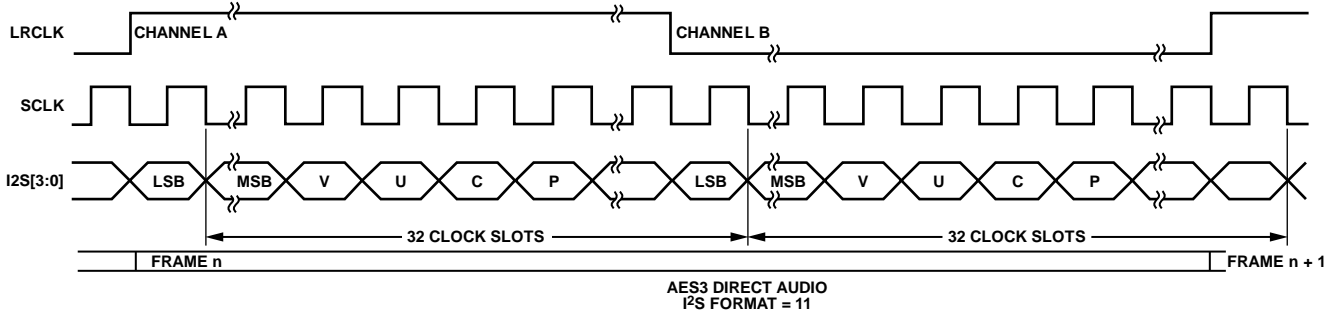
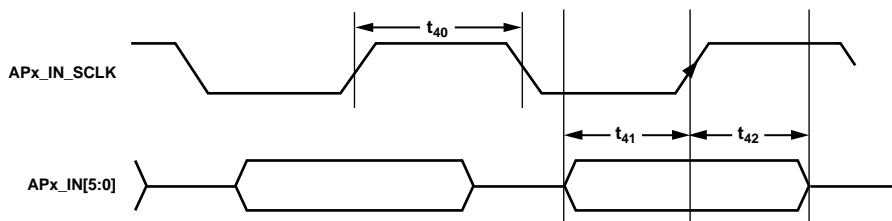

Figure 13. AES3 Direct Audio

11832-017



- NOTES
1. APx REFERS TO THE AUDIO INPUT PORTS AP1_IN AND AP2_IN.

Figure 14. DSD Input Timing

11832-018

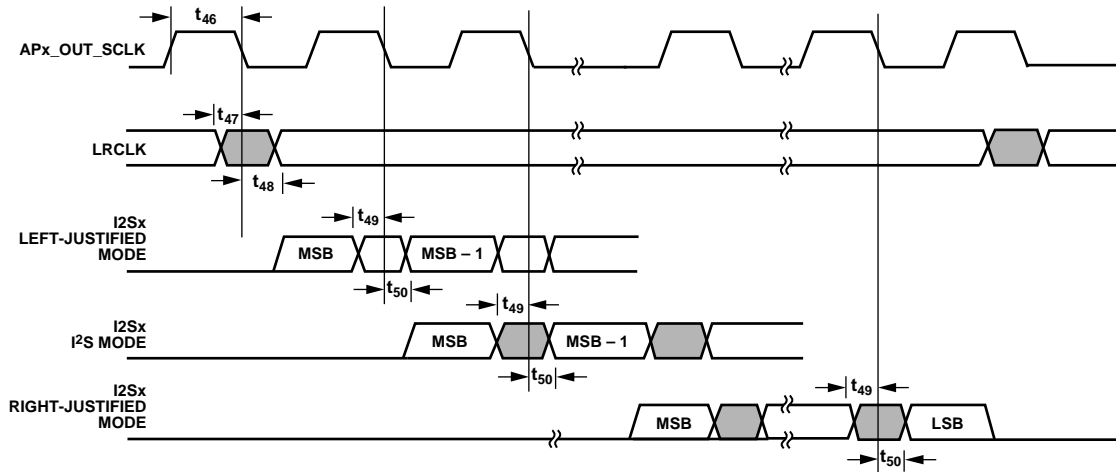

- NOTES
1. APx REFERS TO THE AUDIO OUTPUT PORTS AP1_OUT AND AP2_OUT.
 2. LRCLK IS A SIGNAL ACCESSIBLE VIA APx_OUT5.
 3. I2Sx ARE SIGNALS ACCESSIBLE VIA APx_OUT1 TO APx_OUT4.

Figure 15. I2S Output Timing

11832-020

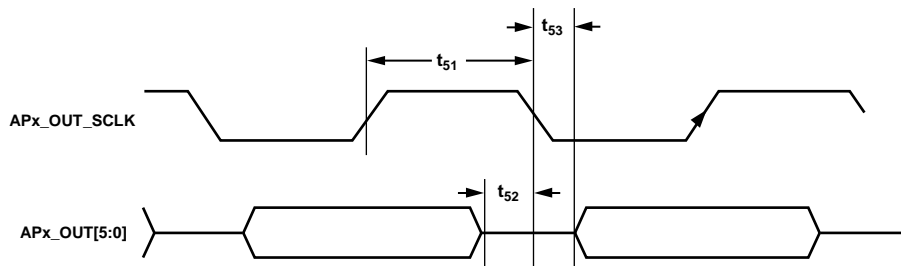

- NOTES
1. APx REFERS TO THE AUDIO OUTPUT PORTS AP1_OUT AND AP2_OUT.

Figure 16. DSD Output Timing

11832-021

POWER SPECIFICATIONS

Table 3.

Parameter	Symbol	Min	Typ	Max	Unit
POWER SUPPLIES					
HDMI TxA Analog Power Supply	AVDD_TXA	1.71	1.8	1.89	V
HDMI TxB Analog Power Supply	AVDD_TXB	1.71	1.8	1.89	V
Comparator Power Supply	CVDD	1.71	1.8	1.89	V
Digital Power Supply	DVDD	1.71	1.8	1.89	V
Digital I/O Power Supply	DVDDIO	3.14	3.3	3.46	V
PLL Power Supply	PVDD	1.71	1.8	1.89	V
HDMI TxA PLL Power Supply	PVDD_TXA	1.71	1.8	1.89	V
HDMI TxB PLL Power Supply	PVDD_TXB	1.71	1.8	1.89	V
Termination Power Supply	TVDD	3.14	3.3	3.46	V
CURRENT CONSUMPTION—MUX MODE^{1, 2}					
HDMI TxA Analog Power Supply	I _{AVDD_TXA}		23.2		mA
HDMI TxB Analog Power Supply	I _{AVDD_TXB}		23.2		mA
Comparator Power Supply	I _{CVDD}		196		mA
Digital Core Power Supply	I _{DVDD}		326.1		mA
Digital I/O Power Supply	I _{DVDDIO}		0.1		mA
PLL Power Supply	I _{PVDD}		69.7		mA
HDMI TxA PLL Power Supply	I _{PVDD_TXA}		71.5		mA
HDMI TxB PLL Power Supply	I _{PVDD_TXB}		71.5		mA
Termination Power Supply	I _{TVDD}		116		mA
CURRENT CONSUMPTION—AUDIO EXTRACT/ AUDIO INSERT MODE^{1, 3}					
HDMI TxA Analog Power Supply	I _{AVDD_TXA}		26.2		mA
HDMI TxB Analog Power Supply	I _{AVDD_TXB}		26.2		mA
Comparator Power Supply	I _{CVDD}		184		mA
Digital Core Power Supply	I _{DVDD}		436.0		mA
Digital I/O Power Supply	I _{DVDDIO}		0.05		mA
PLL Power Supply	I _{PVDD}		64		mA
HDMI TxA PLL Power Supply	I _{PVDD_TXA}		71.1		mA
HDMI TxB PLL Power Supply	I _{PVDD_TXB}		71.1		mA
Termination Power Supply	I _{TVDD}		115		mA
CURRENT CONSUMPTION—SPLITTER MODE^{1, 4}					
HDMI TxA Analog Power Supply	I _{AVDD_TXA}		26.2		mA
HDMI TxB Analog Power Supply	I _{AVDD_TXB}		26.2		mA
Comparator Power Supply	I _{CVDD}		93		mA
Digital Core Power Supply	I _{DVDD}		243.5		mA
Digital I/O Power Supply	I _{DVDDIO}		0.05		mA
PLL Power Supply	I _{PVDD}		33.5		mA
HDMI TxA PLL Power Supply	I _{PVDD_TXA}		71.1		mA
HDMI TxB PLL Power Supply	I _{PVDD_TXB}		71.1		mA
Termination Power Supply	I _{TVDD}		115		mA
CURRENT CONSUMPTION—POWER-DOWN MODE 0^{1, 5}					
HDMI TxA Analog Power Supply	I _{AVDD_TXA}		0.65		mA
HDMI TxB Analog Power Supply	I _{AVDD_TXB}		0.65		mA
Comparator Power Supply	I _{CVDD}		0.84		mA
Digital Core Power Supply	I _{DVDD}		0.25		mA
Digital I/O Power Supply	I _{DVDDIO}		0.21		mA
PLL Power Supply	I _{PVDD}		0.02		mA
HDMI TxA PLL Power Supply	I _{PVDD_TXA}		0.05		mA
HDMI TxB PLL Power Supply	I _{PVDD_TXB}		0.05		mA
Termination Power Supply	I _{TVDD}		0.14		mA

Parameter	Symbol	Min	Typ	Max	Unit
CURRENT CONSUMPTION—POWER-DOWN MODE 1^{1,6}					
HDMI TxA Analog Power Supply	I _{AVDD_TXA}		0.95		mA
HDMI TxB Analog Power Supply	I _{AVDD_TXB}		0.95		mA
Comparator Power Supply	I _{CVDD}		0.84		mA
Digital Core Power Supply	I _{DVDD}		0.95		mA
Digital I/O Power Supply	I _{DVDDIO}		0.21		mA
PLL Power Supply	I _{PVDD}		0.02		mA
HDMI TxA PLL Power Supply	I _{PVDD_TXA}		0.05		mA
HDMI TxB PLL Power Supply	I _{PVDD_TXB}		0.05		mA
Termination Power Supply	I _{TVDD}		0.14		mA
CURRENT CONSUMPTION—EXAMPLE MAXIMUM OPERATING MODE^{1,7}					
HDMI TxA Analog Power Supply	I _{AVDD_TXA}			31.00	mA
HDMI TxB Analog Power Supply	I _{AVDD_TXB}			31.00	mA
Comparator Power Supply	I _{CVDD}			213.00	mA
Digital Core Power Supply	I _{DVDD}			530.00	mA
Digital I/O Power Supply	I _{DVDDIO}			0.20	mA
PLL Power Supply	I _{PVDD}			75.00	mA
HDMI TxA PLL Power Supply	I _{PVDD_TXA}			80.00	mA
HDMI TxB PLL Power Supply	I _{PVDD_TXB}			80.00	mA
Termination Power Supply	I _{TVDD}			128.00	mA

¹ Data recorded during lab characterization. Typical current consumption values are recorded with nominal voltage supply levels and at room temperature.

² ADV7626 configured in mux mode with two active HDMI Rx inputs and two HDMI Tx outputs in use. 4k × 2k at 30 Hz video format with pseudo random test pattern applied to each HDMI Rx input port. HDMI Rx termination closed on the two HDMI Rx input ports. HDMI Tx source termination enabled.

³ ADV7626 configured in audio extract/audio insert mode with two active HDMI Rx inputs and two HDMI Tx outputs in use. Audio extracted from both HDMI Rx inputs and output on AP1_OUT and AP2_OUT. Audio inserted on HDMI Tx outputs from AP1_IN and AP2_IN input ports, respectively. HBR audio used. 4k × 2k at 30 Hz video format with pseudo random test pattern applied to both HDMI Rx input ports. HDMI Rx port termination closed on the two HDMI Rx input ports. HDMI Tx source termination enabled. OSD not enabled.

⁴ ADV7626 configured in splitter mode with one HDMI Rx input and two HDMI Tx outputs in use. 4k × 2k at 30 Hz video format with pseudo random test pattern applied to one HDMI Rx input and output on both HDMI Tx outputs using splitter mode. HBR audio from HDMI Rx input inserted on the HDMI Tx outputs. No audio extraction. HDMI Rx port termination closed on the active HDMI Rx input port and open on the unused HDMI Rx input port. HDMI Tx source termination enabled. OSD enabled and blended on both HDMI Tx outputs using splitter mode.

⁵ ADV7626 configured in Power-Down Mode 0 with two HDMI Rx inputs and two HDMI Tx outputs connected. In Power-Down Mode 0, all blocks are powered down except for the I²C slave.

⁶ ADV7626 configured in Power-Down Mode 1 with two HDMI Rx inputs and two HDMI Tx outputs connected. In Power-Down Mode 1, all blocks are powered down except for the I²C slave and the CEC (to monitor wake-up interrupts).

⁷ ADV7626 configured in an example maximum operating mode with two active HDMI Rx inputs and two HDMI Tx outputs in use. HBR audio from the two active HDMI Rx inputs inserted on the corresponding HDMI Tx outputs. No audio extraction. 4k × 2k at 30 Hz video format with pseudo random test pattern applied to both HDMI Rx input ports. HDMI Rx port termination closed on the two HDMI Rx input ports. HDMI Tx source termination enabled. OSD not enabled. Maximum current consumption values recorded with maximum power supply levels at device maximum operating temperature.

ABSOLUTE MAXIMUM RATINGS

Table 4.

Parameter	Rating
AVDD_TXA to GND	2.2 V
AVDD_TXB to GND	2.2 V
CVDD to GND	2.2 V
DVDD to GND	2.2 V
PVDD to GND	2.2 V
PVDD_TXA to GND	2.2 V
PVDD_TXB to GND	2.2 V
DVDDIO to GND	4.0 V
TVDD to GND	4.0 V
Digital Inputs Voltage to GND	GND – 0.3 V to DVDDIO + 0.3 V up to a maximum of 4.0 V
5 V Tolerant Digital Inputs to GND ¹	5.5 V
Digital Outputs Voltage to GND	GND – 0.3 V to DVDDIO + 0.3 V up to a maximum of 4.0 V
XTAL+, XTAL– Pins	–0.3 V to PVDD + 0.3 V
Maximum Junction Temperature (T _{JMAX})	125°C
Storage Temperature Range	–65°C to +150°C
Infrared Reflow, Soldering (20 sec)	260°C

¹ The following inputs are 5 V tolerant: DDC_SCL_RXA, DDC_SDA_RXA, DDC_SCL_RXB, DDC_SDA_RXB, RXA_5V, RXB_5V, CEC_A, DDC_SCL_TXA, DDC_SDA_TXA, TXA_HPD_ARC–, TXA_ARC+, CEC_B, DDC_SCL_TXB, DDC_SDA_TXB, TXB_HPD_ARC–, and TXB_ARC+.

Stresses above those listed under Absolute Maximum Ratings may cause permanent damage to the device. This is a stress rating only; functional operation of the device at these or any other conditions above those indicated in the operational section of this specification is not implied. Exposure to absolute maximum rating conditions for extended periods may affect device reliability.

PACKAGE THERMAL PERFORMANCE

To reduce power consumption when using the [ADV7626](#), the user is advised to turn off unused sections of the device.

Due to printed circuit board (PCB) metal variation and, therefore, variation in PCB heat conductivity, the value of θ_{JA} may differ for various PCBs. The most efficient measurement solution is obtained using the package surface temperature to estimate the die temperature because this solution eliminates the variance associated with the θ_{JA} value.

Do not exceed the maximum junction temperature (T_{JMAX}) of 125°C. The following equation calculates the junction temperature using the measured package surface temperature and applies only when no heat sink is used on the device under test (DUT):

$$T_J = T_S + (\Psi_{JT} \times W_{TOTAL})$$

where:

T_S is the package surface temperature (°C).

$\Psi_{JT} = 0.41^\circ\text{C}/\text{W}$ for the 260-ball CSP_BGA (based on 2s2p test board defined in the JEDEC specification).

$$W_{TOTAL} = ((PVDD \times I_{PVDD}) + (PVDD_TXA \times I_{PVDD_TXA}) + (PVDD_TXB \times I_{PVDD_TXB}) + (TVDD \times I_{TVDD}) + (CVDD \times I_{CVDD}) + (AVDD_TXA \times I_{AVDD_TXA}) + (AVDD_TXB \times I_{AVDD_TXB}) + (DVDD \times I_{DVDD}) + (DVDDIO \times I_{DVDDIO}))$$

Note that this calculation assumes a configuration of two active HDMI Rx inputs and two active HDMI Tx outputs, where termination is open on the unused Rx input ports.

A configuration of one active HDMI Rx input and two active HDMI Tx outputs (splitter mode) results in approximately 112 mW extra power dissipation on chip.

ESD CAUTION



ESD (electrostatic discharge) sensitive device. Charged devices and circuit boards can discharge without detection. Although this product features patented or proprietary protection circuitry, damage may occur on devices subjected to high energy ESD. Therefore, proper ESD precautions should be taken to avoid performance degradation or loss of functionality.

PIN CONFIGURATION AND FUNCTION DESCRIPTIONS

A	GND	RXA_2+	RXA_1+	RXA_0+	RXA_C+	CVDD	RXB_2+	RXB_1+	RXB_0+	RXB_C+	CVDD	NC	NC	NC	NC	CVDD	NC	GND
B	GND	RXA_2-	RXA_1-	RXA_0-	RXA_C-	CVDD	RXB_2-	RXB_1-	RXB_0-	RXB_C-	CVDD	NC	NC	NC	NC	CVDD	NC	GND
C	GND	CVDD	CVDD	TVDD	TVDD	GND	GND	TVDD	TVDD	GND	GND	TVDD	TVDD	GND	GND	CVDD	GND	GND
D	INT1	INT2	SCL	SDA	\overline{CS}	RXA_5V	RXA_HPA	DDC_SCL_RXA	DDC_SDA_RXA	DDC_SCL_RXB	DDC_SDA_RXB	RXB_HPA	RXB_5V	NC	TEST6	TVDD	NC	NC
E	AP1_OUT0	AP1_OUT1	ALSB	\overline{RESET}											NC	TVDD	NC	NC
F	AP1_OUT2	AP1_OUT3	AP2_OUT0	AP2_OUT1											NC	GND	NC	NC
G	AP1_OUT4	AP1_OUT5	AP2_OUT2	AP2_OUT3			DVDD	DVDD	DVDD	DVDD	DVDD	TEST5			TEST7	GND	NC	NC
H	AP1_OUT_MCLK	AP1_OUT_SCLK	AP2_OUT4	AP2_OUT5			DVDDIO	GND	GND	GND	GND	GND			NC	GND	CVDD	CVDD
J	AP2_OUT_MCLK	AP2_OUT_SCLK	TEST9	TEST10			DVDDIO	GND	GND	GND	GND	GND			TEST8	TVDD	NC	NC
K	GND	GND	TEST11	TEST12			GND	GND	GND	GND	GND	GND			NC	TVDD	NC	NC
L	XTAL+	XTAL-	TEST13	TEST14			GND	GND	GND	GND	GND	GND			NC	GND	NC	NC
M	PVDD	PVDD	TEST3	TEST2			GND	GND	GND	GND	GND	GND			NC	GND	NC	NC
N	GND	GND	PVDD_TXA	PVDD_TXA											GND	GND	CVDD	CVDD
P	TXA_C-	TXA_C+	GND	R_TXA											TEST15	TEST16	TEST4	TEST1
R	TXA_0-	TXA_0+	GND	AVDD_TXA	TXB_HPD_ARC-	R_TXB	GND	TXB_ARC+	DDC_SDA_TXB	DDC_SCL_TXB	CEC_B	DVDDIO	EP_CS	AP2_IN_SCLK	AP2_IN4	AP2_IN2	AP2_IN0	TEST17
T	TXA_1-	TXA_1+	GND	AVDD_TXA	CEC_A	GND	GND	GND	GND	AVDD_TXB	AVDD_TXB	DVDDIO	EP_SCLK	AP2_IN_MCLK	AP2_IN5	AP2_IN3	AP2_IN1	TEST18
U	TXA_2-	TXA_2+	GND	DDC_SCL_TXA	TXA_ARC+	PVDD_TXB	GND	TXB_C+	TXB_0+	TXB_1+	TXB_2+	GND	EP_MOSI	AP1_IN_SCLK	AP1_IN4	AP1_IN2	AP1_IN0	GND
V	GND	GND	GND	DDC_SDA_TXA	TXA_HPD_ARC-	PVDD_TXB	GND	TXB_C-	TXB_0-	TXB_1-	TXB_2-	GND	EP_MISO	AP1_IN_MCLK	AP1_IN5	AP1_IN3	AP1_IN1	GND
	1	2	3	4	5	6	7	8	9	10	11	12	13	14	15	16	17	18

Figure 17. Pin Configuration

Table 5. Pin Function Descriptions

Pin No.	Mnemonic	Function	Description
A1	GND	Ground	Ground.
A2	RXA_2+	HDMI Rx input	HDMI RxA Channel 2 True Input.
A3	RXA_1+	HDMI Rx input	HDMI RxA Channel 1 True Input.
A4	RXA_0+	HDMI Rx input	HDMI RxA Channel 0 True Input.
A5	RXA_C+	HDMI Rx input	HDMI RxA Clock True Input.
A6	CVDD	Power	Comparator Power Supply (1.8 V).
A7	RXB_2+	HDMI Rx input	HDMI RxB Channel 2 True Input.
A8	RXB_1+	HDMI Rx input	HDMI RxB Channel 1 True Input.
A9	RXB_0+	HDMI Rx input	HDMI RxB Channel 0 True Input.
A10	RXB_C+	HDMI Rx input	HDMI RxB Clock True Input.
A11	CVDD	Power	Comparator Power Supply (1.8 V).
A12	NC	Do not connect	Leave this pin floating.

Pin No.	Mnemonic	Function	Description
A13	NC	Do not connect	Leave this pin floating.
A14	NC	Do not connect	Leave this pin floating.
A15	NC	Do not connect	Leave this pin floating.
A16	CVDD	Power	Comparator Power Supply (1.8 V).
A17	NC	Do not connect	Leave this pin floating.
A18	GND	Ground	Ground.
B1	GND	Ground	Ground.
B2	RXA_2-	HDMI Rx input	HDMI RxA Channel 2 Complement Input.
B3	RXA_1-	HDMI Rx input	HDMI RxA Channel 1 Complement Input.
B4	RXA_0-	HDMI Rx input	HDMI RxA Channel 0 Complement Input.
B5	RXA_C-	HDMI Rx input	HDMI RxA Clock Complement Input.
B6	CVDD	Power	Comparator Power Supply (1.8 V).
B7	RXB_2-	HDMI Rx input	HDMI RxB Channel 2 Complement Input.
B8	RXB_1-	HDMI Rx input	HDMI RxB Channel 1 Complement Input.
B9	RXB_0-	HDMI Rx input	HDMI RxB Channel 0 Complement Input.
B10	RXB_C-	HDMI Rx input	HDMI RxB Clock Complement Input.
B11	CVDD	Power	Comparator Power Supply (1.8 V).
B12	NC	Do not connect	Leave this pin floating.
B13	NC	Do not connect	Leave this pin floating.
B14	NC	Do not connect	Leave this pin floating.
B15	NC	Do not connect	Leave this pin floating.
B16	CVDD	Power	Comparator Power Supply (1.8 V).
B17	NC	Do not connect	Leave this pin floating.
B18	GND	Ground	Ground.
C1	GND	Ground	Ground.
C2	CVDD	Power	Comparator Power Supply (1.8 V).
C3	CVDD	Power	Comparator Power Supply (1.8 V).
C4	TVDD	Power	HDMI Rx Terminator Supply Voltage (3.3 V).
C5	TVDD	Power	HDMI Rx Terminator Supply Voltage (3.3 V).
C6	GND	Ground	Ground.
C7	GND	Ground	Ground.
C8	TVDD	Power	HDMI Rx Terminator Supply Voltage (3.3 V).
C9	TVDD	Power	HDMI Rx Terminator Supply Voltage (3.3 V).
C10	GND	Ground	Ground.
C11	GND	Ground	Ground.
C12	TVDD	Power	HDMI Rx Terminator Supply Voltage (3.3 V).
C13	TVDD	Power	HDMI Rx Terminator Supply Voltage (3.3 V).
C14	GND	Ground	Ground.
C15	GND	Ground	Ground.
C16	CVDD	Power	Comparator Power Supply (1.8 V).
C17	GND	Ground	Ground.
C18	GND	Ground	Ground.
D1	INT1	Control	Interrupt Output. This pin can be active low or high. When an unmasked status bit changes, an interrupt is generated on this pin.
D2	INT2	Control	Interrupt Output. This pin can be active low or high. When an unmasked status bit changes, an interrupt is generated on this pin.
D3	SCL	I ² C control	I ² C Clock Input. This pin is open drain; connect this pin to a 3.3 V supply using a 4.7 k Ω resistor.
D4	SDA	I ² C control	I ² C Data Input. This pin is open drain; connect this pin to a 3.3 V supply using a 4.7 k Ω resistor.
D5	$\overline{\text{CS}}$	Digital input	Chip Select Pin. This pin must be set low or left floating for the chip to process I ² C messages that are destined for the ADV7626. The ADV7626 ignores I ² C messages when this pin is high.
D6	RXA_5V	HDMI Rx input	HDMI RxA 5 V Detect Pin.

Pin No.	Mnemonic	Function	Description
D7	RXA_HPA	HDMI Rx output	HDMI RxA Hot Plug Assert.
D8	DDC_SCL_RXA	HDMI Rx DDC	HDCP Slave Serial Clock for HDMI RxA.
D9	DDC_SDA_RXA	HDMI Rx DDC	HDCP Slave Serial Data for HDMI RxA.
D10	DDC_SCL_RXB	HDMI Rx DDC	HDCP Slave Serial Clock for HDMI RxB.
D11	DDC_SDA_RXB	HDMI Rx DDC	HDCP Slave Serial Data for HDMI RxB.
D12	RXB_HPA	HDMI Rx output	HDMI RxB Hot Plug Assert.
D13	RXB_5V	HDMI Rx input	HDMI RxB 5 V Detect Pin.
D14	NC	Do not connect	Leave this pin floating.
D15	TEST6	Test pin	Connect this pin to ground using a 4.7 k Ω resistor.
D16	TVDD	Power	HDMI Rx Terminator Supply Voltage (3.3 V).
D17	NC	Do not connect	Leave this pin floating.
D18	NC	Do not connect	Leave this pin floating.
E1	AP1_OUT0	Audio output	Audio Output Port 1, Output 0.
E2	AP1_OUT1	Audio output	Audio Output Port 1, Output 1.
E3	ALSB	I ² C control	Pin to set the I ² C address of the I/O register map for the device. When the ALSB pin is tied low, the I/O register map I ² C address is 0xB0. When the ALSB pin is tied high, the I/O register map I ² C address is 0xB2.
E4	$\overline{\text{RESET}}$	Miscellaneous digital	Reset Pin.
E15	NC	Do not connect	Leave this pin floating.
E16	TVDD	Power	HDMI Rx Terminator Supply Voltage (3.3 V).
E17	NC	Do not connect	Leave this pin floating.
E18	NC	Do not connect	Leave this pin floating.
F1	AP1_OUT2	Audio output	Audio Output Port 1, Output 2.
F2	AP1_OUT3	Audio output	Audio Output Port 1, Output 3.
F3	AP2_OUT0	Audio output	Audio Output Port 2, Output 0.
F4	AP2_OUT1	Audio output	Audio Output Port 2, Output 1.
F15	NC	Do not connect	Leave this pin floating.
F16	GND	Ground	Ground.
F17	NC	Do not connect	Leave this pin floating.
F18	NC	Do not connect	Leave this pin floating.
G1	AP1_OUT4	Audio output	Audio Output Port 1, Output 4.
G2	AP1_OUT5	Audio output	Audio Output Port 1, Output 5.
G3	AP2_OUT2	Audio output	Audio Output Port 2, Output 2.
G4	AP2_OUT3	Audio output	Audio Output Port 2, Output 3.
G7	DVDD	Power	Digital Power Supply (1.8 V).
G8	DVDD	Power	Digital Power Supply (1.8 V).
G9	DVDD	Power	Digital Power Supply (1.8 V).
G10	DVDD	Power	Digital Power Supply (1.8 V).
G11	DVDD	Power	Digital Power Supply (1.8 V).
G12	TEST5	Test pin	Test Pin 5. Leave this pin floating.
G15	TEST7	Test pin	Connect this pin to ground using a 4.7 k Ω resistor.
G16	GND	Ground	Ground.
G17	NC	Do not connect	Leave this pin floating.
G18	NC	Do not connect	Leave this pin floating.
H1	AP1_OUT_MCLK	Audio output	Audio Output Port 1, MCLK.
H2	AP1_OUT_SCLK	Audio output	Audio Output Port 1, SCLK.
H3	AP2_OUT4	Audio output	Audio Output Port 2, Output 4.
H4	AP2_OUT5	Audio output	Audio Output Port 2, Output 5.
H7	DVDDIO	Power	Digital Interface Supply (3.3 V).
H8	GND	Ground	Ground.
H9	GND	Ground	Ground.
H10	GND	Ground	Ground.
H11	GND	Ground	Ground.

Pin No.	Mnemonic	Function	Description
H12	GND	Ground	Ground.
H15	NC	Do not connect	Leave this pin floating.
H16	GND	Ground	Ground.
H17	CVDD	Power	Comparator Power Supply (1.8 V).
H18	CVDD	Power	Comparator Power Supply (1.8 V).
J1	AP2_OUT_MCLK	Audio output	Audio Output Port 2, MCLK.
J2	AP2_OUT_SCLK	Audio output	Audio Output Port 2, SCLK.
J3	TEST9	Test pin	Connect this pin to ground using a 4.7 k Ω resistor.
J4	TEST10	Test pin	Connect this pin to ground using a 4.7 k Ω resistor.
J7	DVDDIO	Power	Digital Interface Supply (3.3 V).
J8	GND	Ground	Ground.
J9	GND	Ground	Ground.
J10	GND	Ground	Ground.
J11	GND	Ground	Ground.
J12	GND	Ground	Ground.
J15	TEST8	Test pin	Connect this pin to ground using a 4.7 k Ω resistor.
J16	TVDD	Power	HDMI Rx Terminator Supply Voltage (3.3 V).
J17	NC	Do not connect	Leave this pin floating.
J18	NC	Do not connect	Leave this pin floating.
K1	GND	Ground	Ground.
K2	GND	Ground	Ground.
K3	TEST11	Test pin	Connect this pin to ground using a 4.7 k Ω resistor.
K4	TEST12	Test pin	Connect this pin to ground using a 4.7 k Ω resistor.
K7	GND	Ground	Ground.
K8	GND	Ground	Ground.
K9	GND	Ground	Ground.
K10	GND	Ground	Ground.
K11	GND	Ground	Ground.
K12	GND	Ground	Ground.
K15	NC	Do not connect	Leave this pin floating.
K16	TVDD	Power	HDMI Rx Terminator Supply Voltage (3.3 V).
K17	NC	Do not connect	Leave this pin floating.
K18	NC	Do not connect	Leave this pin floating.
L1	XTAL+	Miscellaneous digital	ADV7626 Crystal Input.
L2	XTAL-	Miscellaneous digital	ADV7626 Crystal Output.
L3	TEST13	Test pin	Connect this pin to ground using a 4.7 k Ω resistor.
L4	TEST14	Test pin	Connect this pin to ground using a 4.7 k Ω resistor.
L7	GND	Ground	Ground.
L8	GND	Ground	Ground.
L9	GND	Ground	Ground.
L10	GND	Ground	Ground.
L11	GND	Ground	Ground.
L12	GND	Ground	Ground.
L15	NC	Do not connect	Leave this pin floating.
L16	GND	Ground	Ground.
L17	NC	Do not connect	Leave this pin floating.
L18	NC	Do not connect	Leave this pin floating.
M1	PVDD	Power	PLL Digital Supply (1.8 V).
M2	PVDD	Power	PLL Digital Supply (1.8 V).
M3	TEST3	Test pin	Test Pin 3. Leave this pin floating.
M4	TEST2	Test pin	Test Pin 2. Leave this pin floating.
M7	GND	Ground	Ground.
M8	GND	Ground	Ground.

Pin No.	Mnemonic	Function	Description
M9	GND	Ground	Ground.
M10	GND	Ground	Ground.
M11	GND	Ground	Ground.
M12	GND	Ground	Ground.
M15	NC	Do not connect	Leave this pin floating.
M16	GND	Ground	Ground.
M17	NC	Do not connect	Leave this pin floating.
M18	NC	Do not connect	Leave this pin floating.
N1	GND	Ground	Ground.
N2	GND	Ground	Ground.
N3	PVDD_TXA	Power	HDMI TxA PLL Power Supply (1.8 V).
N4	PVDD_TXA	Power	HDMI TxA PLL Power Supply (1.8 V).
N15	GND	Ground	Ground.
N16	GND	Ground	Ground.
N17	CVDD	Power	Comparator Power Supply (1.8 V).
N18	CVDD	Power	Comparator Power Supply (1.8 V).
P1	TXA_C-	HDMI Tx output	HDMI TxA Clock Complement Output.
P2	TXA_C+	HDMI Tx output	HDMI TxA Clock True Output.
P3	GND	Ground	Ground.
P4	R_TXA	HDMI Tx input	This pin sets the internal reference currents for HDMI TxA. Place a 470 Ω resistor (1% tolerance) between this pin and GND. Place the external resistor as close as possible to the ADV7626 .
P15	TEST15	Test pin	Connect this pin to ground using a 4.7 k Ω resistor.
P16	TEST16	Test pin	Connect this pin to ground using a 4.7 k Ω resistor.
P17	TEST4	Test pin	Test Pin 4. Leave this pin floating.
P18	TEST1	Test pin	Test Pin 1. Leave this pin floating.
R1	TXA_0-	HDMI Tx output	HDMI TxA Channel 0 Complement Output.
R2	TXA_0+	HDMI Tx output	HDMI TxA Channel 0 True Output.
R3	GND	Ground	Ground.
R4	AVDD_TXA	Power	HDMI TxA Analog Supply (1.8 V).
R5	TXB_HPD_ARC-	HDMI Tx input	HDMI TxB Hot Plug Detect (HPD) Signal and Audio Return Channel Complement Input.
R6	R_TXB	HDMI Tx input	This pin sets the internal reference currents for HDMI TxB. Place a 470 Ω resistor (1% tolerance) between this pin and GND. Place the external resistor as close as possible to the ADV7626 .
R7	GND	Ground	Ground.
R8	TXB_ARC+	HDMI Tx input	HDMI TxB Audio Return Channel True Input.
R9	DDC_SDA_TXB	HDMI Tx DDC	HDCP Slave Serial Data for HDMI TxB.
R10	DDC_SCL_TXB	HDMI Tx DDC	HDCP Slave Serial Clock for HDMI TxB.
R11	CEC_B	HDMI Tx CEC	HDMI TxB Consumer Electronics Control (CEC).
R12	DVDDIO	Power	Digital Interface Supply (3.3 V).
R13	EP_CS	Serial port control	SPI Chip Select Interface for the OSD.
R14	AP2_IN_SCLK	Audio input	Audio Input Port 2, SCLK.
R15	AP2_IN4	Audio input	Audio Input Port 2, Input 4.
R16	AP2_IN2	Audio input	Audio Input Port 2, Input 2.
R17	AP2_IN0	Audio input	Audio Input Port 2, Input 0.
R18	TEST17	Test pin	Connect this pin to ground using a 4.7 k Ω resistor.
T1	TXA_1-	HDMI Tx output	HDMI TxA Channel 1 Complement Output.
T2	TXA_1+	HDMI Tx output	HDMI TxA Channel 1 True Output.
T3	GND	Ground	Ground.
T4	AVDD_TXA	Power	HDMI TxA Analog Supply (1.8 V).
T5	CEC_A	HDMI Tx CEC	HDMI TxA Consumer Electronics Control (CEC).
T6	GND	Ground	Ground.
T7	GND	Ground	Ground.

Pin No.	Mnemonic	Function	Description
T8	GND	Ground	Ground.
T9	GND	Ground	Ground.
T10	AVDD_TXB	Power	HDMI TxB Analog Supply (1.8 V).
T11	AVDD_TXB	Power	HDMI TxB Analog Supply (1.8 V).
T12	DVDDIO	Power	Digital Interface Supply (3.3 V).
T13	EP_SCLK	Serial port control	SPI Clock Interface for the OSD.
T14	AP2_IN_MCLK	Audio input	Audio Input Port 2, MCLK.
T15	AP2_IN5	Audio input	Audio Input Port 2, Input 5.
T16	AP2_IN3	Audio input	Audio Input Port 2, Input 3.
T17	AP2_IN1	Audio input	Audio Input Port 2, Input 1.
T18	TEST18	Test pin	Connect this pin to ground using a 4.7 kΩ resistor.
U1	TXA_2-	HDMI Tx output	HDMI TxA Channel 2 Complement Output.
U2	TXA_2+	HDMI Tx output	HDMI TxA Channel 2 True Output.
U3	GND	Ground	Ground.
U4	DDC_SCL_TXA	HDMI Tx DDC	HDCP Slave Serial Clock for HDMI TxA.
U5	TXA_ARC+	HDMI Tx input	HDMI TxA Audio Return Channel True Input.
U6	PVDD_TXB	Power	HDMI TxB PLL Power Supply (1.8 V).
U7	GND	Ground	Ground.
U8	TXB_C+	HDMI Tx output	HDMI TxB Clock True Output.
U9	TXB_0+	HDMI Tx output	HDMI TxB Channel 0 True Output.
U10	TXB_1+	HDMI Tx output	HDMI TxB Channel 1 True Output.
U11	TXB_2+	HDMI Tx output	HDMI TxB Channel 2 True Output.
U12	GND	Ground	Ground.
U13	EP_MOSI	Serial port control	SPI Master Output/Slave Input for OSD.
U14	AP1_IN_SCLK	Audio input	Audio Input Port 1, SCLK.
U15	AP1_IN4	Audio input	Audio Input Port 1, Input 4.
U16	AP1_IN2	Audio input	Audio Input Port 1, Input 2.
U17	AP1_IN0	Audio input	Audio Input Port 1, Input 0.
U18	GND	Ground	Ground.
V1	GND	Ground	Ground.
V2	GND	Ground	Ground.
V3	GND	Ground	Ground.
V4	DDC_SDA_TXA	HDMI Tx DDC	HDCP Slave Serial Data for HDMI TxA.
V5	TXA_HPD_ARC-	HDMI Tx input	HDMI TxA Hot Plug Detect (HPD) Signal and Audio Return Channel Complement Input.
V6	PVDD_TXB	Power	HDMI TxB PLL Power Supply (1.8 V).
V7	GND	Ground	Ground.
V8	TXB_C-	HDMI Tx output	HDMI TxB Clock Complement Output.
V9	TXB_0-	HDMI Tx output	HDMI TxB Channel 0 Complement Output.
V10	TXB_1-	HDMI Tx output	HDMI TxB Channel 1 Complement Output.
V11	TXB_2-	HDMI Tx output	HDMI TxB Channel 2 Complement Output.
V12	GND	Ground	Ground.
V13	EP_MISO	Serial port control	SPI Master Input/Slave Output for OSD.
V14	AP1_IN_MCLK	Audio input	Audio Input Port 1, MCLK.
V15	AP1_IN5	Audio input	Audio Input Port 1, Input 5.
V16	AP1_IN3	Audio input	Audio Input Port 1, Input 3.
V17	AP1_IN1	Audio input	Audio Input Port 1, Input 1.
V18	GND	Ground	Ground.

POWER SUPPLY RECOMMENDATIONS

POWER-UP SEQUENCE

The power-up sequence for the [ADV7626](#) is as follows:

1. Hold the `RESET` pin low.
2. Power up the 3.3 V supplies (DVDDIO and TVDD).
3. After the 3.3 V supplies reach their minimum recommended value of 3.14 V, wait at least 20 ms before powering up the 1.8 V supplies.
4. Power up the 1.8 V supplies (AVDD_TXA, AVDD_TXB, CVDD, DVDD, PVDD, PVDD_TXA, and PVDD_TXB). These supplies should be powered up at the same time; that is, there should be a difference of less than 0.3 V between them.
5. Release the `RESET` pin after all supplies are established.

After power-up, a complete reset is recommended. This reset can be performed by the system microcontroller.

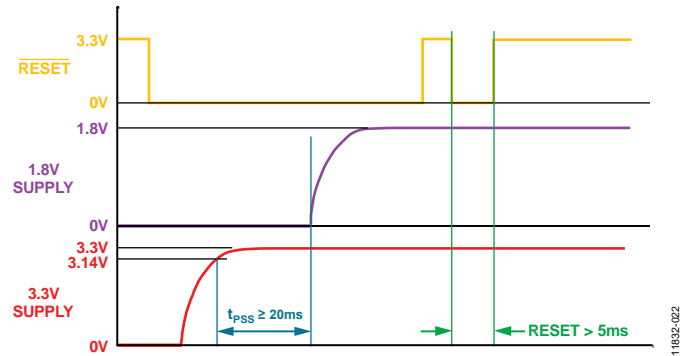

Figure 18. [ADV7626](#) Supply Power-Up Sequence

POWER-DOWN SEQUENCE

The [ADV7626](#) supplies can be deasserted simultaneously as long as DVDDIO or TVDD does not fall below a lower rated supply.

THEORY OF OPERATION

HDMI RECEIVER

The [ADV7626](#) front end incorporates two HDMI receivers capable of receiving all HDTV formats up to 3 GHz (4k × 2k at 24 Hz/25 Hz/30 Hz). The HDMI receivers also support HDMI features including 3D TV and content type bits.

Each HDMI receiver in the [ADV7626](#) incorporates an adaptive equalizer, which compensates for the high frequency losses inherent in HDMI and DVI cabling, especially at longer lengths and higher frequencies.

The [ADV7626](#) features a 768-byte internal EDID memory space, which can be used to store two independent EDIDs, one for each receiver. The memory can be partitioned to provide two 256-byte EDIDs or one 512-byte extended EDID and one 256-byte EDID. Either EDID can be replicated on any input port.

The two HDMI receivers offer advanced audio functionality. Each receiver supports multichannel I²S audio for up to eight channels. The receivers also support a six-DSD channel interface, with each channel carrying an oversampled 1-bit representation of the audio signal as delivered on SACD. The [ADV7626](#) can also receive HBR audio packet streams and output them through the HBR interface in an S/PDIF format that conforms to the IEC 60958 standard. S/PDIF is supported via the HPD back channel. The receivers also contain an audio mute controller that can detect a variety of conditions that can result in audible extraneous noise in the audio output. On detection of these conditions, the audio data can be ramped to prevent audio clicks or pops.

HDCP REPEATER FUNCTIONALITY

With the inclusion of HDCP 1.4, displays can receive encrypted video content. The HDMI interface of the [ADV7626](#) allows authentication of a video receiver, decryption of encoded data at the receiver, and renewability of that authentication during transmission, as specified by the HDCP 1.4 protocol. Repeater support is also offered by the [ADV7626](#).

DIGITAL AUDIO PORTS

The [ADV7626](#) features two independent audio input ports and two independent audio output ports. The audio input and output ports provide comprehensive muxing support for the destination of the audio (for example, to either HDMI transmitter or either audio output port) and support for the source of the audio (for example, from either HDMI receiver or from either audio input port). The extracted audio can be processed by a SHARC® processor and can be reinserted back into the HDMI output stream or output via the hardware connected to the system.

ON-SCREEN DISPLAY

A key feature of the [ADV7626](#) is the on-chip character- and icon-based OSD generator. The generated OSD can be converted to match the 4:2:2 or 4:4:4 input format in either the RGB or YCrCb color spaces. After the OSD is generated, it is overlaid at the output resolution (any video resolution up to 4k × 2k at 24 Hz/25 Hz/30 Hz) for best performance. The OSD portion of the image is optionally semitransparent using a 5-bit alpha blend between the input video and the OSD. The OSD font characters and icons can be stored in external SPI flash memory, read directly into RAM, or they can be loaded into the on-chip RAM via the SPI or I²C interface.

HDMI TRANSMITTERS

The [ADV7626](#) incorporates dual HDMI transmitters, supporting all HDTV formats up to 3 GHz (4k × 2k at 24 Hz/25 Hz/30 Hz), ARC, and all mandatory 3D TV formats. The HDMI transmitter can output any audio mode received from the HDMI receiver, including audio sample packets, HBR, or DSD.

The ARC receiver supports both single-ended and differential modes and simplifies cabling by combining an upstream audio capability in a conventional HDMI cable. Each transmitter features an on-chip MPU with an I²C master to perform HDCP operations and EDID read operations.

I²C INTERFACE

The [ADV7626](#) supports a 2-wire serial (I²C-compatible) microprocessor bus driving multiple peripherals. The [ADV7626](#) is controlled by an external I²C master device, such as a microcontroller.

OTHER FEATURES

Other features of the [ADV7626](#) include the following:

- Fully qualified software low level libraries, driver, and application
- Complete input and output audio support
- Programmable interrupt request output pins: INT1 and INT2
- Chip select and ALSB
- Low power consumption: 1.8 V digital core, 1.8 V analog, and 3.3 V digital input/output
- Temperature range: 0°C to 70°C
- 15 mm × 15 mm, Pb-free, 260-ball CSP_BGA

OUTLINE DIMENSIONS

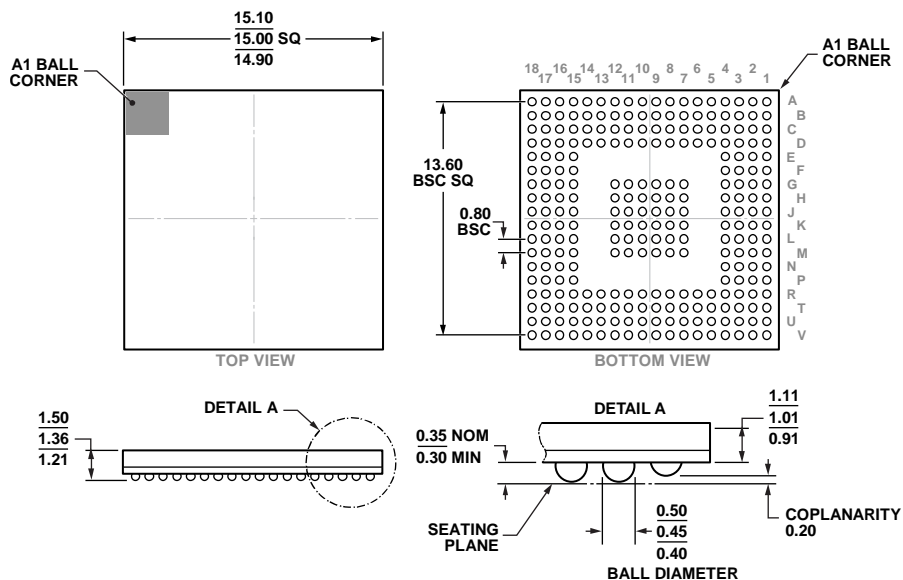

COMPLIANT TO JEDEC STANDARDS MO-275-KKAB-1.

Figure 19. 260-Ball Chip Scale Package Ball Grid Array [CSP_BGA] (BC-260-1)

Dimensions shown in millimeters

11-18-2013-B

ORDERING GUIDE

Model ^{1,2}	Temperature Range	Package Description	Package Option
ADV7626KBCZ-8	0°C to 70°C	260-Ball Chip Scale Package Ball Grid Array [CSP_BGA]	BC-260-1
ADV7626KBCZ-8-RL	0°C to 70°C	260-Ball Chip Scale Package Ball Grid Array [CSP_BGA]	BC-260-1
EVAL-ADV7625-SMZ		Evaluation Board	

¹ Z = RoHS Compliant Part.

² This part is programmed with internal HDCP keys. Customers must have HDCP adopter status (consult Digital Content Protection, LLC, for licensing requirements) to purchase any components with internal HDCP keys.

NOTES

I²C refers to a communications protocol originally developed by Philips Semiconductors (now NXP Semiconductors).

HDMI, the HDMI Logo, and High-Definition Multimedia Interface are trademarks or registered trademarks of HDMI Licensing LLC in the United States and other countries.

©2013 Analog Devices, Inc. All rights reserved. Trademarks and registered trademarks are the property of their respective owners.
D11832-0-12/13(0)



www.analog.com