

FEATURES

- Three 10-bit ADCs sampling up to 110 MHz
- 12 analog input channel mux
- NTSC/PAL/SECAM color standards support
- Adaptive digital line length tracking (ADLLT™), signal processing, and enhanced FIFO management give mini TBC functionality
- 525p/625p component progressive scan support
- 720p/1080i component HDTV support
- Digitizes RGB graphics up to 1280 × 1024 @ 60 Hz (SXGA)
- 24-bit digital input port supports data from DVI/HDMI Rx IC
- Any-to-any 3 × 3 color-space conversion matrix
- Industrial temperature range (−40°C to +85°C)
- 12-bit 4:4:4/8-bit 4:2:2 DDR pixel output interface
- Programmable interrupt request output pin

APPLICATIONS

- LCD/DLP™ rear projection HDTVs
- PDP HDTVs
- CRT HDTVs
- LCD/DLP front projectors
- LCD TV (HDTV-ready)
- HDTV STBs with PVR
- Hard disk-based video recorders
- Multiformat scan converters
- DVD recorders with progressive scan input support

GENERAL DESCRIPTION

The ADV7400A is a high quality, single chip, multiformat video decoder and graphics digitizer. This multiformat decoder supports the conversion of PAL, NTSC, and SECAM standards in the form of composite or S-video into a digital ITU-R BT.656 format. The ADV7400A also supports decoding a component RGB/YPrPb video signal into a digital YCrCb or RGB pixel output stream. The support for component video includes standards such as 525i, 625i, 525p, 625p, 720p, 1080i, 1250i, and many other HD and SMPTE standards. Graphic digitization is also supported by the ADV7400A; it is capable of digitizing RGB graphics signals from VGA to SXGA rates and converting them into a digital RGB or YCrCb pixel output stream.

The ADV7400A contains two main processing sections. The first is the standard definition processor (SDP), which processes all PAL, NTSC, and SECAM signal types. The second is the component processor (CP), which processes YPrPb and RGB component formats, including RGB graphics. For more specific descriptions of the ADV7400A features, see the Detailed Functionality and Detailed Description sections.

FUNCTIONAL BLOCK DIAGRAM

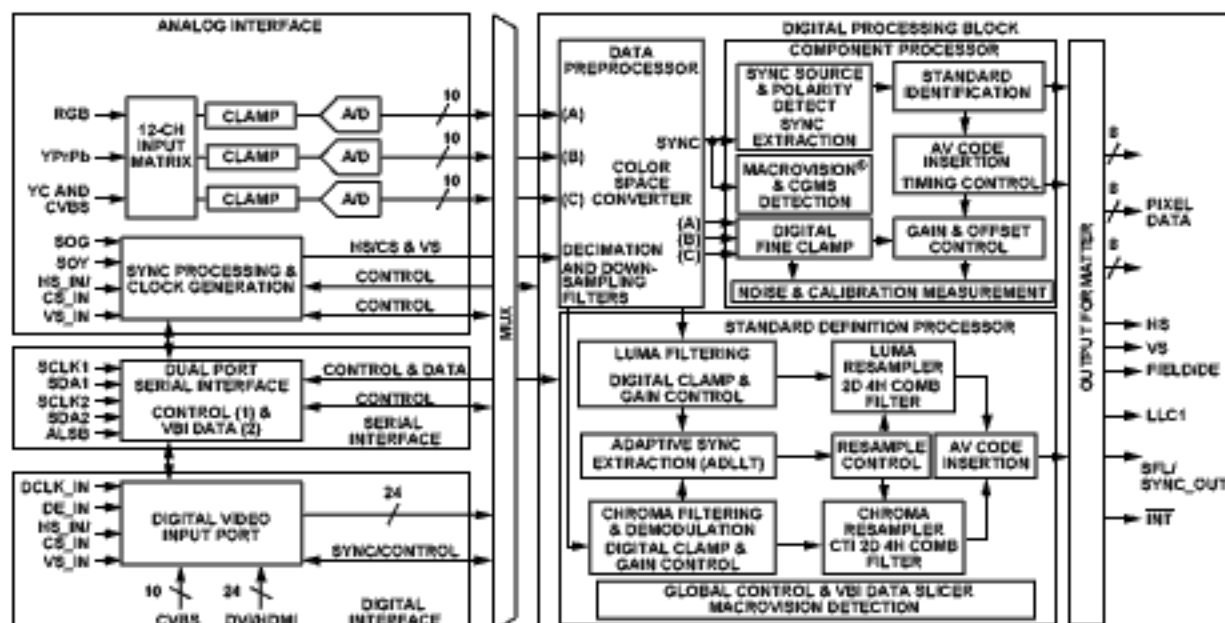

Figure 1.

Rev. A

Information furnished by Analog Devices is believed to be accurate and reliable. However, no responsibility is assumed by Analog Devices for its use, nor for any infringements of patents or other rights of third parties that may result from its use. Specifications subject to change without notice. No license is granted by implication or otherwise under any patent or patent rights of Analog Devices. Trademarks and registered trademarks are the property of their respective owners.

TABLE OF CONTENTS

Electrical Characteristics	3	Composite and S-Video Processing	10
Video Specifications	4	Component Video Processing	10
Timing Characteristics	5	RGB Graphics Processing	11
Analog Specifications	6	Digital Video Input Port	11
Thermal Specifications	6	General Features	11
Absolute Maximum Ratings	7	Detailed Description	12
ESD Caution	7	Analog Front End	12
Pin Configuration and Function Descriptions	8	Standard Definition Processor (SDP)	12
Detailed Functionality	10	Component Processor (CP)	12
Analog Front End	10	Timing Diagrams	14
SDP Pixel Data Output Modes	10	Outline Dimensions	16
CP Pixel Data Output Modes	10	Ordering Guide	16

REVISION HISTORY

3/05—Rev. 0 to Rev. A	
Changes to Features	1
Updated Outline Dimensions	16
10/04—Revision 0: Initial Version	

ELECTRICAL CHARACTERISTICS

$V_{DD} = 3.15\text{ V to }3.45\text{ V}$, $D_{VDD} = 1.65\text{ V to }2.0\text{ V}$, $D_{VDDIO} = 3.0\text{ V to }3.6\text{ V}$, $P_{VDD} = 1.65\text{ V to }2.0\text{ V}$, nominal input range = 1.6 V, operating temperature range, unless otherwise noted.

Table 1. Electrical Characteristics^{1,2}

Parameter	Symbol	Test Conditions	Min	Typ	Max	Unit
STATIC PERFORMANCE³						
Resolution (each ADC)	N				10	Bits
Integral Nonlinearity	INL	BSL at 27 MHz (at a 10-bit level)		±0.6	±2.5	LSB
Integral Nonlinearity	INL	BSL at 54 MHz (at a 10-bit level)		−0.6/+0.7		LSB
Integral Nonlinearity	INL	BSL at 74 MHz (at a 10-bit level)		−1.2/+1.5		LSB
Integral Nonlinearity	INL	BSL at 110 MHz (at an 8-bit level) ⁴		−0.9/+1.6		LSB
Differential Nonlinearity	DNL	At 27 MHz (at a 10-bit level)		−0.2/+0.25	−0.3/+0.7	LSB
Differential Nonlinearity	DNL	At 54 MHz (at a 10-bit level)		−0.2/+0.25		LSB
Differential Nonlinearity	DNL	At 74 MHz (at a 10-bit level)		±0.8		LSB
Differential Nonlinearity	DNL	At 110 MHz (at an 8-bit level) ⁴		−0.2/+1.5		LSB
DIGITAL INPUTS						
Input High Voltage	V_{IH}		2			V
Input Low Voltage	V_{IL}				0.8	V
XTAL High Voltage	V_{IH}	Pin 38	1.2			V
XTAL Low Voltage	V_{IL}	Pin 38			0.4	V
Input High Voltage	V_{IH}	HS_IN, VS_IN low trigger mode	0.7			V
Input Low Voltage	V_{IL}	HS_IN, VS_IN low trigger mode			0.4	V
Input Current	I_{IN}	Pins listed in Note 5	−60		+60	μA
		All other input pins	−10		+10	μA
Input Capacitance ⁶	C_{IN}				10	pF
DIGITAL OUTPUTS						
Output High Voltage	V_{OH}	$I_{SOURCE} = 0.4\text{ mA}$	2.4			V
Output Low Voltage	V_{OL}	$I_{SINK} = 3.2\text{ mA}$			0.4	V
High Impedance Leakage Current	I_{LEAK}	Pins listed in Note 7			60	μA
		All other output pins			10	μA
Output Capacitance ⁶	C_{OUT}				20	pF
POWER REQUIREMENTS⁶						
Digital Core Power Supply	D_{VDD}		1.65	1.8	2	V
Digital I/O Power Supply	D_{VDDIO}		3.0	3.3	3.6	V
PLL Power Supply	P_{VDD}		1.65	1.8	2	V
Analog Power Supply	A_{VDD}		3.15	3.3	3.45	V
Digital Core Supply Current	I_{DVDD}	CVBS input sampling at 54 MHz		82		mA
		Graphics RGB sampling at 110 MHz		62		mA
Digital I/O Supply Current	I_{DVDDIO}	CVBS input sampling at 54 MHz		2		mA
		Graphics RGB sampling at 110 MHz		17		mA
PLL Supply Current	I_{PVDD}	54 MHz		10.5		mA
		110 MHz		6		mA
Analog Supply Current	I_{AVDD}	CVBS input sampling at 54 MHz		85		mA
		Graphics RGB sampling at 110 MHz		218		mA
Power-Down Current	I_{PWRDN}			1.5		mA
Green Mode Power-Down	I_{PWRDNG}	Sync bypass function		12.5		mA
Power-Up Time	T_{PWRUP}			20		ms

¹ The min/max specifications are guaranteed over this range.

² Temperature range T_{MIN} to T_{MAX} : −40°C to +85°C.

³ All ADC linearity tests performed at input range of full scale are −12.5%, and at zero scale they are +12.5%.

⁴ Specifications for the ADV7400AKSTZ-110 and the ADV7400ABSTZ-110 only.

⁵ Pins: 1, 2, 3, 13, 14, 16, 19, 24, 29, 30, 31, 32, 33, 34, 35, 45, 79, 83, 84, 87, 88, 95, 96, 97, 100.

⁶ Guaranteed by characterization.

⁷ Pins: 45, 34, 33, 32, 31, 30, 29, 24, 14, 13 (P20 to P29).

VIDEO SPECIFICATIONS

$A_{VDD} = 3.15\text{ V to }3.45\text{ V}$, $D_{VDD} = 1.65\text{ V to }2.0\text{ V}$, $D_{VDDIO} = 3.0\text{ V to }3.6\text{ V}$, $P_{VDD} = 1.65\text{ V to }2.0\text{ V}$, operating temperature range, unless otherwise noted.

Table 2. Video Specifications^{1,2,3}

Parameter	Symbol	Test Conditions	Min	Typ	Max	Unit
NONLINEAR SPECIFICATIONS						
Differential Phase	DP	CVBS I/P, modulated 5 step		0.5	0.7	degree
Differential Gain	DG	CVBS I/P, modulated 5 step		0.5	0.7	%
Luma Nonlinearity	LNL	CVBS I/P, 5 step		0.5	0.7	%
NOISE SPECIFICATIONS						
SNR Unweighted		Luma ramp	54	56		dB
SNR Unweighted		Luma flat field	58	60		dB
Analog Front End Crosstalk				60		dB
LOCK TIME SPECIFICATIONS						
Horizontal Lock Range			-5		+5	%
Vertical Lock Range			40		70	Hz
F_{SC} Subcarrier Lock Range				±1.3		kHz
Color Lock in Time				60		line
Sync Depth Range			20		200	%
Color Burst Range			5		200	%
Vertical Lock Time				2		field
Horizontal Lock Time				100		line
CHROMA SPECIFICATIONS						
Hue Accuracy	HUE			1		degree
Color Saturation Accuracy	CL_AC			1		%
Color AGC Range			5		400	%
Chroma Amplitude Error				0.5		%
Chroma Phase Error				0.4		degree
Chroma Luma Intermodulation				0.2		%
LUMA SPECIFICATIONS						
Luma Brightness Accuracy		CVBS, 1 V input		1		%
Luma Contrast Accuracy		CVBS, 1 V input		1		%

¹ The min/max specifications are guaranteed over this range.

² Temperature range T_{MIN} to T_{MAX} : -40°C to +85°C.

³ Guaranteed by characterization.

TIMING CHARACTERISTICS

$A_{VDD} = 3.15\text{ V to }3.45\text{ V}$, $D_{VDD} = 1.65\text{ V to }2.0\text{ V}$, $D_{VDDIO} = 3.0\text{ V to }3.6\text{ V}$, $P_{VDD} = 1.65\text{ V to }2.0\text{ V}$, operating temperature range, unless otherwise noted.

Table 3. Timing Characteristics^{1, 2, 3}

Parameter	Symbol	Test Conditions	Min	Typ	Max	Unit
SYSTEM CLOCK AND CRYSTAL						
Crystal Nominal Frequency				27.0		MHz
Crystal Frequency Stability					±50	ppm
Horizontal Sync Input Frequency			14.8		110	kHz
LLC1 Frequency Range ⁴			12.825		110	MHz
I²C[®] PORT						
SCLK Frequency					400	kHz
SCLK Min Pulse Width High	t ₁		0.6			μs
SCLK Min Pulse Width Low	t ₂		1.3			μs
Hold Time (Start Condition)	t ₃		0.6			μs
Setup Time (Start Condition)	t ₄		0.6			μs
SDA Setup Time	t ₅		100			ns
SCLK and SDA Rise Time	t ₆				300	ns
SCLK and SDA Fall Time	t ₇				300	ns
Setup Time for Stop Condition	t ₈			0.6		μs
RESET FEATURE						
Reset Pulse Width			5			ms
CLOCK OUTPUTS						
LLC1 Mark Space Ratio	t ₉ :t ₁₀		45:55		55:45	% duty cycle
DATA and CONTROL OUTPUTS						
Data Output Transition Time (SDP)	t ₁₁	Negative clock edge to start of valid data			3.4	ns
Data Output Transition Time (SDP)	t ₁₂	End of valid data to negative clock edge			2.4	ns
Data Output Transition Time (CP)	t ₁₃	End of valid data to negative clock edge			1.1	ns
Data Output Transition Time (CP)	t ₁₄	Negative clock edge to start of valid edge			2.2	ns
Data Output Transition Time DDR (CP) ⁵	t ₁₅	Positive clock edge to end of valid data	-2.7 + T _{LLC1} /4			ns
Data Output Transition Time DDR (CP) ⁵	t ₁₆	Start of valid data to positive clock edge	-1.3 + T _{LLC1} /4			ns
Data Output Transition Time DDR (CP) ⁵	t ₁₇	Negative clock edge to end of valid data	-2.1 + T _{LLC1} /4			ns
Data Output Transition Time DDR (CP) ⁵	t ₁₈	Start of valid data to negative clock edge	-0.9 + T _{LLC1} /4			ns
DATA and CONTROL INPUTS						
Input Setup Time	t ₁₉	HS_IN, VS_IN	9			ns
		DE_IN, data inputs	2.2			ns
Input Hold Time	t ₂₀	HS_IN, VS_IN	7			ns
		DE_IN, data inputs	1			ns

¹ The min/max specifications are guaranteed over this range.

² Temperature range T_{MIN} to T_{MAX}: -40°C to +85°C.

³ Guaranteed by characterization.

⁴ Maximum LLC1 frequency is 80 MHz for the ADV7400AKSTZ-80.

⁵ DDR timing specifications depend on LLC1 output pixel clock; T_{LLC1}/4 = 9.25 ns at LLC1 = 27 MHz.

ADV7400A

ANALOG SPECIFICATIONS

$A_{VDD} = 3.1.5 \text{ V to } 3.45 \text{ V}$, $D_{VDD} = 1.65 \text{ V to } 2.0 \text{ V}$, $D_{VDDIO} = 3.0 \text{ V to } 3.6 \text{ V}$, $P_{VDD} = 1.65 \text{ V to } 2.0 \text{ V}$, operating temperature range, unless otherwise noted.

Table 4. Analog Specifications^{1, 2, 3}

Parameter	Symbol	Test Conditions	Min	Typ	Max	Unit
CLAMP CIRCUITRY						
External Clamp Capacitor				0.1		μF
Input Impedance		Clamps switched off		10		$\text{M}\Omega$
Voltage Clamp Level				1.7		V
Large Clamp Source Current		SDP only		0.75		mA
Large Clamp Sink Current		SDP only		0.75		mA
Fine Clamp Source Current		SDP only		60		μA
Fine Clamp Sink Current		SDP only		60		μA

¹ The min/max specifications are guaranteed over this range.

² Temperature range T_{MIN} to T_{MAX} : -40°C to $+85^\circ\text{C}$.

³ Guaranteed by characterization.

THERMAL SPECIFICATIONS

Table 5. Thermal Specifications

Thermal Characteristic	Symbol	Test Conditions	Typ	Unit
Junction-to-Case Thermal Resistance	θ_{JC}	4-layer PCB with solid ground plane	7	$^\circ\text{C}/\text{W}$
Junction-to-Ambient Thermal Resistance	θ_{JA}	4-layer PCB with solid ground plane (still air)	30	$^\circ\text{C}/\text{W}$

ABSOLUTE MAXIMUM RATINGS

Table 6.

Parameter	Rating
A_{VDD} to AGND	4 V
D_{VDD} to DGND	2.2 V
P_{VDD} to AGND	2.2 V
D_{VDDIO} to DGND	4 V
D_{VDDIO} to A_{VDD}	-0.3 V to +0.3V
P_{VDD} to D_{VDD}	-0.3 V to +0.3 V
$D_{VDDIO} - P_{VDD}$	-0.3 V to +2 V
$D_{VDDIO} - D_{VDD}$	-0.3 V to +2 V
$A_{VDD} - P_{VDD}$	-0.3 V to +2 V
$A_{VDD} - D_{VDD}$	-0.3 V to +2 V
Analog Inputs to AGND	AGND - 0.3 V to $A_{VDD} + 0.3 V$
Maximum Junction Temperature (T_J max)	150°C
Storage Temperature Range	-65°C to +150°C
Infrared Reflow Soldering (20 sec)	260°C

Stresses above those listed under Absolute Maximum Ratings may cause permanent damage to the device. This is a stress rating only; functional operation of the device at these or any other conditions above those indicated in the operational section of this specification is not implied. Exposure to absolute maximum rating conditions for extended periods may affect device reliability.

ESD CAUTION

ESD (electrostatic discharge) sensitive device. Electrostatic charges as high as 4000 V readily accumulate on the human body and test equipment and can discharge without detection. Although this product features proprietary ESD protection circuitry, permanent damage may occur on devices subjected to high energy electrostatic discharges. Therefore, proper ESD precautions are recommended to avoid performance degradation or loss of functionality.



ADV7400A

PIN CONFIGURATION AND FUNCTION DESCRIPTIONS

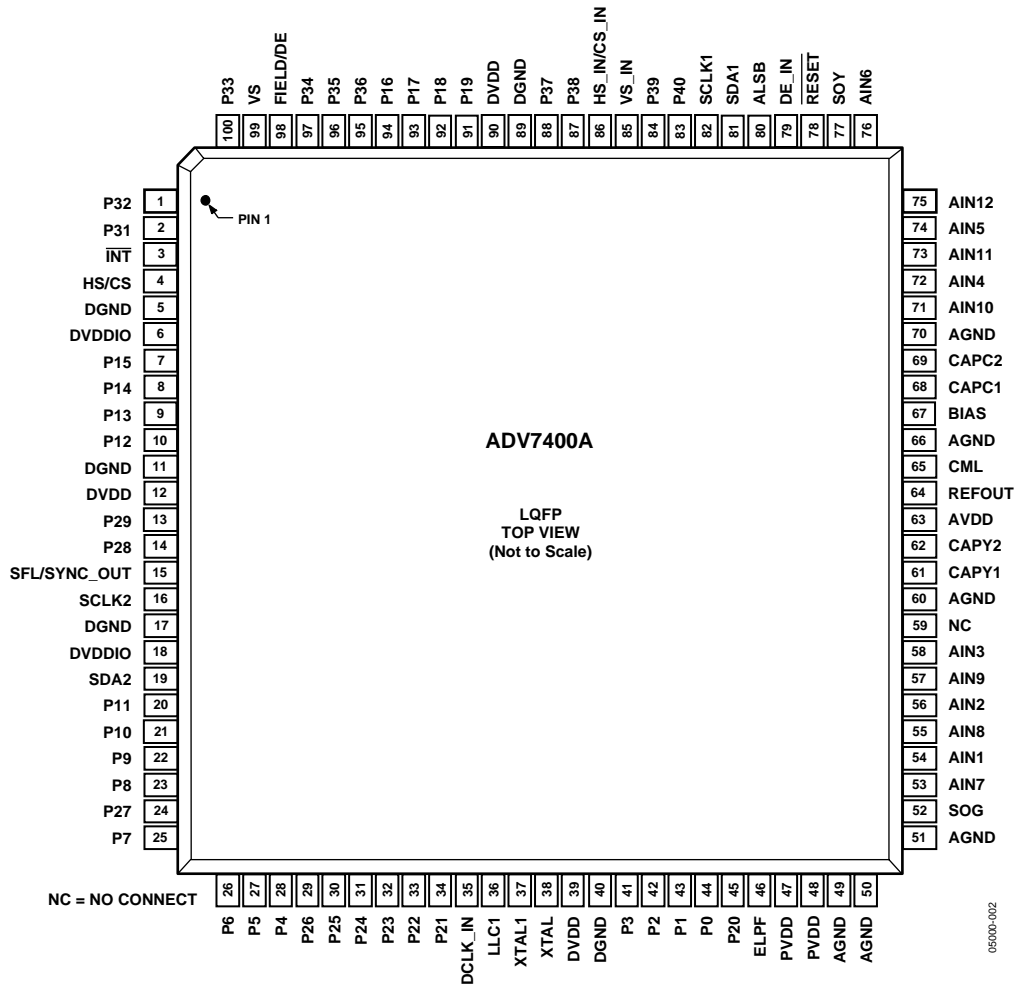

Figure 2. LQFP Pin Configuration

Table 7. Pin Function Descriptions

Pin No.	Mnemonic	Type	Description
5, 11, 17, 40, 89	DGND	G	Digital Ground.
49, 50, 51, 60, 66, 70	AGND	G	Analog Ground.
6, 18	DVDDIO	P	Digital I/O Supply Voltage (3.3 V).
12, 39, 90	DVDD	P	Digital Core Supply Voltage (1.8 V).
63	AVDD	P	Analog Supply Voltage (3.3 V).
47, 48	PVDD	P	PLL Supply Voltage (1.8 V).
54, 56, 58, 72, 74, 76, 53, 55, 57, 71, 73, 75	AIN1 to AIN12	I	Analog Video Input Channels.
42, 41, 28, 27, 26, 25, 23, 22, 10, 9, 8, 7, 94, 93, 92, 91	P2 to P9, P12 to P19	O	Video Pixel Output Port.
33, 32, 31, 30, 29, 24, 14, 13	P22 to P29	I/O	Video Pixel Input/Output Port.
44, 43, 21, 20, 45, 34, 2, 1, 100, 97, 96, 95, 88, 87, 84, 83	P0, P1, P10, P11, P20 to P21, P31 to P40	I	Video Pixel Input Port.

Pin No.	Mnemonic	Type	Description
3	INT	O	Interrupt Pin. This pin can be programmed active low or active high. When SDP/CP status bits change, this pin triggers an interrupt. The set of events which triggers an interrupt can be modified via I ² C registers.
4	HS/CS	O	Horizontal Synchronization/Composite Synchronization. HS is a horizontal synchronization output signal in SDP and CP modes. CS is a digital composite synchronization signal that can be selected while in CP mode.
99	VS	O	Vertical Synchronization. Vertical synchronization output signal in SDP and CP modes.
98	FIELD/DE	O	Field Synchronization/Data Enable. Field synchronization output signal in all interlaced video modes. This pin also can be enabled as a data enable signal in CP mode to allow direct connection to a HDMI/DVI Tx IC.
81, 19	SDA1, SDA2	I/O	I ² C Port Serial Data Input/Output Pin. SDA1 is the data line for the control port and SDA2 is the data line for the VBI readback port.
82, 16	SCLK1, SCLK2	I	I ² C Port Serial Clock Input (max clock rate of 400 kHz). SCLK1 is the clock line for the control port, and SCLK2 is the clock line for the VBI data readback port.
80	ALSB	I	This pin selects the I ² C address for the ADV7400A control and VBI readback ports. When set to a Logic 0, ALSB sets the address for a write to control port of 0x40 and the readback address for the VBI port of 0x21. When set to a Logic 1, ALSB sets the address for a write to the control port of 0x42 and the readback address for the VBI port of 0x23.
78	RESET	I	System Reset Input, Active Low. A minimum low reset pulse width of 5 ms is required to reset the ADV7400A circuitry.
36	LLC1	O	Line-locked output clock for the pixel data output by the ADV7400A (the range is 13.5 MHz to 110 MHz for the ADV7400AKSTZ-110; 13.5 MHz to 80 MHz for the ADV7400AKSTZ-80).
38	XTAL	I	Input pin for 27 MHz crystal, or it can be overdriven by an external 3.3 V 27 MHz clock oscillator source to clock the ADV7400A.
37	XTAL1	O	This pin should be connected to the 27 MHz crystal or left as a no connect if an external 3.3 V, 27 MHz clock oscillator source is used to clock the ADV7400A. In crystal mode the crystal must be a fundamental crystal.
46	ELPF	O	The recommend external loop filter must be connected to this ELPF pin.
15	SFL/SYNC_OUT	O	SFL (Subcarrier Frequency Lock). This pin contains a serial output stream that can be used to lock the subcarrier frequency when this decoder is connected to any Analog Devices digital video encoder. SYNC_OUT is the sliced sync output signal available only in CP mode.
64	REFOUT	O	Internal Voltage Reference Output.
65	CML	O	Common-Mode Level Pin for the Internal ADCs.
61, 62	CAPY1 to CAPY2	I	ADC Capacitor Network.
68, 69	CAPC1 to CAPC2	I	ADC Capacitor Network.
67	BIAS	O	External Bias Setting Pin. Connect the recommended resistor between this pin and ground.
86	HS_IN/CS_IN	I	Can be configured in CP mode to be either a digital HS input signal or a digital CS input signal, which are used to extract timing in 5-wire or 4-wire RGB mode.
85	VS_IN	I	VS Input Signal. Used in CP mode for 5-wire timing mode.
79	DE_IN	I	Data Enable Input Signal. Used in 24-bit digital input port mode, for example, 24-bit RGB data from a DVI Rx IC.
59	NC	NC	No Connect Pin. This pin can be tied to AGND or AVDD.
35	DCLK_IN	I	Clock Input Signal. Used in 24-bit digital input mode and also in digital CVBS input mode.
52	SOG	I	Sync On Green Input Pin. Used in embedded sync mode.
77	SOY	I	Sync On Luma Input Pin. Used in embedded sync mode.

DETAILED FUNCTIONALITY

ANALOG FRONT END

- Three high quality 10-bit ADCs enable true 8-bit video decoder
- 12 analog input channel mux enables multisource connection without the requirement of an external mux
- Three current and voltage clamp control loops ensure any dc offsets are removed from the video signal

SDP PIXEL DATA OUTPUT MODES

- 8-bit ITU-R BT.656 4:2:2 YCrCb with embedded time codes and/or HS, VS, and FIELD
- 16-bit YCrCb with embedded time codes and/or HS, VS, and FIELD
- 24-bit YCrCb with embedded time codes and/or HS, VS, and FIELD

CP PIXEL DATA OUTPUT MODES

- Single data rate (SDR) 16-bit 4:2:2 YCrCb for all standards
- Single data rate (SDR) 24-bit 4:4:4 YCrCb/RGB for all standards
- Double data rate (DDR) 8-bit 4:2:2 YCrCb for all standards
- Double data rate (DDR) 12-bit 4:4:4 YCrCb/RGB for all standards

COMPOSITE AND S-VIDEO PROCESSING

- Support for NTSC (J, M, 4.43), PAL (B, D, I, G, H, M, N, Nc 60) and SECAM B/D/G/K/L standards in the form of CVBS and S-video
- Super adaptive 2D 5-line comb filters for NTSC and PAL give superior chrominance and luminance separation for composite video
- Full automatic detection and autoswitching of all worldwide standards (PAL/NTSC/SECAM)
- Automatic gain control with white peak mode ensures the video is always processed without loss of the video processing range
- Adaptive digital line length tracking (ADLLT)
- Proprietary architecture for locking to weak, noisy, and unstable sources from VCRs and tuners
- IF filter block compensates for high frequency luma attenuation due to tuner SAW filter
- Chroma transient improvement (CTI)

- Luminance digital noise reduction (DNR)
- Color controls include hue, brightness, saturation, contrast, and Cr and Cb offset controls
- Certified Macrovision® copy protection detection on composite and S-video for all worldwide formats (PAL/NTSC/SECAM)
- 4× oversampling (54 MHz) for CVBS and S-video modes
- Line-locked clock output (LLC)
- Letterbox detection supported
- Free-run output mode provides stable timing when no video input is present
- Vertical blanking interval data processor
- Closed captioning (CC) and extended data service (EDS)
- Wide screen signaling (WSS)
- Copy generation management system (CGMS)
- EDTV
- Gemstar™ 1×/2× electronic program guide-compatible
- Clocked from a single 27 MHz crystal
- Subcarrier frequency lock (SFL) output for downstream video encoder
- Differential gain typically 0.5%
- Differential phase typically 0.5°

COMPONENT VIDEO PROCESSING

- Formats supported include 525i, 625i, 525p, 625p, 720p, 1080i, and many other HDTV formats
- Automatic adjustments include gain (contrast) and offset (brightness); manual adjustment controls are also supported
- Support for analog component YPrPb/RGB video formats with embedded sync or with separate HS, VS, or CS
- Any-to-any 3 × 3 color space conversion matrix supports YCrCb-to-RGB and RGB-to-YCrCb
- Standard identification (STDI) enables system level component format detection
- Certified Macrovision copy protection detection on component formats (525i, 625i, 525p, and 625p)

- Free-run output mode provides stable timing when no video input is present
- Arbitrary pixel sampling support for nonstandard video sources

RGB GRAPHICS PROCESSING

- 110 MSPS conversion rate supports RGB input resolutions up to 1280 × 1024 @ 60 Hz (SXGA); (80 MSPS conversion rate for ADV7400AKSTZ-80)
- Automatic or manual clamp and gain controls for graphics modes
- Contrast and brightness controls
- Sampling PLL clock with 500 ps p-p jitter at 110 MSPS
- 32-phase DLL allows optimum pixel clock sampling
- Automatic detection of sync source and polarity by SSPD block
- Standard identification is enabled by STDI block
- RGB can be color space converted to YCrCb and decimated to a 4:2:2 format for video centric backend IC interfacing
- Data enable (DE) output signal supplied for direct connection to HDMI/DVI Tx IC
- Arbitrary pixel sampling support for nonstandard video sources

DIGITAL VIDEO INPUT PORT

- Support for raw 10-bit CVBS data from digital tuner
- Support for 24-bit RGB input data from DVI Rx chip, output converted to YCrCb 4:2:2
- Support for 24-bit 4:4:4, 16-bit 4:2:2 525i, 625i, 525p, 625p, 1080i, 720p, VGA to SXGA @ 60 Hz input data from HDMI Rx chip, output converted to 16-bit 4:2:2 YCrCb

GENERAL FEATURES

- HS, VS, and FIELD output signals with programmable position, polarity, and width
- Programmable interrupt request output pin, $\overline{\text{INT}}$, signals SDP/CP status changes
- Supports two I²C host port interfaces (control and VBI)
- Low power consumption: 1.8 V digital core, 3.3 V analog and digital I/O, low power power-down mode, and green PC mode
- Industrial temperature range (−40°C to +85°C)
- 110 MHz and 80 MHz speed grades (ADV7400AKSTZ-110 and ADV7400AKSTZ-80)
- 100-pin 14 mm × 14 mm Pb-free LQFP package

DETAILED DESCRIPTION

ANALOG FRONT END

The ADV7400A analog front end includes three 10-bit ADCs, which digitize the analog video signal before applying it to the SDP or CP (see Table 8 for sampling rates). The analog front end uses differential channels to each ADC to ensure high performance in a mixed-signal application.

The front end also includes a 12-channel input mux, which enables multiple video signals to be applied to the ADV7400A. Current and voltage clamps are positioned in front of each ADC to ensure that the video signal remains within the range of the converter. Fine clamping of the video signals is performed downstream by digital fine clamping either in the CP or SDP.

The ADCs are configured to run in 4× oversampling mode when decoding composite and S-video inputs; 2× oversampling is performed for component 525i, 625i, 525p, and 625p sources. All other video standards are 1× oversampled. Oversampling the video signals reduces the cost and complexity of external anti-aliasing filters. This has the benefit of an increased signal-to-noise ratio (SNR).

Table 8. Maximum ADC Sampling Rates

Model	Max ADC Sampling Rate
ADV7400AKSTZ-80	80 MHz
ADV7400AKSTZ-110	110 MHz

STANDARD DEFINITION PROCESSOR (SDP)

The SDP section is capable of decoding a large selection of baseband video signals in composite and S-video formats. The video standards supported by the SDP include PAL B/D/I/G/H, PAL60, PAL M, PAL N, PAL Nc, NTSC M/J, NTSC 4.43, and SECAM B/D/G/K/L. The ADV7400A can automatically detect the video standard and process it accordingly.

The SDP has a 5-line super adaptive 2D comb filter that gives superior chrominance and luminance separation when decoding a composite video signal. This highly adaptive filter automatically adjusts its processing mode according to video standard and signal quality with no user intervention required. The SDP has an IF filter block that compensates for attenuation in the high frequency luma spectrum due to tuner SAW filter.

The SDP has specific luminance and chrominance parameter control for brightness, contrast, saturation, and hue.

The ADV7400A implements a patented adaptive-digital-line-length-tracking (ADLLT) algorithm to track varying video line lengths from sources such as a VCR. ADLLT enables the ADV7400A to track and decode poor quality video sources such as VCRs, noisy sources from tuner outputs, VCD players, and camcorders. The SDP contains a chroma transient improvement (CTI) processor. This processor increases the edge rate on chroma transitions, resulting in a sharper video image.

The SDP can process a variety of VBI data services, such as closed captioning (CC), wide screen signaling (WSS), copy generation management system (CGMS), EDTV, Gemstar 1×/2×, and extended data service (XDS). The ADV7400A SDP section has a Macrovision 7.1 detection circuit, which allows it to detect Types I, II, and III protection levels. The decoder is fully robust to all Macrovision signal inputs.

COMPONENT PROCESSOR (CP)

The CP section is capable of decoding/digitizing a wide range of component video formats in any color space. Component video standards supported by the CP are 525i, 625i, 525p, 625p, 720p, 1080i, 1250i, VGA up to SXGA @ 60 Hz, and many other standards not listed here.

The CP section of the ADV7400A also contains an automatic gain control (AGC) block. In cases where no embedded sync is present, the video gain can be set manually. The AGC block is followed by a digital clamp circuit that ensures the video signal is clamped to the correct blanking level. Automatic adjustments within the CP include gain (contrast) and offset (brightness); manual adjustment controls are also supported.

A fully programmable any-to-any 3 × 3 color space conversion matrix is placed between the analog front end and the CP section. This enables YPrPb to RGB and RGB to YCrCb conversions. Many other standards of color space may be implemented using the color space converter.

The output section of the CP is highly flexible. It can be configured in single data rate mode (SDR) with one data packet per clock cycle or in a double data rate (DDR) mode where data is presented on the rising and falling edge of the clock. In SDR mode, a 16-bit 4:2:2 or 24-bit 4:4:4 output is possible. In these modes HS, VS, and FIELD/DE (where applicable) timing reference signals are provided. In DDR mode, the ADV7400A can be configured in an 8-bit 4:2:2 YCrCb or 12-bit 4:4:4 RGB/ YCrCb pixel output interface with corresponding timing signals.

The ADV7400A is capable of supporting an external DVI/HDMI receiver. The digital interface expects 24-bit 4:4:4 or 16-bit 4:2:2 bit data (either graphics RGB or component video YCrCb), accompanied by HS, VS, DE, and a fully synchronous clock signal. The data is processed in the CP and output as 16-bit 4:2:2 YCrCb data.

The CP section contains circuitry to enable the detection of Macrovision encoded YPrPb signals for 525i, 625i, 525p, and 625p. It is designed to be fully robust when decoding these types of signals.

VBI extraction of CGMS data is performed by the CP section of the ADV7400A for interlaced, progressive, and high definition scanning rates. The data extracted can be read back over the I²C interface. For more detailed product information about the ADV7400A, contact your local ADI sales office or email video.products@analog.com.

TIMING DIAGRAMS

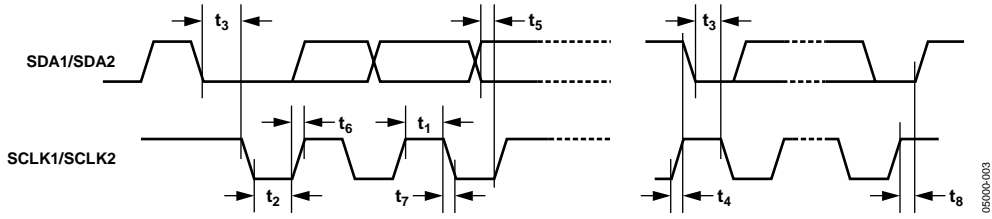

Figure 3. I²C Timing

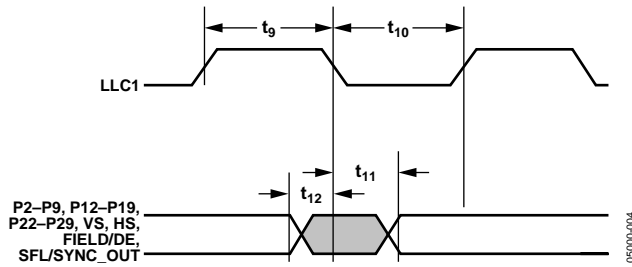

Figure 4. Pixel Port and Control Output SDR Timing (SD Core)

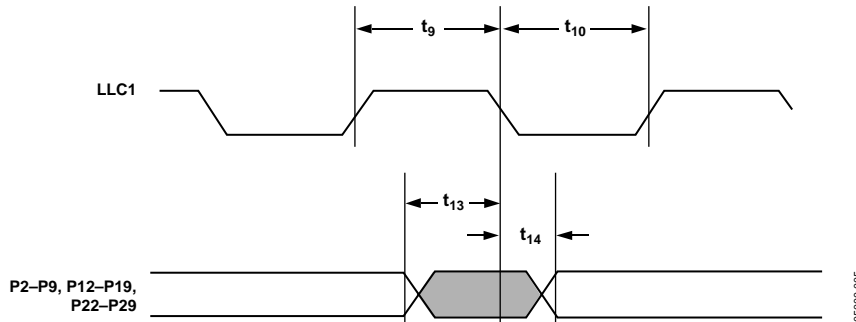

Figure 5. Pixel Port SDR Timing (CP Core)

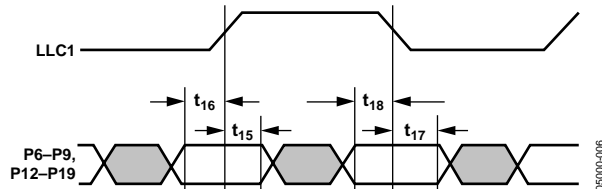

Figure 6. Pixel Port DDR Timing (CP Core)

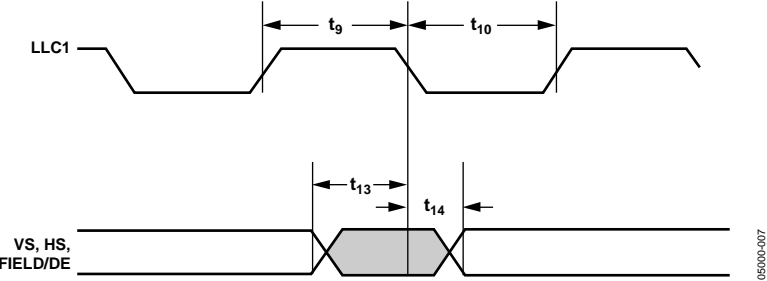

Figure 7. Control Output SDR/DDR Timing (CP Core)

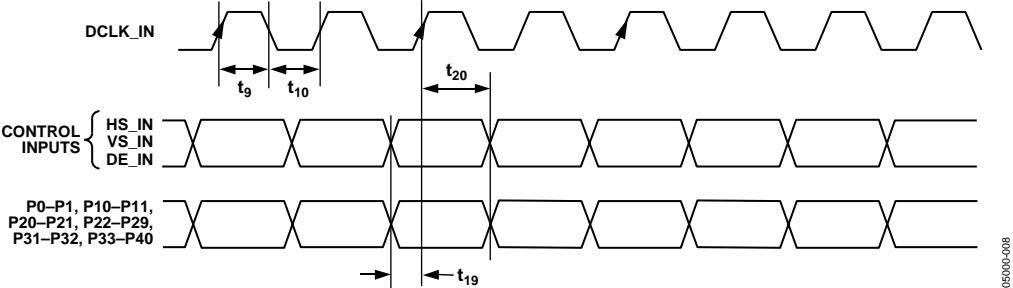
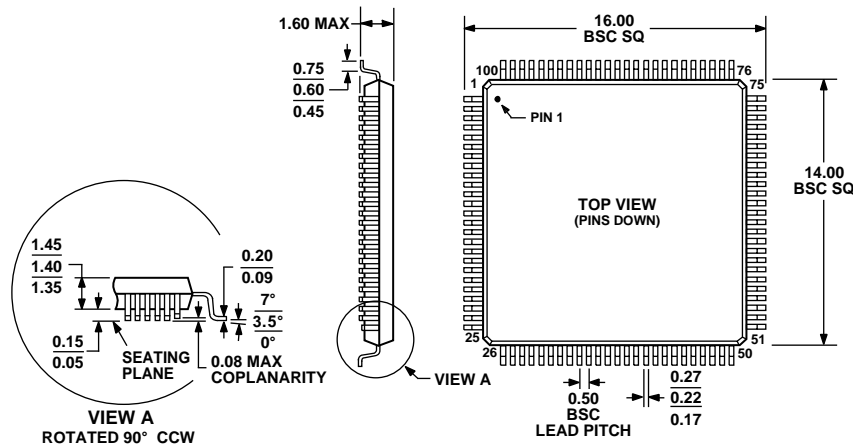

Figure 8. Digital Input Port and Control Input Timing

OUTLINE DIMENSIONS



COMPLIANT TO JEDEC STANDARDS MS-026-BED

Figure 9. 100-Lead Low Profile Quad Flat Package [LQFP]
(ST-100)
Dimensions shown in millimeters

ORDERING GUIDE

Model	Temperature Range	Package Description	Package Option
ADV7400AKSTZ-110 ¹	-25°C to +70°C	100-Lead LQFP	ST-100
ADV7400AKSTZ-80 ¹	-25°C to +70°C	100-Lead LQFP	ST-100
ADV7400ABSTZ-110 ¹	-40°C to +85°C	100-Lead LQFP	ST-100
EVAL-ADV7400AEBM		Evaluation Board	

¹ Z = Pb-free part. The ADV7400A is a Pb-free environmentally friendly product. It is manufactured using the most up-to-date materials and processes. The coating on the leads of each device is 100% pure Sn electroplate. The device is suitable for Pb-free applications, and is able to withstand surface-mount soldering at up to 255°C (±5°C). In addition, it is backward compatible with conventional SnPb soldering processes. This means that the electroplated Sn coating can be soldered with SnPb solder pastes at conventional reflow temperatures of 220°C to 235°C.

Purchase of licensed I²C components of Analog Devices or one of its sublicensed Associated Companies conveys a license for the purchaser under the Philips I²C Patent Rights to use these components in an I²C system, provided that the system conforms to the I²C Standard Specification as defined by Philips.