

FEATURES

- ±0.5°C (typical) threshold accuracy
- Factory-set trip points from
 - 45°C to +15°C in 10°C increments
 - +35°C to +115°C in 10°C increments
- No external components required
- Maximum temperature of 125°C
- Open-drain output (ADT6501/ADT6503)
- Push-pull output (ADT6502/ADT6504)
- Pin-selectable hysteresis of 2°C and 10°C
- Supply current of 30 µA (typical)
- Space-saving, 5-lead SOT-23 package

APPLICATIONS

- Medical equipment
- Automotive
- Cell phones
- Hard disk drives
- Personal computers
- Electronic test equipment
- Domestic appliances
- Process control

GENERAL DESCRIPTION

The ADT6501/ADT6502/ADT6503/ADT6504 are trip point temperature switches available in a 5-lead SOT-23 package. Each part contains an internal band gap temperature sensor for local temperature sensing. When the temperature crosses the trip point setting, the logic output is activated. The ADT6501/ADT6503 logic output is active low and open-drain. The ADT6502/ADT6504 logic output is active high and push-pull. The temperature is digitized to a resolution of 0.125°C (11-bit). The factory trip point settings are 10°C apart starting from –45°C to +15°C for the cold threshold models and from +35°C to +115°C for the hot threshold models.

These devices require no external components and typically consume 30 µA supply current. Hysteresis is pin-selectable at 2°C and 10°C. The temperature switch is specified to operate over the supply range of 2.7 V to 5.5 V.

The ADT6501 and ADT6502 are used for monitoring temperatures from +35°C to +115°C only. Therefore, the logic output pin becomes active when the temperature goes higher than the selected trip point temperature.

FUNCTIONAL BLOCK DIAGRAM

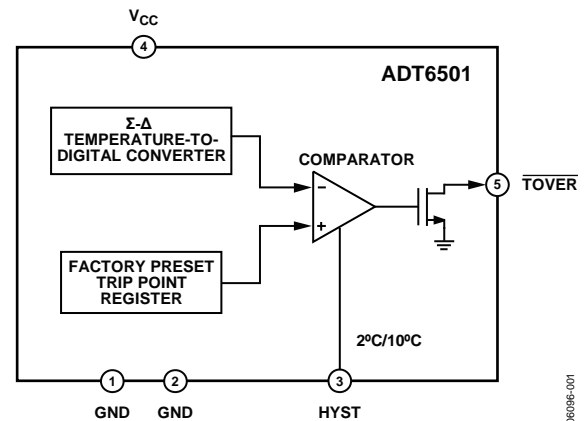

Figure 1.

The ADT6503 and ADT6504 are used for monitoring temperatures from –45°C to +15°C only. Therefore, the logic output pin becomes active when the temperature goes lower than the selected trip point temperature.

PRODUCT HIGHLIGHTS

1. Σ-Δ based temperature measurement gives high accuracy and noise immunity.
2. Wide operating temperature range from –55°C to +125°C.
3. ±0.5°C typical accuracy from –45°C to +115°C.
4. Factory threshold settings from –45°C to +115°C in 10°C increments.
5. Supply voltage is 2.7 V to 5.5 V.
6. Supply current of 30 µA.
7. Space-saving, 5-lead SOT-23 package.
8. Pin-selectable temperature hysteresis of 2°C or 10°C.
9. Temperature resolution of 0.125°C.

Rev. B

[Document Feedback](#)

Information furnished by Analog Devices is believed to be accurate and reliable. However, no responsibility is assumed by Analog Devices for its use, nor for any infringements of patents or other rights of third parties that may result from its use. Specifications subject to change without notice. No license is granted by implication or otherwise under any patent or patent rights of Analog Devices. Trademarks and registered trademarks are the property of their respective owners.

TABLE OF CONTENTS

Features	1	Converter Details	8
Applications.....	1	Factory-Programmed Threshold Range	8
Functional Block Diagram	1	Hysteresis Input	8
General Description	1	Temperature Conversion.....	8
Product Highlights	1	Application Information.....	10
Revision History	2	Thermal Response Time	10
Specifications.....	3	Self-Heating Effects.....	10
Absolute Maximum Ratings.....	4	Supply Decoupling	10
ESD Caution.....	4	Temperature Monitoring.....	10
Pin Configurations and Function Descriptions	5	Typical Application Circuits	11
Typical Performance Characteristics	6	Outline Dimensions	13
Theory of Operation	8	Ordering Guide	13
Circuit Information.....	8		

REVISION HISTORY

9/12—Rev. A to Rev. B

Change to Supply Current Parameter, Table 1.....	3
Updated Outline Dimensions	13

1/08—Rev. 0 to Rev. A

Added ADT6503 and ADT6504.....	Universal
Changes to Features.....	1

Changes to Product Highlights	1
Changes to Table 1.....	3
Changes to Typical Performance Characteristics	6
Changes to Ordering Guide	13

9/07—Revision 0: Initial Version

SPECIFICATIONS

$T_A = -55^\circ\text{C}$ to $+125^\circ\text{C}$, $V_{CC} = 2.7\text{ V}$ to 5.5 V , open-drain $R_{PULL-UP} = 10\text{ k}\Omega$, unless otherwise noted.

Table 1.

Parameter	Min	Typ	Max	Unit	Test Conditions/Comments
TEMPERATURE SENSOR AND ADC					
Threshold Accuracy		± 0.5	± 6	$^\circ\text{C}$	$T_A = -45^\circ\text{C}$ to -25°C
		± 0.5	± 4	$^\circ\text{C}$	$T_A = -15^\circ\text{C}$ to $+15^\circ\text{C}$
		± 0.5	± 4	$^\circ\text{C}$	$T_A = 35^\circ\text{C}$ to 65°C
		± 0.5	± 6	$^\circ\text{C}$	$T_A = 75^\circ\text{C}$ to 115°C
ADC Resolution		11		Bits	
Temperature Conversion Time		30		ms	Time necessary to complete a conversion
Update Rate		600		ms	Conversion started every 600 ms
Temperature Threshold Hysteresis		2		$^\circ\text{C}$	HYST pin = 0 V
		10		$^\circ\text{C}$	HYST pin = V_{CC}
DIGITAL INPUT (HYST)					
Input Low Voltage, V_{IL}			$0.2 \times V_{CC}$	V	
Input High Voltage, V_{IH}	$0.8 \times V_{CC}$			V	
DIGITAL OUTPUT (OPEN-DRAIN)					
Output High Current, I_{OH}		10		nA	Leakage current, $V_{CC} = 2.7\text{ V}$ and $V_{OH} = 5.5\text{ V}$
Output Low Voltage, V_{OL}			0.3	V	$I_{OL} = 1.2\text{ mA}$, $V_{CC} = 2.7\text{ V}$
			0.4	V	$I_{OL} = 3.2\text{ mA}$, $V_{CC} = 4.5\text{ V}$
Output Capacitance, C_{OUT}^1			10	pF	$R_{PULL-UP} = 10\text{ k}\Omega$
DIGITAL OUTPUT (PUSH-PULL)					
Output Low Voltage, V_{OL}			0.3	V	$I_{OL} = 1.2\text{ mA}$, $V_{CC} = 2.7\text{ V}$
			0.4	V	$I_{OL} = 3.2\text{ mA}$, $V_{CC} = 4.5\text{ V}$
Output High Voltage, V_{OH}	$0.8 \times V_{CC}$			V	$I_{SOURCE} = 500\text{ }\mu\text{A}$, $V_{CC} = 2.7\text{ V}$
	$V_{CC} - 1.5$			V	$I_{SOURCE} = 800\text{ }\mu\text{A}$, $V_{CC} = 4.5\text{ V}$
Output Capacitance, C_{OUT}^1			10	pF	
POWER REQUIREMENTS					
Supply Voltage	2.7		5.5	V	
Supply Current		30	55	μA	

¹ Guaranteed by design and characterization.

ABSOLUTE MAXIMUM RATINGS

Table 2.

Parameter	Rating
V _{CC} to GND	-0.3 V to +7 V
HYST Input Voltage to GND	-0.3 V to V _{CC} + 0.3 V
Open-Drain Output Voltage to GND	-0.3 V to +7 V
Push-Pull Output Voltage to GND	-0.3 V to V _{CC} + 0.3 V
Input Current on All Pins	20 mA
Output Current on All Pins	20 mA
Operating Temperature Range	-55°C to +125°C
Storage Temperature Range	-65°C to +160°C
Maximum Junction Temperature, T _{JMAX}	150.7°C
5-Lead SOT-23 (RJ-5)	
Power Dissipation ¹	$W_{MAX} = (T_{JMAX} - T_A^2)/\theta_{JA}$
Thermal Impedance ³	
θ _{JA} , Junction-to-Ambient (Still Air)	240°C/W
IR Reflow Soldering (RoHS Compliant Package)	
Peak Temperature	260°C (+0°C)
Time at Peak Temperature	20 sec to 40 sec
Ramp-Up Rate	3°C/sec maximum
Ramp-Down Rate	-6°C/sec maximum
Time 25°C to Peak Temperature	8 minute maximum

¹ Values relate to package being used on a standard 2-layer PCB. This gives a worst case θ_{JA}. Refer to Figure 2 for a plot of maximum power dissipation vs. ambient temperature (T_A).

² T_A = ambient temperature.

³ Junction-to-case resistance is applicable to components featuring a preferential flow direction, for example, components mounted on a heat sink. Junction-to-ambient resistance is more useful for air-cooled, PCB-mounted components.

Stresses above those listed under Absolute Maximum Ratings may cause permanent damage to the device. This is a stress rating only; functional operation of the device at these or any other conditions above those indicated in the operational section of this specification is not implied. Exposure to absolute maximum rating conditions for extended periods may affect device reliability.

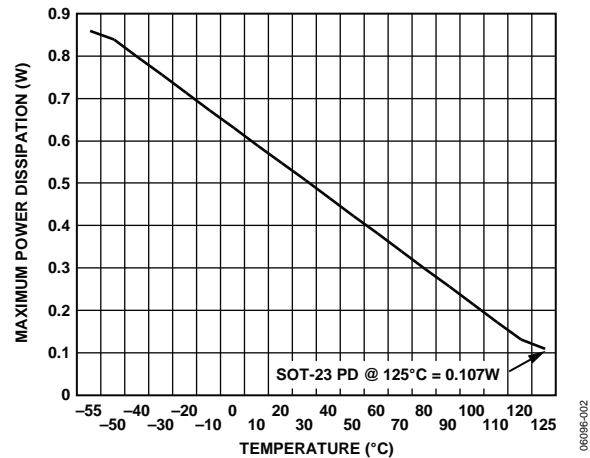

Figure 2. SOT-23 Maximum Power Dissipation vs. Temperature

ESD CAUTION



ESD (electrostatic discharge) sensitive device. Charged devices and circuit boards can discharge without detection. Although this product features patented or proprietary protection circuitry, damage may occur on devices subjected to high energy ESD. Therefore, proper ESD precautions should be taken to avoid performance degradation or loss of functionality.

PIN CONFIGURATIONS AND FUNCTION DESCRIPTIONS

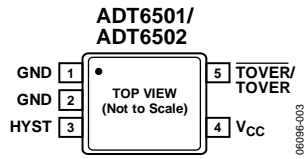

Figure 3. ADT6501/ADT6502 Pin Configuration

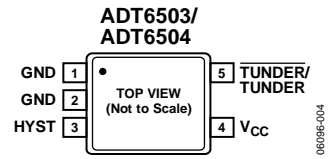

Figure 4. ADT6503/ADT6504 Pin Configuration

Table 3. Pin Function Descriptions

Pin Number				Mnemonic	Description
ADT6501	ADT6502	ADT6503	ADT6504		
1, 2	1, 2	1, 2	1, 2	GND	Ground.
3	3	3	3	HYST	Hysteresis Input. Connects HYST to GND for 2°C hysteresis or connects to V _{CC} for 10°C hysteresis.
4	4	4	4	V _{CC}	Supply Input (2.7 V to 5.5 V).
5	—	—	—	TOVER	Open-Drain, Active Low Output. TOVER goes low when the temperature of the part exceeds the factory-programmed threshold; must use a pull-up resistor.
—	5	—	—	TOVER	Push-Pull, Active High Output. TOVER goes high when the temperature of the part exceeds the factory-programmed threshold.
—	—	5	—	TUNDER	Open-Drain, Active Low Output. TUNDER goes low when the temperature of the part exceeds the factory-programmed threshold; must use a pull-up resistor.
—	—	—	5	TUNDER	Push-Pull, Active High Output. TUNDER goes high when the temperature of the part exceeds the factory-programmed threshold.

TYPICAL PERFORMANCE CHARACTERISTICS

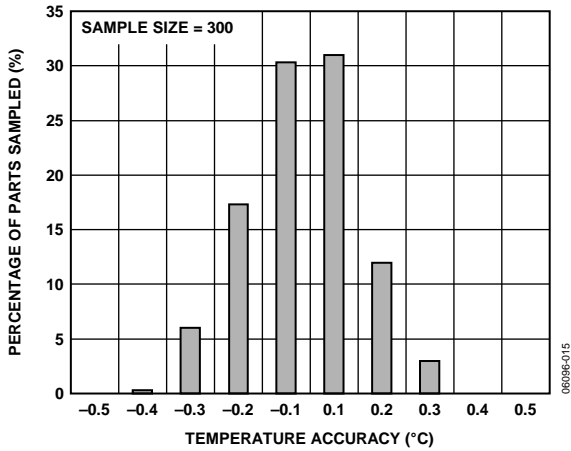

Figure 5. Trip Threshold Accuracy

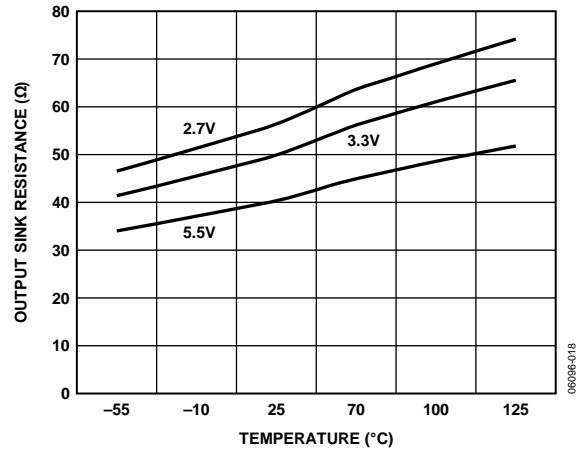

Figure 8. Output Sink Resistance vs. Temperature

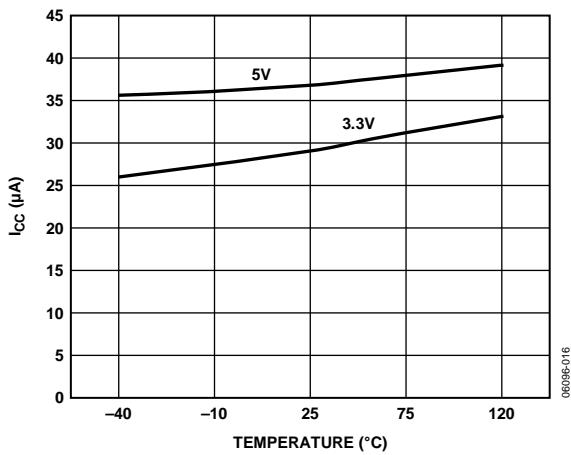

Figure 6. Operating Supply Current vs. Temperature

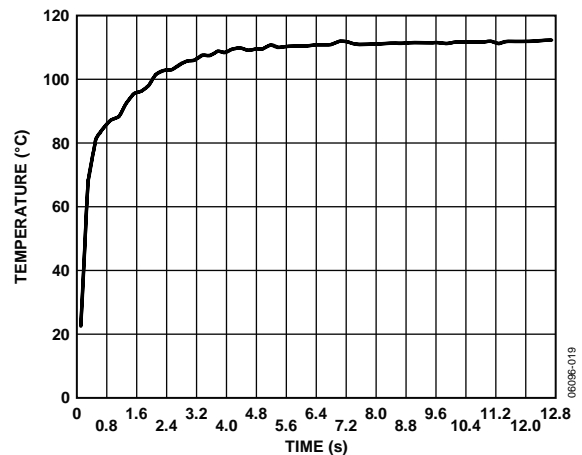

Figure 9. Thermal Step Response in Perfluorinated Fluid

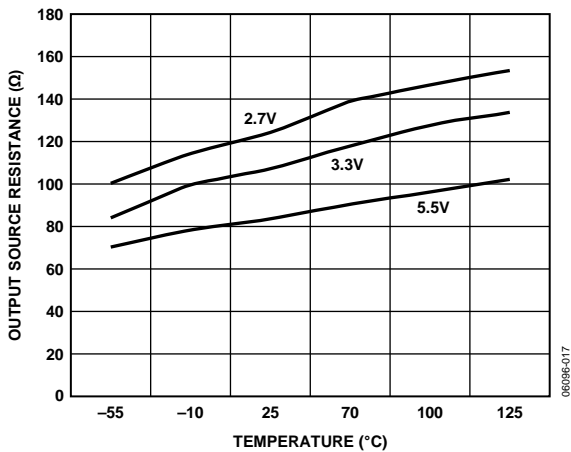

Figure 7. ADT6502/ADT6504 Output Source Resistance vs. Temperature

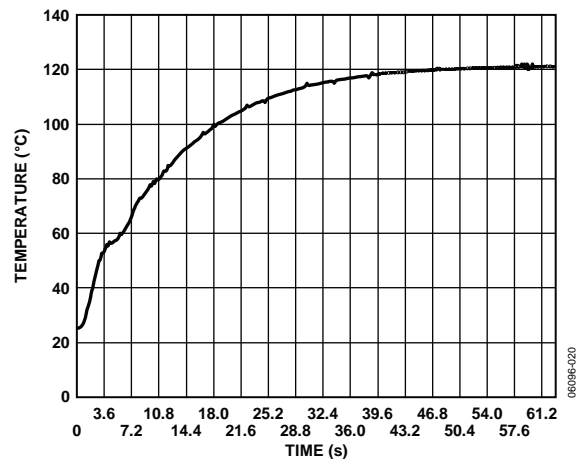

Figure 10. Thermal Step Response in Still Air

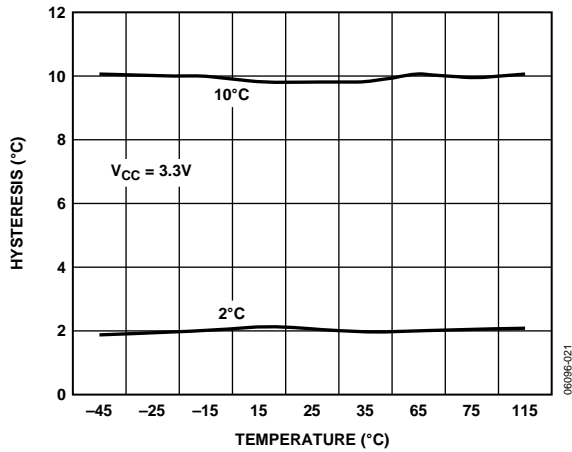

Figure 11. Hysteresis vs. Trip Temperature

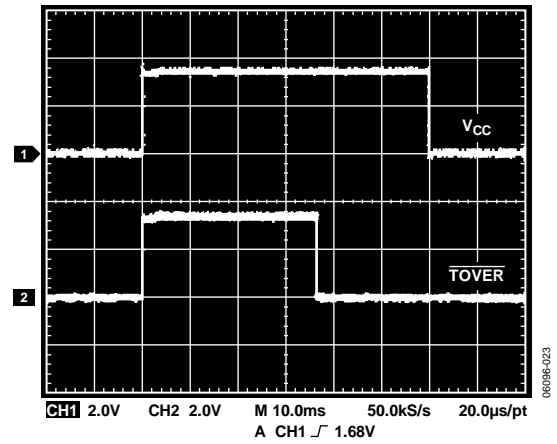

Figure 13. ADT6501 Start-Up Delay

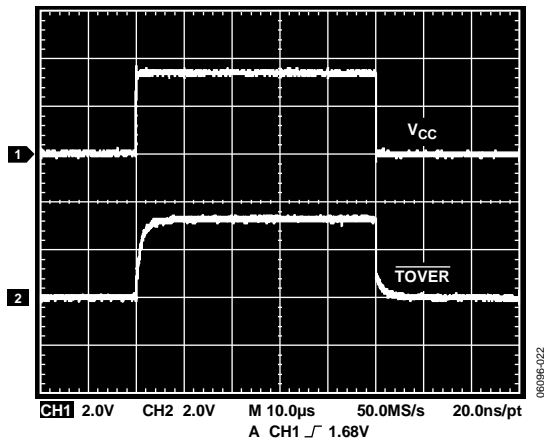

Figure 12. ADT6501 Start-Up and Power-Down

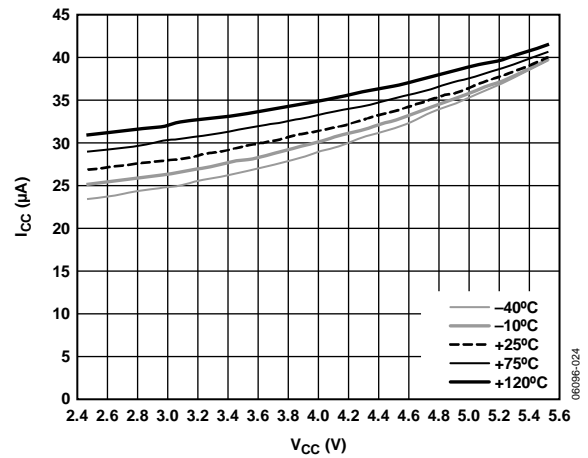

Figure 14. Operating Supply Current vs. Voltage Over Temperature

THEORY OF OPERATION

CIRCUIT INFORMATION

The ADT6501/ADT6502/ADT6503/ADT6504 are 11-bit digital temperature sensors with a 12th bit acting as the sign bit. An on-board temperature sensor generates a voltage precisely proportional to absolute temperature, which is compared to an internal voltage reference and input to a precision digital modulator. The 12-bit output from the modulator is input into a digital comparator where it is compared with a factory-set trip level. The output trip pin is activated if the temperature measured is greater than, in the case of the ADT6501/ADT6502, or less than, in the case of the ADT6503/ADT6504, the factory-set trip level. Overall accuracy for the ADT650x family is $\pm 6^{\circ}\text{C}$ (maximum) from -45°C to $+115^{\circ}\text{C}$.

The on-board temperature sensor has excellent accuracy and linearity over the entire rated temperature range without needing correction or calibration by the user. The ADT6501/ADT6503 have active low, open-drain output structures that can sink current. The ADT6502/ADT6504 have active high, push-pull output structures that can sink and source current. On power-up, the output becomes active when the first conversion is completed, which typically takes 30 ms.

The sensor output is digitized by a first-order, Σ - Δ modulator, also known as the charge balance type analog-to-digital converter (ADC). This type of converter utilizes time domain oversampling and a high accuracy comparator to deliver 11 bits of effective accuracy in an extremely compact circuit.

CONVERTER DETAILS

The Σ - Δ modulator consists of an input sampler, a summing network, an integrator, a comparator, and a 1-bit digital-to-analog converter (DAC). Similar to the voltage-to-frequency converter, this architecture creates a negative feedback loop and minimizes the integrator output by changing the duty cycle of the comparator output in response to input voltage changes. The comparator samples the output of the integrator at a much higher rate than the input sampling frequency; this is called oversampling. Oversampling spreads the quantization noise over a much wider band than that of the input signal, improving overall noise performance and increasing accuracy.

FACTORY-PROGRAMMED THRESHOLD RANGE

The ADT6501/ADT6502/ADT6503/ADT6504 are available with factory-set threshold levels ranging from -45°C to $+115^{\circ}\text{C}$ in 10°C temperature steps. The ADT6501/ADT6503 outputs are intended to interface to reset inputs of microprocessors. The ADT6502/ADT6504 are intended for driving circuits of applications such as fan control circuits. Table 4 lists the available temperature threshold ranges.

Table 4. Factory-Set Temperature Threshold Ranges

Device	Threshold (T_{TH}) Range
ADT6501	$+35^{\circ}\text{C} < T_{\text{TH}} < +115^{\circ}\text{C}$
ADT6502	$+35^{\circ}\text{C} < T_{\text{TH}} < +115^{\circ}\text{C}$
ADT6503	$-45^{\circ}\text{C} < T_{\text{TH}} < +15^{\circ}\text{C}$
ADT6504	$-45^{\circ}\text{C} < T_{\text{TH}} < +15^{\circ}\text{C}$

HYSTERESIS INPUT

The HYST pin is used to select a temperature hysteresis of 2°C or 10°C . The digital comparator ensures excellent accuracy for the hysteresis value. If the HYST pin is connected to V_{CC} , a hysteresis of 10°C is selected. If the HYST pin is connected to GND, a hysteresis of 2°C is selected. The HYST pin should not be left floating. Hysteresis prevents oscillation on the output pin when the temperature is approaching the trip point and after the output pin is activated. For example, if the temperature trip is 45°C and the hysteresis selected is 10°C , the temperature would have to go as low as 35°C before the output deactivates.

TEMPERATURE CONVERSION

The conversion clock for the part is generated internally. No external clock is required. The internal clock oscillator runs an automatic conversion sequence. During this automatic conversion sequence, a conversion is initiated every 600 ms. At this time, the part powers up its analog circuitry and performs a temperature conversion.

This temperature conversion typically takes 30 ms, after which the analog circuitry of the part automatically shuts down. The analog circuitry powers up again 570 ms later, when the 600 ms timer times out and the next conversion begins. The result of the most recent temperature conversion is compared with the factory-set trip point value. If the temperature measured is greater than the trip point value, the output is activated. The output is deactivated once the temperature crosses back over the trip point threshold plus whatever temperature hysteresis is selected. Figure 15 to Figure 18 show the transfer function for the output trip pin of each generic model.

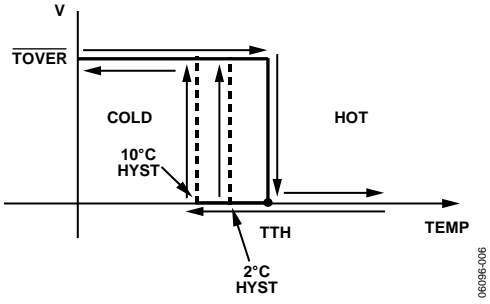

Figure 15. ADT6501 TOVER Transfer Function

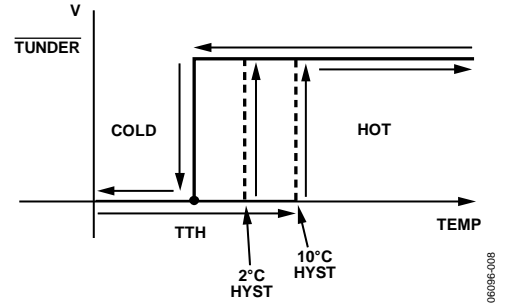

Figure 17. ADT6503 TUNDER Transfer Function

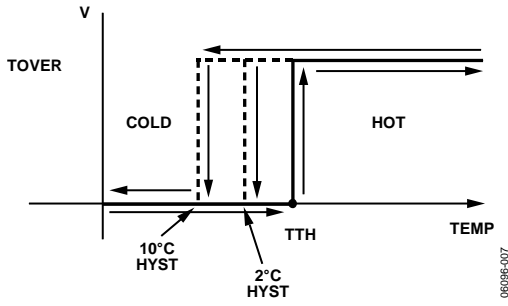

Figure 16. ADT6502 TOVER Transfer Function

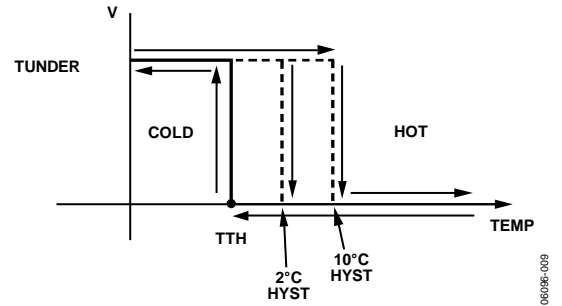

Figure 18. ADT6504 TUNDER Transfer Function

APPLICATION INFORMATION

THERMAL RESPONSE TIME

The time required for a temperature sensor to settle to a specified accuracy is a function of the sensor's thermal mass and the thermal conductivity between the sensor and the object being sensed. Thermal mass is often considered equivalent to capacitance. Thermal conductivity is commonly specified using the symbol Q and can be thought of as thermal resistance. It is commonly specified in units of degrees per watt of power transferred across the thermal joint. Thus, the time required for the ADT650x to settle to the desired accuracy is dependent on the characteristics of the SOT-23 package, the thermal contact established in that particular application, and the equivalent power of the heat source. In most applications, the settling time is best determined empirically.

SELF-HEATING EFFECTS

The temperature measurement accuracy of the ADT6501/ADT6502/ADT6503/ADT6504 can be degraded in some applications due to self-heating. Errors can be introduced from the quiescent dissipation and power dissipated when converting. The magnitude of these temperature errors depends on the thermal conductivity of the ADT650x package, the mounting technique, and the effects of airflow. At 25°C, static dissipation in the ADT650x is typically 99 μ W operating at 3.3 V. In the 5-lead SOT-23 package mounted in free air, this accounts for a temperature increase due to self-heating of

$$\Delta T = P_{DISS} \times \theta_{JA} = 99 \mu\text{W} \times 240^\circ\text{C/W} = 0.024^\circ\text{C}$$

It is recommended that current dissipated through the device be kept to a minimum because it has a proportional effect on the temperature error.

SUPPLY DECOUPLING

The ADT6501/ADT6502/ADT6503/ADT6504 should be decoupled with a 0.1 μ F ceramic capacitor between V_{CC} and GND. This is particularly important when the ADT650x are mounted remotely from the power supply. Precision analog products such as the ADT650x require well filtered power sources. Because the ADT650x operate from a single supply, it may seem convenient to tap into the digital logic power supply.

Unfortunately, the logic supply is often a switch-mode design, which generates noise in the 20 kHz to 1 MHz range. In addition, fast logic gates can generate glitches that are hundreds of mV in amplitude due to wiring resistance and inductance.

If possible, the ADT650x should be powered directly from the system power supply. This arrangement, shown in Figure 19, isolates the analog section from the logic switching transients. Even if a separate power supply trace is not available, generous supply bypassing reduces supply line induced errors. Local supply bypassing consisting of a 0.1 μ F ceramic capacitor is advisable to achieve the temperature accuracy specifications. This decoupling capacitor must be placed as close as possible to the ADT650x V_{CC} pin.

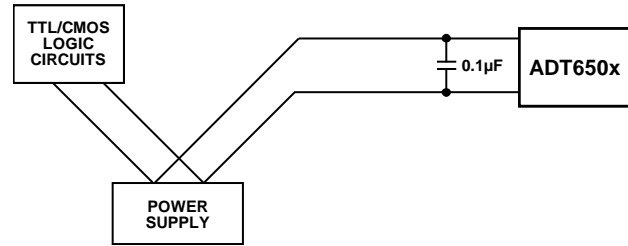

Figure 19. Separate Traces Used to Reduce Power Supply Noise

TEMPERATURE MONITORING

The ADT6501/ADT6502/ADT6503/ADT6504 are ideal for monitoring the thermal environment within electronic equipment. For example, the surface-mount package accurately reflects the exact thermal conditions that affect nearby integrated circuits.

The ADT650x measure and convert the temperature at the surface of its own semiconductor chip. When the ADT650x are used to measure the temperature of a nearby heat source, the thermal impedance between the heat source and the ADT650x must be as low as possible.

As much as 60% of the heat transferred from the heat source to the thermal sensor on the ADT650x die is discharged via the copper tracks, package pins, and bond pads. Of the pins on the ADT650x, the GND pins transfer most of the heat. Therefore, to monitor the temperature of a heat source, it is recommended that the thermal resistance between the ADT650x GND pins and the GND of the heat source be reduced as much as possible.

For example, the unique properties of the ADT650x can be used to monitor a high power dissipation microprocessor. The ADT650x device in its SOT-23 package is mounted directly beneath the microprocessor's pin grid array (PGA) package. The ADT650x requires no external characterization.

TYPICAL APPLICATION CIRCUITS

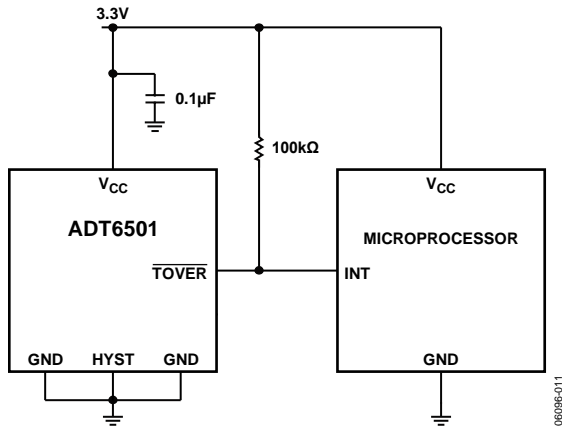

Figure 20. Microprocessor Alarm

06096-011

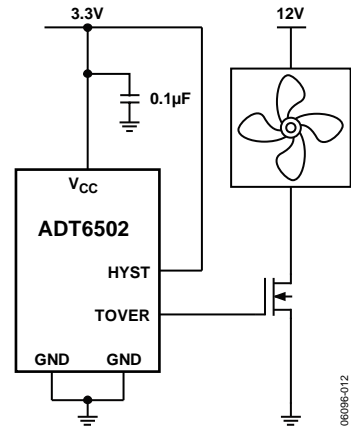

Figure 21. Overtemperature Fan Control

06096-012

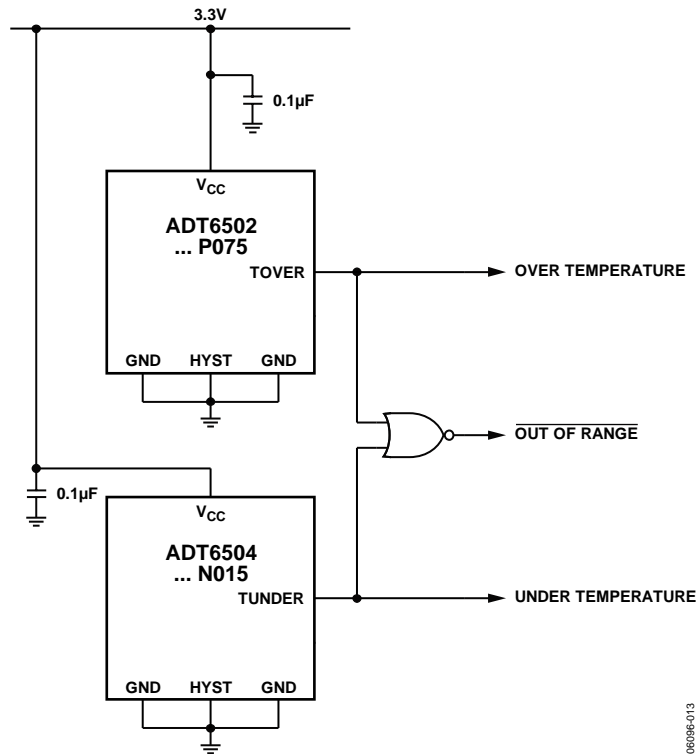
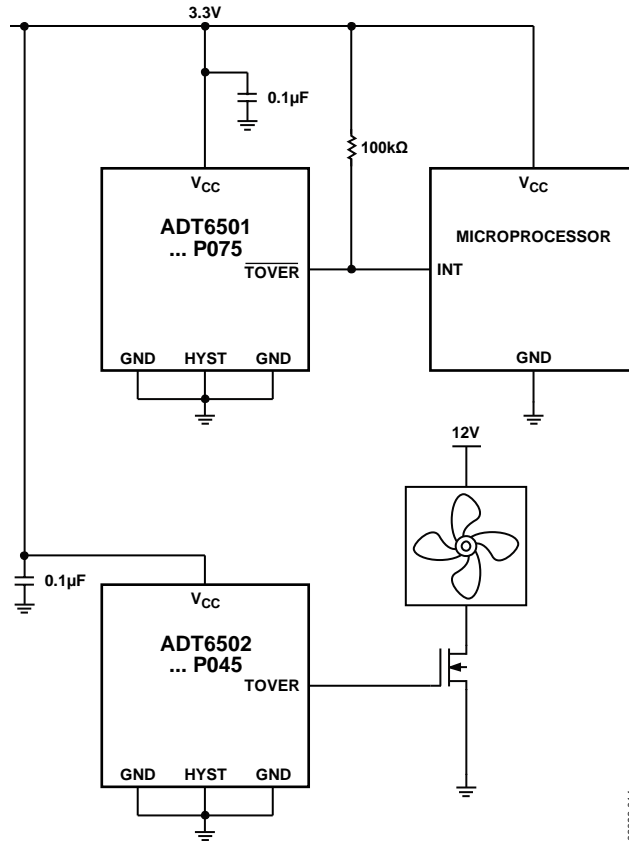

Figure 22. Temperature Window Alarms

06096-013



0609B-014

Figure 23. Fail-Safe Temperature Monitor

OUTLINE DIMENSIONS

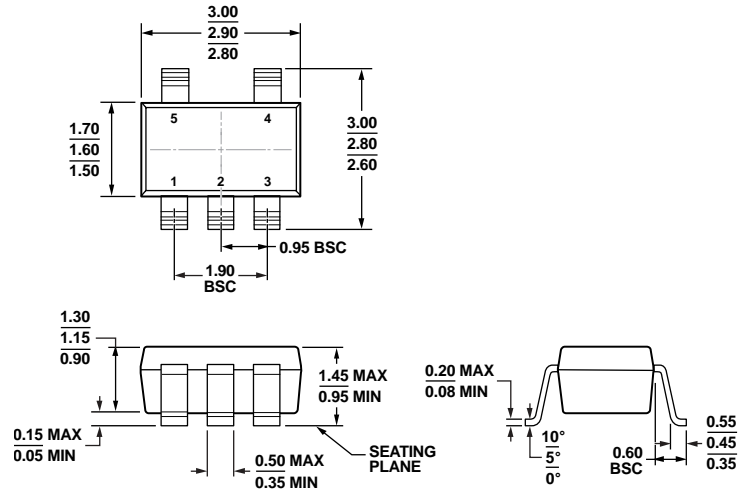

COMPLIANT TO JEDEC STANDARDS MO-178-AA

Figure 24. 5-Lead Small Outline Transistor Package [SOT-23]

(RJ-5)

Dimensions shown in millimeters

11-01-2010-A

ORDERING GUIDE

Model ¹	Threshold Temperature	Accuracy @ Threshold Temperature	Temperature Range	Package Description	Package Option	Ordering Quantity	Branding
ADT6501SRJZP035RL7	35°C	±4°C	-55°C to +125°C	5-Lead SOT-23	RJ-5	3,000	T1U
ADT6501SRJZP045RL7	45°C	±4°C	-55°C to +125°C	5-Lead SOT-23	RJ-5	3,000	T1V
ADT6501SRJZP055RL7	55°C	±4°C	-55°C to +125°C	5-Lead SOT-23	RJ-5	3,000	T0B
ADT6501SRJZP065RL7	65°C	±4°C	-55°C to +125°C	5-Lead SOT-23	RJ-5	3,000	T1W
ADT6501SRJZP075RL7	75°C	±6°C	-55°C to +125°C	5-Lead SOT-23	RJ-5	3,000	T1X
ADT6501SRJZP085RL7	85°C	±6°C	-55°C to +125°C	5-Lead SOT-23	RJ-5	3,000	T0W
ADT6501SRJZP085-RL	85°C	±6°C	-55°C to +125°C	5-Lead SOT-23	RJ-5	10,000	T0W
ADT6501SRJZP095RL7	95°C	±6°C	-55°C to +125°C	5-Lead SOT-23	RJ-5	3,000	T1Y
ADT6501SRJZP105RL7	105°C	±6°C	-55°C to +125°C	5-Lead SOT-23	RJ-5	3,000	T15
ADT6501SRJZP105-RL	105°C	±6°C	-55°C to +125°C	5-Lead SOT-23	RJ-5	10,000	T15
ADT6501SRJZP115RL7	115°C	±6°C	-55°C to +125°C	5-Lead SOT-23	RJ-5	3,000	T1Z
ADT6502SRJZP035RL7	35°C	±4°C	-55°C to +125°C	5-Lead SOT-23	RJ-5	3,000	T25
ADT6502SRJZP045RL7	45°C	±4°C	-55°C to +125°C	5-Lead SOT-23	RJ-5	3,000	T26
ADT6502SRJZP055RL7	55°C	±4°C	-55°C to +125°C	5-Lead SOT-23	RJ-5	3,000	T27
ADT6502SRJZP065RL7	65°C	±4°C	-55°C to +125°C	5-Lead SOT-23	RJ-5	3,000	T28
ADT6502SRJZP075RL7	75°C	±6°C	-55°C to +125°C	5-Lead SOT-23	RJ-5	3,000	T17
ADT6502SRJZP085RL7	85°C	±6°C	-55°C to +125°C	5-Lead SOT-23	RJ-5	3,000	T29
ADT6502SRJZP095RL7	95°C	±6°C	-55°C to +125°C	5-Lead SOT-23	RJ-5	3,000	T2B
ADT6502SRJZP105RL7	105°C	±6°C	-55°C to +125°C	5-Lead SOT-23	RJ-5	3,000	T2C
ADT6502SRJZP115RL7	115°C	±6°C	-55°C to +125°C	5-Lead SOT-23	RJ-5	3,000	T2D
ADT6503SRJZN045RL7	-45°C	±6°C	-55°C to +125°C	5-Lead SOT-23	RJ-5	3,000	T2E
ADT6503SRJZN035RL7	-35°C	±6°C	-55°C to +125°C	5-Lead SOT-23	RJ-5	3,000	T2F
ADT6503SRJZN025RL7	-25°C	±6°C	-55°C to +125°C	5-Lead SOT-23	RJ-5	3,000	T19
ADT6503SRJZN015RL7	-15°C	±4°C	-55°C to +125°C	5-Lead SOT-23	RJ-5	3,000	T2J
ADT6503SRJZN005RL7	-5°C	±4°C	-55°C to +125°C	5-Lead SOT-23	RJ-5	3,000	T2M

Model¹	Threshold Temperature	Accuracy @ Threshold Temperature	Temperature Range	Package Description	Package Option	Ordering Quantity	Branding
ADT6503SRJZP005RL7	+5°C	±4°C	-55°C to +125°C	5-Lead SOT-23	RJ-5	3,000	T2N
ADT6503SRJZP015RL7	+15°C	±4°C	-55°C to +125°C	5-Lead SOT-23	RJ-5	3,000	T2P
ADT6504SRJZN045RL7	-45°C	±6°C	-55°C to +125°C	5-Lead SOT-23	RJ-5	3,000	T2K
ADT6504SRJZN035RL7	-35°C	±6°C	-55°C to +125°C	5-Lead SOT-23	RJ-5	3,000	T2L
ADT6504SRJZN025RL7	-25°C	±6°C	-55°C to +125°C	5-Lead SOT-23	RJ-5	3,000	T2Q
ADT6504SRJZN015RL7	-15°C	±4°C	-55°C to +125°C	5-Lead SOT-23	RJ-5	3,000	T2R
ADT6504SRJZN005RL7	-5°C	±4°C	-55°C to +125°C	5-Lead SOT-23	RJ-5	3,000	T2T
ADT6504SRJZP005RL7	+5°C	±4°C	-55°C to +125°C	5-Lead SOT-23	RJ-5	3,000	T2H
ADT6504SRJZP015RL7	+15°C	±4°C	-55°C to +125°C	5-Lead SOT-23	RJ-5	3,000	T2U

¹ Z = RoHS Compliant Part.

NOTES

NOTES