

FEATURES

Precision 1.000 V Voltage Reference
Ultracompact 3 mm × 3 mm SOT-23 Package
No External Capacitor Required
Low Output Noise: 4 μV p-p (0.1 Hz to 10 Hz)
Initial Accuracy: ±0.35% Max
Temperature Coefficient: 70 ppm/°C Max
Operating Current Range: 100 μA to 10 mA
Output Impedance: 0.3 Ω Max
Temperature Range: -40°C to +85°C

APPLICATIONS

Precision Data Acquisition Systems
Battery-Powered Equipment:
 Cellular Phone, Notebook Computer, PDA,
 and GPS
3 V/5 V, 8-/12-Bit Data Converters
Portable Medical Instruments
Industrial Process Control Systems
Precision Instruments

GENERAL DESCRIPTION

Designed for space critical applications, the ADR510 is a low voltage (1.000 V), precision shunt-mode voltage reference in the ultracompact (3 mm × 3 mm) SOT-23 package. The ADR510 features low temperature drift (70 ppm/°C), high accuracy (±0.35%), and ultralow noise (4 μV p-p) performance.

The ADR510's advanced design eliminates the need for an external capacitor, yet it is stable with any capacitive load. The minimum operating current increases from a scant 100 μA to a maximum of 10 mA. This low operating current and ease of use make the ADR510 ideally suited for hand-held battery-powered applications.

PIN CONFIGURATION

3-Lead SOT-23

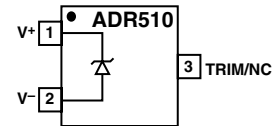

ADR510

Model	Output Voltage (V _O)	Initial Accuracy		Temperature Coefficient (ppm/°C)
		(mV)	(%)	
ADR510ART-REEL7	1.000	3.5	0.35	70

A TRIM terminal is available on the ADR510 to provide adjustment of the output voltage over ±0.5% without affecting the temperature coefficient of the device. This feature provides users with the flexibility to trim out any system errors.

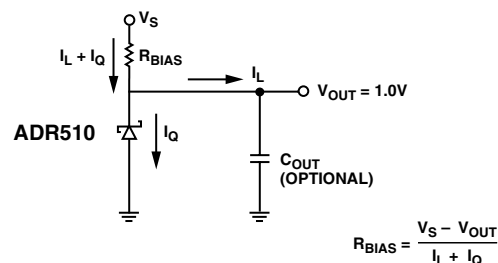

Figure 1. Typical Operating Circuit

REV. 0

Information furnished by Analog Devices is believed to be accurate and reliable. However, no responsibility is assumed by Analog Devices for its use, nor for any infringements of patents or other rights of third parties that may result from its use. No license is granted by implication or otherwise under any patent or patent rights of Analog Devices. Trademarks and registered trademarks are the property of their respective companies.

ADR510—SPECIFICATIONS

ELECTRICAL CHARACTERISTICS (I_{IN} = 100 μA to 10 mA @ T_A = 25°C, unless otherwise noted.)

Parameter	Symbol	Conditions	Min	Typ	Max	Unit
OUTPUT VOLTAGE ¹	V _O		0.9965	1.0	1.0035	V
INITIAL ACCURACY	V _{OERR}		-3.5		+3.5	mV
	V _{OERR%}		-0.35		+0.35	%
TEMPERATURE COEFFICIENT A GRADE	TCV _O	0°C < T _A < 70°C			70	ppm/°C
		-40°C < T _A < +85°C			85	ppm/°C
OUTPUT VOLTAGE CHANGE VS. I _{IN}	ΔV _R	I _{IN} = 0.1 mA to 10 mA			3	mV
DYNAMIC OUTPUT IMPEDENCE	(ΔV _R /ΔI _R)	I _{IN} = 1 mA ± 100 μA			0.3	Ω
MINIMUM OPERATING CURRENT	I _{IN}	0°C < T _A < 70°C	100			μA
VOLTAGE NOISE	e _N p-p	f = 0.1 Hz to 10 Hz		4		μV p-p
TURN-ON SETTLING TIME ²	t _R	To within 0.1% of Output		10		μs
OUTPUT VOLTAGE HYSTERESIS	V _{O_HYS}			50		ppm

NOTES

¹The forward diode voltage characteristic at -1 mA is typically 0.65 V.

²Measured without a load capacitor.

Specifications subject to change without notice.

ABSOLUTE MAXIMUM RATINGS*

Reverse Current	25 mA
Forward Current	20 mA
Storage Temperature Range	
RT Package	-65°C to +150°C
Operating Temperature Range	-40°C to +85°C
Junction Temperature Range	
RT Package	-65°C to +150°C
Lead Temperature Range (Soldering, 60 Sec)	300°C

*Absolute maximum ratings apply at 25°C, unless otherwise noted. Stresses above those listed under Absolute Maximum Ratings may cause permanent damage to the device. This is a stress rating only; functional operation of the device at these or any other conditions above those indicated in the operational section of this specification is not implied. Exposure to absolute maximum rating conditions for extended periods may affect device reliability.

Package Type ¹	θ _{JA} ²	θ _{JC}	Unit
3-SOT-23 (RT)	230	146	°C/W

NOTES

¹Package power dissipation = (T_{JMAX} - T_A)/θ_{JA}.

²θ_{JA} is specified for worst-case conditions, i.e., θ_{JA} is specified for device soldered in circuit board for surface-mount packages.

ORDERING GUIDE

Model	Output Voltage (V _O)	Initial Accuracy (mV) (%)	Temperature Coefficient (ppm/°C)	Package Description	Package Option	Branding	Number of Parts per Reel	Temperature Range
ADR510ART-REEL7	1.0	3.5 0.35	70	SOT-23	RT-3	RAA	3,000	-40°C to +85°C
ADR510ART-R2	1.0	3.5 0.35	70	SOT-23	RT-3	RAA	250	-40°C to +85°C

CAUTION

ESD (electrostatic discharge) sensitive device. Electrostatic charges as high as 4000 V readily accumulate on the human body and test equipment and can discharge without detection. Although the ADR510 features proprietary ESD protection circuitry, permanent damage may occur on devices subjected to high energy electrostatic discharges. Therefore, proper ESD precautions are recommended to avoid performance degradation or loss of functionality.



Typical Performance Characteristics—ADR510

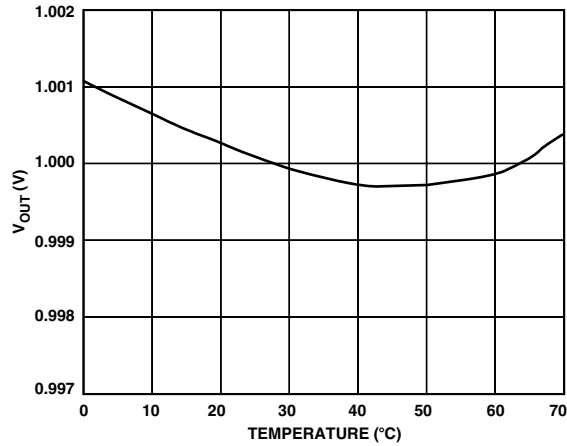

TPC 1. Typical V_{OUT} vs. Temperature

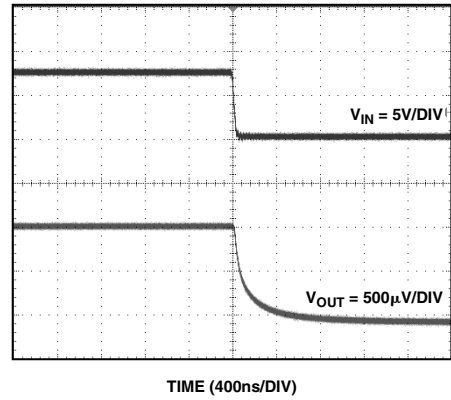

TPC 4. Turn-Off Time

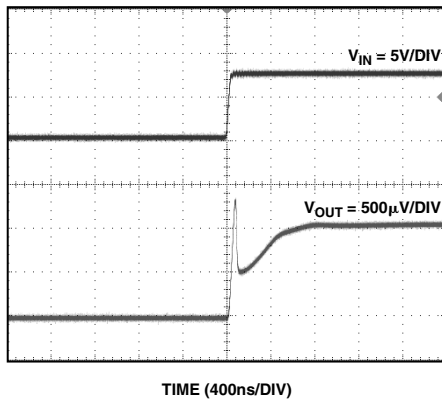

TPC 2. Turn-On Time

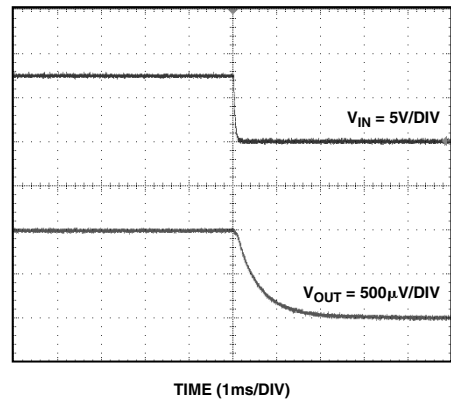

TPC 5. Turn-Off Time with 1 μ F Input Capacitor

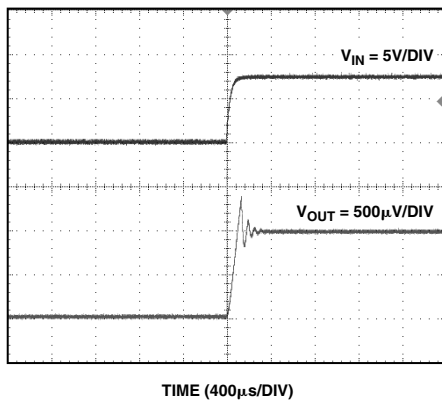

TPC 3. Turn-On Time with 1 μ F Input Capacitor

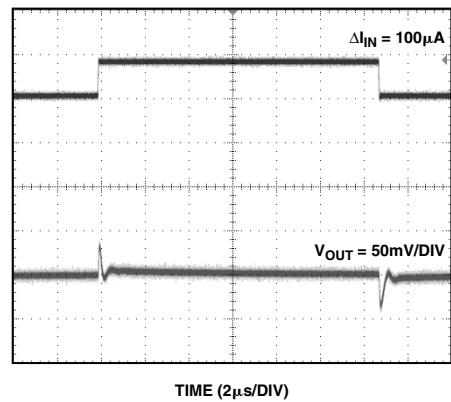

TPC 6. Output Response to 100 μ A Input Current Change

ADR510

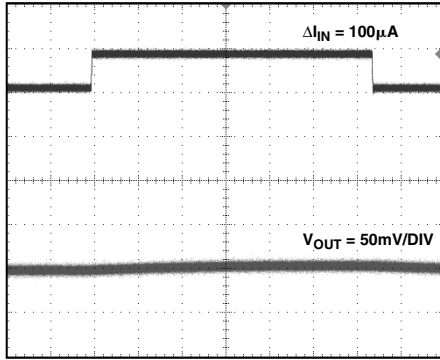

TIME (2µs/DIV)

TPC 7. Output Response to 100 µA Input Current Change with 1 µF Capacitor

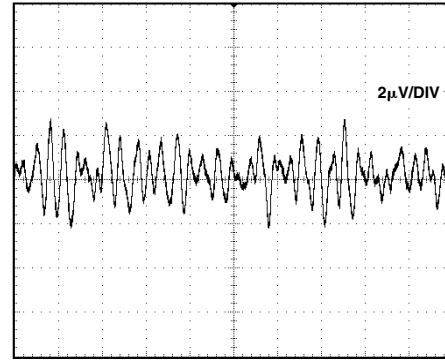

TIME (400ms/DIV)

TPC 8. 1 Hz to 10 Hz Noise

PARAMETER DEFINITIONS

Temperature Coefficient

This is the change of output voltage with respect to the operating temperature changes, normalized by the output voltage at 25°C. This parameter is expressed in ppm/°C and can be determined with the following equation

$$TCV_o \left[\frac{\text{ppm}}{^\circ\text{C}} \right] = \frac{V_o(T_2) - V_o(T_1)}{V_o(25^\circ\text{C}) \times (T_2 - T_1)} \times 10^6 \quad (1)$$

where:

$$V_o(25^\circ\text{C}) = V_o \text{ at } 25^\circ\text{C}$$

$$V_o(T_1) = V_o \text{ at Temperature 1}$$

$$V_o(T_2) = V_o \text{ at Temperature 2}$$

Thermal Hysteresis

Thermal hysteresis is defined as the change of output voltage after the device is cycled through the temperature from 25°C to 0°C to 70°C and back to 25°C. This is a typical value from a sample of parts put through such a cycle.

$$V_{o_HYS} = V_o(25^\circ\text{C}) - V_{o_TC}$$

$$V_{o_HYS} [\text{ppm}] = \frac{V_o(25^\circ\text{C}) - V_{o_TC}}{V_o(25^\circ\text{C})} \times 10^6 \quad (2)$$

where:

$$V_o(25^\circ\text{C}) = V_o \text{ at } 25^\circ\text{C}$$

$$V_{o_TC} = V_o \text{ at } 25^\circ\text{C} \text{ after temperature cycle at } 25^\circ\text{C} \text{ to } -40^\circ\text{C} \text{ to } 85^\circ\text{C} \text{ and back to } 25^\circ\text{C}$$

APPLICATIONS SECTION

The ADR510 is a 1.0 V precision shunt voltage reference. It is designed to operate without an external output capacitor between the positive and negative terminals for stability. An external capacitor can be used for additional filtering of the supply.

As with all shunt voltage references, an external bias resistor (R_{BIAS}) is required between the supply voltage and the ADR510 (see Figure 1). R_{BIAS} sets the current that is required to pass through the load (I_L) and the ADR510 (I_Q). The load and the supply voltage can vary, thus R_{BIAS} is chosen based on

- R_{BIAS} must be small enough to supply the minimum I_Q current to the ADR510 even when the supply voltage is at its minimum and the load current is at its maximum value.
- R_{BIAS} also needs to be large enough so that I_Q does not exceed 10 mA when the supply voltage is at its maximum and the load current is at its minimum.

Given these conditions, R_{BIAS} is determined by the supply voltage (V_S), the load and operating current (I_L and I_Q) of the ADR510, and the ADR510's output voltage.

$$R_{BIAS} = (V_S - V_{OUT}) / (I_L + I_Q) \quad (3)$$

Adjustable Precision Voltage Source

The ADR510, combined with a precision low input bias op amp such as the AD8610, can be used to output a precise adjustable voltage. Figure 2 illustrates the implementation of this application using the ADR510.

The output of the op amp, V_{OUT} , is determined by the gain of the circuit, which is completely dependent on Resistors R2 and R1.

$$V_{OUT} = 1 + \frac{R2}{R1} \quad (4)$$

An additional capacitor in parallel with R2 can be added to filter out high frequency noise. The value of C2 is dependent on the value of R2.

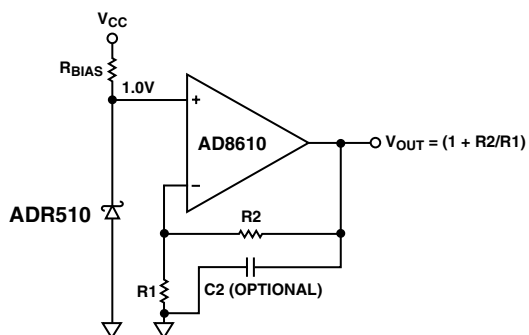

Figure 2. Adjustable Precision Voltage Source

Output Voltage Trim

Using a mechanical or digital potentiometer, the output voltage of the ADR510 can be trimmed $\pm 0.5\%$. The circuit in Figure 3 illustrates how the output voltage can be trimmed, using a 10 k Ω potentiometer. Note that trimming using other resistor values may not produce an accurate output from the ADR510.

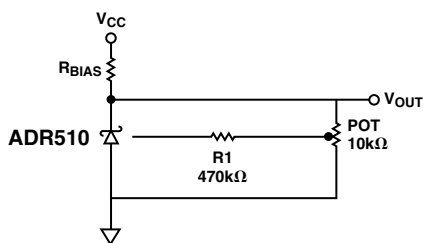

Figure 3. Output Voltage Trim

Using the ADR510 with Precision Data Converters

The compact ADR510 and its low minimum operating current requirement make it ideal for use in battery-powered portable instruments, such as the AD7533 CMOS multiplying DAC, that use precision data converters.

Figure 4 shows the ADR510 serving as an external reference to the AD7533, a CMOS multiplying DAC. Such a DAC requires a negative voltage input in order to provide a positive output range. In this application, the ADR510 is supplying a -1.0 V reference to the REF input of the AD7533.

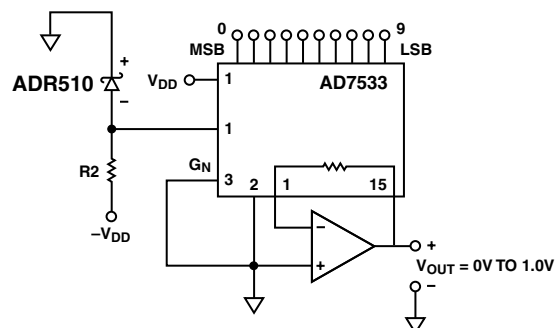

Figure 4. ADR510 as a Reference for a 10-Bit CMOS DAC (AD7533)

Precise Negative Voltage Reference

The ADR510 is suitable for use in applications where a precise negative voltage reference is desired, including the application detailed in Figure 4.

Figure 5 shows the ADR510 configured to provide a -1.0 V output.

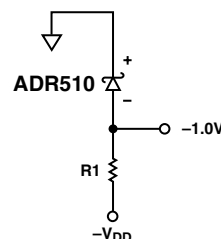

Figure 5. Precise -1.0 V Reference Configuration

Since the ADR510 characteristics resemble those of a Zener diode, the cathode shown in Figure 5 will be 1.0 V higher with respect to the anode ($V+$ with respect to $V-$ on the ADR510 package). Since the cathode of the ADR510 is tied to ground, the anode must be -1.0 V.

R1 in Figure 5 should be chosen so that 100 μ A to 10 mA is provided to properly bias the ADR510.

$$R1 = \frac{V_{DD}}{I} \quad (5)$$

The R1 resistor should be chosen so that power dissipation is at a minimum. An ideal resistor value can be determined through manipulation of Equation 5.

OUTLINE DIMENSIONS

3-Lead Small Outline Transistor Package [SOT-23] (RT-3)

Dimensions shown in millimeters

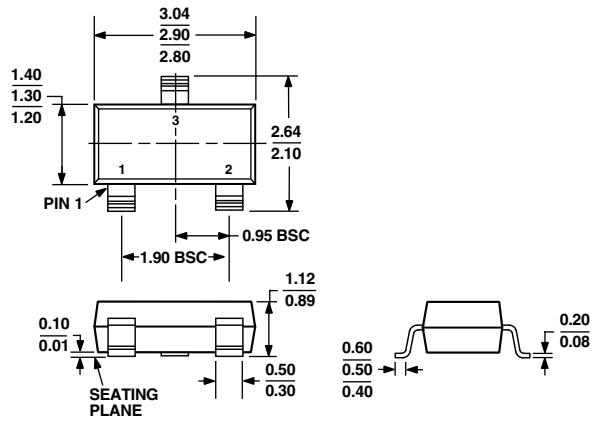

COMPLIANT TO JEDEC STANDARDS TO-236AB

