

### FEATURES

Wide operating range: 50  $\mu$ A to 10 mA

Initial accuracy:  $\pm 0.2\%$  max

Output impedance: 1  $\Omega$  max

Wideband noise (10 Hz to 10 kHz): 20  $\mu$ V rms

Operating temperature:  $-40^{\circ}\text{C}$  to  $+85^{\circ}\text{C}$

Compact, surface-mount SC70 package

### APPLICATIONS

Computer servers

Battery-powered instrumentation

Portable medical equipment

Automotive

### GENERAL DESCRIPTION

The ADR1500 is a low cost, 2-terminal (shunt), precision band gap reference. It provides an accurate 1.2875 V output for input currents between 50  $\mu$ A to 10 mA.

The low minimum operating current makes the ADR1500 ideal for use in battery-powered 3 V or 5 V systems. However, the wide operating current range means the ADR1500 is extremely versatile and suitable for use in a wide variety of high current applications.

The ADR1500 is available in the tiny SC70 package and is specified over the  $-40^{\circ}\text{C}$  to  $+85^{\circ}\text{C}$  operating temperature range.

### PIN CONFIGURATION

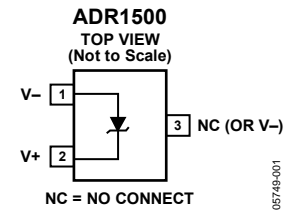

Figure 1. 3-Lead SC70 (KS Suffix)

#### Rev. 0

Information furnished by Analog Devices is believed to be accurate and reliable. However, no responsibility is assumed by Analog Devices for its use, nor for any infringements of patents or other rights of third parties that may result from its use. Specifications subject to change without notice. No license is granted by implication or otherwise under any patent or patent rights of Analog Devices. Trademarks and registered trademarks are the property of their respective owners.

## TABLE OF CONTENTS

Features .....	1	Typical Performance Characteristics .....	5
Applications.....	1	Theory of Operation .....	6
Pin Configuration.....	1	Applying the ADR1500 .....	6
General Description .....	1	Turn-On Time .....	6
Revision History .....	2	Transient Response .....	7
Specifications.....	3	Outline Dimensions .....	8
Electrical Characteristics .....	3	Ordering Guide .....	8
Absolute Maximum Ratings.....	4		
ESD Caution.....	4		

## REVISION HISTORY

1/06—Revision 0: Initial Version

## SPECIFICATIONS

### ELECTRICAL CHARACTERISTICS

$T_A = 25^\circ\text{C}$ ,  $I_{IN} = 100\ \mu\text{A}$ , unless otherwise noted.

Table 1.

Parameter	Min	Typ	Max	Unit
REVERSE VOLTAGE OUTPUT	1.2849	1.2875	1.2901	V
REVERSE VOLTAGE TEMPERATURE DRIFT, $-40^\circ\text{C}$ to $+85^\circ\text{C}$		170	220	ppm/ $^\circ\text{C}$
MINIMUM OPERATING CURRENT, $-40^\circ\text{C}$ to $+85^\circ\text{C}$			50	$\mu\text{A}$
REVERSE VOLTAGE CHANGE WITH REVERSE CURRENT				
$50\ \mu\text{A} < I_{IN} < 10\ \text{mA}$ , $-40^\circ\text{C}$ to $+85^\circ\text{C}$		3.0	6	mV
$50\ \mu\text{A} < I_{IN} < 1\ \text{mA}$ , $-40^\circ\text{C}$ to $+85^\circ\text{C}$		0.7		mV
DYNAMIC OUTPUT IMPEDANCE ( $\Delta V_R/\Delta I_R$ )				
$I_{IN} = 1\ \text{mA} \pm 100\ \mu\text{A}$ ( $f = 120\ \text{Hz}$ )		0.4	1	$\Omega$
OUTPUT NOISE				
RMS Noise Voltage: 10 Hz to 10 kHz		20		$\mu\text{V rms}$
Low Frequency Noise Voltage: 0.1 Hz to 10 Hz		5		$\mu\text{V p-p}$
TURN-ON SETTLING TIME TO 0.1%, NO $C_{OUT}$		5		$\mu\text{s}$
OUTPUT VOLTAGE HYSTERESIS		80		$\mu\text{V}$
TEMPERATURE RANGE				
Specified Range	$-40$		$+85$	$^\circ\text{C}$
Operating Range	$-55$		$+125$	$^\circ\text{C}$

# ADR1500

## ABSOLUTE MAXIMUM RATINGS

Table 2.

Parameter	Rating
Reverse Current	25 mA
Forward Current	20 mA
SC70 (KS) Package Dissipation	
$\theta_{JA}$	376°C/W
$\theta_{JC}$	189°C/W
Storage Temperature Range	-65°C to +150°C
Operating Temperature Range	-55°C to +150°C
Lead Temperature, Soldering	
Vapor Phase (60 sec)	215°C
Infrared (15 sec)	220°C

Stresses above those listed under Absolute Maximum Ratings may cause permanent damage to the device. This is a stress rating only; functional operation of the device at these or any other conditions above those indicated in the operational section of this specification is not implied. Exposure to absolute maximum rating conditions for extended periods may affect device reliability.

### ESD CAUTION

ESD (electrostatic discharge) sensitive device. Electrostatic charges as high as 4000V readily accumulate on the human body and test equipment and can discharge without detection. Although this product features proprietary ESD protection circuitry, permanent damage may occur on devices subjected to high energy electrostatic discharges. Therefore, proper ESD precautions are recommended to avoid performance degradation or loss of functionality.



# TYPICAL PERFORMANCE CHARACTERISTICS

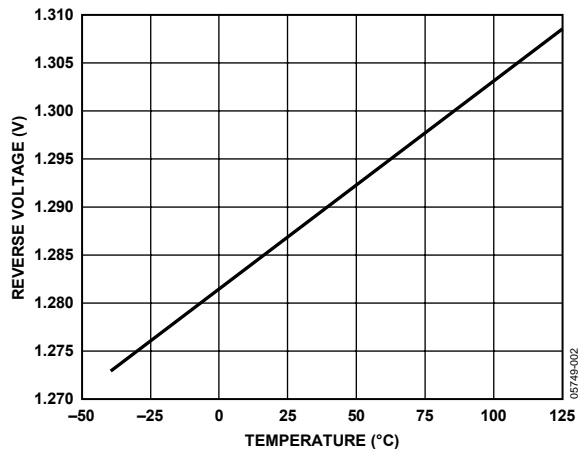

Figure 2. Output Drift for Different Temperature Characteristics

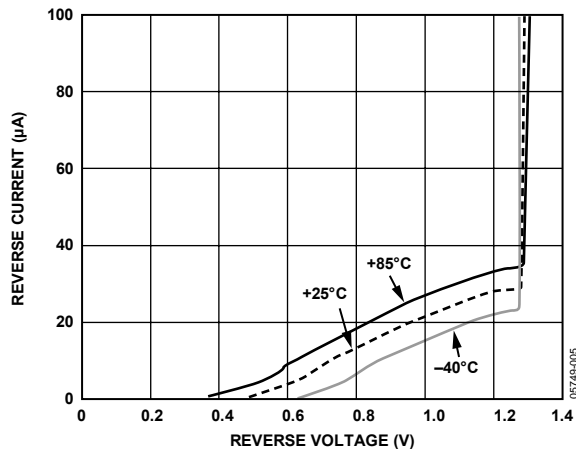

Figure 5. Reverse Current vs. Reverse Voltage

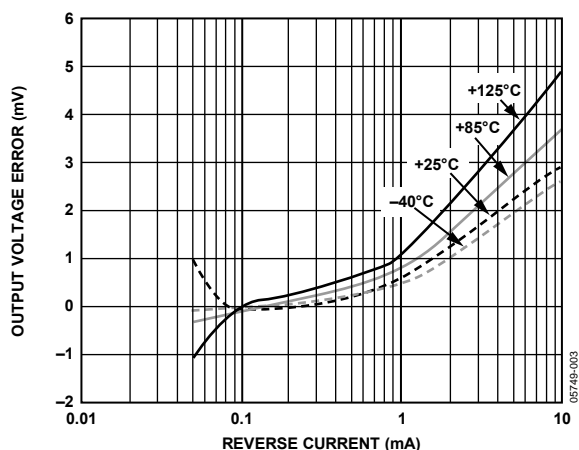

Figure 3. Output Voltage Error vs. Reverse Current

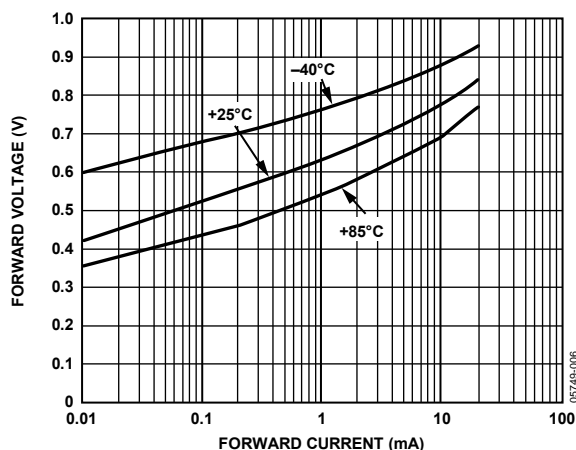

Figure 6. Forward Voltage vs. Forward Current

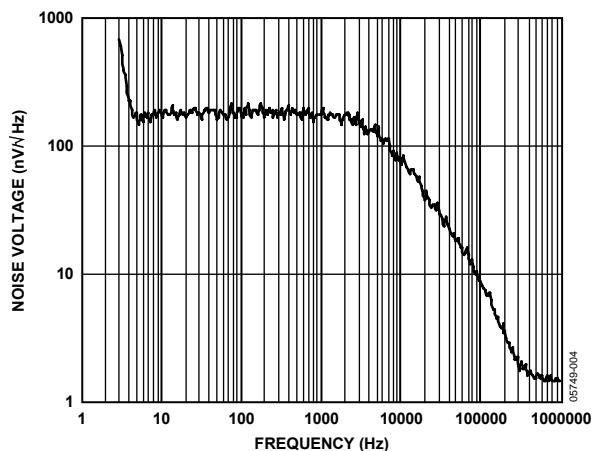

Figure 4. Noise Spectral Density

## THEORY OF OPERATION

The ADR1500 uses the band gap concept to produce a stable voltage reference suitable for high accuracy data acquisition components and systems. This device makes use of the underlying physical nature of the silicon transistor base emitter voltage in the forward-biased operating region. All such transistors have an approximate  $-2 \text{ mV}/^\circ\text{C}$  temperature coefficient, which is not suitable for use as a low TC reference; however, extrapolation of the temperature characteristic of any one of these devices to absolute zero (with collector current proportional to absolute temperature) reveals that  $V_{BE}$  goes to approximately the silicon band gap voltage. Therefore, if a voltage could be developed with an opposing temperature coefficient to the sum with the  $V_{BE}$ , then a zero TC reference would result. The ADR1500 circuit in Figure 7 provides such a compensating voltage,  $V_1$ , by deriving two transistors at different current densities and amplifying the resultant  $V_{BE}$  difference ( $\Delta V_{BE}$ , which has a positive TC). The sum of the  $V_{BE}$  and  $V_1$  provides a stable voltage reference.

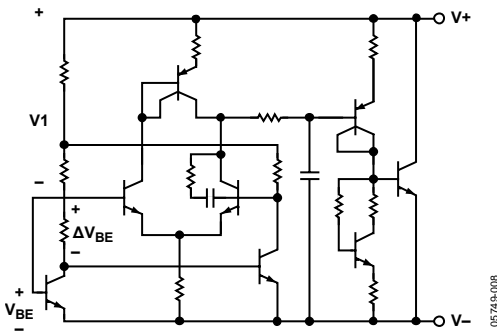

Figure 7. Schematic Diagram

## APPLYING THE ADR1500

The ADR1500 is simple to use in virtually all applications. To operate the ADR1500 as a conventional shunt reference, see Figure 8. An external series resistor is connected between the supply voltage and the ADR1500.

For a given supply voltage, the series resistor,  $R_S$ , determines the reverse current flowing through the ADR1500. The value of  $R_S$  must be chosen to accommodate the expected variations of the supply voltage,  $V_S$ , load current,  $I_L$ , and the ADR1500 reverse voltage,  $V_R$ , while maintaining an acceptable reverse current,  $I_R$ , through the ADR1500.

The minimum value for  $R_S$  should be enough to limit  $I_R$  to 10 mA when  $V_S$  is at its maximum, and  $I_L$  and  $V_R$  are at their minimum. The equation for selecting  $R_S$  is

$$R_S = \frac{(V_S - V_R)}{(I_R + I_L)}$$

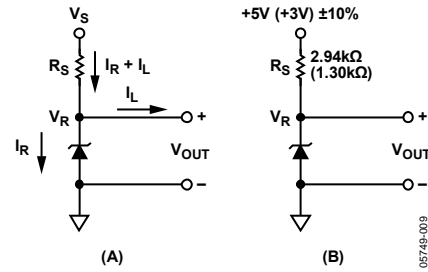

Figure 8. Typical Connection Diagram

Figure 8 shows a typical connection of the ADR1500 operating at a minimum of 100  $\mu\text{A}$ . This connection can provide  $\pm 1 \text{ mA}$  to the load, while accommodating  $\pm 10\%$  power supply variations.

## TURN-ON TIME

The turn-on time is a critical parameter for applications demanding a large amount of processing. Figure 9 shows the turn-on characteristics of the ADR1500.

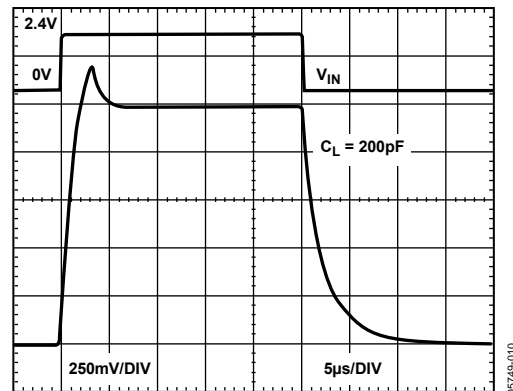

Figure 9. Response Time

Upon application of power (cold start), the time required for the output voltage to reach its final value within a specified error is the turn-on settling time. Two components are normally associated with the time for active circuits to settle and the time for the thermal gradients on the chip to stabilize. This characteristic is generated from cold start operation and represents the true turn-on waveform after power up. Figure 10 shows both the course and fine turn-on settling characteristics of the device; the total settling time to within 1.0 mV is about 6  $\mu\text{s}$ , and there is no long thermal tail when the horizontal scale is expanded to 2  $\mu\text{s}/\text{DIV}$ . The output turn-on time is modified when an external noise reduction filter is used. When present, the time constant of the filter dominates the overall settling.

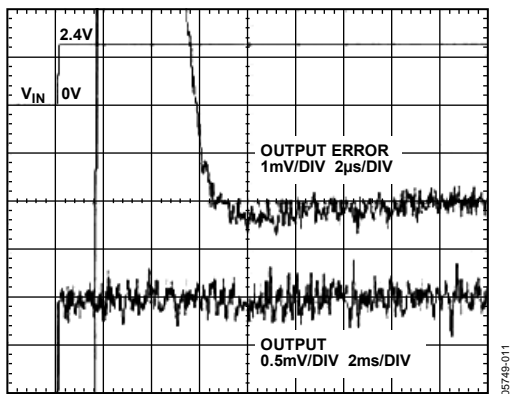

Figure 10. Turn-On Settling Time

Attempts to drive a large capacitive load (in excess of 1000 pF) can result in ringing. This is due to the additional poles formed by the load capacitance and the output impedance of the reference. A recommended method for driving capacitive loads of this magnitude is shown in Figure 11.

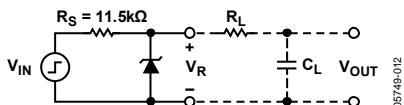

Figure 11. Turn-On, Settling, and Transient Test Circuit

### TRANSIENT RESPONSE

Many ADCs and DACs present transient current loads to the reference. Poor reference response can degrade the converter's performance. Figure 12 displays both the coarse and fine settling characteristics of the device to load transient of  $\pm 50 \mu\text{A}$ .

It shows the settling characteristics of the device for an increased reverse current of  $50 \mu\text{A}$  and the response when the reverse current is decreased by  $50 \mu\text{A}$ . The transients settle to 1 mV in about  $3 \mu\text{s}$ .

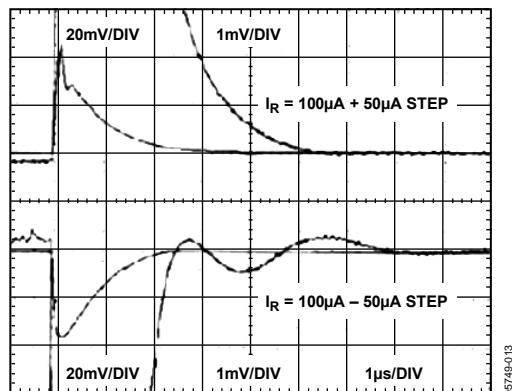
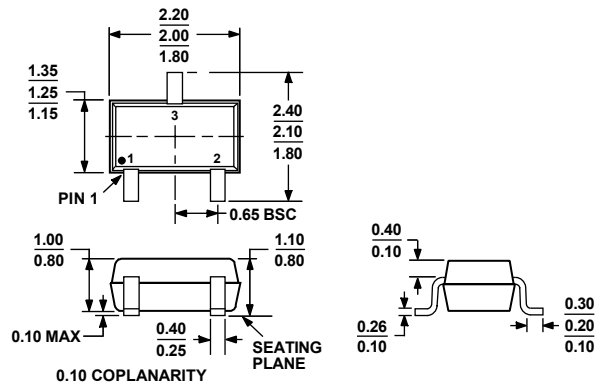

Figure 12. Transient Settling Time

A resistor isolates the capacitive load from the output stage, while the capacitor provides a single-pole, low-pass filter and lowers the output noise.

OUTLINE DIMENSIONS



ALL DIMENSIONS COMPLIANT WITH EIAJ SC70

Figure 13. 3-Lead Thin Shrink Small Outline Transistor Package [SC70] (KS-3)

Dimensions shown in millimeters

111806-0

ORDERING GUIDE

Model	Initial Output Error	Temperature Coefficient (Typ)	Temperature Range	Package Description	Package Option	Branding
ADR1500BKSZ-REEL <sup>1</sup>	2.6 mV	170 ppm/°C	-40°C to +85°C	3-Lead SC70	KS-3	R2F

<sup>1</sup> Z = Pb-free part.