

### FEATURES

- Efficient asynchronous boost converter for driving up to 6 white LEDs
- 2.7 V to 5.5 V input voltage range
- 128 programmable backlight LED current levels (30 mA maximum)
- Programmable backlight fade-in/fade-out times
- Programmable backlight dim and off times
- Ambient light sensing with autonomous backlight adjustment
- 3 auxiliary LED current sinks
- 64 programmable auxiliary LED current levels (14 mA maximum)
- Programmable auxiliary LED fade-in/fade-out times
- Programmable auxiliary LED on and off times (allows blinking)
- I<sup>2</sup>C-compatible serial interface
- Interrupt line for signaling an external processor (INT)
- Hard reset (RST)
- Current limit protection
- Thermal overload protection
- Available in small 4.0 mm × 4.0 mm, 24-lead LFCSP package

### APPLICATIONS

- Display backlight driver with ambient light sensor input and control and multiple LED indicator sinks

### GENERAL DESCRIPTION

The ADP5501 is a versatile, single-chip, white LED backlight driver with programmable ambient light sensor input and programmable LED current. This device is designed for media-enabled handset applications. The ADP5501 uses an I<sup>2</sup>C-compatible serial interface and a single line interrupt to communicate with the host processor.

### TYPICAL OPERATING CIRCUIT

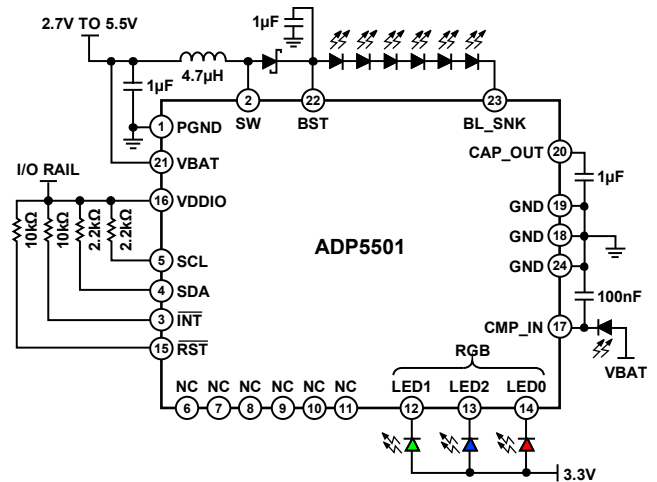

Figure 1.

07780-001

The ADP5501 can detect ambient light levels and adjust the backlight brightness accordingly, resulting in extended battery life. Once configured, the ADP5501 is capable of controlling the display backlight intensity, on/off timing, dimming, and fading without the intervention of the main processor, which translates into valuable battery power savings. The three auxiliary LEDs are also capable of fading and are timed on and off via register programming.

#### Rev. 0

Information furnished by Analog Devices is believed to be accurate and reliable. However, no responsibility is assumed by Analog Devices for its use, nor for any infringements of patents or other rights of third parties that may result from its use. Specifications subject to change without notice. No license is granted by implication or otherwise under any patent or patent rights of Analog Devices. Trademarks and registered trademarks are the property of their respective owners.

## TABLE OF CONTENTS

Features .....	1	Fade Override .....	13
Applications.....	1	Advanced Fading (Square).....	13
Typical Operating Circuit.....	1	Advanced Fading (Cubic 1 and Cubic 2) .....	13
General Description .....	1	Ambient Light Sensing .....	14
Revision History .....	2	Automatic Backlight Adjustment.....	14
Specifications.....	3	LED Current Sinks .....	15
Absolute Maximum Ratings.....	5	Interrupt Output ( $\overline{\text{INT}}$ ) .....	17
Thermal Resistance .....	5	Reset Input ( $\overline{\text{RST}}$ ) .....	17
ESD Caution.....	5	Communicaton Interface .....	18
Pin Configuration and Function Descriptions.....	6	Register Map .....	19
Typical Performance Characteristics .....	7	Detailed Register Descriptions .....	20
Theory of Operation .....	9	Applications Information .....	26
Backlight Drive Control .....	9	Converter Topology .....	26
Backlight Operating Levels .....	10	PCB Layout .....	27
Backlight Maximum and Dim Settings .....	10	Example Circuit .....	27
Backlight Turn-On/Turn-Off/Dim .....	10	Outline Dimensions .....	28
Automatic Dim and Turn-Off Timers .....	11	Ordering Guide .....	28
Linear Backlight Fade-In and Fade-Out.....	11		

## REVISION HISTORY

10/08—Revision 0: Initial Version

## SPECIFICATIONS

V<sub>BAT</sub> = 2.7 V to 5.5 V, T<sub>J</sub> = -40°C to +125°C, unless otherwise noted.

Table 1.

Parameter	Symbol	Conditions <sup>1</sup>	Min	Typ	Max	Unit
<b>SUPPLY VOLTAGE</b>						
V <sub>BAT</sub> Input Voltage Range	V <sub>BAT</sub>		2.7		5.5	V
VDDIO Input Voltage Range	V <sub>IO</sub>		1.8		3.3 <sup>2</sup>	V
Undervoltage Lockout Threshold	UVLO <sub>V<sub>BAT</sub></sub>	V <sub>BAT</sub> falling	1.7	2.1		V
	UVLO <sub>V<sub>BAT</sub></sub>	V <sub>BAT</sub> rising		2.4	2.7	V
	UVLO <sub>VDDIO</sub>	VDDIO falling	1.1	1.3		V
	UVLO <sub>VDDIO</sub>	VDDIO rising		1.4		V
SW Leakage	SW <sub>LEAKAGE</sub>	2.7 V ≤ V <sub>BAT</sub> ≤ 5.5 V		0.1	1	μA
<b>SUPPLY CURRENT</b>						
Shutdown Current <sup>3</sup>	I <sub>SD</sub>	VDDIO = 0 V		0.1	1	μA
Standby Current <sup>4</sup>	I <sub>STNBY</sub>	1.8 V ≤ VDDIO ≤ 3.3 V <sup>2</sup> , STNBY = 0		25	45	μA
<b>BACKLIGHT LED DRIVER (SW, BST)</b>						
Current Limit (Peak Inductor Current)			450	600	750	mA
On Resistance			200	200	400	mΩ
Overvoltage Threshold			24.5	27	29.5	V
Boost Startup Time				1		mS
<b>BACKLIGHT LED CURRENT SINK (BL_SNK)</b>						
Full-Scale Current Sink		Backlight code = 0x7F, bias = 0.65 V	26	30	32	mA
Backlight Current Ramp Rate		Fade timers disabled		0.3		mA/ms
<b>AMBIENT LIGHT SENSOR (CMP_IN)</b>						
Full-Scale Current	BL <sub>FULLSCALE</sub>		0.7	1	1.2	mA
<b>INPUT LOGIC LEVELS (SCL, SDA, RST)</b>						
Logic Low Input Voltage	V <sub>IL</sub>	1.8 V ≤ VDDIO ≤ 3.3 V <sup>2</sup>			0.3 × VDDIO	V
Logic High Input Voltage	V <sub>IH</sub>	1.8 V ≤ VDDIO ≤ 3.3 V <sup>2</sup>	0.7 × VDDIO			V
Input Leakage Current	V <sub>I-LEAKAGE</sub>	1.8 V ≤ VDDIO ≤ 3.3 V <sup>2</sup>		0.1	1	μA
<b>INPUT LOGIC DEBOUNCE (RST)</b>						
	V <sub>IL-DBNC</sub>		50	75	100	μs
<b>OPEN-DRAIN OUTPUT LOGIC LEVELS (INT, SDA)</b>						
Logic Low Output Voltage	V <sub>OL</sub>	I <sub>SINK</sub> = 1 mA			0.4	V
Logic High Leakage Current	V <sub>OH-LEAKAGE</sub>	1.8 V ≤ VDDIO ≤ 3.3 V <sup>2</sup>		0.1	1	μA
<b>AUX LED CURRENT SINKS (ILED, C3, R3)</b>						
Leakage	LED <sub>LEAKAGE</sub>	Sink disabled		0.1	1	μA
Full-Scale Current Sink	LED <sub>FULLSCALE</sub>	Applied pin voltage = 1 V	10.5	14	16.5	mA
<b>THERMAL SHUTDOWN</b>						
Thermal Shutdown Threshold	TS	T <sub>J</sub> rising		150		°C
Thermal Shutdown Hysteresis	TS <sub>HYS</sub>	T <sub>J</sub> falling		10		°C
<b>I<sup>2</sup>C TIMING SPECIFICATIONS</b>						
Delay from Reset Deassertion to I <sup>2</sup> C Access			60			μs
SCL Clock Frequency	f <sub>SCL</sub>			400		kHz
SCL High Time	t <sub>HIGH</sub>		0.6			μs
SCL Low Time	t <sub>LOW</sub>		1.3			μs
Data Setup Time	t <sub>SU, DAT</sub>		100			ns
Data Hold Time	t <sub>HD, DAT</sub>		0		0.9	μs
Setup Time for Repeated Start	t <sub>SU, STA</sub>		0.6			μs

# ADP5501

Parameter	Symbol	Conditions <sup>1</sup>	Min	Typ	Max	Unit
Hold Time for Start/Repeated Start	$t_{HD, STA}$		0.6			$\mu s$
Bus Free Time for Stop and Start Condition	$t_{BUF}$		1.3			$\mu s$
Setup Time for Stop Condition	$t_{SU, STO}$		0.6			$\mu s$
Rise Time for SCL and SDA	$t_R$		$20 + 0.1 C_B$	300		ns
Fall Time for SCL and SDA	$t_F$		$20 + 0.1 C_B$	300		ns
Pulse Width of Suppressed Spike	$t_{SP}$		0	50		$\mu s$
Capacitive Load for Each Bus Line	$C_B^5$			400		pF

<sup>1</sup> All limits at temperature extremes are guaranteed via correlation using standard statistical quality control (SQC). Typical values are at  $T_A = 25^\circ C$ ,  $V_{BAT} = 3.6 V$ .

<sup>2</sup> 3.3 V or  $V_{BAT}$ , whichever is smaller.

<sup>3</sup> Internal LDO powered down, digital blocks inactive,  $I^2C$  inactive, boost inactive.

<sup>4</sup> Internal LDO powered up, digital blocks active,  $I^2C$  active, boost inactive.

<sup>5</sup>  $C_B$  is the total capacitance of one bus line in picofarads (pF).

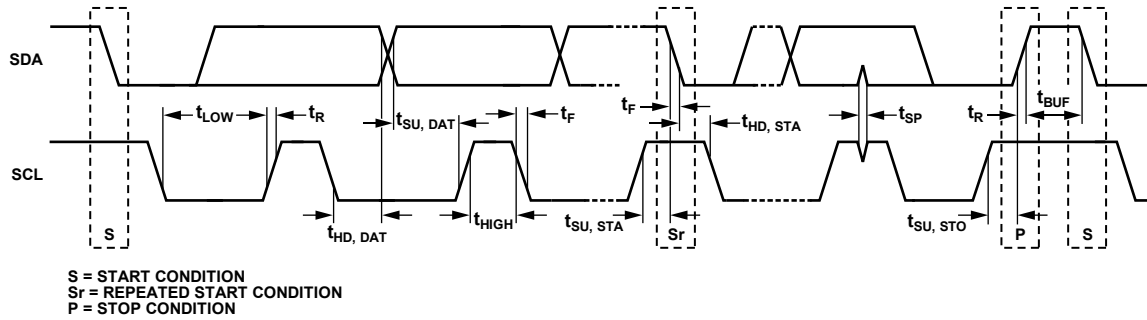

Figure 2. Interface Timing Diagram

07786-002

## ABSOLUTE MAXIMUM RATINGS

Table 2.

Parameter	Rating
VBAT to GND	-0.3 V to +6 V
VDDIO to GND	-0.3 V to VBAT
SW/BST to GND	-0.3 V to +30 V
LED0/LED1/LED2/CMP_IN/SCL/SDA/INT/ RST/CAP_OUT/BL_SNK to GND	-0.3 V to +6 V
PGND to GND	-0.3 V to +0.3 V
Operating Ambient Temperature Range	-40°C to +85°C <sup>1</sup>
Operating Junction Temperature Range	-40°C to +125°C
Storage Temperature Range	-65°C to +150°C
Soldering Conditions	JEDEC J-STD-020

<sup>1</sup>In applications where high power dissipation and poor thermal resistance are present, the maximum ambient temperature may have to be derated. Maximum ambient temperature ( $T_{A(MAX)}$ ) is dependent on the maximum operating junction temperature ( $T_{J(MAXOP)} = 125^{\circ}\text{C}$ ), the maximum power dissipation of the device ( $P_{D(MAX)}$ ), and the junction-to-ambient thermal resistance of the part/package in the application ( $\theta_{JA}$ ), using the following equation:  $T_{A(MAX)} = T_{J(MAXOP)} - (\theta_{JA} \times P_{D(MAX)})$ .

Stresses above those listed under Absolute Maximum Ratings may cause permanent damage to the device. This is a stress rating only; functional operation of the device at these or any other conditions above those indicated in the operational section of this specification is not implied. Exposure to absolute maximum rating conditions for extended periods may affect device reliability.

Absolute maximum ratings apply individually only, not in combination. Unless otherwise specified, all other voltages are referenced to GND.

### THERMAL RESISTANCE

$\theta_{JA}$  is specified for the worst-case conditions, that is, a device soldered in a circuit board for surface-mount packages.

Table 3. Thermal Resistance

Package Type	$\theta_{JA}$	Unit
24-Lead LFCSP_VQ	50	$^{\circ}\text{C}/\text{W}$

### ESD CAUTION



**ESD (electrostatic discharge) sensitive device.** Charged devices and circuit boards can discharge without detection. Although this product features patented or proprietary protection circuitry, damage may occur on devices subjected to high energy ESD. Therefore, proper ESD precautions should be taken to avoid performance degradation or loss of functionality.

## PIN CONFIGURATION AND FUNCTION DESCRIPTIONS

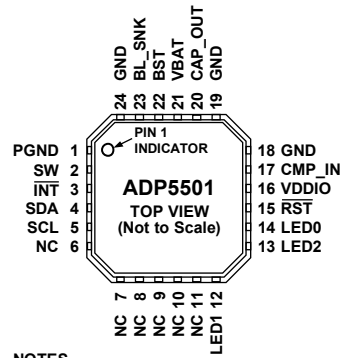

- NOTES
1. NC = NO CONNECT.
  2. EXPOSED PAD MUST BE CONNECTED TO GROUND.

07780-003

Figure 3. Pin Configuration

Table 4. Pin Function Descriptions

Pin No.	Mnemonic	Description
1	PGND	Power Switch Output to Ground.
2	SW	Power Switch Input.
3	$\overline{\text{INT}}$	Processor Interrupt, Active Low, Open Drain. $\overline{\text{INT}}$ should be pulled up to VDDIO.
4	SDA	I <sup>2</sup> C-Compatible Serial Data Line (Open Drain Requires External Pull-Up) to VDDIO.
5	SCL	I <sup>2</sup> C-Compatible Serial Clock Line (Open Drain Requires External Pull-Up) to VDDIO.
6	NC	No Connect.
7	NC	No Connect.
8	NC	No Connect.
9	NC	No Connect.
10	NC	No Connect.
11	NC	No Connect.
12	LED1	LED 1 Current Sink. LED1 can be used with LED0 and LED2 as RGB.
13	LED2	LED 2 Current Sink. LED2 can be used with LED1 and LED0 as RGB.
14	LED0	LED 0 Current Sink. LED0 can be used with LED1 and LED2 as RGB.
15	$\overline{\text{RST}}$	Reset Input, Active Low. This input signal resets the device to the power-up default conditions. It must be driven low for a minimum of 75 $\mu\text{s}$ (typical) to be valid.
16	VDDIO	Supply Voltage for the I/O Pin. The output pin can be 1.8 V to 3.3 V or VBAT, whichever is smaller. If VDDIO = 0, the device goes into full shutdown mode.
17	CMP_IN	Input for Ambient Light Sensing.
18	GND	Ground.
19	GND	Ground.
20	CAP_OUT	Capacitor for Internal 2.7 V LDO. A 1 $\mu\text{F}$ capacitor must be connected between this pin and ground. Do not use this pin to supply external loads.
21	VBAT	Main Supply Voltage for the IC (2.7 V to 5.5 V).
22	BST	Overvoltage Monitor Input for the Boost Converter.
23	BL_SNK	Backlight Current Sink.
24	GND	Ground.
	EPAD	The exposed pad must be connected to ground.

# TYPICAL PERFORMANCE CHARACTERISTICS

V<sub>BAT</sub> = 3.6 V, T<sub>A</sub> = 25°C, unless otherwise noted. Inductor = LPS4012-472MLB. Schottky rectifier = MBR140SFT1G.

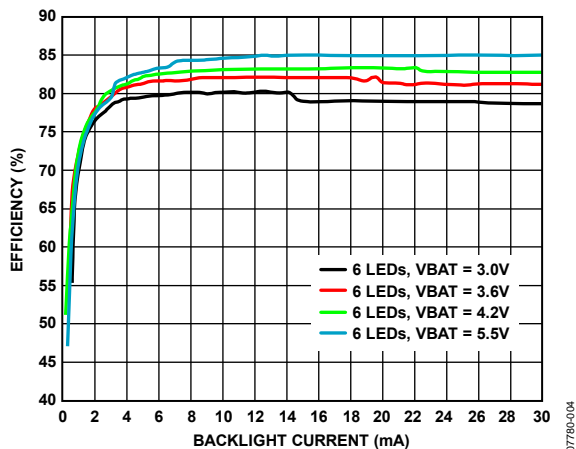

Figure 4. Efficiency vs. Backlight Current (6 LEDs)

07780-004

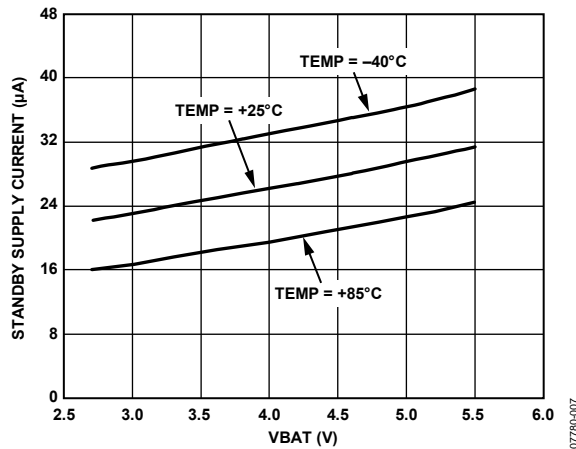

Figure 7. Standby Supply Current vs. VBAT

07780-007

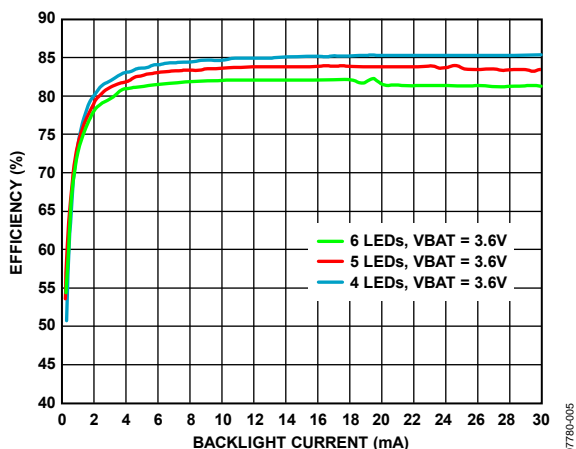

Figure 5. Efficiency vs. Backlight Current (4, 5, and 6 LEDs)

07780-005

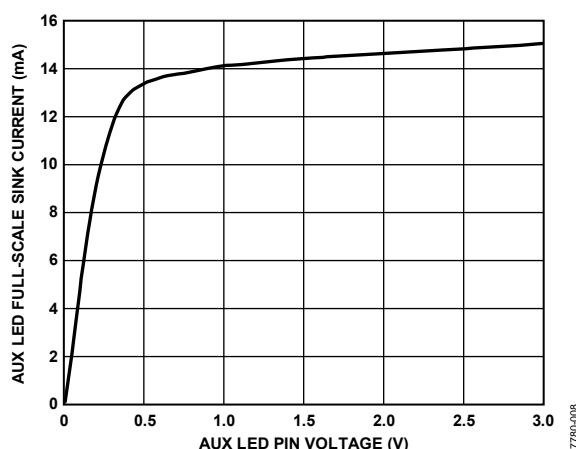

Figure 8. Typical Auxiliary LED Pin (LED0, LED1, LED2), Full-Scale Sink Current vs. Applied Pin Voltage

07780-008

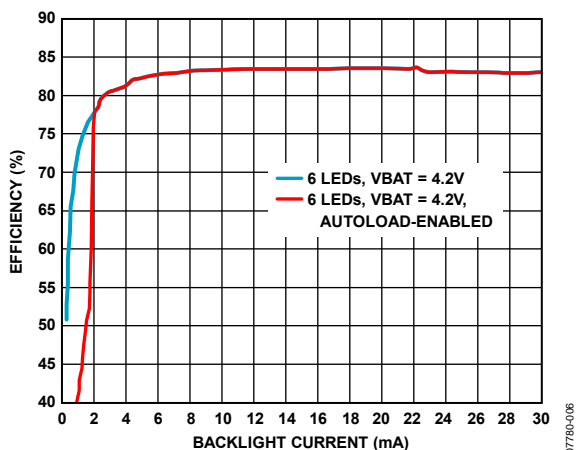

Figure 6. Efficiency vs. Backlight Current (Autoload On/Off)

07780-006

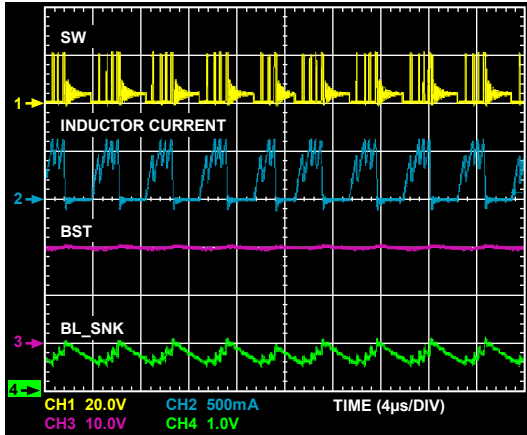

Figure 9. Boost Operation (Backlight = 30 mA)

07780-09

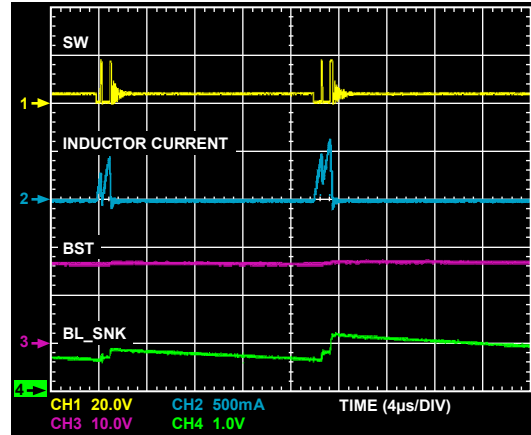

Figure 11. Boost Operation (Backlight = 2 mA)

07780-011

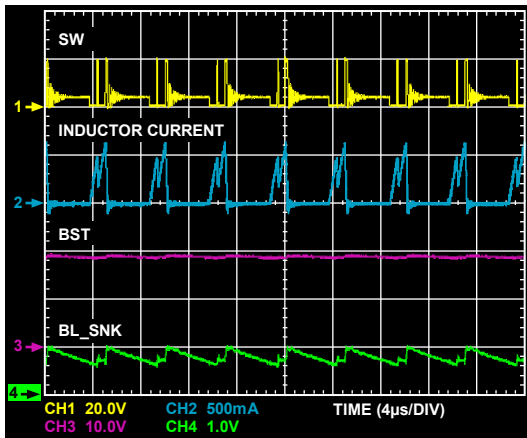

Figure 10. Boost Operation (Backlight = 15 mA)

07780-010

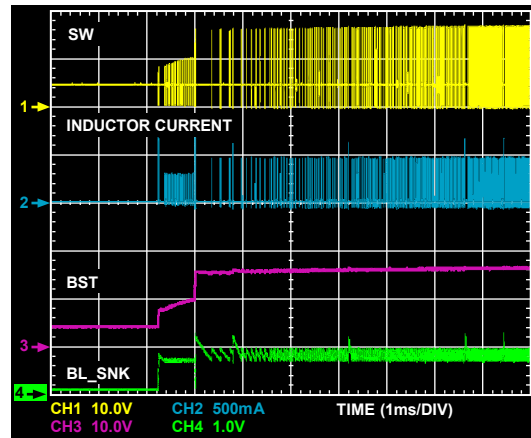

Figure 12. Boost Startup

07780-012



## THEORY OF OPERATION

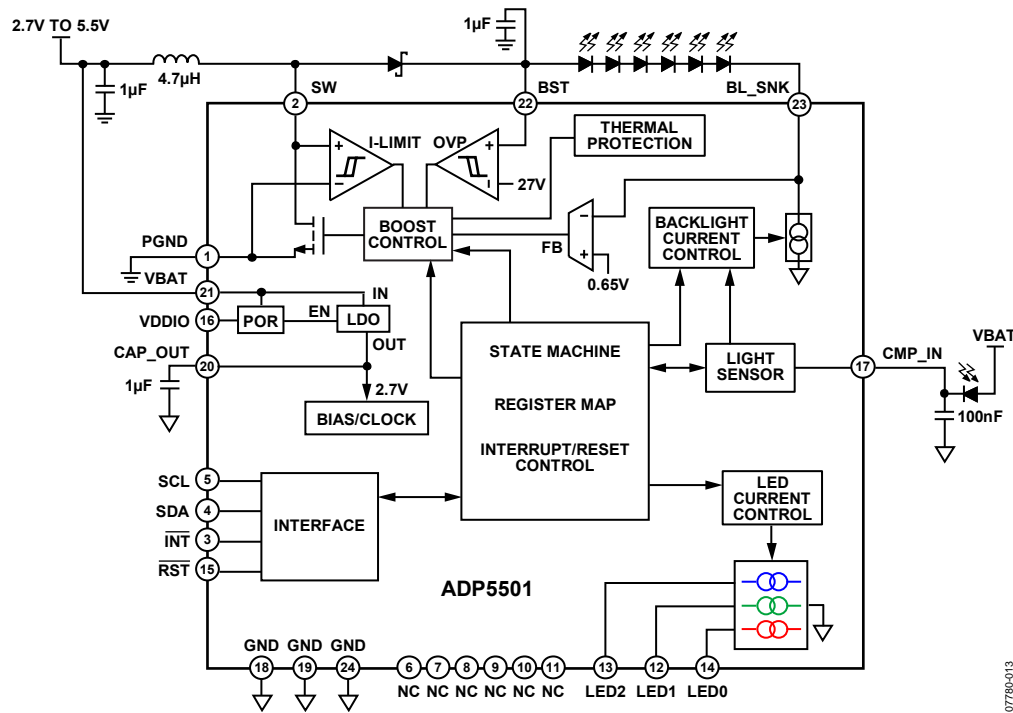

Figure 13. Internal Block Diagram

The ADP5501 is an autonomous backlight white LED driver with programmable current and ambient light sensor input. It is ideal for cellular phone designs and other portable devices, where programmable and automated light output is needed. Its versatility makes it ideal for media-enabled mobile devices. Programmable fade-in, fade-out, dim, and off timers provide the backlight with excellent flexibility and control features. Using an external photodiode, the ADP5501 can perform ambient light sensing and adjust the backlight brightness according to varying lighting conditions.

Programmable fading is also available for the three LED sinks. Once programmed through its I<sup>2</sup>C-compatible interface, the ADP5501 can run autonomously. An interrupt line (INT) is available to alert an external microprocessor of the status of its ambient light sensor comparator states, current limit, thermal overload, and overvoltage conditions.

### BACKLIGHT DRIVE CONTROL

White LEDs are common in backlighting the displays of modern portable devices such as cell phones. White LEDs require a high forward voltage,  $V_F$  (typically, 3.5 V), before they conduct current and emit light. Display panels, depending on their size, can be backlit with single or multiple white LEDs. In panels that require multiple LEDs, the LEDs are commonly connected in a series string to achieve uniform brightness in each LED by passing a common current through all of them. The LED string, however, needs to be biased with a voltage greater than the sum of each LED  $V_F$  before it can conduct.

To achieve this high voltage, the ADP5501 contains a nonsynchronous boost device capable of driving an LED string with an OVP limited to 24.5 V (minimum). For detailed information about the boost device, see the Applications Information section. With sufficient forward voltage created, the ADP5501 controls the current (and thus the brightness) of the LED string via an adjustable internal current sink. An internal state machine, in conjunction with programmable timers, dynamically adjusts the current sink between 0 mA and 30 mA to achieve impressive backlight control features.

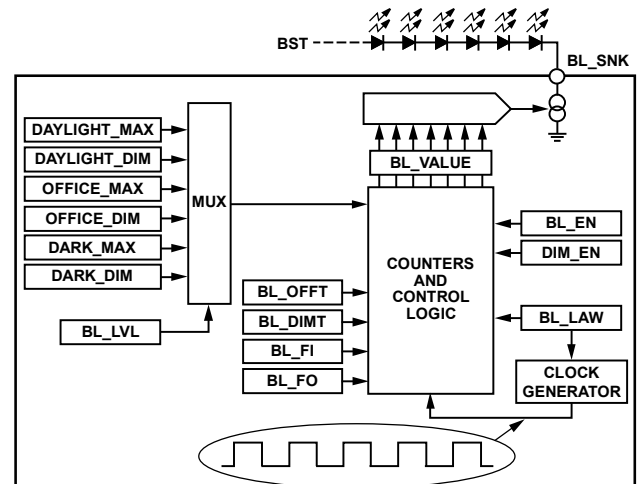

Figure 14. Backlight Brightness Control

## BACKLIGHT OPERATING LEVELS

Backlight brightness control can operate in three distinct levels: daylight (L1), office (L2), and dark (L3). The BL\_LVL bits in Register 0x02 control the level at which the backlight operates. The BL\_LVL bits can be changed manually or, if in auto mode, by the ambient light sensor (see the Ambient Light Sensing section). By default, the backlight operates at daylight level (BL\_LVL = 00), where the maximum brightness is set using Register 0x05 (DAYLIGHT\_MAX). A daylight dim setting can also be set using Register 0x06 (DAYLIGHT\_DIM). When operating at office level (BL\_LVL = 01), the backlight maximum and dim brightness settings are set by Register 0x07 (OFFICE\_MAX) and Register 0x08 (OFFICE\_DIM). When operating at dark level (BL\_LVL = 10), the backlight maximum and dim brightness settings are set by Register 0x09 (DARK\_MAX) and Register 0x0A (DARK\_DIM).

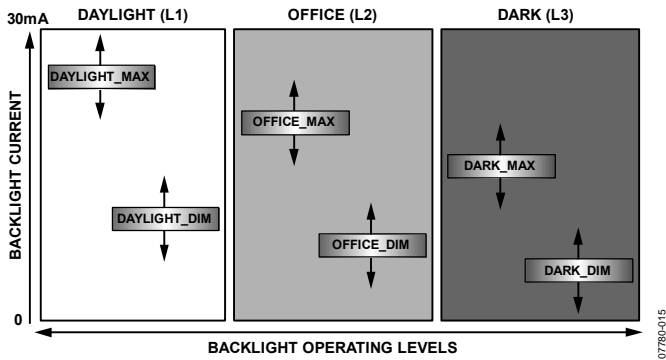

Figure 15. Backlight Operating Levels

## BACKLIGHT MAXIMUM AND DIM SETTINGS

The backlight maximum and dim current settings are determined by a 7-bit code programmed by the user into the registers listed in the Backlight Operating Levels section. This 7-bit code allows the user to set the backlight to one of 128 different levels between 0 mA and 30 mA. The ADP5501 can implement two distinct algorithms to achieve a linear and a nonlinear relationship between input code and backlight current. The BL\_LAW bits, in Register 0x02, are used to swap between algorithms.

By default, the ADP5501 uses a linear algorithm (BL\_LAW = 00), where the backlight current increases linearly for a corresponding increase of input code. Backlight current, in milliamperes (mA), is determined by the following equation:

$$\text{Backlight Current} = \text{Code} \times (\text{Fullscale\_Current}/127) \quad (1)$$

where:

*Code* is the input code programmed by the user.

*Fullscale\_Current* is the maximum sink current allowed (typically, 30 mA).

The ADP5501 can also implement a nonlinear (square approximation) relationship between input code and backlight current level. In this case (BL\_LAW = 01), the backlight current, in milliamperes (mA), is determined by the following equation:

$$\text{Backlight Current} = \left( \text{Code} \times \frac{\sqrt{\text{Fullscale\_Current}}}{127} \right)^2 \quad (2)$$

Figure 16 shows the backlight current level vs. input code for both the linear and square law algorithms.

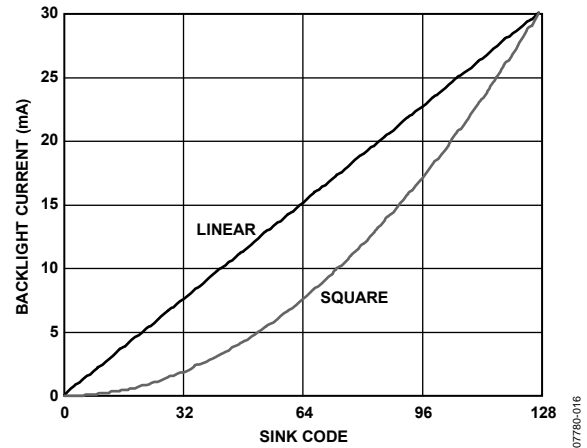

Figure 16. Backlight Current vs. Sink Code

## BACKLIGHT TURN-ON/TURN-OFF/DIM

With the device in normal mode (set in Register 0x00 by STNBY = 1), the backlight can be turned on using the BL\_EN bit in Register 0x00. Before turning on the backlight, the user should choose the level (daylight (L1), office (L2), or dark (L3)) to operate in and ensure that maximum and dim settings are programmed for that level. The backlight turns on when BL\_EN = 1. The backlight turns off when BL\_EN = 0.

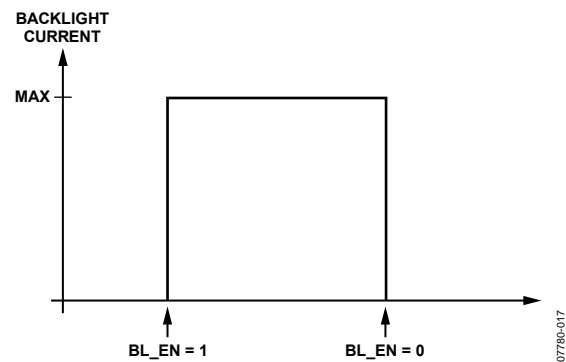

Figure 17. Backlight Turn-On/Turn-Off

While the backlight is on (BL\_EN = 1), the user can change it to a dim setting by programming DIM\_EN = 1 in Register 0x00. If DIM\_EN = 0, the backlight reverts to its maximum setting.

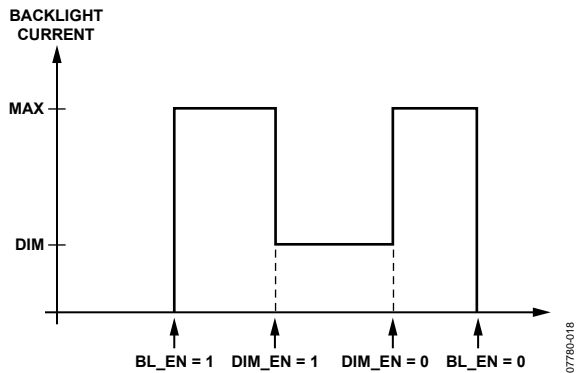

Figure 18. Backlight Turn-On/Turn-Off/Dim

The maximum and dim settings can be set between 0 mA and 30 mA; therefore, it is possible to program a dim setting that is greater than a maximum setting. For normal expected operation, the user should program the dim setting to less than the maximum setting.

**AUTOMATIC DIM AND TURN-OFF TIMERS**

The user can program the backlight to dim automatically by using the BL\_DIMT timer in Register 0x03. The dim timer has 15 settings ranging from 10 sec to 2 min. The user should program the dim timer before turning on the backlight. If BL\_EN = 1, the backlight turns on to its maximum setting, and the dim timer starts counting. When the dim timer expires, the internal state machine sets DIM\_EN = 1, and the backlight goes to its dim setting.

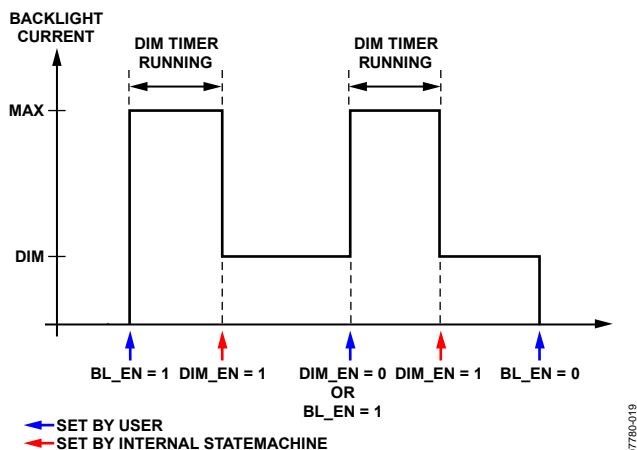

Figure 19. Dim Timer

If the user clears the DIM\_EN bit (or reasserts the BL\_EN bit), the backlight reverts to its maximum setting, and the dim timer begins counting again. When the dim timer expires, the internal state machine again sets DIM\_EN = 1, and the backlight goes to its dim setting. Reasserting BL\_EN at any point during the dim timer countdown causes the timer to reset and begin counting again. The backlight can be turned off at any point during the dim timer countdown by clearing BL\_EN.

The user can also program the backlight to turn off automatically by using the BL\_OFFT timer in Register 0x03. The off timer has 15 settings ranging from 10 sec to 2 min. The user should

program the off timer before turning on the backlight. If BL\_EN = 1, the backlight turns on to its maximum setting, and the off timer starts counting. When the off timer expires, the internal state machine clears the BL\_EN bit, and the backlight turns off.

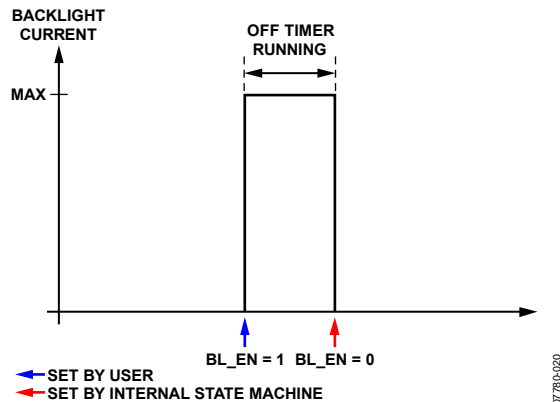

Figure 20. Off Time

Reasserting BL\_EN at any point during the off timer count-down causes the timer to reset and begin counting again. The backlight can be turned off at any point during the off timer countdown by clearing BL\_EN.

The dim timer and off timer can be used together for sequential maximum-to-dim-to-off functionality. With both the dim and off timers programmed, if BL\_EN is asserted, the backlight turns on to its maximum setting. When the dim timer expires, the backlight changes to its dim setting. When the off timer expires, the backlight turns off.

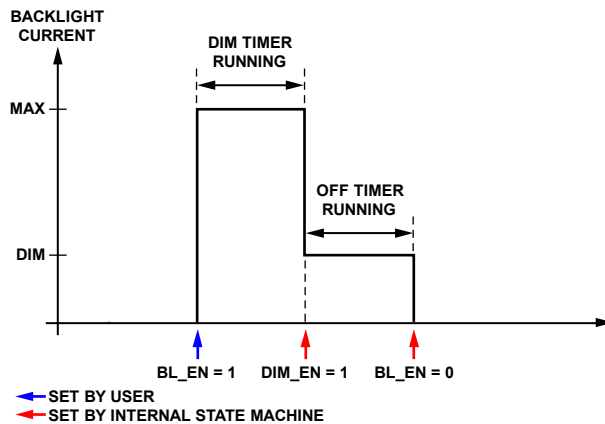

Figure 21. Dim and Off Timers Used Together

**LINEAR BACKLIGHT FADE-IN AND FADE-OUT**

To counteract the abrupt effect on the eyes of near instant turn-on and turn-off of the backlight, the ADP5501 contains timers to facilitate smooth fading among the off, on, and dim states. By default (BL\_LAW = 00 in Register 0x02), the ADP5501 implements a fading scheme using the linear backlight code algorithm (see Equation 1).

# ADP5501

The BL\_FI timer in Register 0x04 can be used for smooth fade-in transitions from low to high backlight settings such as off to dim, off to maximum, and dim to maximum. The BL\_FI timer can be programmed to one of 15 settings ranging from 0.3 sec to 5.5 sec. The BL\_FI timer should be programmed before asserting BL\_EN.

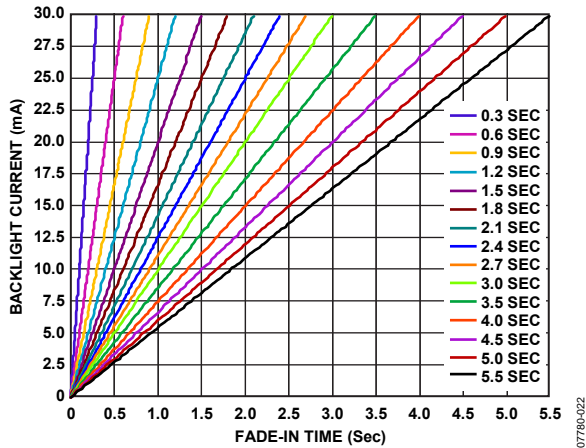

Figure 22. Linear Fade-In Times

The time programmed in BL\_FI represents the time it takes the backlight current to go from 0 mA to 30 mA. Fading between intermediate settings is shorter.

The BL\_FO timer in Register 0x04 can be used for smooth fade-out transitions from high to low backlight settings such as maximum to dim and dim to off. The BL\_FO timer can be programmed to one of 15 settings ranging from 0.3 sec to 5.5 sec. The BL\_FO timer should be programmed before asserting BL\_EN.

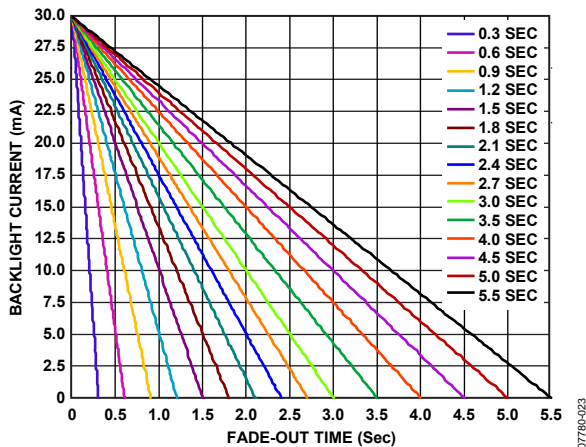

Figure 23. Linear Fade-Out Times

The time programmed in BL\_FO represents the time it takes the backlight current to go from 30 mA to 0 mA. Fading between intermediate settings is shorter.

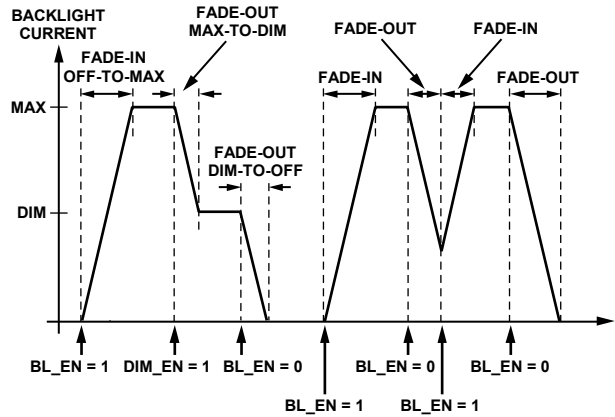

Figure 24. Backlight Turn-On/Turn-Off/Dim with Fade Timers

Figure 24 shows the fade timers in use. With BL\_FI and BL\_FO programmed, if BL\_EN is asserted, the backlight fades in to its maximum setting. If DIM\_EN is asserted, the backlight fades out to its dim setting. If BL\_EN is cleared, the backlight fades out to off.

During any point in a fade-out, if BL\_EN is asserted, the backlight stops at its current fade-out position and begins fading in.

The fade-in and fade-out timers can be used independently of each other; that is, fade-in can be enabled while fade-out is disabled. The fade timers can also be used with the off and dim timers.

Figure 25 shows the fade timers used with the dim and off timers.

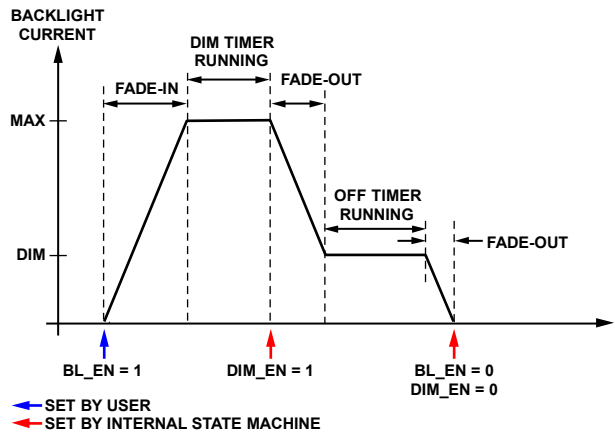

Figure 25. Fade/Dim/Off Timers Used Together

### FADE OVERRIDE

A fade override feature allows the BL\_FI and BL\_FO timers to be overridden when the BL\_EN bit is reasserted (by the user setting the FOVR bit in Register 0x02) during a fade-in or fade-out period and to set the backlight to its maximum setting.

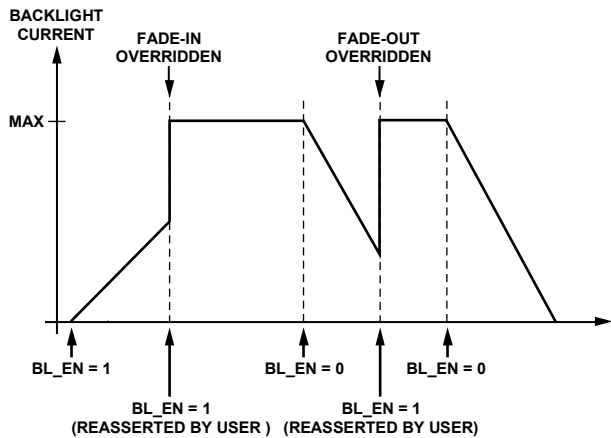

Figure 26. Fade Override

### ADVANCED FADING (SQUARE)

Although the default linear fade algorithm gives a smooth increase and decrease in backlight current, the resulting increase and decrease in brightness still appear visually abrupt. For example, for a given fade-in time, the eye notices an initial increase in brightness as backlight current is increased but cannot perceive much more increase in brightness as backlight current is increased to maximum.

The reason for this is that the eye perceives changes in light when the brightness of the light source is changed logarithmically (Weber-Fechner law). To provide a more natural fading experience to the user, the fade timers can be used in conjunction with the square law approximation backlight codes (see Equation 2) by setting BL\_LAW = 01 in Register 0x02.

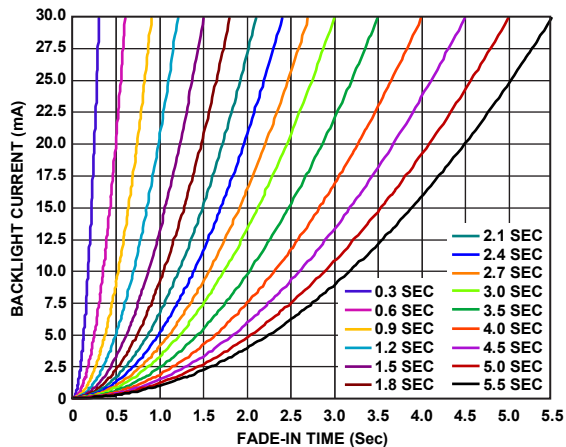

Figure 27. Square Law Fade-In Times

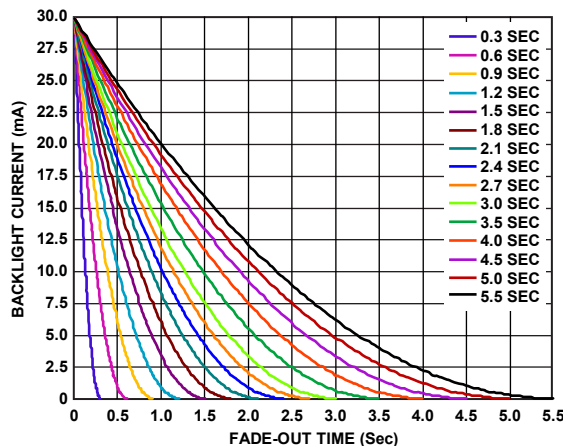

Figure 28. Square Law Fade-Out Times

### ADVANCED FADING (CUBIC 1 AND CUBIC 2)

Two additional advanced settings in Register 0x02 are available for fading the backlight brightness levels, Cubic 1 (BL\_LAW = 10) and Cubic 2 (BL\_LAW = 11). As shown in the backlight brightness control block diagram in Figure 14, linear fading and square fading are implemented by ramping the 128 linear/square algorithm codes at a fixed frequency over the duration of a given fade-in/fade-out time.

Cubic fading is implemented by re-using the square algorithm codes but ramping them with a clock source whose frequency output increases as the sink current code increases (see Figure 29). Cubic 1 and Cubic 2 have different frequency vs. code characteristics.

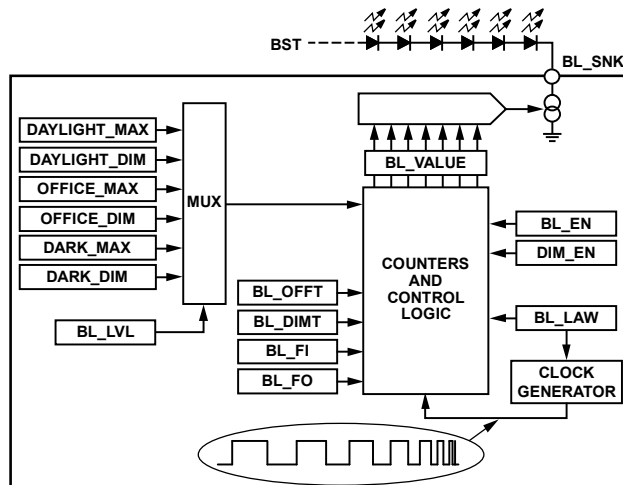

Figure 29. Backlight Brightness Control (Cubic)

# ADP5501

Figure 30 shows a comparison of fading techniques. Cubic fades complete faster than linear or square fades for a given fade time setting. Cubic 1 completes approximately 30% faster, and Cubic 2 completes approximately 10% faster, than an equivalent linear or square fade time.

With four fade laws and 15 fade time settings, the user can easily find the right fade experience for an application.

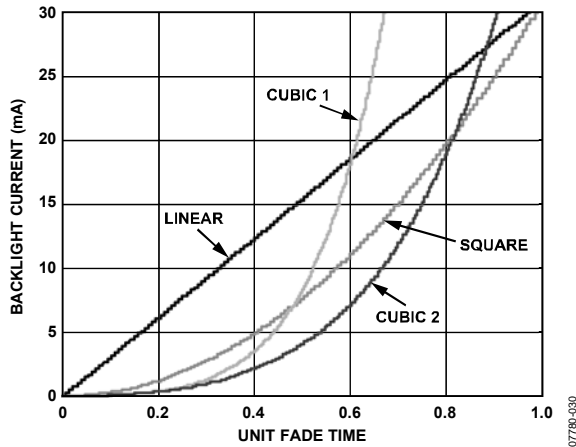

Figure 30. Fade Law Comparison over a Unit Fade Time

## AMBIENT LIGHT SENSING

The ADP5501 can be used in conjunction with an external photosensor to detect when ambient light conditions drop below programmable set points. An ADC samples the output of the external photosensor. The ADC result is fed into two programmable trip comparators. The ADC has an input range of 0  $\mu$ A to 1000  $\mu$ A (typical).

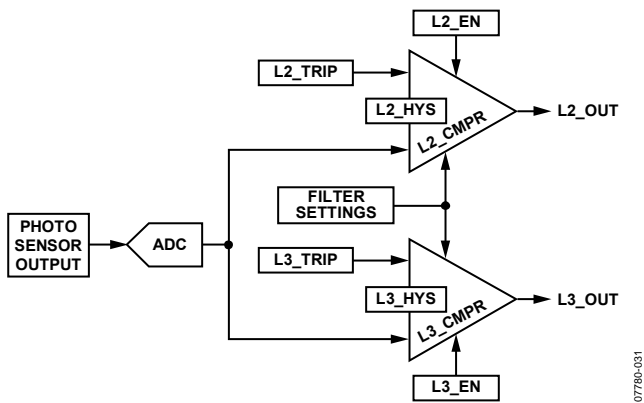

Figure 31. Ambient Light Sensing and Trip Comparators

The Level 2 (office) light sensor comparator, L2\_CMPR, is used to detect when the photosensor output drops below the programmable L2\_TRIP point. If this event occurs, the L2\_OUT status signal is set. L2\_CMPR contains programmable hysteresis, meaning that the photosensor output must rise above L2\_TRIP + L2\_HYS before L2\_OUT is cleared. L2\_CMPR is enabled in Register 0x0C via the L2\_EN bit. The L2\_TRIP and L2\_HYS values of L2\_CMPR can be set between 0  $\mu$ A and 1000  $\mu$ A in steps of 4  $\mu$ A (typical).

L3\_CMPR is used to detect when the photosensor output drops below the programmable L3\_TRIP point. If this event occurs, the L3\_OUT status signal is set. L3\_CMPR contains programmable hysteresis, meaning that the photosensor output must rise above L3\_TRIP + L3\_HYS before L3\_OUT is cleared. L3\_CMPR is enabled in Register 0x0C via the L3\_EN bit. The L3\_TRIP and L3\_HYS values of L3\_CMPR can be set between 0  $\mu$ A and 127  $\mu$ A in steps of 0.5  $\mu$ A (typical).

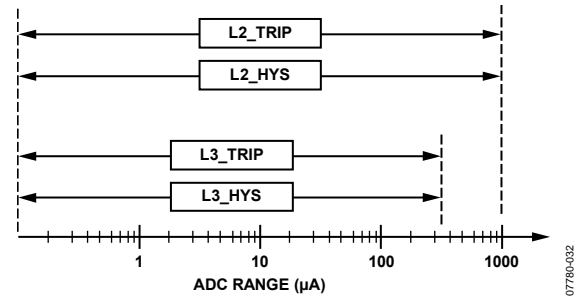

Figure 32. Comparator Ranges

The L2\_CMPR and L3\_CMPR comparators can be enabled independently of each other. The ADC and comparators run continuously when L2\_EN and/or L3\_EN is set during automatic backlight adjustment mode. A single conversion takes 80 ms (typical). Filter times of between 80 ms and 10 sec can be programmed for the comparators before they change state.

It is also possible to use the light sensor comparators in a single-shot mode. After the single-shot measurement is completed, the internal state machine clears the FORCE\_RD bit in Register 0x0C.

The interrupt flag CMPR\_INT is set in Register 0x00 if either of the L2\_OUT or L3\_OUT status bits changes state, meaning that interrupts can be generated if ambient light conditions transition between any of the programmed trip points. CMPR\_INT can cause the INT pin to be asserted if the CMPR\_IEN bit is set in Register 0x01. The CMPR\_INT flag can be cleared only by writing a 1 to it.

## AUTOMATIC BACKLIGHT ADJUSTMENT

The ambient light sensor comparators can be used to automatically transition the backlight among its three operating levels. To enable this mode, the BL\_AUTO\_ADJ bit is set in Register 0x02.

Once enabled, the internal state machine takes control of the BL\_LVL bits in Register 0x02 and changes them based on the L2\_OUT and L3\_OUT status bits in Register 0x0C. The L2\_OUT status bit indicates that ambient light conditions have dropped below the L2\_TRIP point and the backlight should be moved to its office (L2) level. The L3\_OUT status bit indicates that ambient light conditions have dropped below the L3\_TRIP point and the backlight should be moved to its dark (L3) level. Table 5 shows the relationship between backlight operation and the ambient light sensor comparator outputs.

Table 5. Comparator Output Truth Table

BL_AUTO_ADJ	L3_OUT	L2_OUT	Backlight Operation
0	X <sup>1</sup>	X <sup>1</sup>	BL_LVL can be manually set by the user.
1	0	0	BL_LVL = 00; backlight operates at L1 (daylight).
1	0	1	BL_LVL = 01; backlight operates at L2 (office).
1	1	0	BL_LVL = 10; backlight operates at L3 (dark).
1	1	1	BL_LVL = 10; backlight operates at L3 (dark).

<sup>1</sup> X = don't care.

The L3\_OUT status bit has greater priority; therefore, the backlight operates at L3 (dark) even if L2\_OUT is set.

**LED CURRENT SINKS**

The ADP5501 has three additional current sinks that can be used as RGBs or auxiliary LED current sinks. Each current sink is programmable up to 14 mA (typical) and can be independently turned on and off.

The LED0 pin is the current sink for LED0. Its sink current can be set using LED0\_CURRENT in Register 0x14. LED0 sink can be enabled with LED0\_EN in Register 0x11.

The LED1 pin is the current sink for LED1. Its sink current can be set using LED1\_CURRENT in Register 0x15. LED1 sink can be enabled with LED1\_EN in Register 0x11.

The LED2 pin is the current sink for LED2. Its sink current can be set using LED2\_CURRENT in Register 0x16. LED2 sink can be enabled with LED2\_EN in Register 0x11.

These LEDx\_CURRENT registers are six bits wide, allowing the user to set the LED sink current to one of 64 different levels between 0 mA and 14 mA. The ADP5501 can implement two distinct algorithms to achieve a linear and a nonlinear relationship between input code and sink current.

By default, the ADP5501 uses a linear algorithm (LED\_LAW = 0 in Register 0x11), where the LED sink current increases linearly for a corresponding increase of input code. The LED sink current, in milliamperes (mA), is determined by the following equation:

$$LED\ Sink\ Current = Code \times (Fullscale\_Current/63) \quad (3)$$

where:

Code is the input code programmed by the user.

Fullscale\_Current is the maximum sink current allowed (typically, 14 mA).

The ADP5501 can also implement a nonlinear (square approximation) relationship between input code and LED sink current level. In this case (LED\_LAW = 1 in Register 0x11), the LED sink current, in milliamperes (mA), is determined by the following equation:

$$LED\ Sink\ Current = \left( Code \times \frac{\sqrt{Fullscale\_Current}}{63} \right)^2 \quad (4)$$

Figure 33 shows the backlight current level vs. the input code for both the linear and square law algorithms.

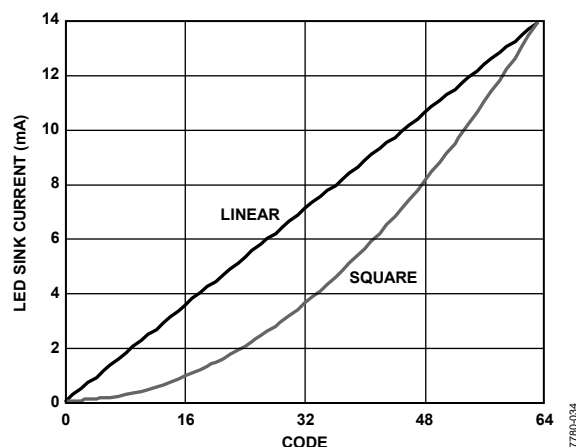

Figure 33. LED Sink Current vs. Code

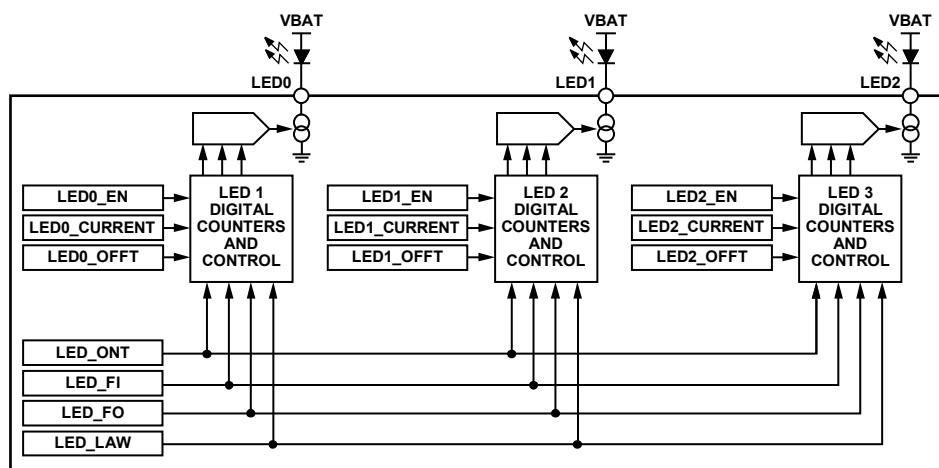

Figure 34. Status LED Current Sink



# ADP5501

Similar to the backlight current sink, the ADP5501 contains timers to facilitate the smooth fading between off and on states of the LED current sinks. All three LED sinks share a common fade-in (LED\_FI) timer as well as a common fade-out (LED\_FO) timer. The fade-in and fade-out timers are located in Register 0x13 and can be programmed to one of 15 settings ranging from 0.3 sec to 5.5 sec. Fade-in times represent the time it takes to fade from 0 mA to 14 mA. Fade-out times represent the time it takes to fade from 14 mA to 0 mA. Fading between intermediate settings is shorter. The fade timers should be programmed before asserting LEDx\_EN in Register 0x11.

By default (LED\_LAW = 0 in Register 0x11), the ADP5501 implements a fading scheme using the linear algorithm (see Equation 3).

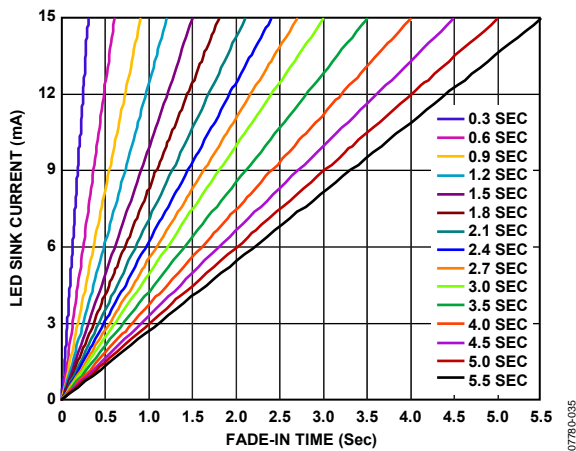

Figure 35. Linear Fade-In Times

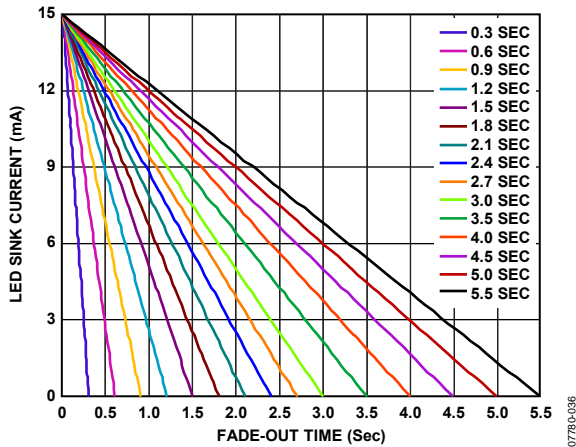

Figure 36. Linear Fade-Out Times

To provide a more natural fading experience for the user, the fade timers can be used in conjunction with the square law approximation codes (see Equation 4) by setting LED\_LAW = 1.

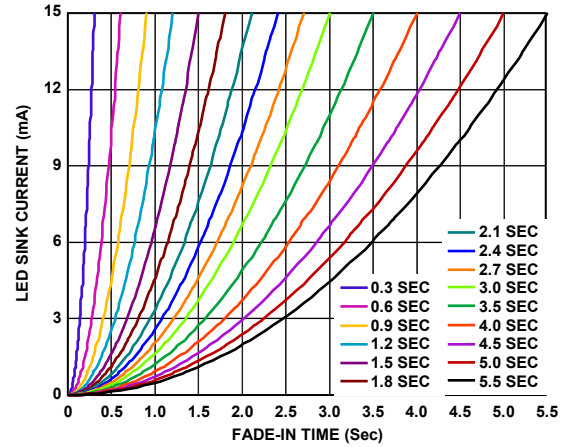

Figure 37. Square Law Fade-In Times

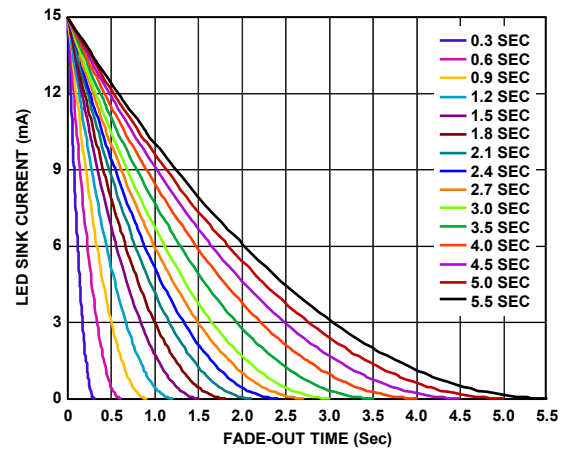

Figure 38. Square Law Fade-Out Times

The LED current sinks have additional timers to facilitate blinking functions. A shared on timer (LED\_ONT in Register 0x12) used in conjunction with three off timers (LED0\_OFFT, LED1\_OFFT, and LED2\_OFFT) allows the LED current sinks to be configured in various blinking modes. The on timer can be set to four different settings: 0.2 sec, 0.6 sec, 0.8 sec, and 1.2 sec. The off timers also have four different settings: disabled, 0.6 sec, 0.8 sec, and 1.2 sec. Blink mode is activated by setting the off timers to any setting other than disabled.

All fade-on and fade-off timers should be programmed before enabling any of the LED current sinks. If LEDx is on during a blink cycle and LEDx\_EN is cleared, LEDx goes off (or fades to off if fade-out is enabled). If LEDx is off during a blink cycle and LEDx\_EN is cleared, LEDx stays off.



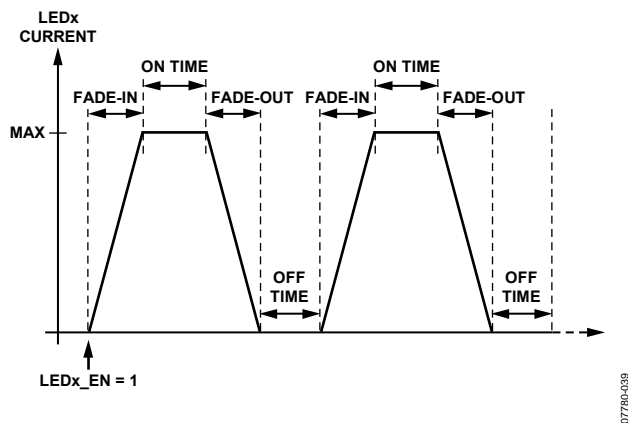
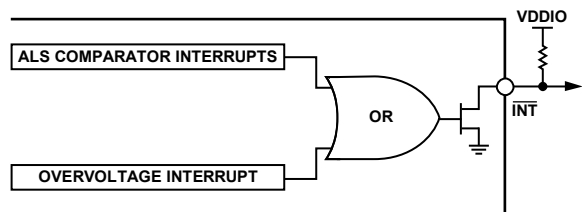

Figure 39. LEDx Blink Mode with Fading

### INTERRUPT OUTPUT ( $\overline{\text{INT}}$ )

The ADP5501 can generate interrupts to an external processor via its interrupt output,  $\overline{\text{INT}}$ .  $\overline{\text{INT}}$  is an active low, open-drain pin that should be pulled up to VDDIO.  $\overline{\text{INT}}$  can be asserted by one of several internal blocks, as shown in Figure 40.

Figure 40.  $\overline{\text{INT}}$  Pin Drive

### RESET INPUT ( $\overline{\text{RST}}$ )

The ADP5501 can be restored to a power-on reset state if the  $\overline{\text{RST}}$  pin is held low.  $\overline{\text{RST}}$  contains a debounce circuit; therefore, the pin must be held low for greater than 75  $\mu\text{s}$  (typical) before a reset occurs.

## COMMUNICATON INTERFACE

Communication with the ADP5501 is done via its I<sup>2</sup>C-compatible serial interface. Figure 41 shows a typical write sequence for programming an internal register.

1. The cycle begins with a start condition, followed by the chip write address (0x64).
2. The ADP5501 acknowledges the chip write address byte by pulling the data line low.
3. The address of the register to which data is to be written is sent next.
4. The ADP5501 acknowledges the register address byte by pulling the data line low.
5. The data byte to be written to is sent next.
6. The ADP5501 acknowledges the data byte by pulling the data line low.
7. A stop condition completes the sequence.

Figure 42 shows a typical read sequence for reading back an internal register.

1. The cycle begins with a start condition, followed by the chip write address (0x64).
2. The ADP5501 acknowledges the chip write address byte by pulling the data line low.
3. The address of the register from which data is to be read is sent next.
4. The ADP5501 acknowledges the register address byte by pulling the data line low.
5. The cycle continues with a repeat start, followed by the chip read address (0x65).
6. The ADP5501 acknowledges the chip read address byte by pulling the data line low.
7. The ADP5501 places the contents of the previously addressed register on the bus for readback.
8. There is a no acknowledge following the readback data byte, and the cycle is completed with a stop condition.

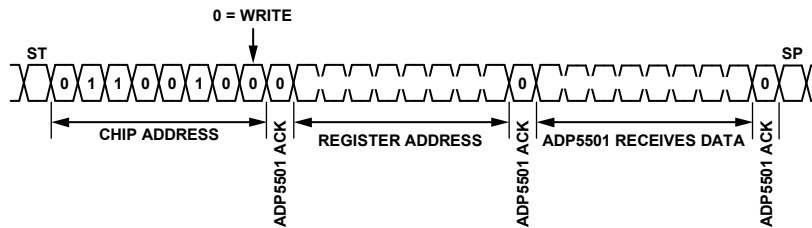

Figure 41. I<sup>2</sup>C Write Sequence

07780-041

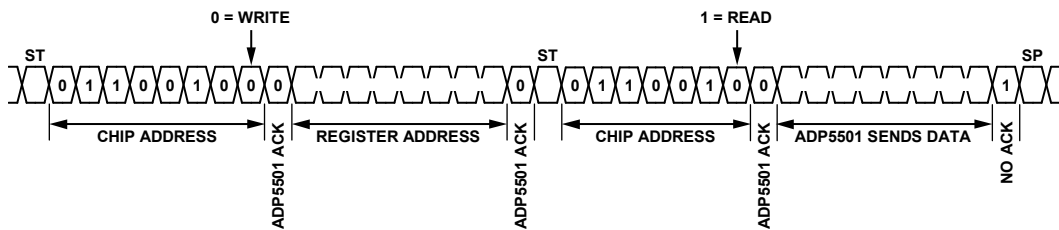

Figure 42. I<sup>2</sup>C Read Sequence

07780-042

## REGISTER MAP

All registers are 0 on reset. Unused bits are read as 0.

Table 6.

Register Address	Register Name	Register Description
0x00	MODE_STATUS	Sets the device operating mode; contains enables for backlight on/dim and top level interrupt status bits.
0x01	INTERRUPT_ENABLE	Contains enables for allowing interrupts to assert $\overline{INT}$ .
0x02	BL_CONTROL	Sets parameters relating to backlight control.
0x03	BL_TIME	Contains backlight off and dim timers.
0x04	BL_FADE	Contains backlight fade-in and fade-out timers.
0x05	DAYLIGHT_MAX	Sets the daylight (L1) maximum current.
0x06	DAYLIGHT_DIM	Sets the daylight (L1) dim current.
0x07	OFFICE_MAX	Sets the office (L2) maximum current.
0x08	OFFICE_DIM	Sets the office (L2) dim current.
0x09	DARK_MAX	Sets the dark (L3) maximum current.
0x0A	DARK_DIM	Sets the dark (L3) dim current.
0x0B	BL_VALUE	Read-only register of what the backlight is presently set to.
0x0C	ALS_CMPR_CFG	Sets enables and filters for ambient light sensor comparators; contains comparator output status bits.
0x0D	L2_TRIP	Sets the light sensor comparator (L2_CMPR) threshold point.
0x0E	L2_HYS	Sets the light sensor comparator (L2_CMPR) hysteresis.
0x0F	L3_TRIP	Sets the light sensor comparator (L3_CMPR) threshold point.
0x10	L3_HYS	Sets the light sensor comparator (L3_CMPR) hysteresis.
0x11	LED_SINK_CONTROL	Contains enables and configuration for the LED current sinks.
0x12	LED_TIME	Contains the on and off timers for the status LED current sinks.
0x13	LED_FADE	Contains the fade-in and fade-out timers for the status LED current sinks.
0x14	LED0_CURRENT	Sets the LED0 sink current.
0x15	LED1_CURRENT	Sets the LED1 sink current.
0x16	LED2_CURRENT	Sets the LED2 sink current.

## DETAILED REGISTER DESCRIPTIONS

**Table 7. Register 0x00, Device Mode and Status (MODE\_STATUS)**

Bit	Name	R/W	Description
7	STNBY	R/W	0 = the device is in standby mode. (If $1.8V \leq VDDIO \leq 2.7V$ , then I <sup>2</sup> C.) 1 = the device is in operating mode. Additional functions such as backlight driver, LED sinks, and ambient light sensor functions can be enabled.
6	BL_EN	R/W	0 = the backlight driver is disabled. 1 = the backlight driver is enabled.
5	DIM_EN	R/W	0 = dim mode is disabled. 1 = dim mode is enabled. Dim mode can be enabled in two ways. One is by manually setting this bit, in which case, the backlight stays at a dim level until this bit is manually cleared. The second method is by setting the DIMT timer, in which case, an internal state machine sets this bit and clears it when the timer expires.
4 <sup>1</sup>	OVP_INT	R/W	0 = no overvoltage protection (OVP) condition. 1 = OVP condition detected. Once set, this bit can be cleared by writing a 1 to it.
3 <sup>1</sup>	CMPR_INT	R/W	0 = no ambient light sensor comparators have triggered. 1 = one of the ambient light sensor comparators has triggered. Once set, this bit can be cleared by writing a 1 to it.
2 to 0	Not used		

<sup>1</sup> If one of the interrupt bits is cleared and there is a pending interrupt,  $\overline{INT}$  deasserts for 50  $\mu$ s and reasserts, but the status of the pending interrupt stays set.

**Table 8. Register 0x01, Interrupt Enable (INTERRUPT\_ENABLE)**

Bit	Name	R/W	Description
7 to 5	Not used		
4	AUTO_LD_EN	R/W	0 = autoloading is disabled. 1 = autoloading is enabled. A 1 mA dummy load turns on when the backlight code is less than 8 (linear law) or less than Code 32 (square law).
3	CMPR_IEN	R/W	0 = ambient light sensor comparator(s) interrupt is disabled. 1 = ambient light sensor comparator(s) interrupt is enabled.
2	OVP_IEN	R/W	0 = OVP interrupt is disabled. 1 = OVP interrupt is enabled.
1 to 0	Not used		

**Table 9. Register 0x02, Backlight Control (BL\_CONTROL)**

Bit	Name	R/W	Description
7 to 6	BL_LVL	R/W	Brightness level control for the backlight. 00 = daylight (L1). 01 = office (L2). 10 = dark (L3). See the description for the BL_AUTO_ADJ bit.
5 to 4	BL_LAW	R/W	Backlight fade-on/fade-off transfer characteristic. 00 = linear. 01 = square. 10 = Cubic 1. 11 = Cubic 2.

Bit	Name	R/W	Description
3	BL_AUTO_ADJ	R/W	0 = ambient light sensor comparators have no effect on the backlight operating level. The user can manually adjust the backlight operating level using the BL_LVL bits. 1 = ambient light sensor comparators automatically adjust the backlight operating level. The internal state machine takes control of the BL_LVL bits.
2	OVP_EN	R/W	0 = soft OVP protection disabled. 1 = soft OVP protection enabled.
1	FOVR	R/W	0 = backlight fade override is disabled. 1 = backlight fade override is enabled.
0	Not used		

**Table 10. Register 0x03, Backlight Off and Dim Timers (BL\_TIME)**

Bit	Name	R/W	Description
7 to 4	BL_OFFT	R/W	Backlight off timer; the timer should be set before BL_EN is set. 0000 = the timer is disabled. 0001 = 10 sec. 0010 = 15 sec. 0011 = 20 sec. 0100 = 25 sec. 0101 = 30 sec. 0110 = 35 sec. 0111 = 40 sec. 1000 = 50 sec. 1001 = 60 sec. 1010 = 70 sec. 1011 = 80 sec. 1100 = 90 sec. 1101 = 100 sec. 1110 = 110 sec. 1111 = 120 sec.
3 to 0	BL_DIMT	R/W	Backlight dim timer; the timer should be set before BL_EN is set. 0000 = the timer is disabled. 0001 = 10 sec. 0010 = 15 sec. 0011 = 20 sec. 0100 = 25 sec. 0101 = 30 sec. 0110 = 35 sec. 0111 = 40 sec. 1000 = 50 sec. 1001 = 60 sec. 1010 = 70 sec. 1011 = 80 sec. 1100 = 90 sec. 1101 = 100 sec. 1110 = 110 sec. 1111 = 120 sec.

# ADP5501

**Table 11. Register 0x04, Backlight Fade-In and Fade-Out Timers (BL\_FADE)**

Bit	Name	R/W	Description
7 to 4	BL_FO	R/W	Backlight fade-out timer; the timer should be set before BL_EN is set. 0000 = the timer is disabled. 0001 = 0.3 sec. 0010 = 0.6 sec. 0011 = 0.9 sec. 0100 = 1.2 sec. 0101 = 1.5 sec. 0110 = 1.8 sec. 0111 = 2.1 sec. 1000 = 2.4 sec. 1001 = 2.7 sec. 1010 = 3.0 sec. 1011 = 3.5 sec. 1100 = 4.0 sec. 1101 = 4.5 sec. 1110 = 5.0 sec. 1111 = 5.5 sec.
3 to 0	BL_FI	R/W	Backlight fade-in timer; the timer should be set before BL_EN is set. 0000 = the timer is disabled. 0001 = 0.3 sec. 0010 = 0.6 sec. 0011 = 0.9 sec. 0100 = 1.2 sec. 0101 = 1.5 sec. 0110 = 1.8 sec. 0111 = 2.1 sec. 1000 = 2.4 sec. 1001 = 2.7 sec. 1010 = 3.0 sec. 1011 = 3.5 sec. 1100 = 4.0 sec. 1101 = 4.5 sec. 1110 = 5.0 sec. 1111 = 5.5 sec.

**Table 12. Register 0x05, Level 1 (Daylight) Maximum Current (DAYLIGHT\_MAX)**

Bit	Name	R/W	Description
7	Not used		
6 to 0	DAYLIGHT_MAX	R/W	Maximum current setting for the backlight when BL_LVL is at Level 1 (daylight). See Figure 16 for the backlight current vs. sink code relationship.

**Table 13. Register 0x06, Level 1 (Daylight) Dim Current (DAYLIGHT\_DIM)**

Bit	Name	R/W	Description
7	Not used		
6 to 0	DAYLIGHT_DIM	R/W	Dim current setting for the backlight when BL_LVL is at Level 1 (daylight). See Figure 16 for the backlight current vs. sink code relationship.

**Table 14. Register 0x07, Level 2 (Office) Maximum Current (OFFICE\_MAX)**

Bit	Name	R/W	Description
7	Not used		
6 to 0	OFFICE_MAX	R/W	Maximum current setting for the backlight when BL_LVL is at Level 2 (office). See Figure 16 for the backlight current vs. sink code relationship.

**Table 15. Register 0x08, Level 2 (Office) Dim Current (OFFICE\_DIM)**

Bit	Name	R/W	Description
7	Not used		
6 to 0	OFFICE_DIM	R/W	Dim current setting for the backlight when BL_LVL is at Level 2 (office). See Figure 16 for the backlight current vs. sink code relationship.

**Table 16. Register 0x09, Level 3 (Dark) Maximum Current (DARK\_MAX)**

Bit	Name	R/W	Description
7	Not used		
6 to 0	DARK_MAX	R/W	Maximum current setting for the backlight when BL_LVL is at Level 3 (dark). See Figure 16 for the backlight current vs. sink code relationship.

**Table 17. Register 0x0A, Level 3 (Dark) Dim Current (DARK\_DIM)**

Bit	Name	R/W	Description
7	Not used		
6 to 0	DARK_DIM	R/W	Dim current setting for the backlight when BL_LVL is at Level 3 (dark). See Figure 16 for the backlight current vs. sink code relationship.

**Table 18. Register 0x0B, Backlight Current Value (BL\_VALUE)**

Bit	Name	R/W	Description
7	Not used		
6 to 0	BL_VALUE	R	Read-only register that contains the present value to which the backlight is programmed.

**Table 19. Register 0x0C, Light Sensor Comparator Configuration (ALS\_CMPR\_CFG)**

Bit	Name	R/W	Description
7 to 5	FILT	R/W	Light sensor filter time. 000 = 0.08 sec. 001 = 0.16 sec. 010 = 0.32 sec. 011 = 0.64 sec. 100 = 1.28 sec. 101 = 2.56 sec. 110 = 5.12 sec. 111 = 10.24 sec.
4	FORCE_RD	R/W	Forces the light sensor comparator to perform a single conversion. This bit is cleared by the internal state machine once the conversion is complete.
3	L3_OUT	R	0 = ambient light is greater than Level 3 (dark). 1 = the light sensor comparator has detected a change in ambient light from Level 2 (office) to Level 3 (dark).
2	L2_OUT	R	0 = ambient light is greater than Level 2 (office). 1 = the light sensor comparator has detected a change in ambient light from Level 1 (daylight) to Level 2 (office).
1	L3_EN	R/W	0 = disable Comparator L3_CMPR. 1 = enable Comparator L3_CMPR. If automatic backlight adjustment is required, BL_AUTO_ADJ must be set also.
0	L2_EN	R/W	0 = disable Comparator L2_CMPR. 1 = enable Comparator L2_CMPR. If automatic backlight adjustment is required, BL_AUTO_ADJ must be set also.

**Table 20. Register 0x0D, Level 2 (Office) Comparator Trip Point (L2\_TRIP)**

Bit	Name	R/W	Description
6 to 0	L2_TRIP	R/W	Sets the trip value for Comparator L2_CMPR. If ambient light levels fall below this trip point, L2_OUT is set. Each code is equal to 4 $\mu$ A (typical). Full scale is 1000 $\mu$ A (typical).

# ADP5501

**Table 21. Register 0x0E, Level 2 (Office) Comparator Hysteresis (L2\_HYS)**

Bit	Name	R/W	Description
6 to 0	L2_HYS	R/W	Sets the hysteresis value for Comparator L2_CMPR. If ambient light levels increase above L2_TRIP + L2_HYS, L2_OUT is cleared. Each code is equal to 4 $\mu$ A (typical). Full scale is 1000 $\mu$ A (typical).

**Table 22. Register 0x0F, Level 3 (Dark) Comparator Trip Point (L3\_TRIP)**

Bit	Name	R/W	Description
6 to 0	L3_TRIP	R/W	Sets the trip value for Comparator L3_CMPR. If ambient light levels fall below this trip point, L3_OUT is set. Each code is equal to 0.5 $\mu$ A (typical). Full scale is 127 $\mu$ A (typical).

**Table 23. Register 0x10, Level 3 (Dark) Comparator Hysteresis (L3\_HYS)**

Bit	Name	R/W	Description
6 to 0	L3_HYS	R/W	Sets the hysteresis value for Comparator L3_CMPR. If ambient light levels increase above L3_TRIP + L3_HYS, L3_OUT is cleared. Each code is equal to 0.5 $\mu$ A (typical). Full scale is 127 $\mu$ A (typical).

**Table 24. Register 0x11, LED Control (LED\_SINK\_CONTROL)**

Bit	Name	R/W	Description
7 to 4	Not used		
3	LED_LAW	R/W	LED current sink fade-on/fade-off transfer characteristic. 0 = linear. 1 = square.
2	LED2_EN	R/W	0 = LED2 sink is disabled. 1 = LED2 sink is enabled.
1	LED1_EN	R/W	0 = LED1 sink is disabled. 1 = LED1 sink is enabled.
0	LED0_EN	R/W	0 = LED0 sink is disabled. 1 = LED0 sink is enabled.

**Table 25. Register 0x12, LED On and Off Timers (LED\_TIME)**

Bit	Name	R/W	Description
7 to 6	LED_ONT	R/W	Sets the LED on time when used in conjunction with the LEDx_OFFT timer to perform LED blinking. All three LED sinks share this common timer. 00 = 0.2 sec. 01 = 0.6 sec. 10 = 0.8 sec. 11 = 1.2 sec.
5 to 4	LED2_OFFT	R/W	Sets the LED2 off time when used in conjunction with the LED_ONT timer to perform LED blinking. LED2 stays on continuously if the timer is disabled. 00 = LED2 timer is disabled. 01 = 0.6 sec. 10 = 0.8 sec. 11 = 1.2 sec.
3 to 2	LED1_OFFT	R/W	Sets the LED1 off time when used in conjunction with the LED_ONT timer to perform LED blinking. LED1 stays on continuously if the timer is disabled. 00 = LED1 timer is disabled. 01 = 0.6 sec. 10 = 0.8 sec. 11 = 1.2 sec.
1 to 0	LED0_OFFT	R/W	Sets the LED0 off time when used in conjunction with the LED_ONT timer to perform LED blinking. LED0 stays on continuously if the timer is disabled. 00 = LED0 timer is disabled. 01 = 0.6 sec. 10 = 0.8 sec. 11 = 1.2 sec.



Table 26. Register 0x13, LED Fade-In and Fade-Out Timers (LED\_FADE)

Bit	Name	R/W	Description
7 to 4	LED_FO	R/W	LED fade-out timer; the timer should be set before LEDx_EN is enabled. 0000 = the timer is disabled. 0001 = 0.3 sec. 0010 = 0.6 sec. 0011 = 0.9 sec. 0100 = 1.2 sec. 0101 = 1.5 sec. 0110 = 1.8 sec. 0111 = 2.1 sec. 1000 = 2.4 sec. 1001 = 2.7 sec. 1010 = 3.0 sec. 1011 = 3.5 sec. 1100 = 4.0 sec. 1101 = 4.5 sec. 1110 = 5.0 sec. 1111 = 5.5 sec.
3 to 0	LED_FI	R/W	LED fade-in timer; the timer should be set before LEDx_EN is enabled. 0000 = the timer is disabled. 0001 = 0.3 sec. 0010 = 0.6 sec. 0011 = 0.9 sec. 0100 = 1.2 sec. 0101 = 1.5 sec. 0110 = 1.8 sec. 0111 = 2.1 sec. 1000 = 2.4 sec. 1001 = 2.7 sec. 1010 = 3.0 sec. 1011 = 3.5 sec. 1100 = 4.0 sec. 1101 = 4.5 sec. 1110 = 5.0 sec. 1111 = 5.5 sec.

Table 27. Register 0x14, LED0 Sink Current (LED0\_CURRENT)

Bit	Name	R/W	Description
7 to 6	Not used		
5 to 0	LED0_CURRENT	R/W	Sink current setting for LED0. See Figure 33 for LED sink current vs. code relationship.

Table 28. Register 0x15, LED1 Sink Current (LED1\_CURRENT)

Bit	Name	R/W	Description
7 to 6	Not used		
5 to 0	LED1_CURRENT	R/W	Sink current setting for LED1. See Figure 33 for LED sink current vs. code relationship.

Table 29. Register 0x16, LED2 Sink Current (LED2\_CURRENT)

Bit	Name	R/W	Description
7 to 6	Not used		
5 to 0	LED2_CURRENT	R/W	Sink current setting for LED2. See Figure 33 for the LED sink current vs. code relationship.

## APPLICATIONS INFORMATION

### CONVERTER TOPOLOGY

The ADP5501 backlight driver uses a dc-to-dc step-up (boost) converter to achieve the high voltage levels required to drive up to six white LEDs in series. Figure 43 shows the basic asynchronous boost converter topology.

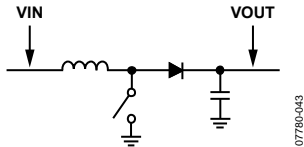

Figure 43. Basic Asynchronous Boost Converter Topology

Assuming an initial steady state condition where the switch has been open for a long time, the output voltage (VOUT) is equal to the input voltage (VIN), minus a diode drop.

If the switch is closed, the output voltage maintains its value as the diode blocks its path to ground. The inductor, however, has a voltage differential across its terminals. Current in an inductor cannot change instantaneously, so it increases linearly at a rate of

$$di/dt = VIN/L$$

where  $L$  is the inductance value in henrys.

If the switch is kept closed, the current increases until the inductor reaches its saturation limit, at which point the inductor becomes a dc path to ground. Therefore, the switch should be kept closed only long enough to build some transient energy in the inductor but not so long that the inductor becomes saturated.

When the switch is opened, the current that has built up in the inductor continues to flow (because the current in an inductor cannot change instantaneously), so the voltage at the top of the switch increases and forward biases the diode, allowing the inductor current to charge the capacitor and, therefore, increase the overall output voltage level. If the switch is opened and closed continuously, the output voltage continues to increase.

Figure 44 shows the boost configuration used in the ADP5501. A Schottky diode is used due to its fast turn-on time and low forward voltage drop. An input capacitor is added to reduce ripple voltage that is generated on the input supply due to charging/discharging of the inductor. An integrated power switch is used to control current levels in the inductor. A control loop consisting of a feedback signal, some safety limiting features, and a switch drive signal complete the boost converter topology.

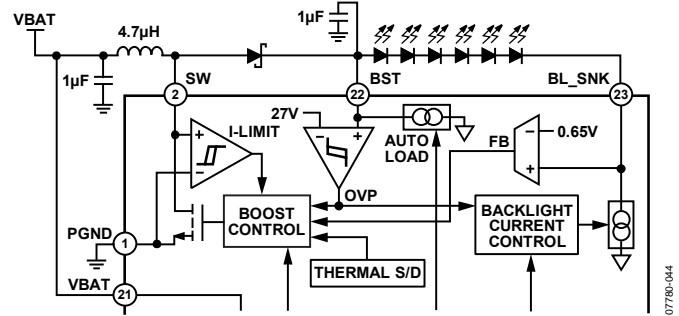

Figure 44. Boost Configuration

The ADP5501 uses a current-limiting, pulse frequency modulation (PFM) control scheme. For medium to large output currents, the converter operates in pseudo continuous conduction mode (CCM). It generates bursts of peak current limited pulses (600 mA typical) in the inductor, as shown in Figure 9.

For light output currents, the converter operates in pseudo discontinuous conduction mode (DCM). It generates bursts of small (200 mA, typical) and medium (400 mA, typical) current pulses in the inductor, as shown in Figure 11.

To maintain reasonable burst frequencies during very light load conditions, an automatic dummy load feature is available. When enabled, the 1 mA dummy load is activated if the backlight sink current code drops below 8 while in linear law mode or if the backlight sink current code drops below 32 while in square law mode.

### Safety Features

The ADP5501 uses an overvoltage protection (OVP) circuit that monitors the boosted voltage on the output capacitor. If the LED string becomes open (due to a broken LED), the control circuit continually commands the boost voltage to increase. If the boost level exceeds the maximum process rating for the ADP5501, damage to the device can occur. The ADP5501 boost converter has an OVP limit of 27 V (typical).

The ADP5501 also has a feature that ramps down the backlight code when an OVP condition is detected. This may be useful in conditions where LEDs with marginally high forward voltages are used in low ambient conditions. The feature can be enabled by setting the OVP\_EN bit in Register 0x02.

The ADP5501 also features a thermal shutdown circuit. When the die junction temperature reaches 150°C (typical), the boost converter shuts down. It remains shut down until the die temperature falls by 10°C (typical).

## Component Selection

The ADP5501 boost converter is designed for use with a 4.7  $\mu\text{H}$  inductor. Choose an inductor with a sufficient current rating to prevent it from going into saturation. The peak current limit of the ADP5501 is 750 mA (maximum), so choose an inductor with a greater saturation rating. To maximize efficiency, choose an inductor with a low series resistance (DCR).

The ADP5501 is an asynchronous boost and, as such, requires an external Schottky diode to conduct the inductor current to the output capacitor and LED string when the power switch is off. Ensure that the Schottky diode peak current rating is greater than the maximum inductor current. Choose a Schottky diode with an average current rating that is significantly larger than the maximum LED current. To prevent thermal runaway, derate the Schottky diode to ensure reliable operation at high junction temperatures. To maximize efficiency, select a Schottky diode with a low forward voltage. When the power switch is on, the Schottky diode blocks the dc path from the output capacitor to ground. Therefore, choose a Schottky diode with a reverse breakdown greater than the maximum boost voltage. A 40 V, 1 A Schottky diode is recommended.

The input capacitor carries the input ripple current, allowing the input power source to supply only the dc current. Use an input capacitor with sufficient ripple current rating to handle the inductor ripple. A 1  $\mu\text{F}$  X5R/X7R ceramic capacitor rated for 16 V dc bias is recommended for the input capacitance.

The output capacitor maintains the output voltage when the Schottky diode is not conducting. Due to the high levels of boost voltage required, a 1  $\mu\text{F}$  X5R/X7R ceramic capacitor rated for 50 V dc bias is recommended for output capacitance.

Note that dc bias characterization data is available from capacitor manufacturers and should be taken into account when selecting input and output capacitors.

## PCB LAYOUT

Good PCB layout is important to maximize efficiency and to minimize noise and electromagnetic interference (EMI). To minimize large current loops, place the input capacitor, inductor, Schottky diode, and output capacitor as close as possible to each other and to the ADP5501 using wide tracks (use shapes where possible).

For thermal relief, the exposed pad of the LFCSP package should be connected to ground (GND). PGND and GND should be connected to each other at the bottom of the output capacitor.

Figure 46 shows an example PCB layout with the main power components required for backlight driving

## EXAMPLE CIRCUIT

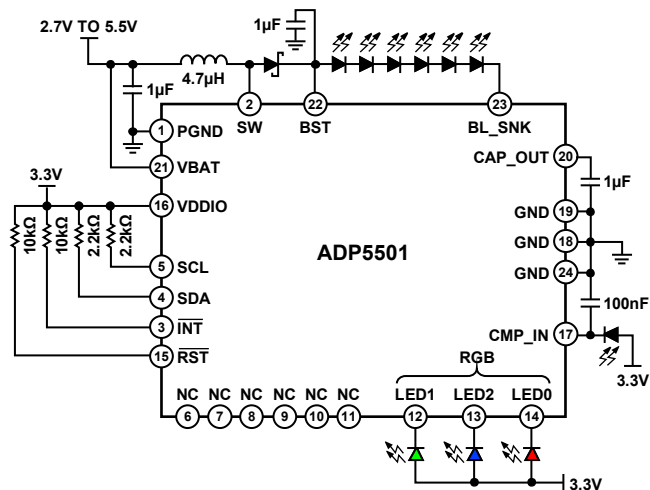

Figure 45. Typical Configuration Circuit

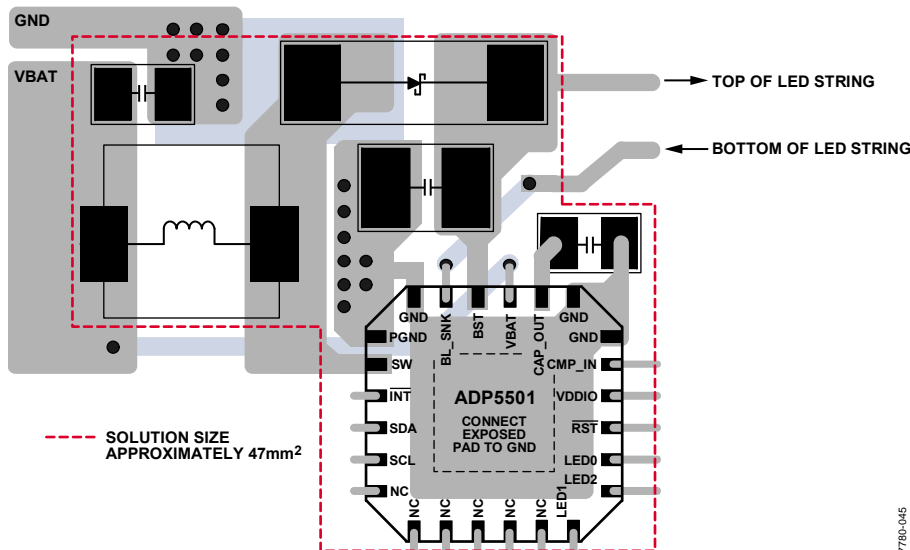
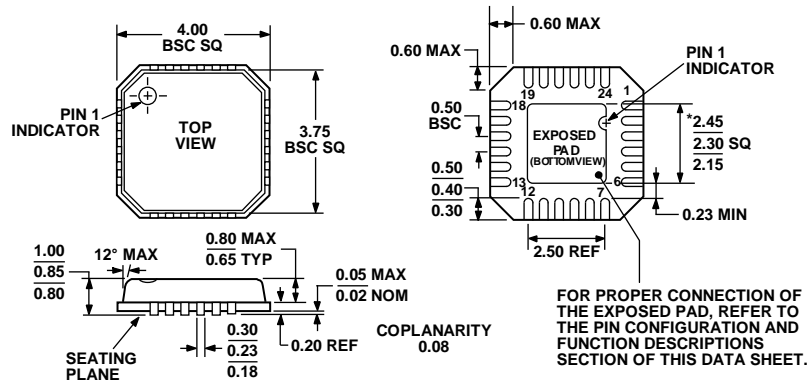

Figure 46. Example PCB Layout

## OUTLINE DIMENSIONS



\*COMPLIANT TO JEDEC STANDARDS MO-220-VGGD-2 EXCEPT FOR EXPOSED PAD DIMENSION

Figure 47. 24-Lead Lead Frame Chip Scale Package [LFCSP\_VQ]  
4 mm x 4 mm Body, Very Thin Quad (CP-24-2)  
Dimensions shown in millimeters

060808-A

## ORDERING GUIDE

Model	Temperature Range	Package Description	Package Option
ADP5501ACPZ-RL <sup>1</sup>	-40°C to +85°C	24-Lead Lead Frame Chip Scale Package [LFCSP_VQ]	CP-24-2

<sup>1</sup> Z = RoHS Compliant Part.